

# SEATTLE-TACOMA INTERNATIONAL AIRPORT

## JET FUEL STORAGE FACILITY IMPROVEMENTS

---

SEPTEMBER 2023

### SECTION 26 24 19

### MOTOR CONTROL CENTERS

#### TABLE OF CONTENTS

BILL OF MATERIALS

DRAWINGS

MANUALS AND CUT SHEETS

SOFTSTARTER

CIRCUIT BREAKER

TIMING RELAY

SELECTOR SWITCH

PUSHBUTTON

CONTACT BLOCKS

FUSE TERMINAL BLOCKS

FUSE



**OPTIMAL CONTROL SYSTEMS, INC.**

2324 Three Lakes Road SE

Albany, OR 97322

Phone: (541) 967-9323

Fax: (541) 967-9485

Project No. 0123-33JHK

THIS PAGE LEFT BLANK

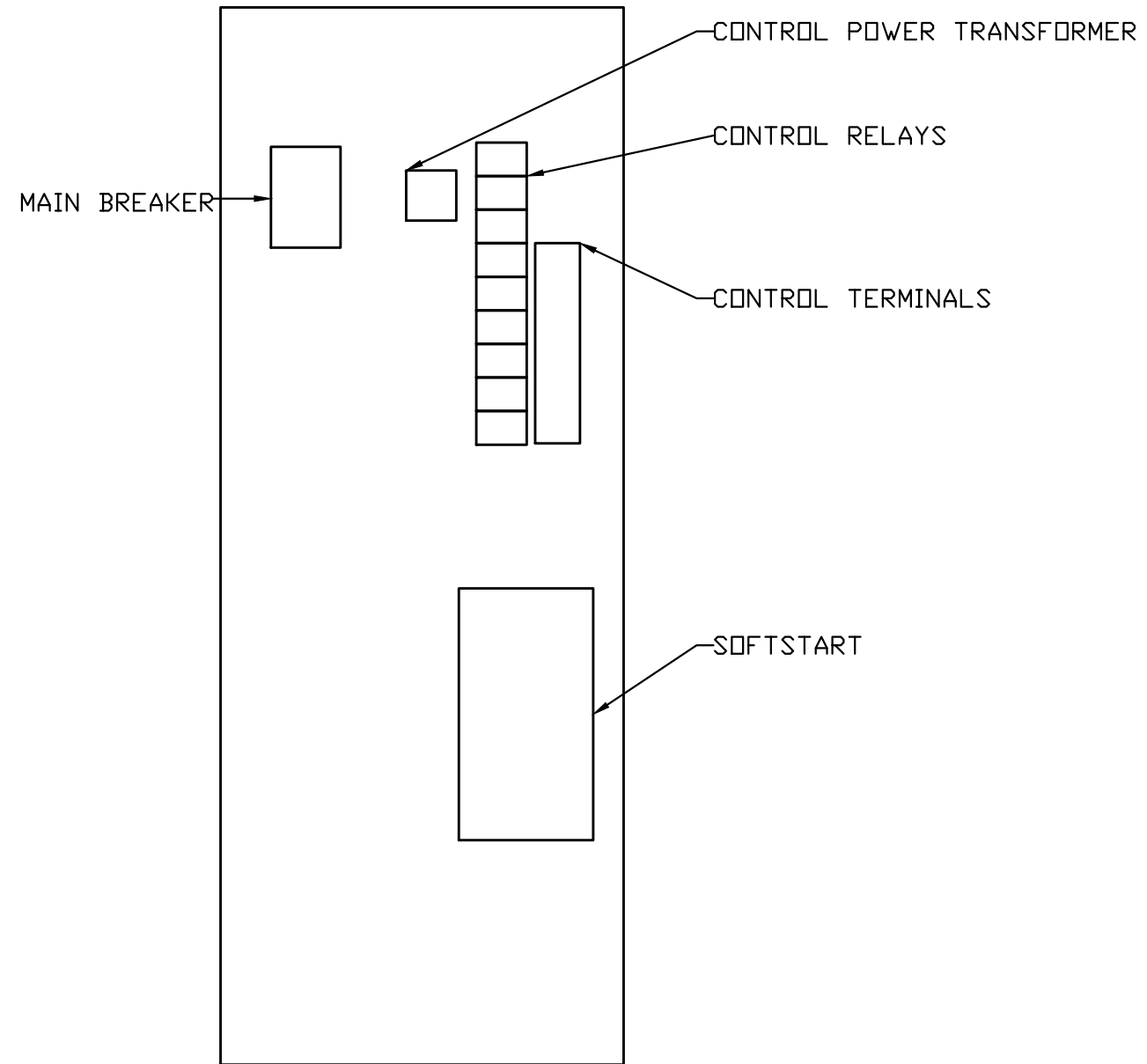
# Bill of Materials



**Project:** Jet Fuel Storage Facility Improvements  
**Specification Section(s):** Section 26 24 19 – Motor Control Centers  
**Date:** September 2023

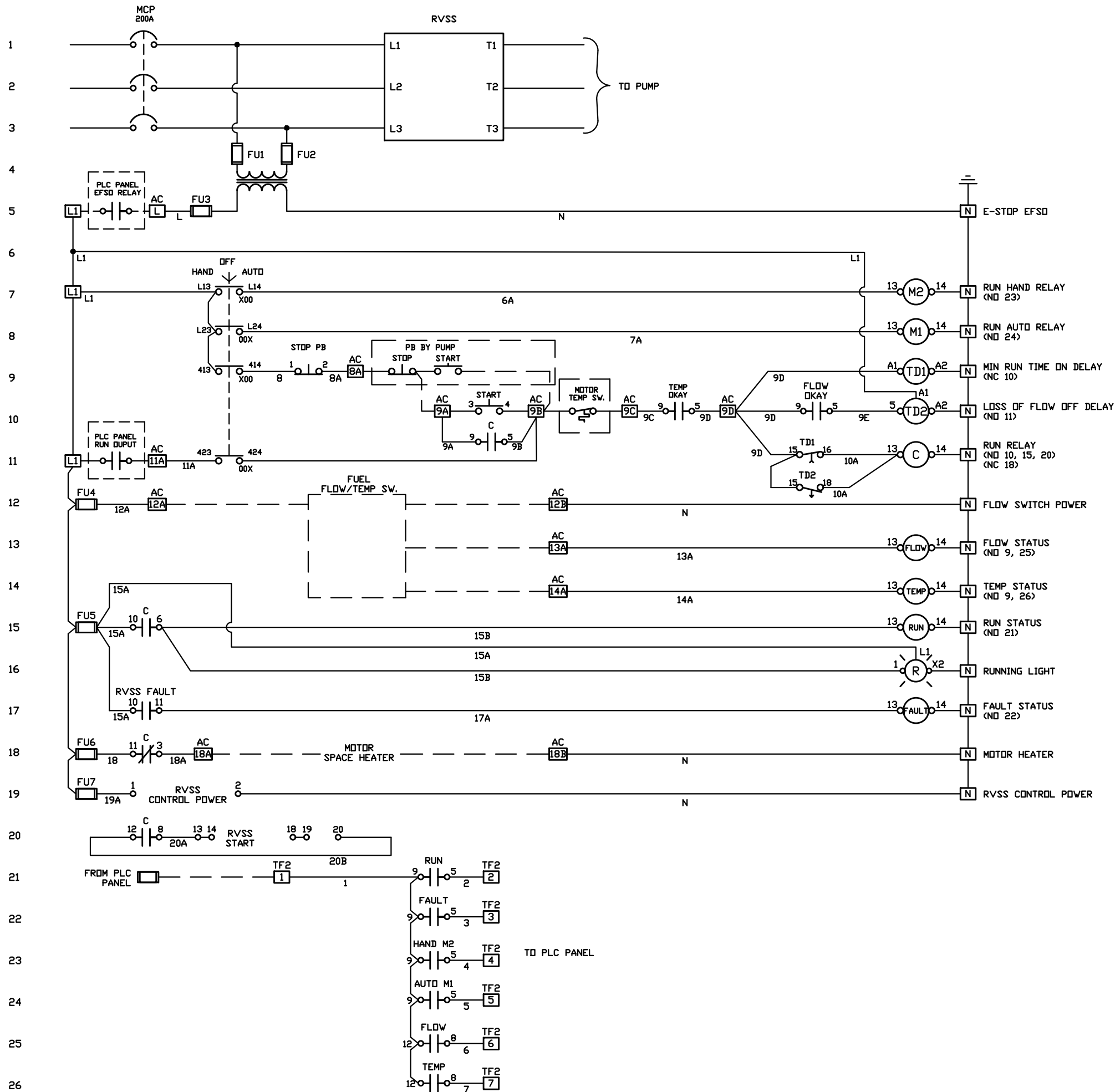
Item No.	Qty.	Description	Manufacturer	Manufacturer Part Number	Specification Section
001	2	170 A, R-Frame, Three-pole, Control Power 125-250 V Power, 208-600 V Operating, 47-63 Hz, Modbus RTU, NEMA 0, LCD Display	ABB	PSTX170-600-70	Section 26 24 19
002	2	Series C Molded Case Circuit Breaker, F-Frame, HFD, Fixed Thermal, Fixed Magnetic Trip Type, Three-Pole, 200 A, 600 Vac, 250 Vdc, 50/60 Hz	Eaton	HFD3200	Section 26 24 19
003	4	Timing Relay	Eaton	TMRD1UN	Section 26 24 19
004	2	3-Position Maintained Selector Switch	Eaton	10250T1323	Section 26 24 19
005	4	Black Flush Momentary Pushbutton	Eaton	10250T101	Section 26 24 19
006	4	120 Vac Fuse Terminal Block	ABB	1SNA115661R2100	Section 26 24 19
007	4	1 A, 5x20 mm Glass Fuse	Littelfuse	217001	Section 26 24 19
008	4	NO/NC Contact Block	Eaton	10250T1	Section 26 24 19
009	4	2NO Contact Block	Eaton	10250T2	Section 26 24 19
010					
011					
012					
013					
014					
015					
016					
017					
018					
019					
020					
021					
022					
023					
024					
025					
026					
027					
028					
029					
030					
031					
032					
033					
034					
035					

THIS PAGE LEFT BLANK



SOFTSTART RETROFIT

H				OPTIMAL CONTROL SYSTEMS			
G				2324 THREE LAKES RD / PO BOX 462			
F				ALBANY, OR 97321			
E				PHONE (541) 967-9323 FAX (541) 967-9485			
D				CLIENT JH Kelly			
C				TITLE SOFTSTART RETROFIT			
B				LAYOUT			
A	2023.7.28	Original Draft	HAD	DRAWN HAD	ISSUED	JOB NO. 0123-33JHK	
REV	DATE	DESCRIPTION	INIT	CHECKED	DATE 2023.7.28	DWG NO. 0123-33JHK-01	
REVISIONS				APPROVED	SCALE NONE	SHEET 1 OF 1	




UL NOTES:

480VAC: 4/0 THHN BLACK (TAPED BROWN,  
ORANGE & YELLOW  
120VAC: 14AWG RET, WHITE & MTW

FUSES: FU4, FU5, FU6, FU7 1A

TORQUE: TBS: 4.5-7 IN/LB  
MOTOR LEADS: 275-500 IN/LB  
BREAKER: 120-275 IN/LB

H				OPTIMAL CONTROL SYSTEMS		
G				2324 THREE LAKES RD / PO BOX 462		
F				ALBANY, OR 97321		
E				PHONE (541) 967-9323 FAX (541) 967-9485		
D				CLIENT JH Kelly		
C				TITLE SFTSTRT RETROFIT		
B	2023.09.19.	AS BUILT	KCED	SCHEMATIC		
A	2023.7.28	Original Draft	HAD	DRAWN HAD	ISSUED	JOB NO. 0123-33JHK
REV	DATE	DESCRIPTION	INIT	CHECKED	DATE	DWG NO. 0123-33JHK-02
				APPROVED	SCALE NONE	SHEET 1 OF 1

PRODUCT-DETAILS

# PSTX170-600-70

## PSTX170-600-70 Softstarter - 170 A - 208 ... 600 V AC



### General Information

Global Commercial Alias	PSTX170-600-70
Extended Product Type	PSTX170-600-70
Product ID	1SFA898111R7000
ABB Type Designation	PSTX170-600-70
EAN	7320500501436
Catalog Description	PSTX170-600-70 Softstarter - 170 A - 208 ... 600 V AC

### Long Description

The softstarter PSTX170-600-70 has a rated maximum operational current of 170 A with an operating voltage span from 208...600 V AC. The rated control voltage is between 100...250 V AC at 50/60 Hz. PSTX features a three-phase control soft start and stop through a voltage or a torque ramp. It has built-in bypass for easy installation and energy saving. A RUN, TOR and Event signal is available from relay outputs in NO (normally open state). The PSTX has functions such as current limit, kickstart, analog output, EOL, motor heating and pump cleaning. PSTX also features features jog, braking, stand-still brake, diagnostics, sequence start and emergency/fire pump mode as standard. To interact with PSTX, it has a detachable full graphic display with IP66 and 4x outdoor rating. There are four ways to communicate with PSTX. It can be done by hardwire inputs Start/Stop/Reset of fault, and by three programmable digital inputs. Another popular option is the built-in Fieldbus communication Modbus RTU and incl optional ANYBUS modules with every major protocol such as for example Profinet, Profibus, Modbus TCP, Ethernet IP and others. Another way to communicate with PSTX is to use an external adaptor and a Fieldbus plug. PSTX is the complete alternative for any motor starting application. It's suitable for medium to large-sized three-phase motors with nominal currents from 30...1250 A inline connection or 52...2160 A inside delta connection. Typical applications are, for example, pumps, fans, compressors, and conveyors.

### Ordering

Minimum Order Quantity	1 piece
Customs Tariff Number	85371091

## Popular Downloads

Data Sheet, Technical Information	1SFC132012C0201
Instructions and Manuals	1SFC132081M0201
CAD Dimensional Drawing	2CDC001079B0201
Wiring Diagram	N/A

## Dimensions

Product Net Width	199 mm
Product Net Height	377 mm
Product Net Depth / Length	283 mm
Product Net Weight	8.9 kg

## Technical

Rated Operational Voltage	208 ... 600 V AC
Rated Control Supply Voltage (U <sub>s</sub> )	100 ... 250 V AC
Rated Control Circuit Voltage (U <sub>c</sub> )	24 V DC
Rated Frequency (f)	50/60 Hz Main Circuit 50 / 60 Hz
Rated Operational Power - In-Line Connection (P <sub>e</sub> )	(230 V) 45 kW (400 V) 90 kW (500 V) 110 kW
Rated Operational Current - In-Line Connection (I <sub>e</sub> )	170 A
Rated Operational Power - Inside Delta Connection	at 230 V 90 kW at 400 V 160 kW at 500 V 200 kW
Rated Operational Current - Inside Delta Connection	300 A
Service Factor Percentage	100 %
Overload Protection	Built-in electronic overload protection
Integrated Electronic Overload	Yes
Adjustable Rated Motor Current I <sub>e</sub>	30 ... 100 %
Starting Capacity at Maximum Rated Current I <sub>e</sub>	4xI <sub>e</sub> for 10s
Ramp Time	1 ... 120 second [unit of time]
Initial Voltage During Start	10 ... 99 %
Step Down Voltage Special Ramp	100 ... 10 %
Current Limit Function	1.5 ... 7.5 xI <sub>e</sub>
Switch for Inside Delta Connection	Yes
Run Signal Relay	Yes



By-pass Signal Relay	Yes
Fault Signal Relay	Yes
Overload Signal Relay	Yes
Analog Outputs	0...10 V, 0...20 mA, 4...20 mA
Signal Indication Ready to Start/Standby ON (LED)	Green
Signal Indication Running R (LED)	Green
Signal Indication Protection (LED)	Yellow
Signal Indication Fault (LED)	Red
Communication	Modbus-RTU; Modbus-TCP; Ethernet-IP; EtherCAT; DeviceNet; CANopen; Profibus; Profinet; BACnet-IP; BACnet-MSTP
Degree of Protection	IP00
Terminal Type	Main Circuit: Bars
Connecting Capacity Main Circuit	Hole Diameter 8.5 mm
Connecting Capacity Control Circuit	Rigid 1 x 2.5 mm <sup>2</sup>
Connecting Capacity Supply Circuit	Rigid 1 x 2.5 mm <sup>2</sup>
Tightening Torque	Main Circuit 14 N·m
Product Main Type	PSTX170
Function	Auto phase sequence detection Automatic restart Current limit Current limit ramp Dual current limit Dynamic brake Electricity metering Electronic overload Time-to-cool Emergency mode Event log Full voltage start Jog with slow speed, forward and reverse Keypad password Kick start Limp mode with two-phase motor control if one set of thyristors is shorted Motor heating Pre-start function Pump cleaning Real time clock Sequence start Soft start with torque control Soft start with voltage ramp Soft stop with torque control Soft stop with voltage ramp Stand still brake Start reverse (external contactors) Thyristor runtime measurement Torque limit Voltage sags detection
Protection Function	Bypass open protection; Current imbalance protection; Current underload protection; Dual overload (separate overload for start and run); Earth fault protection / ground fault protection; Electronic overload protection, EOL; Extension IO failure protection; Fieldbus failure protection; HMI failure protection; Locked rotor protection; Max number of starts/hour; Over voltage protection; Phase reversal protection; Power factor underload protection; PT-100 connection; PTC connection; Too long current limit protection; Too long start time protection; Under voltage protection; User defined protection; Voltage imbalance protection
Warning Details	Current imbalance warning; Current underload warning; Electronic overload Time-to-trip; EOL warning; Faulty fan warning; Locked rotor warning; Motor runtime limit warning; Over voltage warning; Phase loss warning (for standby); Power factor underload warning; Short circuit warning (for Limp mode); THD(U) - Total Harmonic Distortion warning; Thyristor overload warning (SCR); Under voltage warning; Voltage imbalance warning

## Technical UL/CSA

Maximum Operating Voltage UL/CSA	Main Circuit 600 V
Tightening Torque UL/CSA	Main Circuit 123.9

## Environmental

Ambient Air Temperature	Operation -25 ... +60 °C Storage -40 ... +70 °C
Degree of Protection	IP00
RoHS Status	Following EU Directive 2002/95/EC August 18, 2005 and amendment

## Certificates and Declarations

CQC Certificate	CN: CQC2014010304744407 / SE: CQC2014010304724379
Declaration of Conformity - CCC	CN: 2020980304001092 / SE: 2020980304001485
Declaration of Conformity - CE	2CMT005209

## Container Information

Package Level 1 Width	263 mm
Package Level 1 Depth / Length	323 mm
Package Level 1 Height	454 mm
Package Level 1 Gross Weight	10.4 kg
Package Level 1 EAN	7320500501436
Package Level 1 Units	box 1 piece

## Classifications

Object Classification Code	Q
ETIM 7	EC000640 - Soft starter
ETIM 8	EC000640 - Soft starter
ETIM 9	EC000640 - Soft starter
eClass	V11.0 : 27370907
UNSPSC	39121521
IDEA Granular Category Code (IGCC)	4740 >> Soft starter

## Accessories

Identifier	Description	Type	Quantity	Unit Of Measure
1SDA066917R1	KIT FC Cu XT4 3pcs	KIT FC Cu XT4 3pcs	1	piece
1SFN074709R1000	LZ185-2C/120 Cable Clamp Connector	LZ185-2C/120	1	piece
1SDA055016R1	KIT FC Cu 1x240mm2 T5 400 3pcs	KIT FC Cu 1x240mm2 T5 400 3pcs	1	piece
1SCA022194R0890	OZXB4/1 AL-CU TERMINAL 1PC	OZXB4/1	1	piece

1SDA013922R1	KIT FC CuAl 2x240mm2 T6 630-S6 630 6pcs	KIT FC CuAl 2x240mm2 T6 630-S6 630 6pcs	1	piece
1SDA013956R1	KIT FC CuAl 3x185mm2 T6 800-S6 800 6pcs	KIT FC CuAl 3x185mm2 T6 800-S6 800 6pcs	1	piece
1SDA054988R1	KIT FC CuAl 1x185mm2 T4 3pcs	KIT FC CuAl 1x185mm2 T4 3pcs	1	piece
1SDA055020R1	KIT FC CuAl 1x240mm2 T5 400 3pcs	KIT FC CuAl 1x240mm2 T5 400 3pcs	1	piece
1SDA023380R1	KIT FC CuAl 2x240mm2 T6 630-S6 630 3pcs	KIT FC CuAl 2x240mm2 T6 630-S6 630 3pcs	1	piece
1SFN074810R1000	LX205 Terminal Extension	LX205	1	piece
1SFN075410R1000	LX370 Terminal Extension	LX370	1	piece
1SFN075710R1000	LX460 Terminal Extension	LX460	1	piece
1SFN074307R1000	LW110 Terminal Enlargement	LW110	1	piece
1SFN074807R1000	LW205 Terminal Enlargement	LW205	1	piece
1SFN075407R1000	LW370 Terminal Extension	LW370	1	piece
1SFN075707R1000	LW460 Terminal Enlargement	LW460	1	piece
1SFN076107R1000	LW750 Terminal Enlargement	LW750	1	piece
1SFN124801R1000	LT205-30C Terminal Shroud	LT205-30C	1	piece
1SFN124803R1000	LT205-30L Terminal Shroud	LT205-30L	1	piece
1SFN125401R1000	LT370-30C Terminal Shroud	LT370-30C	1	piece
1SFN125403R1000	LT370-30L Terminal Shroud	LT370-30L	1	piece
1SFN125406R1000	LT370-30D Terminal Shroud	LT370-30D	1	piece
1SFN125701R1000	LT460-AC Terminal shroud	LT460-AC	1	piece
1SFN125703R1000	LT460-AL Terminal shroud	LT460-AL	1	piece
1SFN126101R1000	LT750-AC Terminal shroud	LT750-AC	1	piece
1SFN126103R1000	LT750-AL Terminal shroud	LT750-AL	1	piece
1SFA899314R1001	PSCA-1 USB cable	PSCA-1	1	piece
1SFA899300R1001	AB-PROFIBUS-1 Communication Module	AB-PROFIBUS -1	1	piece
1SFA899300R1002	AB-DEVICENET-1 Communication Module	AB- DEVICENET-1	1	piece
1SFA899300R1003	AB-MODBUS-RTU-1 Communication Module	AB-MODBUS- RTU-1	1	piece
1SFA899300R1006	AB-ETHERNET-IP-2 Communication Module	AB- ETHERNET-IP -2	1	piece
1SFA899300R1008	AB-MODBUS-TCP-2 Communication Module	AB-MODBUS- TCP-2	1	piece
1SFA899300R1010	AB-PROFINET-IO-2 Communication Module	AB-PROFINET -IO-2	1	piece
1SFA899300R1011	AB-BACNET-MSTP-1 Communication Module	AB-BACNET- MSTP-1	1	piece
1SFA899300R1012	AB-ETHERCAT-IP-2 Communication Module	AB- ETHERCAT-IP -2	1	piece
1SAJ611000R0101	DX111-FBP.0 IO-Module for UMC100 DI 24 VDC, supply 24VDC	DX111-FBP.0	1	piece
1SAJ622000R0101	DX122-FBP.0 IO-Module for UMC100 DI 110/230VAC, supply 24VDC	DX122-FBP.0	1	piece
1SFA896312R1002	PS-FBPA Fieldbus plug kit	PS-FBPA	1	piece

---

## Categories

---

Drives → Softstarters → Softstarters → PSTX Softstarters → PSTX170

Low Voltage Products and Systems → Control Products → Softstarters → Softstarters → PSTX Softstarters → PSTX170



# PSTX softstarter

## The advanced range

**13** Certificates  
**11** Built-in protections  
**23** Application features



PSTX is our most advanced softstarter with full control and motor protection built-in. PSTX is the most complete alternative for any motor starting application.

Featuring built-in modbus and anybus modules that support all major communication protocols.

01 PSTX advanced range softstarter

### Complete motor protection

The PSTX offers complete motor protection in only one unit and is able to handle both load and network irregularities. PT-100, earth fault protection and over/under voltage protection along with many other functions keep your motor safer than ever. PSTX also offers three types of current limit: standard, dual and ramp. This gives you full control of your motor during start. It also allows you to use your motor in weaker networks.

### Built-in bypass saves time and energy

When reaching full speed, the PSTX will activate its bypass. This saves energy while reducing the softstarters heat generation. On the PSTX, the bypass is built in and verified by ABB, saving you time during installation and space in your panel.

### Complete control of pumps

Time to use your processes to their full potential. The PSTX features many application enhancing features, including torque control: the most efficient way to start and stop pumps. The pump cleaning feature can reverse pump flow and clean out pipes, securing uptime of your pump system.

### HMI

A user-friendly and clear display saves you time and resources during both setup and operation. The detachable keypad is standard on all PSTX softstarters with IP66 and 4x outdoor for tough environments.

### Jog with slow speed forward & reverse

The slow speed forward and backward jog feature will make you more flexible when operating e.g. conveyor belts and cranes.

### Coated PCB

Coated circuit boards protecting from dust, moist and corrosive atmosphere. PSTX coating type DOW CORNING 1-2620 LOW VOC.

### Heavy duty

Designed to handle heavy applications such as centrifugal fan, mill and mixers.

### Torque control

The torque control function the absolutely best possible stop of pumps without water hammering and pressure surges.

Technical data		PSTX30... 1250
Rated insulation voltage U <sub>i</sub>	690V	
Rated operational voltage U <sub>e</sub>	208...600 V, 208...690V +10% / -15%, 50/60Hz ±10%	
Rated control supply voltage U <sub>s</sub>	100...250 V +10%/-15%, 50/60Hz ±10%	
Rated control circuit voltage U <sub>c</sub>	Internal or external 24 V DC	
Starting capacity at I <sub>e</sub>	4 x I <sub>e</sub> for 10 sec	
Number of starts per hour	10 for PSTX30 ... PSTX370 <sup>1)</sup> 6 for PSTX470 ... PSTX1250 <sup>1)</sup>	
Overload capability	Overload class 10	
Maximum altitude	4000 m (13123 ft) <sup>3)</sup>	

Ambient temperature	
During operation	-25...+60 °C, (-13...+140 F) <sup>2)</sup>
During storage	-40...+70 °C, (-40...+158 F)

Degree of protection	
Main circuit	-
Supply and control circuit	IP20

Main circuit	
Built-in bypass contactor	Yes
Cooling system - Fan cooled	Yes (thermostat controlled)

HMI for settings (Human Machine Interface)	
Display	LCD type, graphical
Languages	Arabic, Chinese, Czech, Dutch, English, Finnish, French, German, Greek, Indonesian, Italian, Polish, Portuguese, Russian, Spanish, Swedish and Turkish
Keypad	2 selection keys, 4 navigation keys, start key, stop key, info key and remote/local key

Signal relays	
Number of programmable signal relays	3 (each relay can be programmed to None, Run, Top of ramp, Event group 0-6, Sequence 1-3 Run, Sequence 1-3 Top of ramp or Run reverse)
K4	Default as Run signal
K5	Default as Top of Ramp (Bypass) signal
K6	Default as Event group 0 (Faults)

Rated operational voltage, U <sub>e</sub>	250 V AC/24 V DC
Rated thermal current I <sub>th</sub>	5 A
Rated operational current I <sub>e</sub> at AC-15 (U <sub>e</sub> =250 V)	1.5 A

Analog output	
Output signal reference	0...10 V, 0...10 mA, 0...20 mA, 4...20 mA
Type of output signal	Motor current (A), Main voltage (V), Active power (kW), Active power (HP), Reactive power (kVAr), Apparant power (kVArh), Active energy (kWh), Reactive energy (kVArh), cos phi, Motor temperature (%), Thyristor temperature (%), Motor voltage (%), Main frequency (Hz), PT100 temperature (centigrade), PTC resistance (Ohm)

Directives and standards	
No. 2006/95/EC	Low voltage equipment
No. 2004/108/EC	Electromagnetic compatibility
EN 60947-1	Low-voltage switchgear and controlgear - Part 1: General rules
EN 60947-4-2	AC semiconductor motor controllers and starters
UL 508	Industrial Control Equipment
CSA C22.2 No 14	Industrial Control Equipment

<sup>1)</sup> Valid for normal start (class 10) for 50% on time and 50% off time. If other data is required, contact your local ABB office.  
<sup>2)</sup> Above 40 °C (104 F) up to max. 60 °C (140 F) reduce the rated current with 0,8% per °C (0,44% per F).  
<sup>3)</sup> When used at high altitudes, above 1000 meters (3281 ft) up to 4000 meters (13123 ft), de-rate the rated current using the following formula.  $[\% \text{ of } I_e = 100 - \frac{x-1000}{150}] \times x = \text{actual altitude of the softstarter in meter, } [\% \text{ of } I_e = 100 - \frac{x-3280}{497}] \times x = \text{actual altitude of the softstarter in feet. For de-rating of voltage, contact your local ABB office.}$

Control circuit	
Number of inputs	2 (start, stop)
Number of additional programmable inputs	3 (each input can be programmed to: None, Reset, Enable, Slow speed forward (Jog), Slow speed reverse (Jog), Motor heating, Stand still brake, Start reverse, User defined protection, Emergency mode (active high), Emergency mode (active low), Fieldbus disable control, Start 1, Start 2, Start 3, Switch to remote control or Cancel brake)

Signalling indication LED	
Ready	Green
Run	Green
Fault	Red
Protection	Yellow

External keypad	
Detachable keypad	Yes
Display	LCD type, graphical

Ambient temperature	
During operation	-25...+60 °C, (-13...+140 F)
During storage	-40...+70 °C, (-40...+158 F)
Degree of protection	IP66 (Type 1, 4X, 12)

Start and stop functions	
Soft start with voltage ramp	Linear voltage ramp, suitable for most applications
Soft stop with voltage ramp	Used to prolong the stop sequence
Soft start with torque control	Linear torque ramp, the best way to start pumps
Soft stop with torque control	Commonly used to reduce water hammering in pumps
Kick start	More power in the start for heavy duty applications.
Full voltage start	0.5 second start ramp for applications with need of high starting torque
Sequence start	Start multiple motors with one softstarter
Current limit	Limits the current below a specified value
Dual current limit	Consist of a low level, a high level and a time between them
Current limit ramp	A linear increase of the current from the low to the high level
Torque limit	Limit the torque to between 20-200%
Pre-start function	Use Motor heating, Stand still brake or Jog automatically prior to start ramp
Jog with slow speed, forward and reverse	Run the motor in three different speeds, both forward and reverse
Start reverse (external contactors)	Internal logic that allows control of external contactors for reverse start
Dynamic brake	Provides a braking force to decrease stop time

Product compliance	
CE, cULus, CCC, EAC, ANCE, C-tick, KC, ABS, DNV GL, Lloyd's Register, CCS, PRS, Class NK	



PSTX Dimensions and weight					
Frame size	H (mm)	W (mm)	D <sup>1)</sup> (mm)	(kg)	(lb)
PSTX30...105	314	150	197.5	6.10	13.45
PSTX142...170	377	199	283.3	9.60	21.16
PSTX210...370	470	258	279.1	12.70	27.99
PSTX470...570	493	361	282.15	25.00	55.12
PSTX720...840	493	435	366.5	46.20	101.85
PSTX1050	515	435	366.5	64.20	141.64
PSTX1250	565	435	366.5	64.70	142.64

<sup>1)</sup> Note: Include HMI

<b>Fieldbus connection</b>	
Built-in Modbus RTU	Yes, with RS485 interface on terminals 23 and 24
Connection for Anybus	Yes, including most common protocols, see catalog for details
Connection for ABB Fieldbus plug	Yes, compatible with a special adapter, see catalog for details
<b>Protections</b>	
Electronic overload protection, EOL	User defined, class 10A, 10, 20, 30
Dual overload (separate overload for start and run)	Possible to set separate overloads for start and full speed
PTC connection	User defined temperature control with external PTC sensor
PT-100 connection	User defined temperature control with external PT-100 sensor
Locked rotor protection	Prevents start if motor is stuck, e.g. stuck pumps and conveyors
Current underload protection	Stops the process if the load is too light, e.g. a pump running dry
Current imbalance protection	User defined, checks current imbalance between the phases
Power factor underload protection	User defined, trip if power factor is out of range
Under voltage protection	User defined, prevents the motor from stalling in weak networks
Over voltage protection	User defined, prevents the motor from damage at high voltage levels
Voltage imbalance protection	User defined, checks voltage imbalance between the phases
Earth fault protection / ground fault protection	User defined, 0.1-1.0 sec, stops the process if earth fault is detected
Phase reversal protection	Prevents start if phases are connected in the wrong order
Bypass open protection	Trips if the bypass is open when it should be closed
User defined protection	Programmable input, can be used with external protection device
Too long current limit protection	User defined, trips when the current has been at the current limit for too long time
HMI failure protection	Indicates communication failure between softstarter and HMI
Fieldbus failure protection	Indicates communication failure between softstarter and PLC
Extension IO failure protection	Indicates communication failure between softstarter and IO module
Max number of starts/hour	Prevents start if the thyristors gets too warm (thus used over specification)
Too long start time protection	User defined, trips when the starting time exceeds a set value
<b>External faults detection</b>	
Phase loss	Yes
High current	Yes
Low control supply voltage	Yes
Faulty usage	Yes, e.g. using limp mode inside-delta
Faulty connection	Yes
Bad network quality	Yes

For all functions and features see installation and commissioning manual, 1SFC132081M0201 available on [new.abb.com/drives/softstarter](https://new.abb.com/drives/softstarter)

For more information, please contact your local ABB representative or visit <https://new.abb.com/drives/softstarters>

We reserve the right to make technical changes or modify the contents of this document without prior notice. With regard to purchase orders, the agreed particulars shall prevail. ABB AG does not accept any responsibility whatsoever for potential errors or possible lack of information in this document.

<b>Warnings</b>	
Current underload warning	User defined on/off
Current imbalance warning	User defined on/off
Voltage imbalance warning	User defined on/off
Thyristor overload warning (SCR)	User defined on/off
Electronic overload Time-to-trip	User defined on/off
Short circuit warning (for Limp mode)	User defined on/off, for Limp mode
Over voltage warning	User defined on/off
Under voltage warning	User defined on/off
Power factor underload warning	User defined on/off
Locked rotor warning	User defined on/off
Faulty fan warning	User defined on/off
THD(U) - Total Harmonic Distortion warning	User defined on/off
Motor runtime limit warning	User defined on/off
Phase loss warning (for stand by)	User defined on/off, for stand by
EOL warning	User defined on/off
<b>Internal faults detection</b>	
Thyristor overload	Yes
Short circuit	Yes
Open circuit thyristor or gate	Yes
Heat sink over temperature	Yes
Shunt fault	Yes
<b>PTC input</b>	
Switch off resistance	2825 ohm ± 20%
Switch on resistance	1200 ohm ± 20%
<b>Other functions</b>	
Real time clock	Can maintain time when the softstarter isn't powered up, 48 h back-up
Event log	Log of events such as trips, parameters changed and operation
Emergency mode	To keep the softstarter running regardless of trip or failure. Activated via DI
Automatic restart	In case of trip and stopped motor, the softstarter can restart itself
Keypad password	Lock the keypad to inhibit unauthorized motor control
Pump cleaning	Can reverse pump flow and clean out pipes
Electronic overload Time-to-cool	Time until the motor is ready to be restarted after an EOL trip
Thyristor runtime measurement	Measures most electrical variables, e.g. voltage, current and power
Auto phase sequence detection	Detection of the phase sequence
Electricity metering	Measures most electrical variables, e.g. voltage, current and power
Motor heating	DC injection in all windings to heat up the motor. Useful in cold or humid environment
Stand still brake	Prevents the motor from moving, useful to keep fans from reversing
Voltage sags detection	User defined
Limp mode with two-phase motor control if one set of thyristors is shorted	Can keep process running until planned maintenance

We reserve all rights in this document and in the subject matter and illustrations contained therein. Any reproduction, disclosure to third parties or utilization of its contents – in whole or in parts – is forbidden without prior written consent of ABB AG. Copyright© 2019 ABB All rights reserved

THIS PAGE LEFT BLANK



SOFTSTARTERS TYPE PSTX

# Short circuit rating

## UL short circuit rating



PREPARED		STATUS	SECURITY LEVEL		
2021-12-21	D Wikström	Approved	Public		
APPROVED		DOCUMENT KIND			
2021-12-21	J Estelli	Technical document			
OWNING ORGANIZATION		DOCUMENT ID.	REV.	LANG.	PAGE
ABB AB Electrification Sweden AB		1SFC132423M0201	B	en	1/9
© Copyright 2019 ABB. All rights reserved.					

# Contents

- 1. Fuses .....3
- 2. Breakers, Standard fault current PSTX30...370 ..... 4
- 3. Breakers, Standard fault current PSTX470...840 .....5
- 4. Breakers, High fault current PSTX30...105 ..... 6
- 5. Breakers, High fault current PSTX142...170 ..... 7
- 6. Breakers, High fault current PSTX210...370 ..... 8
- 7. Breakers, High fault current PSTX470...840 .....9

STATUS	SECURITY LEVEL	DOCUMENT ID.	REV.	LANG.	PAGE
Approved	Public	1SFC132423M0201	B	en	2/9

# 1. Fuses

Softstarter type	Standard Fault Current						High Fault Current					
	208V	220-240V	440-480V	550-600V	Fuse Max (A)	Fuse type	208 V	220-240 V	440-480 V	600 V	Fuse Max (A)	Fuse type
PSTX30...60	5kA				225	RK5	100kA				225	Class J
PSTX72	5kA		5kA	10kA								
PSTX85...105			10kA									
PSTX142	5kA		10kA		350	RK5	100kA				350	Class J
PSTX170	10kA											
PSTX210	10kA				600	RK5	100kA				600	Class J
PSTX250	10kA		18kA									
PSTX300	10kA		18kA									
PSTX370												
PSTX470	10kA		18kA	30kA	1200	L	100kA				1200	Class L
PSTX570	10kA		30kA									
PSTX720	18kA		30kA	42kA	1600	L	100kA				1600	Class L
PSTX840	18kA		42kA									
PSTX1050	18kA	30kA	42kA	85kA	2500	L	100kA				2500	Class L
PSTX1250	18kA	30kA	85kA									

## 2. Breakers, Standard fault current PSTX30...370

Softstarter type	208V	220-240V	440-480V	550-600V	MCCB Max (A)	MCCB type [ABB SACE]
PSTX30...60	5kA				125	XT2N/XT2S/XT2H XT2L/XT2V/XT2X
PSTX72	5kA			10kA		
PSTX85...105	5kA	10kA				
PSTX30...60	5kA				250	T4N/T4S/T4H/T4L/T4V XT4N/XT4S/XT4H/XT4L XT4V/XT4X
PSTX72	5kA			10kA		
PSTX85...105	5kA	10kA				
PSTX142	5kA		10kA		250	T4N/T4S/T4H/T4L/T4V XT4N/XT4S/XT4H/XT4L XT4V/XT4X
PSTX170	5kA	10kA				
PSTX142	5kA		10kA			
PSTX170	5kA	10kA		300	T5N400/T5S400 T5H400/T5L400	
PSTX142	5kA		10kA			
PSTX170	5kA	10kA				
PSTX142	5kA		10kA		400	XT5N/XT5S/XT5H XT5L/XT5V
PSTX170	5kA	10kA				
PSTX210	10kA				250	XT4N/XT4S/XT4H/XT4L XT4V/XT4X
PSTX250	10kA			18kA		
PSTX300	10kA		18kA			
PSTX370	10kA		18kA			
PSTX210	10kA				400	T5N/T5S/T5H/T5L/T5V XT5N/XT5S/XT5H XT5L/XT5V
PSTX250	10kA			18kA		
PSTX300	10kA		18kA			
PSTX370	10kA		18kA			
PSTX210	10kA				600	T5N/T5S/T5H/T5L/T5V XT5N/XT5S/XT5H XT5L/XT5V
PSTX250	10kA			18kA		
PSTX300	10kA		18kA			
PSTX370	10kA		18kA			
PSTX210	10kA				600	T6N800/T6S800/T6H800 T6L800
PSTX250	10kA			18kA		
PSTX300	10kA		18kA			
PSTX370	10kA		18kA			
PSTX210	10kA				800	XT6N/XT6S/XT6H
PSTX250	10kA			18kA		
PSTX300	10kA		18kA			
PSTX370	10kA		18kA			

### 3. Breakers, Standard fault current PSTX470...840

Softstarter type	208V	220-240V	440-480V	550-600V	MCCB Max (A)	MCCB type [ABB SACE]
PSTX470	10kA		18kA	30kA	800	T6N/T6S/T6H/T6L XT6N/XT6S/XT6H
PSTX570	10kA		30kA			
PSTX470	10kA		18kA	30kA	1200	T7S/T7H/T7L XT7S/XT7H/XT7L
PSTX570	10kA		30kA			
PSTX470	10kA		18kA	30kA	3200	E4S-A/E4H-A/E4V-A
PSTX570	10kA		30kA			
PSTX720...840	18kA		-		800	T6N/T6S/T6H
PSTX720	18kA		30kA	42kA		T6L
PSTX840	18kA		42kA			
PSTX720	18kA		30kA	-	800	XT6N
PSTX840	18kA		-			
PSTX720	18kA		30kA	-	800	XT6S
PSTX840	18kA		42kA	-		XT6H
PSTX720	18kA		30kA	-	1200	T7S
PSTX840	18kA		42kA	-		XT7S
PSTX720	18kA		30kA	42kA	1200	T7H/T7L/XT7H/XT7L
PSTX840	18kA		42kA			
PSTX720	18kA		30kA	42kA	3000	T8V
PSTX840	18kA		42kA			

## 4. Breakers, High fault current PSTX30...105

Softstarter type	208V	220-240V	440-480V	550 - 600V	MCCB Max (A)	MCCB type [ABB SACE]
PSTX30...105	65kA	25kA	18kA	125	125	XT2N
	100kA	35kA	22kA	125	125	XT2S
	100kA	65kA	25kA	125	125	XT2H
	100kA	100kA	35kA	125	125	XT2L
	100kA	100kA	42kA	125	125	XT2V
	100kA	100kA	42kA	125	125	XT2X
	65kA	25kA	18kA	250	250	T4N
	100kA	35kA	25kA	250	250	T4S
	100kA	65kA	35kA	250	250	T4H
	100kA	100kA	65kA	250	250	T4L
	100kA	100kA	100kA	250	250	T4V
	65kA	25kA	18kA	250	250	XT4N
	100kA	35kA	22kA	250	250	XT4S
	100kA	65kA	25kA	250	250	XT4H
	100kA	100kA	50kA	250	250	XT4L
	100kA	100kA	65kA	250	250	XT4V
	100kA	100kA	100kA	250	250	XT4X
	100kA	100kA	100kA	150	150	XT4X

## 5. Breakers, High fault current PSTX142...170

Softstarter type	208V	220-240V	440-480V	550 - 600V	MCCB Max (A)	MCCB type [ABB SACE]
PSTX142...170		65kA	25kA	18kA	250	T4N
		100kA	35kA	25kA	250	T4S
		100kA	65kA	35kA	250	T4H
		100kA	100kA	65kA	250	T4L
		100kA	100kA	100kA	250	T4V
		65kA	25kA	18kA	250	XT4N
		100kA	35kA	22kA	250	XT4S
		100kA	65kA	25kA	250	XT4H
		100kA	100kA	50kA	250	XT4L
		100kA	100kA	65kA	250	XT4V
PSTX142		25kA	25kA	18kA	300	T5N400
		25kA	25kA	25kA	300	T5S400
		25kA	25kA	25kA	300	T5H400
		25kA	25kA	25kA	300	T5L400
		25kA	25kA	18kA	400	XT5N
		25kA	25kA	25kA	400	XT5S
		25kA	25kA	18kA	600	XT5N
PSTX170		65kA	25kA	18kA	300	T5N400
		65kA	35kA	25kA	300	T5S400
		65kA	65kA	35kA	300	T5H400
		65kA	65kA	65kA	300	T5L400
		65kA	35kA	18kA	400	XT5N
		65kA	50kA	25kA	400	XT5S
		65kA	65kA	35kA	400	XT5H
		65kA	65kA	65kA	400	XT5L
		100kA	100kA	100kA	400	XT5V
		65kA	35kA	18kA	600	XT5N
		100kA	50kA	25kA	600	XT5S
		100kA	65kA	35kA	600	XT5H
		100kA	100kA	65kA	600	XT5L
	100kA	100kA	100kA	600	XT5V	
	100kA	100kA	100kA	600	XT5X	

## 6. Breakers, High fault current PSTX210...370

Softstarter type	208V	220-240V	440-480V	550 - 600V	MCCB Max (A)	MCCB type [ABB SACE]
PSTX210...370	65kA		25kA	18kA	250	XT4N
	100kA		35kA	22kA	250	XT4S
	100kA		65kA	25kA	250	XT4H
	100kA		100kA	50kA	250	XT4L
	100kA		100kA	65kA	250	XT4V
	100kA		100kA	65kA	250	XT4X
	65kA		25kA	18kA	400	T5N
	100kA		35kA	25kA	400	T5S
	100kA		65kA	35kA	400	T5H
	100kA		100kA	65kA	400	T5L
	100kA		100kA	100kA	400	T5V
	65kA		25kA	18kA	600	T5N
	100kA		35kA	25kA	600	T5S
	100kA		65kA	35kA	600	T5H
	100kA		100kA	65kA	600	T5L
	100kA		100kA	100kA	600	T5V
	65kA		35kA	20kA	600	T6N800
	65kA		50kA	25kA	600	T6S800
	100kA		65kA	35kA	600	T6H800
	94.4kA		94.4kA	-	600	T6L800
PSTX210...370	65kA		25kA	18kA	400	XT5N
	100kA		35kA	25kA	400	XT5S
	100kA		65kA	35kA	400	XT5H
	100kA		100kA	65kA	400	XT5L
	100kA		100kA	100kA	400	XT5V
	100kA		100kA	100kA	400	XT5X
	65kA		25kA	18kA	600	XT5N
	100kA		35kA	25kA	600	XT5S
	100kA		65kA	35kA	600	XT5H
	100kA		100kA	65kA	600	XT5L
	100kA		100kA	100kA	600	XT5V
	100kA		100kA	100kA	600	XT5X
	65kA		35kA	20kA	800	XT6N
	100kA		50kA	25kA	800	XT6S
	100kA		65kA	35kA	800	XT6H



## 7. Breakers, High fault current PSTX470...840

Softstarter type	208V	220-240V	440-480V	550 - 600V	MCCB Max (A)	MCCB type [ABB SACE]
PSTX470...570	65kA		35kA	-	800	T6N
	65kA		50kA	-	800	T6S
	65kA		65kA	35kA	800	T6H
	65kA		65kA	42kA	800	T6L
	65kA		35kA	-	800	XT6N
	65kA		50kA	-	800	XT6S
	65kA		65kA	35kA	800	XT6H
	65kA		-	-	1200	T7S
	65kA		50kA	50kA	1200	T7H
	65kA		65kA	65kA	1200	T7L
	65kA		-	-	1200	XT7S
	65kA		50kA	50kA	1200	XT7H
	65kA		65kA	65kA	1200	XT7L
	PSTX720...840	65kA		35kA	-	800
65kA			50kA	-	800	T6S
65kA			65kA	-	800	T6H
65kA			65kA	-	800	T6L
65kA			35kA	-	800	XT6N
65kA			50kA	-	800	XT6S
65kA			65kA	-	800	XT6H
65kA			-	-	1200	T7S
65kA			50kA	50kA	1200	T7H
65kA			65kA	65kA	1200	T7L
65kA			-	-	1200	XT7S
65kA			50kA	50kA	1200	XT7H
65kA			65kA	65kA	1200	XT7L
65kA			65kA	65kA	3000	T8V

THIS PAGE LEFT BLANK

CATALOG

# Softstarters

PSR, PSRC, PSE and PSTX



---

**Motors use almost one third of the world's generated electricity. So it is safe to say that reliable motor operation is crucial to our modern way of life.**

---

# Contents

<b>04</b>	<b>ABB softstarters</b>
<b>06</b>	<b>Common applications for softstarters</b>
<b>08</b>	<b>Motor starting</b>
<b>12</b>	<b>Softstarters portfolio</b>
<b>16</b>	<b>Wall mounting</b>
<b>17</b>	<b>Certifications and approvals</b>
<b>52</b>	<b>PSTX</b>
<b>72</b>	<b>Fieldbus communications</b>
<b>74</b>	<b>Marketing materials and tools</b>

---

# ABB softstarters

## How we are helping the industry

A softstarter from ABB offers you several values and benefits. Whether you are a consultant, OEM, panel builder or end-user, A softstarter will add to your business value by securing motor reliability, improving installation efficiency and increasing application productivity.



SECURE  
MOTOR  
RELIABILITY

ABB softstarters help increase your motors lifetime by protecting it from electrical stress. Starting currents are easily optimized to your load, application and motor size. Over ten motor protection features are included to keep your motor safe from different load and network irregularities.



IMPROVE  
INSTALLATION  
EFFICIENCY

Reduce your installation time and panel size by having all features you need built into your softstarter. Our softstarters are easy to install thanks to their compact design and many built-in features. The built-in bypass saves energy and space while reducing heat generation. A complete motor starting solution in one unit.



INCREASE  
APPLICATION  
PRODUCTIVITY

Reduce the number of stops in your production by allowing your softstarter to do more than just starting. Our softstarters reduce the mechanical stress on your motor application, which will increase your uptime. Torque control, pump cleaning, motor brake and many other features enable you to operate your process at its full potential.



## **Xylem - South Africa**

ABB softstarters providing efficiency to the mining industry

One of Xylem's water solutions helps to prevent flooding in mines. Previous softstarters needed a lot of extra protection equipment. Xylem was looking for a simpler solution that would ensure reliability even at 3,500 meters depth. Reducing the number of components by 80 percent, shortened installation time by 60 percent. Costs cut to half has helped Xylem sell twice as many panels with softstarters as before.



**Installation time  
reduced by 60%**



**Total panel cost  
reduced by 50%**

# Common applications for softstarters

## Pumps, fans, compressors and conveyors

A softstarter can do wonders with your operations. Packed with useful features, it reduces the wear of your equipment, improve the reliability of your processes and increase overall productivity.



01 Softstarters controlling pumps



02 Softstarters controlling fans

### Pump

#### Eliminating water hammering with torque control

Water hammering is a common problem with pumps and typically results in wear in pipes and valves when starting and stopping the pump. The ABB softstarter feature torque control provides a soft pipe fill during start and eliminates water hammering during stop. The benefits are prolonged lifetime of the system and increased uptime.

#### Keep pipes and pumps clean

Many pumps risk getting clogged over time. This will cause reduced flow and increased risk of pump damage. Thanks to the feature to reverse the direction of the flow and start again with kick-start, ABB softstarters can help prevent and solve pump clogging and associated downtime.

#### Avoid running dry with underload protection

Damages due to pumps running dry can be avoided with the softstarter feature dry pump protection, called underload protection. It stops the motor which saves the pump from additional wear and contributes to prolonging its lifetime.

01



### Fans

#### Soft starting adjusted to application

Fans normally have a high moment of inertia, which makes starting tough and current high. Using an ABB softstarter, the voltage is increased gradually during start, which reduces the current and removes the inrush peak. It is possible to adjust the settings to fit almost any starting condition, from unloaded to fully loaded.

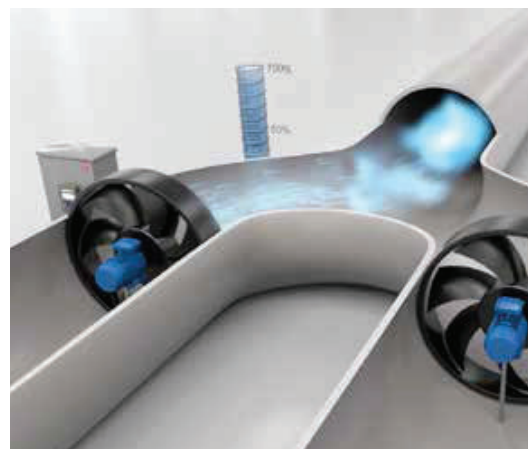
#### Fast stops with motor braking

It can also take a long time to stop a fan. With the dynamic brake feature, also called flux braking, the stopping time can be reduced. This improves process safety when the load has a high moment of inertia and makes fan operation easier for the operator.

#### Avoid unwanted movements with stand still brake

An idle fan that is rotating backwards, due to wind or airflow from another fan, can be kept still using the stand still brake. It prevents unwanted airflow and improves the control of the system without the need for an external mechanical brake.

02







03 Softstarters controlling compressors



04 Softstarters controlling conveyor belts

## Compressors

### Full control of current with current limit

Many applications are sensitive to high or variable starting currents. The feature current limit makes it possible to start the motor securely even in a weaker network, improving the availability of the equipment and system. Reducing the current means reducing the stress on cables, network and motor.

### Full voltage start for scroll compressors

For scroll compressors it is often necessary to start the motor in a very short time while still maintaining a low starting current. Full voltage start is a start mode that gives you almost a direct start but without the current peak.

### Phase reversal protection for problem-free commissioning

A motor rotating in the wrong direction, which may occur due to connecting the phases wrongly, may cause severe damage to a compressor. Using phase reversal protection, the motor won't start in the wrong direction, avoiding costly compressor downtime and repairs.

03



## Conveyors

### Avoid overheating with overload protection

Too much material on a conveyor belt may cause overload and overheating, reducing the reliability and longevity of the motor. ABB's overload protection feature shuts down the motor in case of overload, avoiding overheating.

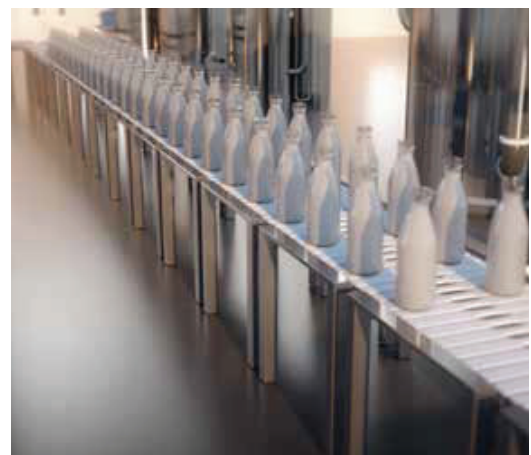
### Increased flexibility with jog with slow speed

After stopping the belt, it may be necessary to run the motor at low speed to correctly position the belt before resuming operation. The jog with slow speed feature makes it possible to position the belt manually, in both forward and reverse direction, before re-starting the belt. This improves process efficiency and eliminates the need for a variable speed drive, a considerably more expensive solution for solving the problem.

### Continuous operation with limp mode

Shorted thyristor is a possible problem for a softstarter, putting it out of operation until the component has been replaced. Using limp mode, the softstarter will continue to work with one thyristor shorted, avoiding costly unplanned stoppages.

04



# Motor starting

## Why motor starting and stopping matters

There are some common issues associated with starting and stopping electrical motors. Depending on requirement, different starting and stopping methods can be used.



### Direct-on-line

Direct-on-line starting (DOL) is the easiest and most commonly used starting method. It is suitable for stable networks and mechanically stiff and well-dimensioned shaft systems due to the high current and torque generated during start. DOL starting is uncontrolled, which means that the motor will start with maximum current and torque regardless of load type.

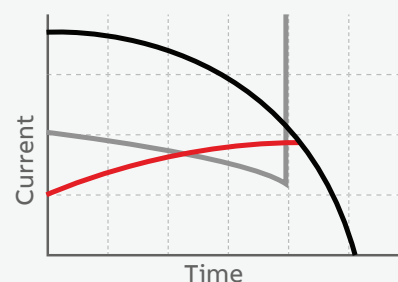
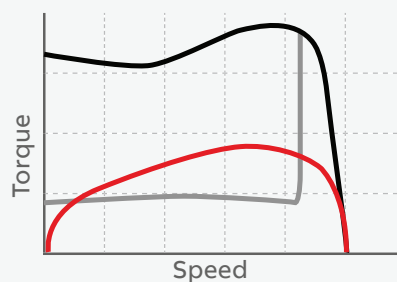


### Star-delta

A star-delta starter reduces current and torque during start. The starting current is about one third compared to direct-on-line starting, although it also reduces the starting torque to about 25 percent. Star-delta is not adjustable, so if the torque is reduced too much, the motor will not start. Current peaks will happen when switching from star to delta connection.

## Typical torque and current curves from starting a motor

— Softstarter  
— DOL  
— Star-delta





### Softstarter

Like direct-on-line and star delta starters, softstarters are used to start and stop motors in full-speed applications. It eliminates common problems associated with motor starting and stopping, including electrical surges, spikes and high inrush currents. Because it offers soft starting and stopping, a softstarter is the optimal compromise between a direct-on-line or star-delta starter and a variable speed drive in many full-speed motor applications.

### Variable speed drive

Like a softstarter, a variable speed drive (VSD) can perform soft motor starting and stopping. However, the VSD was designed primarily to control motor speed, resulting in energy efficient motor operation in variable speed applications. Using a VSD with the sole purpose of ensuring soft starting and stopping of full-speed motors can therefore be considered an unnecessarily advanced solution.

## Comparison between different starting methods

The table below describes which problems are prevented, using the most common starting methods.

	Direct on line DOL	Star-delta start Y/D	Softstarter	Drive
Reduce high inrush current	-	●	●	●
Reduce heavy wear on bearings, shafts, gear boxes, etc	-	○	●	●
Prevent slipping belts	-	○	●	●
Remove torque/current peaks	-	-	●	●
Prevent water hammering in piping system	-	-	●	●
Need of variable speed control	-	-	-	●

● = standard, ○ = reduced, - = not available

---

# ABB softstarters

## A part of your motor starting solution

Motor starting requires several components to work perfectly together. ABB is a one-stop shop for motor starting, offering all the necessary components and complete motor starting solutions, proven together in numerous installations worldwide.

---

### Can I use a softstarter on a ship?

**ABB softstarters PSE and PSTX have marine approvals and are certified for marine environment.**

Ships uses IT-networks which means that there is a floating electrical ground. It is possible to use an ABB softstarter in such a network but it is recommended to not connect the functional ground on the softstarter to the ship to avoid disturbances from the network to effect the electronics inside the softstarter.

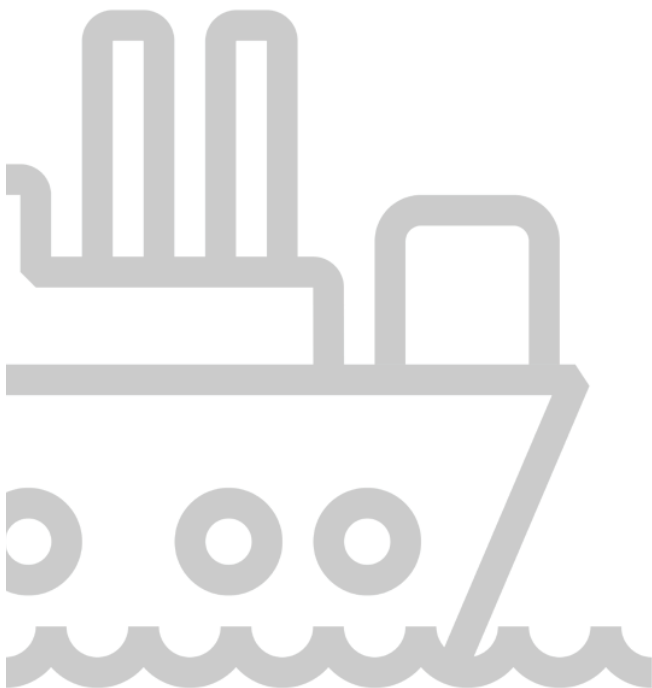
---

### Can I use a softstarter for an ATEX motor?

**ABB softstarter PSTX can be used to start ATEX classified motors in EX environments. However, always consult with your local ATEX certified expert for component selection and system design. Listed below are some points for consideration (but not limited to):**

- Locate the softstarter outside the EX area, or in an ATEX approved panel
- The PSTX Softstarter has not a specific ATEX approved motor overload protection. The standard (global or local) may require this depending on the type of installation. If the standard requires it an external ATEX approved EOL/TOL should be considered
- Select softstarter according to normal or heavy-duty start depending on your application.
- A line/fault contactor can be used in case of failure
- Determine the short circuit coordination rating and type that is needed for the application. Typically, there should be a coordination for a device, for example a fault contactor, that won't get welded shut in case of short circuit.

Always consult with certified ATEX expert and follow local laws and regulations that applies.



# Typical motor control cabinet

## Overview



**Power supply CP-C.1**  
Power reserve and switching of high peak currents help maximize system availability. Rated output voltage 24 V DC



**Safety relay**  
The Sentry safety relay series are powerful and easy to use. They can monitor E-stops or other type of safety devices up to PLe/SIL3.



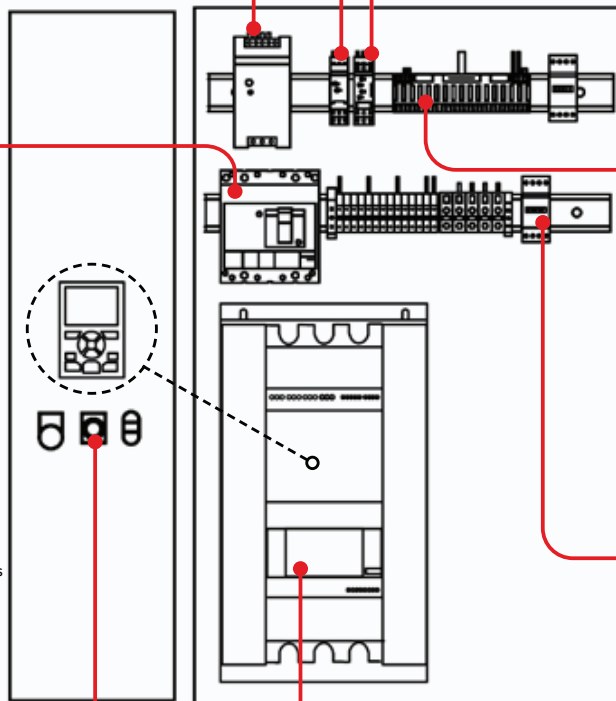
**Liquid level monitoring relays CM-ENS**  
- Monitoring and signalling the water level



**Short circuit breaker MCCB**  
Short circuit protection of motor  
Possibility for electrical isolation



**Switch fuse**  
- Short circuit protection of downstream devices  
- Type 2 coordination when using rapid fuses  
- Making and breaking of motor loads (AC-23A)  
- Safe isolation



**PLC AC500**  
- Automatic control  
- Remote communication



**Line contactor AF**  
- Isolation at stop  
- Isolation at faults  
- Emergency stop  
- Back-up DOL starter



**Pilot devices**  
- Remote control of motor  
- Indication of Softstarter and motor status with light and sound  
- Emergency stop of motor



**Softstarter**  
- Soft start and stop with reduced current  
- Features to improve process productivity  
- Detachable keypad for front door mounting on a panel

# Softstarters portfolio

## Overview



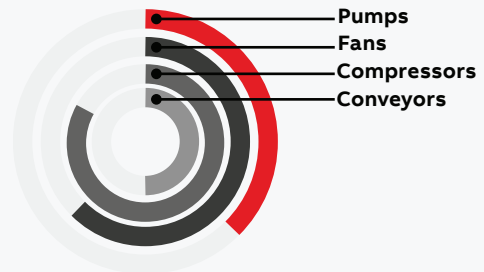
### PSR - The compact range

PSR is our most compact softstarter with basic benefits and values. PSR can handle up to 100 starts per hour. Suitable for small motors.

**Current:** 3 A... 105 A

**Main voltage:** 208 V... 600 V

#### Application features



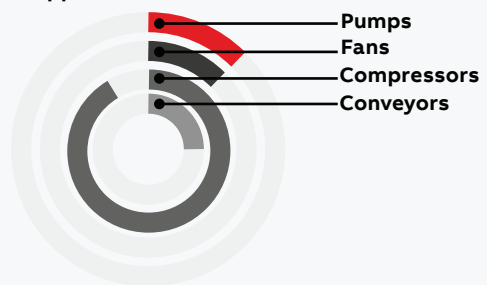
### PSRC - For scroll compressor

PSRC is fast and easy to install with fixed settings. Designed for scroll compressors results in less stress on the compressor reducing the maintenance cost to a minimum.

**Current:** 3 A... 105 A

**Main voltage:** 208 V... 600 V

#### Application features



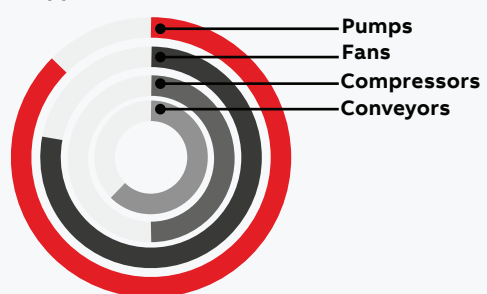
### PSE - The efficient range

The new generation PSE is a true general purpose softstarter. It's a perfect balance between high starting capacity and cost efficiency. Now featuring built-in fieldbus communication.

**Current:** 18 A... 370 A

**Main voltage:** 208 V... 600 V

#### Application features



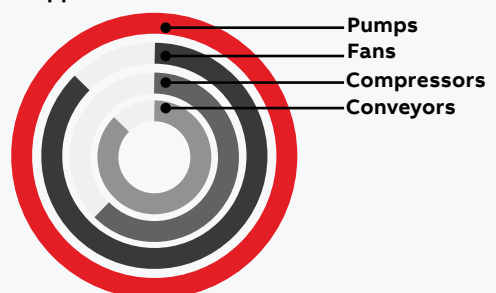
### PSTX - The advanced range

PSTX is the most complete alternative for any motor starting application. Featuring built-in modbus and anybus modules that support all major communication protocols.

**Current:** 30 A... 1250 A

**Main voltage:** 208 V... 690 V

#### Application features



# Softstarters selection

ABB softstarters offering consists of four ranges, covering every need. The products help you secure motor reliability, improve installation efficiency and increase application productivity.



Product range overview	PSR	PSRC	PSE	PSTX
Technology	Basic	Basic	General	Advanced
Motor size	Small – up to 105 A	Small – up to 105 A	Medium – up to 370 A	Large – up to 1250 A
Installation efficiency	Basic	Basic	Medium	High
Motor protection	-	-	Medium	High
Application	All	Scroll compressor	All	All
Application enhancement	Basic	Basic	Medium	High
Fieldbus Communication	Yes	Yes	Yes	Yes
Anybus Communication	-	-	-	Yes
Torque control	-	-	Yes	Yes
Heavy duty starts	-	-	Yes	Yes
Frame sizes	A, B, C, D	A, B, C, D	A, B, C	A, B, C, D, E, F

## Selection process

# 1

### Determine softstarter series

First, determine the softstarter series that fulfill the needs of the application and motor. Use the guide on the left to explore the three series and the power range each one covers.

# 2

### Match the softstarter size with the motor current

When the softstarter series is selected, the correct size should now be determined. The selection of a softstarter is based on the current. Find the softstarter that corresponds to the motor current.

# 3

### Fine tune and select the correct size

The last step is to fine tune the selection, and there are three different factors to consider:

- Normal or a heavy load: If the load is characterized as a heavy load, select the next size softstarter in the series.
- High ambient temperature
- High altitude

Use the equations and the table on the right to find the correct de-rating equation.

### Altitude formula

De-rate for altitudes between 1000-4000 m or 3280-13123 ft with the following equations for all softstarters:

In meters: % of I<sub>e</sub> = 100 – (x-1000)/150

In feet: % of FLA = 100 – (y-3280)/480

Where x/y is the actual altitude in m/ft

### Temperature equations

PSTX and PSR In Celsius: 40...60 °C: Reduce I<sub>e</sub> with 0.8%/°C

PSTX and PSR In Fahrenheit: 104...140 °F: Reduce FLA with 0.44%/°F

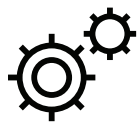
PSE In Celsius: 40...60 °C: Reduce I<sub>e</sub> with 0.6%/°C

PSE In Fahrenheit: 104...140 °F: Reduce FLA with 0.33%/°F

### Typical applications

Normal duty start	Heavy duty
Bow thrusters	Centrifugal fan
Centrifugal pump	Conveyor belt (long)
Compressors	Crusher
Conveyor belt (short)	Stirrer
Elevator	Sawmill

# Softstarters benefits and features



## SECURE MOTOR RELIABILITY

### Increase your motors lifetime...

With ABB softstarters, starting currents are easily optimized to your load, application and motor size.

### ...by protecting it from electrical stresses.

Over ten motor protection features are included to keep your motor safe from overloads and network irregularities.

Softstarter features	PSR	PSE	PSTX
Current limit	-	●	●
Current limit ramp and dual current limit	-	-	●
Electronic motor overload protection	-	●	●
Dual overload protection	-	-	●
Underload protection	-	●	●
Power factor underload protection	-	-	●
Locked rotor protection	-	●	●
Current/Voltage imbalance protection	-	-	●
Phase reversal protection	-	-	●
Customer defined protection	-	-	●
Motor heating	-	-	●
PTC/PT100 input for motor protection	-	-	●
Overvoltage/undervoltage protection	-	-	●
Earth-fault protection	-	-	●

● = standard, ○ = option, - = not available



## IMPROVE INSTALLATION EFFICIENCY

### Reduce your installation time and panel size...

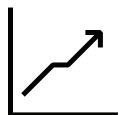
ABB softstarters are easy to install thanks to their compact design and many built-in features.

### ...by having everything that you need built in.

Built-in bypass saves energy and space while reducing heat generation: a complete motor starting solution in one unit designed and verified by ABB.

Softstarter features	PSR	PSE	PSTX
Built-in bypass	●	●	●
Inside-delta connection possible	-	-	●
Graphical display and keypad	-	●	●
Detachable keypad	-	-	●
Motor runtime and start count	-	-	●
Programmable warning functions	-	-	●
Diagnostics	-	-	●
Overload time-to-trip	-	-	●
Overload time-to-cool	-	-	●
Analog output	-	●	●
Fieldbus communication	○	●	●
Event log	-	○	●
Multiple languages	-	-	17
Electricity metering	-	-	●

● = standard, ○ = option, - = not available



## INCREASE APPLICATION PRODUCTIVITY

### Reduce the number of production stops...

ABB softstarters reduce mechanical stress on your application which increases uptime.

### ...by letting the softstarter do more than just starting.

Torque control, pump cleaning, motor break and many more features enables you to use your process to its full potential.

Softstarter features	PSR	PSE	PSTX
Torque control	-	●	●
Torque limit	-	-	●
Coated PCBA	-	●	●
Limp mode	-	-	●
Jog with slow speed forward/ reverse	-	-	●
Dynamic brake	-	-	●
Stand still brake	-	-	●
Sequence start	-	-	●
Full voltage start	-	-	●
Kick start	-	●	●
Automatic pump cleaning	-	-	●

● = standard, ○ = option, - = not available



---

# Case studies

## **Tasmanian salmon operation keeps its fish cool with ABB softstarters**

Tassal upgrades the motor control center in Australia's biggest land-based salmon hatchery with ABB Softstarters, ensuring the continuous operation of its water chillers. For more information visit: [Link](#)

## **Lower the inrush current by 50%**

## **Xylem - South Africa ABB softstarters providing efficiency to the mining industry**

Xylem reducing the number of components by 80%, shortened installation time by 60%. Costs cut to half has helped Xylem sell twice as many panels with softstarters as before. For more information visit: [Link](#)

## **Total panel costs reduced by 50%**

## **Indian tourist town is pumped up over ABB Softstarters that help uninterrupted water supply**

Shimla has cut pipeline damage 50% using Softstarters to help lift water thousands of feet from a dam to quench the thirst of millions. For more information visit: [Link](#)

## **Pipeline damage reduced by 50%**

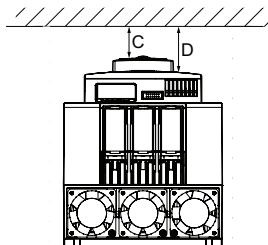


# Wall mounting

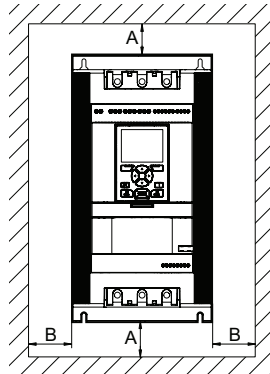
## Instructions

Product	Minimum distance to wall mm (in)			
	A	B	C	D
<b>PSR</b>				
PSR3 ... PSR16	0	0	25 (0.98)	N/A
PSR25 ... PSR30	0	0	25 (0.98)	N/A
PSR37 ... PSR45	0	0	25 (0.98)	N/A
PSR60 ... PSR105	0	0	25 (0.98)	N/A
<b>PSRC</b>				
PSR3 ... PSR16	0	0	25 (0.98)	N/A
PSR25 ... PSR30	0	0	25 (0.98)	N/A
PSR37 ... PSR45	0	0	25 (0.98)	N/A
PSR60 ... PSR105	0	0	25 (0.98)	N/A
<b>PSE</b>				
PSE18 ... PSE105	100 (3.94)	10 (0.39)	20 (0.79)	N/A
PSE142 ... PSE170	100 (3.94)	10 (0.39)	20 (0.79)	N/A
PSE210 ... PSE370	100 (3.94)	10 (0.39)	20 (0.79)	N/A
<b>PSTX</b>				
PSTX30 ... PSTX105	100 (3.94)	10 (0.39)	20 (0.79)	35 (1.38)
PSTX142 ... PSTX170	100 (3.94)	10 (0.39)	20 (0.79)	35 (1.38)
PSTX210 ... PSTX370	100 (3.94)	10 (0.39)	20 (0.79)	35 (1.38)
PSTX470 ... PSTX570	150 (5.91)	15 (0.59)	20 (0.79)	35 (1.38)
PSTX720 ... PSTX840	150 (5.91)	15 (0.59)	20 (0.79)	35 (1.38)
PSTX1050 ... PSTX1250	150 (5.91)	15 (0.59)	20 (0.79)	35 (1.38)

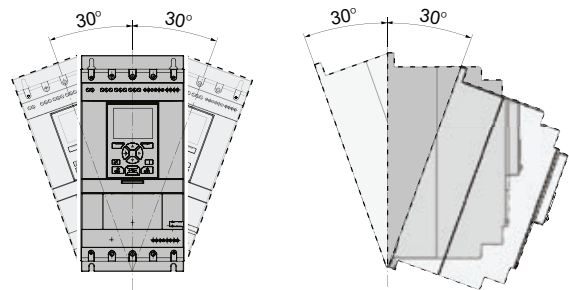
Minimum distance to front



Minimum distance to wall
















Maximum mounting angle



# Certifications and approvals

The table below shows the certifications and approvals for ABB softstarters. For other certifications and/or approvals, please contact ABB.

Certifications and approvals													
Abbreviation approved in	Certifications							Approvals: ship classification societies					
													
	CE EU	cULus Canada USA	CCC China	EAC Russia	ANCE Mexico	C-tick Australia	KC Korea	ABS	DNV	Lloyd's Register	CCS	PRS	Class NK
PSR3 ... PSR105	•	•	•	•	•	•	•	—	—	—	—	—	—
PSRC3 ... PSRC105	•	•	•	•	•	•	•	—	—	—	—	—	—
PSE18 ... PSE370	•	•	•	•	•	•	•	•	•	•	•	•	•
PSTX30 ... PSTX1250	•	•	•	•	•	•	•	•	•	•	•	•	•

Note: • Standard design approved, the products wear the certification mark when it is required.

## Directives and standards

No. 2006/95/EC	Low voltage equipment
No. 2004/108/EC	Electromagnetic compatibility
EN 60947-1	Low-voltage switchgear and controlgear - Part 1: General rules
EN 60947-4-2	AC semiconductor motor controllers and starters
UL 508	Industrial Control Equipment
CSA C22.2 No 14	Industrial Control Equipment

## Items included in the box with the softstarter

	Multi-language manual	Terminal kit	Cable and mounting kit for detachable keypad
PSR3 ... PSR105	•	○	—
PSRC3 ... PSRC105	•	○	—
PSE18 ... PSE105	•	○	—
PSE142...PSE370	•	—	—
PSTX30 ... PSTX105	•	○	•
PSTX142...PSTX1250	•	—	•

● = included, ○ = built-in, — = not included

—  
**The PSTX combines many years of research and product development with extensive knowledge of application specific requirements and needs. It is our latest advancement in motor control & protection, and it adds new functionality and increased reliability.**

---

# PSTX

## The advanced range

<b>54</b>	<b>Introduction</b>
<b>56</b>	<b>Coordination examples</b>
<b>58</b>	<b>Ordering details</b>
<b>62</b>	<b>Accessories</b>
<b>64</b>	<b>Technical data</b>
<b>68</b>	<b>Dimensions</b>
<b>70</b>	<b>Circuit diagrams</b>

# PSTX - The advanced range

## Introduction



### Technical specifications

- Rated operational current: 30... 1250 A (inside-delta: 2160 A)
- Operational voltage: 208... 690 V AC
- Wide rated control supply voltage: 100... 250 V, 50/60 Hz

### Features

- Both in-line and inside-delta connection
- Detachable keypad rated IP66 (4X outdoor)
- Graphical display with 17 languages for easy setup and operation
- Built-in bypass for energy saving and easy installation
- Analog output for measurement of current, voltage, power factor etc.

### Protections

- Complete motor protection

### Communication

- Built-in Modbus RTU
- Support for all major communication protocols



SECURE  
MOTOR  
RELIABILITY

### Complete motor protection

The PSTX offers complete motor protection in only one unit and is able to handle both load and network irregularities. PT-100, earth fault protection and over/under voltage protection along with many other functions keep your motor safer than ever. PSTX also offers three types of current limit: standard, dual and ramp. This gives you full control of your motor during start. It also allows you to use your motor in weaker networks.



IMPROVE  
INSTALLATION  
EFFICIENCY

### Built-in bypass saves time and energy

When reaching full speed, the PSTX will activate its bypass. This saves energy while reducing the softstarters heat generation. On the PSTX, the bypass is built in and verified by ABB, saving you time during installation and space in your panel.



INCREASE  
APPLICATION  
PRODUCTIVITY

### Complete control of pumps

Time to use your processes to their full potential. The PSTX features many application enhancing features, including torque control: the most efficient way to start and stop pumps. The pump cleaning feature can reverse pump flow and clean out pipes, securing uptime of your pump system.

**Heavy duty design** to handle heavy applications such as centrifugal fan, mill and mixers.

**Jog with slow speed forward & reverse**

The slow speed forward and backward jog feature will make you more flexible when operating e.g. conveyor belts and cranes.

**Torque control function** the absolutely best possible stop of pumps without water hammering and pressure surges.

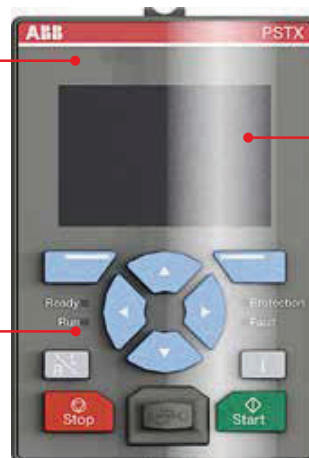


**The HMI is user-friendly and have a clear display that** saves you time and resources during both setup and operation. The detachable keypad is standard on all PSTX softstarters with IP66 and 4x outdoor for tough environments.

**Coated PCB** protecting from dust, moist and corrosive atmosphere.

**Customize your own specific home screens** (up to seven different). The PSTX has 17 pre-installed languages. You can use your customized home screens to show status information important to your process and hide information that is not.

**Detachable keypad** as standard. It can be placed on your panel door, meaning you do not have to interrupt your process in order to read status information or to change settings.



**Easy to learn** with a large graphical display along with built-in assistants make learning how to handle the PSTX fun and simple. The interface resembles other interfaces from ABB which will streamline and help with training of field personnel.

## PSTX - The advanced range

Coordination examples



### Normal start In-line connected

Softstarter	Technical data				Using manual motor starter or MCCB, type 1 coordination will be achieved. <sup>1)</sup>	Using gG fuses, type 1 coordination will be achieved. To achieve type 2 coordination, semiconductor fuses must be used. <sup>1)</sup>	Suitable switch fuse for the recommended semiconductor fuses. <sup>1)</sup>	The line contactor will be required for the softstarter itself but often used to open if OL trips <sup>1)</sup>
	IEC kW (400V)	IEC max A	UL HP (440-480 V)	UL max FLA				
PSTX30	15	30	20	28	XT2S160	170M1567	OS32G	AF30
PSTX37	18.5	37	25	34	XT2S160	170M1568	OS63G	AF38
PSTX45	22	45	30	42	XT2S160	170M1569	OS63G	AF52
PSTX60	30	60	40	60	XT2S160	170M1569	OS63G	AF65
PSTX72	37	72	50	68	XT2S160	170M1571	OS125G	AF80
PSTX85	45	85	60	80	XT2S160	170M1572	OS125G	AF96
PSTX105	55	106	75	104	XT2S160	170M3819	OS250	AF116
PSTX142	75	143	100	130	XT2S160	170M5810	OS400	AF146
PSTX170	90	171	125	169	XT4S250	170M5812	OS400	AF190
PSTX210	110	210	150	192	T4S320	170M5812	OS400	AF265
PSTX250	132	250	200	248	T5S400	170M5813	OS400	AF265
PSTX300	160	300	250	302	T5S400	170M6812	OS630	AF305
PSTX370	200	370	300	361	T5S630	170M6813	OS630	AF370
PSTX470	250	470	400	480	T7S800	170M6813	OS630	AF580
PSTX570	315	570	500	590	T7S800	170M6814	OS630	AF580
PSTX720	400	720	600	720	T7S1250	170M8554	OS800	AF750
PSTX840	450	840	700	840	T7S1250	170M6018	-	AF1350
PSTX1050	560	1050	900	1062	E2.2N 2000	170M6020	-	AF1650
PSTX1250	710	1250	1000	1250	E2.2N 2000	170M6021	-	-

<sup>1)</sup> These is an example of coordination. For more examples see: <https://applications.it.abb.com/SOC/Page/Selection.aspx>

<sup>2)</sup> When using a softstarter in a network with high harmonic disturbances, we recommend to use a line-contactor. Please check the information in the Installation manual for more details.



### Coordination tables (SOC) >

For more examples of coordination visit the online tool for coordination with short circuit protection, overload protection and line contactor.



## PSTX - The advanced range

Normal starts, class 10, in-line

Ordering details



PSTX30... PSTX105   PSTX142... PSTX170   PSTX210... PSTX370   PSTX470... PSTX570   PSTX720... PSTX840   PSTX1050... PSTX1250

Rated operational voltage  $U_e$ , 208...600 V , rated control supply voltage  $U_s$ , 100...250 V AC, 50/60 Hz

IEC rated operational power			current $I_e$ A	UL/CSA rated operational power				FLA	Type	Order code	Net Weight (kg)	Net Weight (lb)
400V $P_e$ kW	500V $P_e$ kW	690V $P_e$ kW		200/208V $P_e$ hp	220/240V $P_e$ hp	440/480V $P_e$ hp	550/600V $P_e$ hp					
15	18.5	-	30	7.5	10	20	25	28	PSTX30-600-70	1SFA898103R7000	4.6	10.1
18.5	22	-	37	10	10	25	30	34	PSTX37-600-70	1SFA898104R7000	4.6	10.1
22	25	-	45	10	15	30	40	42	PSTX45-600-70	1SFA898105R7000	4.6	10.1
30	37	-	60	20	20	40	50	60	PSTX60-600-70	1SFA898106R7000	4.6	10.1
37	45	-	72	20	25	50	60	68	PSTX72-600-70	1SFA898107R7000	4.7	10.4
45	55	-	85	25	30	60	75	80	PSTX85-600-70	1SFA898108R7000	4.7	10.4
55	75	-	106	30	40	75	100	104	PSTX105-600-70	1SFA898109R7000	4.7	10.4
75	90	-	143	40	50	100	125	130	PSTX142-600-70	1SFA898110R7000	7.0	15.4
90	110	-	171	50	60	125	150	169	PSTX170-600-70	1SFA898111R7000	8.9	19.6
110	132	-	210	60	75	150	200	192	PSTX210-600-70	1SFA898112R7000	13.3	29.3
132	160	-	250	75	100	200	250	248	PSTX250-600-70	1SFA898113R7000	15.5	34.2
160	200	-	300	100	100	250	300	302	PSTX300-600-70	1SFA898114R7000	15.5	34.2
200	257	-	370	125	150	300	350	361	PSTX370-600-70	1SFA898115R7000	15.5	34.2
250	315	-	470	150	200	400	500	480	PSTX470-600-70	1SFA898116R7000	25.0	55.1
315	400	-	570	200	200	500	600	590	PSTX570-600-70	1SFA898117R7000	27.0	59.5
400	500	-	720	250	300	600	700	720	PSTX720-600-70	1SFA898118R7000	46.5	102.5
450	600	-	840	300	350	700	800	840	PSTX840-600-70	1SFA898119R7000	46.5	102.5
560	730	-	1050	400	450	900	1000	1062	PSTX1050-600-70	1SFA898120R7000	62.3	137.3
710	880	-	1250	400	500	1000	1200	1250	PSTX1250-600-70	1SFA898121R7000	63.3	137.3

Rated operational voltage  $U_e$ , 208...690 V , rated control supply voltage  $U_s$ , 100...250 V AC, 50/60 Hz

IEC rated operational power			current $I_e$ A	UL/CSA rated operational power				FLA	Type	Order code	Net Weight (kg)	Net Weight (lb)
400V $P_e$ kW	500V $P_e$ kW	690V $P_e$ kW		200/208V $P_e$ hp	220/240V $P_e$ hp	440/480V $P_e$ hp	550/600V $P_e$ hp					
15	18.5	25	30	7.5	10	20	25	28	PSTX30-690-70	1SFA898203R7000	4.6	10.1
18.5	22	30	37	10	10	25	30	34	PSTX37-690-70	1SFA898204R7000	4.6	10.1
22	25	37	45	10	15	30	40	42	PSTX45-690-70	1SFA898205R7000	4.6	10.1
30	37	55	60	20	20	40	50	60	PSTX60-690-70	1SFA898206R7000	4.6	10.1
37	45	59	72	20	25	50	60	68	PSTX72-690-70	1SFA898207R7000	4.7	10.4
45	55	75	85	25	30	60	75	80	PSTX85-690-70	1SFA898208R7000	4.7	10.4
55	75	90	106	30	40	75	100	104	PSTX105-690-70	1SFA898209R7000	4.7	10.4
75	90	132	143	40	50	100	125	130	PSTX142-690-70	1SFA898210R7000	7.0	15.4
90	110	160	171	50	60	125	150	169	PSTX170-690-70	1SFA898211R7000	8.9	19.6
110	132	184	210	60	75	150	200	192	PSTX210-690-70	1SFA898212R7000	13.3	29.3
132	160	220	250	75	100	200	250	248	PSTX250-690-70	1SFA898213R7000	15.5	34.2
160	200	257	300	100	100	250	300	302	PSTX300-690-70	1SFA898214R7000	15.5	34.2
200	257	355	370	125	150	300	350	361	PSTX370-690-70	1SFA898215R7000	15.5	34.2
250	315	450	470	150	200	400	500	480	PSTX470-690-70	1SFA898216R7000	25.0	55.1
315	400	560	570	200	200	500	600	590	PSTX570-690-70	1SFA898217R7000	27.0	59.5
400	500	710	720	250	300	600	700	720	PSTX720-690-70	1SFA898218R7000	46.5	102.5
450	600	800	840	300	350	700	800	840	PSTX840-690-70	1SFA898219R7000	46.5	102.5
560	730	1000	1050	400	450	900	1000	1062	PSTX1050-690-70	1SFA898220R7000	62.3	137.3
710	880	1200	1250	400	500	1000	1200	1250	PSTX1250-690-70	1SFA898221R7000	63.3	137.3

## PSTX - The advanced range

Heavy-duty starts, class 30, in-line

Ordering details



PSTX30... PSTX105   PSTX142... PSTX170   PSTX210... PSTX370   PSTX470... PSTX570   PSTX720... PSTX840   PSTX1050... PSTX1250

Rated operational voltage  $U_e$ , 208...600 V, rated control supply voltage  $U_s$ , 100...250 V AC, 50/60 Hz

IEC rated operational power			current $I_e$ A	UL/CSA rated operational power				FLA	Type	Order code	Net Weight (kg)	Net Weight (lb)
400V $P_e$ kW	500V $P_e$ kW	690V $P_e$ kW		200/208V $P_e$ hp	220/240V $P_e$ hp	440/480V $P_e$ hp	550/600V $P_e$ hp					
11	15	-	22	5	7.5	15	20	25	PSTX30-600-70	1SFA898103R7000	4.6	10.1
15	18.5	-	30	7.5	10	20	25	28	PSTX37-600-70	1SFA898104R7000	4.6	10.1
18.5	22	-	37	10	10	25	30	34	PSTX45-600-70	1SFA898105R7000	4.6	10.1
22	25	-	45	10	15	30	40	42	PSTX60-600-70	1SFA898106R7000	4.6	10.1
30	37	-	60	20	20	40	50	60	PSTX72-600-70	1SFA898107R7000	4.7	10.4
37	45	-	72	20	25	50	60	68	PSTX85-600-70	1SFA898108R7000	4.7	10.4
45	55	-	85	25	30	60	75	80	PSTX105-600-70	1SFA898109R7000	4.7	10.4
55	75	-	106	30	40	75	100	104	PSTX142-600-70	1SFA898110R7000	7.0	15.4
75	90	-	143	40	50	100	125	130	PSTX170-600-70	1SFA898111R7000	8.9	19.6
90	110	-	171	50	60	125	150	169	PSTX210-600-70	1SFA898112R7000	13.3	29.3
110	132	-	210	60	75	150	200	192	PSTX250-600-70	1SFA898113R7000	15.5	34.2
132	160	-	250	75	100	200	250	248	PSTX300-600-70	1SFA898114R7000	15.5	34.2
160	200	-	300	100	100	250	300	302	PSTX370-600-70	1SFA898115R7000	15.5	34.2
200	257	-	370	125	150	300	350	361	PSTX470-600-70	1SFA898116R7000	25.0	55.1
250	315	-	470	150	200	400	500	480	PSTX570-600-70	1SFA898117R7000	27.0	59.5
315	400	-	570	200	200	500	600	590	PSTX720-600-70	1SFA898118R7000	46.5	102.5
400	500	-	720	250	300	600	700	720	PSTX840-600-70	1SFA898119R7000	46.5	102.5
450	600	-	840	300	350	700	800	840	PSTX1050-600-70	1SFA898120R7000	62.3	137.3
560	730	-	1050	400	450	900	1000	1062	PSTX1250-600-70	1SFA898121R7000	63.3	137.3

Rated operational voltage  $U_e$ , 208...690 V, rated control supply voltage  $U_s$ , 100...250 V AC, 50/60 Hz

IEC rated operational power			current $I_e$ A	UL/CSA rated operational power				FLA	Type	Order code	Net Weight (kg)	Net Weight (lb)
400V $P_e$ kW	500V $P_e$ kW	690V $P_e$ kW		200/208V $P_e$ hp	220/240V $P_e$ hp	440/480V $P_e$ hp	550/600V $P_e$ hp					
11	15	18.5	22	5	7.5	15	20	25	PSTX30-690-70	1SFA898203R7000	4.6	10.1
15	18.5	25	30	7.5	10	20	25	28	PSTX37-690-70	1SFA898204R7000	4.6	10.1
18.5	22	30	37	10	10	25	30	34	PSTX45-690-70	1SFA898205R7000	4.6	10.1
22	25	37	44	10	15	30	40	42	PSTX60-690-70	1SFA898206R7000	4.6	10.1
30	37	55	60	20	20	40	50	60	PSTX72-690-70	1SFA898207R7000	4.7	10.4
37	45	59	72	20	25	50	60	68	PSTX85-690-70	1SFA898208R7000	4.7	10.4
45	55	75	85	25	30	60	75	80	PSTX105-690-70	1SFA898209R7000	4.7	10.4
55	75	90	106	30	40	75	100	104	PSTX142-690-70	1SFA898210R7000	7.0	15.4
75	90	132	143	40	50	100	125	130	PSTX170-690-70	1SFA898211R7000	8.9	19.6
90	110	160	171	50	60	125	150	169	PSTX210-690-70	1SFA898212R7000	13.3	29.3
110	132	184	210	60	75	150	200	192	PSTX250-690-70	1SFA898213R7000	15.5	34.2
132	160	220	250	75	100	200	250	248	PSTX300-690-70	1SFA898214R7000	15.5	34.2
160	200	257	300	100	100	250	300	302	PSTX370-690-70	1SFA898215R7000	15.5	34.2
200	257	355	370	125	150	300	350	361	PSTX470-690-70	1SFA898216R7000	25.0	55.1
250	315	450	470	150	200	400	500	480	PSTX570-690-70	1SFA898217R7000	27.0	59.5
315	400	560	570	200	200	500	600	590	PSTX720-690-70	1SFA898218R7000	46.5	102.5
400	500	710	720	250	300	600	700	720	PSTX840-690-70	1SFA898219R7000	46.5	102.5
450	600	800	840	300	350	700	800	840	PSTX1050-690-70	1SFA898220R7000	62.3	137.3
560	730	1000	1050	400	450	900	1000	1062	PSTX1250-690-70	1SFA898221R7000	63.3	137.3

## PSTX - The advanced range

Normal starts, class 10, inside delta

Ordering details



PSTX30... PSTX105

PSTX142... PSTX170

PSTX210... PSTX370

PSTX470... PSTX570

PSTX720... PSTX840

PSTX1050... PSTX1250

Rated operational voltage  $U_e$ , 208...600 V, rated control supply voltage  $U_s$ , 100...250 V AC, 50/60 Hz

IEC rated operational power			current $I_e$ A	UL/CSA rated operational power				FLA	Type	Order code	Net Weight (kg)	Net Weight (lb)
400V $P_e$ kW	500V $P_e$ kW	690V $P_e$ kW		200/208V $P_e$ hp	220/240V $P_e$ hp	440/480V $P_e$ hp	550/600V $P_e$ hp					
25	30	-	52	10	15	30	40	48	PSTX30-600-70	1SFA898103R7000	4.6	10.1
30	37	-	64	15	20	40	50	58	PSTX37-600-70	1SFA898104R7000	4.6	10.1
37	45	-	76	20	25	50	60	72	PSTX45-600-70	1SFA898105R7000	4.6	10.1
55	75	-	105	30	40	75	100	103	PSTX60-600-70	1SFA898106R7000	4.6	10.1
59	80	-	124	30	40	75	100	117	PSTX72-600-70	1SFA898107R7000	4.7	10.4
75	90	-	147	40	50	100	125	138	PSTX85-600-70	1SFA898108R7000	4.7	10.4
90	110	-	181	60	60	150	150	180	PSTX105-600-70	1SFA898109R7000	4.7	10.4
132	160	-	245	75	75	150	200	225	PSTX142-600-70	1SFA898110R7000	7.0	15.4
160	200	-	300	75	100	200	250	292	PSTX170-600-70	1SFA898111R7000	8.9	19.6
184	250	-	360	100	125	250	300	332	PSTX210-600-70	1SFA898112R7000	13.3	29.3
220	295	-	430	150	150	350	450	429	PSTX250-600-70	1SFA898113R7000	15.5	34.2
257	355	-	515	150	200	450	500	523	PSTX300-600-70	1SFA898114R7000	15.5	34.2
355	450	-	640	200	250	500	600	625	PSTX370-600-70	1SFA898115R7000	15.5	34.2
450	600	-	814	250	300	600	700	830	PSTX470-600-70	1SFA898116R7000	25.0	55.1
540	700	-	987	300	350	700	800	1020	PSTX570-600-70	1SFA898117R7000	27.0	59.5
710	880	-	1247	400	500	1000	1200	1240	PSTX720-600-70	1SFA898118R7000	46.5	102.5
800	1000	-	1455	500	600	1200	1500	1450	PSTX840-600-70	1SFA898119R7000	46.5	102.5
1000	1250	-	1810	600	700	1500	1800	1830	PSTX1050-600-70	1SFA898120R7000	62.3	137.3
1200	1500	-	2160	800	900	1800	2000	2160	PSTX1250-600-70	1SFA898121R7000	63.3	137.3

Rated operational voltage  $U_e$ , 208...690 V, rated control supply voltage  $U_s$ , 100...250 V AC, 50/60 Hz

IEC rated operational power			current $I_e$ A	UL/CSA rated operational power				FLA	Type	Order code	Net Weight (kg)	Net Weight (lb)
400V $P_e$ kW	500V $P_e$ kW	690V $P_e$ kW		200/208V $P_e$ hp	220/240V $P_e$ hp	440/480V $P_e$ hp	550/600V $P_e$ hp					
25	30	45	52	10	15	30	40	48	PSTX30-690-70	1SFA898203R7000	4.6	10.1
30	37	55	64	15	20	40	50	58	PSTX37-690-70	1SFA898204R7000	4.6	10.1
37	45	59	76	20	25	50	60	72	PSTX45-690-70	1SFA898205R7000	4.6	10.1
55	75	90	105	30	40	75	100	103	PSTX60-690-70	1SFA898206R7000	4.6	10.1
59	80	110	124	30	40	75	100	117	PSTX72-690-70	1SFA898207R7000	4.7	10.4
75	90	132	147	40	50	100	125	138	PSTX85-690-70	1SFA898208R7000	4.7	10.4
90	110	160	181	60	60	150	150	180	PSTX105-690-70	1SFA898209R7000	4.7	10.4
132	160	220	245	75	75	150	200	225	PSTX142-690-70	1SFA898210R7000	7.0	15.4
160	200	257	300	75	100	200	250	292	PSTX170-690-70	1SFA898211R7000	8.9	19.6
184	250	315	360	100	125	250	300	332	PSTX210-690-70	1SFA898212R7000	13.3	29.3
220	295	400	430	150	150	350	450	429	PSTX250-690-70	1SFA898213R7000	15.5	34.2
257	355	500	515	150	200	450	500	523	PSTX300-690-70	1SFA898214R7000	15.5	34.2
355	450	600	640	200	250	500	600	625	PSTX370-690-70	1SFA898215R7000	15.5	34.2
450	600	800	814	250	300	600	700	830	PSTX470-690-70	1SFA898216R7000	25.0	55.1
540	700	960	987	300	350	700	800	1020	PSTX570-690-70	1SFA898217R7000	27.0	59.5
710	880	1200	1247	400	500	1000	1200	1240	PSTX720-690-70	1SFA898218R7000	46.5	102.5
800	1000	1400	1455	500	600	1200	1500	1450	PSTX840-690-70	1SFA898219R7000	46.5	102.5
1000	1250	1700	1810	600	700	1500	1800	1830	PSTX1050-690-70	1SFA898220R7000	62.3	137.3
1200	1500	2000	2160	800	900	1800	2000	2160	PSTX1250-690-70	1SFA898221R7000	63.3	137.3

## PSTX - The advanced range

Heavy-duty starts, class 30, inside delta

Ordering details



PSTX30... PSTX105

PSTX142... PSTX170

PSTX210... PSTX370

PSTX470... PSTX570

PSTX720... PSTX840

PSTX1050... PSTX1250

Rated operational voltage  $U_e$ , 208...600 V, rated control supply voltage  $U_s$ , 100...250 V AC, 50/60 Hz

IEC rated operational power			current $I_e$ A	UL/CSA rated operational power				FLA	Type	Order code	Net Weight (kg)	Net Weight (lb)
400V $P_e$ kW	500V $P_e$ kW	690V $P_e$ kW		200/208V $P_e$ hp	220/240V $P_e$ hp	440/480V $P_e$ hp	550/600V $P_e$ hp					
18.5	25	-	42	7.5	10	25	30	34	PSTX30-600-70	1SFA898103R7000	4.6	10.1
25	30	-	52	10	15	30	40	48	PSTX37-600-70	1SFA898104R7000	4.6	10.1
30	37	-	64	15	20	40	50	58	PSTX45-600-70	1SFA898105R7000	4.6	10.1
37	45	-	76	20	25	50	60	72	PSTX60-600-70	1SFA898106R7000	4.6	10.1
55	75	-	105	30	40	75	100	103	PSTX72-600-70	1SFA898107R7000	4.7	10.4
59	80	-	124	30	40	75	100	117	PSTX85-600-70	1SFA898108R7000	4.7	10.4
75	90	-	147	40	50	100	125	138	PSTX105-600-70	1SFA898109R7000	4.7	10.4
90	110	-	181	60	60	150	150	180	PSTX142-600-70	1SFA898110R7000	7.0	15.4
132	160	-	245	75	75	150	200	225	PSTX170-600-70	1SFA898111R7000	8.9	19.6
160	200	-	300	75	100	200	250	292	PSTX210-600-70	1SFA898112R7000	13.3	29.3
184	250	-	360	100	125	250	300	332	PSTX250-600-70	1SFA898113R7000	15.5	34.2
220	295	-	430	150	150	350	450	429	PSTX300-600-70	1SFA898114R7000	15.5	34.2
257	355	-	515	150	200	450	500	523	PSTX370-600-70	1SFA898115R7000	15.5	34.2
355	450	-	640	200	250	500	600	625	PSTX470-600-70	1SFA898116R7000	25.0	55.1
450	600	-	814	250	300	600	700	830	PSTX570-600-70	1SFA898117R7000	27.0	59.5
540	700	-	987	300	350	700	800	1020	PSTX720-600-70	1SFA898118R7000	46.5	102.5
710	880	-	1247	400	500	1000	1200	1240	PSTX840-600-70	1SFA898119R7000	46.5	102.5
800	1000	-	1455	500	600	1200	1500	1450	PSTX1050-600-70	1SFA898120R7000	62.3	137.3
1000	1250	-	1810	600	700	1500	1800	1830	PSTX1250-600-70	1SFA898121R7000	63.3	137.3

Rated operational voltage  $U_e$ , 208...690 V, rated control supply voltage  $U_s$ , 100...250 V AC, 50/60 Hz

IEC rated operational power			current $I_e$ A	UL/CSA rated operational power				FLA	Type	Order code	Net Weight (kg)	Net Weight (lb)
400V $P_e$ kW	500V $P_e$ kW	690V $P_e$ kW		200/208V $P_e$ hp	220/240V $P_e$ hp	440/480V $P_e$ hp	550/600V $P_e$ hp					
18.5	25	37	42	7.5	10	25	30	34	PSTX30-690-70	1SFA898203R7000	4.6	10.1
25	30	45	52	10	15	30	40	48	PSTX37-690-70	1SFA898204R7000	4.6	10.1
30	37	55	64	15	20	40	50	58	PSTX45-690-70	1SFA898205R7000	4.6	10.1
37	45	59	76	20	25	50	60	72	PSTX60-690-70	1SFA898206R7000	4.6	10.1
55	75	90	105	30	40	75	100	103	PSTX72-690-70	1SFA898207R7000	4.7	10.4
59	80	110	124	30	40	75	100	117	PSTX85-690-70	1SFA898208R7000	4.7	10.4
75	90	132	147	40	50	100	125	138	PSTX105-690-70	1SFA898209R7000	4.7	10.4
90	110	160	181	60	60	150	150	180	PSTX142-690-70	1SFA898210R7000	7.0	15.4
132	160	220	245	75	75	150	200	225	PSTX170-690-70	1SFA898211R7000	8.9	19.6
160	200	257	300	75	100	200	250	292	PSTX210-690-70	1SFA898212R7000	13.3	29.3
184	250	315	360	100	125	250	300	332	PSTX250-690-70	1SFA898213R7000	15.5	34.2
220	295	400	430	150	150	350	450	429	PSTX300-690-70	1SFA898214R7000	15.5	34.2
257	355	500	515	150	200	450	500	523	PSTX370-690-70	1SFA898215R7000	15.5	34.2
355	450	600	640	200	250	500	600	625	PSTX470-690-70	1SFA898216R7000	25.0	55.1
450	600	800	814	250	300	600	700	830	PSTX570-690-70	1SFA898217R7000	27.0	59.5
540	700	960	987	300	350	700	800	1020	PSTX720-690-70	1SFA898218R7000	46.5	102.5
710	880	1200	1247	400	500	1000	1200	1240	PSTX840-690-70	1SFA898219R7000	46.5	102.5
800	1000	1400	1455	500	600	1200	1500	1450	PSTX1050-690-70	1SFA898220R7000	62.3	137.3
1000	1250	1700	1810	600	700	1500	1800	1830	PSTX1250-690-70	1SFA898221R7000	63.3	137.3

## PSTX - The advanced range

### Accessories



Cable connectors for CU cables

#### Cable connectors for Cu cables

Article	Wire range mm <sup>2</sup>	Tightening torque max Nm	Type	Order code	Pkg qty	Net kg	lb
PSTX142 ... PSTX170	6-120	8	KIT FC Cu XT4 3pcs	1SDA066917R1	3	0.18	0.40
PSTX142 ... PSTX170	2 x (50-95)	16	LZ185-2C/120	1SFN074709R1000	3	0.30	0.66
PSTX210 ... PSTX370	16-240	25	T5 400 3pcs	1SDA055016R1	3	0.36	0.79
PSTX210 ... PSTX370	2 x (95-185)	22	OZXB4/1	1SCA022194R0890	1	0.19	0.42
PSTX470 ... PSTX570	2 x (120-240)	35	T6 630-S6 6pcs	1SDA013922R1	6	0.57	1.26
PSTX570 ... PSTX1050	3 x (70-185)	45	T6 800-S6 6pcs	1SDA013956R1	6	2.12	4.68



Cable connectors for AL cables

#### Cable connectors for Al cables

Article	Wire range mm <sup>2</sup>	Tightening torque max Nm	Type	Order code	Pkg qty	Net kg	lb
PSTX142 ... PSTX170	95-185	31	KIT FC CuAl T4 3pcs	1SDA054988R1	3	0.14	0.31
PSTX210 ... PSTX370	185-240	43	KIT FC CuAl T5 400 3pcs	1SDA055020R1	3	0.24	0.54
PSTX470 ... PSTX1050	2 x (120-240)	31	KIT FC CuAl T6 630-S6 3pcs	1SDA023380R1	3	0.11	0.24



Terminal extensions

#### Terminal extensions

Article	Dimensions hole ø mm2	bar mm	Type	Order code	Pkg qty	NET kg	lb
PSTX142 ... PSTX170	8.5	17.5 x 5	LX205	1SFN074810R1000	1	0.25	5.55
PSTX210 ... PSTX370	10.5	20 x 5	LX370	1SFN075410R1000	1	0.35	0.77
PSTX470 ... PSTX570	10.5	25 x 5	LX460	1SFN075710R1000	1	0.50	1.10
PSTX720 ... PSTX840	13	40 x 6	LX750	1SFN076110R1000	1	0.85	1.87



Terminal enlargements

#### Terminal enlargements

Article	Dimensions hole ø mm2	bar mm	Type	Order code	Pkg qty	Net kg	lb
PSTX30 ... PSTX105	6.5	15 x 3	LW110	1SFN074307R1000	1	0.07	0.15
PSTX142 ... PSTX170	10.5	17.5 x 5	LW205	1SFN074807R1000	1	0.25	5.55
PSTX210 ... PSTX370	10.5	20 x 5	LW370	1SFN075407R1000	1	0.45	0.99
PSTX470 ... PSTX570	10.5	25 x 5	LW460	1SFN075707R1000	1	0.73	1.61
PSTX720 ... PSTX840	13	40 x 6	LW750	1SFN076107R1000	1	1.23	2.71



Terminal shrouds

#### Terminal shrouds

Article	Description	Type	Order code	Pkg qty	Net kg	lb
PSTX142 ... PSTX170	short for use with cable clamps	LT205-30C	1SFN124801R1000	2	0.05	0.11
PSTX142 ... PSTX170	long for use with compression lugs	LT205-30L	1SFN124803R1000	2	0.22	0.49
PSTX210 ... PSTX370	short for use with cable clamps	LT370-30C	1SFN125401R1000	2	0.04	0.08
PSTX210 ... PSTX370	long for use with compression lugs	LT370-30L	1SFN125403R1000	2	0.28	0.62
PSTX210 ... PSTX370	long and deep for use with extending cable clamps, ATK300/2 and OZXB4	LT370-30D	1SFN125406R1000	2	0.15	0.33
PSTX470 ... PSTX570	short for use with cable clamps	LT460-AC	1SFN125701R1000	2	0.10	0.22
PSTX470 ... PSTX570	long for use with compression lugs	LT460-AL	1SFN125703R1000	2	0.80	1.76
PSTX720 ... PSTX1250	short for use with cable clamps	LT750-AC	1SFN126101R1000	2	0.12	0.27
PSTX720 ... PSTX1250	long for use with compression lugs	LT750-AL	1SFN126103R1000	2	0.83	1.82

## PSTX - The advanced range

### Accessories



USB cable

#### PSTX USB cable

Article	Type	Order code	Pkg qty	Net kg	lb
PSTX USB Cable	PSCA-1	1SFA899314R1001	1	0.05	0.12



Fieldbus plug adaptor

#### Fieldbus plug connection, cable included

Article	Type	Order code	Pkg qty	Net kg	lb
Fieldbus plug adaptor	PS-FBPA	1SFA896312R1002	1	0.05	0.11



I/O module

#### I/O module, 24 V DC digital input

Article	Type	Order code	Pkg qty	Net kg	lb
Extension module for I/O 24 VDC	DX111-FBP.0	1SAJ611000R0101	1	0.22	0.49
Extension module for I/O 110-230 VDC	DX122-FBP.0	1SAJ622000R0101	1	0.22	0.49



- Profibus DP-V1  
- Modbus RTU



DeviceNet



BACnet MS/TP



- BACnet IP  
- EtherCAT  
- EtherNet/IP  
- Modbus TCP  
- Profinet IO

#### Anybus connection accessory for communication protocol suitable for PSTX30 ...PSTX1250

Article	Conection ports	Type	Order code	Pkg qty	kg	lb
Profibus	1	AB-PROFIBUS-1	1SFA899300R1001	1	0.03	0.07
DeviceNet	1	AB-DEVICENET-1	1SFA899300R1002	1	0.03	0.07
Modbus-RTU <sup>1)</sup>	1	AB-MODBUS-RTU-1	1SFA899300R1003	1	0.03	0.07
BACnet IP	2	AB-BACNET-IP-2	1SFA899300R1004	1	0.03	0.07
EtherNet/IP	2	AB-ETHERNET-IP-2	1SFA899300R1006	1	0.03	0.07
Modbus/TCP	2	AB-MODBUS-TCP-2	1SFA899300R1008	1	0.03	0.07
Profinet	2	AB-PROFINET-IO-2	1SFA899300R1010	1	0.03	0.07
BACnet MS/TP	1	AB-BACNET-MSTP-1	1SFA899300R1011	1	0.03	0.07
EtherCAT	2	AB-ETHERCAT-IP-2	1SFA899300R1012	1	0.03	0.07
New CANopen	1	AB-CANopen-IO-1	1SFA899300R1013	1	0.03	0.07

<sup>1)</sup> only needed when Com 3-port is used with Extension I/O

## PSTX - The advanced range

### Technical data

Technical data	PSTX30... 1250
Rated insulation voltage $U_i$	690V
Rated operational voltage $U_e$	208...600 V, 208...690V +10% / -15%, 50/60Hz $\pm$ 10%
Rated control supply voltage $U_s$	100...250 V +10%/-15%, 50/60Hz $\pm$ 10%
Rated control circuit voltage $U_c$	Internal or external 24 V DC
Starting capacity at $I_e$	4 x $I_e$ for 10 sec
Number of starts per hour	10 for PSTX30 ... PSTX370 <sup>1)</sup> 6 for PSTX470 ... PSTX1250 <sup>1)</sup>
Overload capability	Overload class 10
Maximum altitude	4000 m (13123 ft) <sup>3)</sup>
<b>Ambient temperature</b>	
During operation	-25...+60 °C, (-13...+140 F) <sup>2)</sup>
During storage	-40...+70 °C, (-40...+158 F)
<b>Degree of protection</b>	
Main circuit	-
Supply and control circuit	IP20
<b>Main circuit</b>	
Built-in bypass contactor	Yes
Cooling system - Fan cooled	Yes (thermostat controlled)
<b>HMI for settings (Human Machine Interface)</b>	
Display	LCD type, graphical
Languages	Arabic, Chinese, Czech, Dutch, English, Finnish, French, German, Greek, Indonesian, Italian, Polish, Portuguese, Russian, Spanish, Swedish and Turkish
Keypad	2 selection keys, 4 navigation keys, start key, stop key, info key and remote/local key
<b>Signal relays</b>	
Number of programmable signal relays	3 (each relay can be programmed to None, Run, Top of ramp, Event group 0-6, Sequence 1-3 Run, Sequence 1-3 Top of ramp or Run reverse)
K4	Default as Run signal
K5	Default as Top of Ramp (Bypass) signal
K6	Default as Event group 0 (Faults)
Rated operational voltage, $U_e$	250 V AC/24 V DC
Rated thermal current $I_{th}$	5 A
Rated operational current $I_e$ at AC-15 ( $U_e=250$ V)	1.5 A
<b>Analog output</b>	
Output signal reference	0...10 V, 0...10 mA, 0...20 mA, 4...20 mA
Type of output signal	Motor current (A), Main voltage (V), Active power (kW), Active power (HP), Reactive power (kVAR), Apparant power (kVArh), Active energy (kWh), Reactive energy (kVArh), cos phi, Motor temperature (%), Thyristor temperature (%), Motor voltage (%), Main frequency (Hz), PT100 temperature (centigrade), PTC resistance (Ohm)

<b>Control circuit</b>	
Number of inputs	2 (start, stop)
Number of additional programmable inputs	3 (each input can be programmed to: None, Reset, Enable, Slow speed forward (Jog), Slow speed reverse (Jog), Motor heating, Stand still brake, Start reverse, User defined protection, Emergency mode (active high), Emergency mode (active low), Fieldbus disable control, Start 1, Start 2, Start 3, Switch to remote control or Cancel brake)
<b>Signalling indication LED</b>	
Ready	Green
Run	Green
Fault	Red
Protection	Yellow
<b>External keypad</b>	
Detachable keypad	Yes
Display	LCD type, graphical
Ambient temperature	
During operation	-25...+60 °C, (-13...+140 F)
During storage	-40...+70 °C, (-40...+158 F)
Degree of protection	IP66 (Type 1, 4X, 12)
<b>Start and stop functions</b>	
Soft start with voltage ramp	Linear voltage ramp, suitable for most applications
Soft stop with voltage ramp	Used to prolong the stop sequence
Soft start with torque control	Linear torque ramp, the best way to start pumps
Soft stop with torque control	Commonly used to reduce water hammering in pumps
Kick start	More power in the start for heavy duty applications.
Full voltage start	0.5 second start ramp for applications with need of high starting torque
Sequence start	Start multiple motors with one softstarter
Current limit	Limits the current below a specified value
Dual current limit	Consist of a low level, a high level and a time between them
Current limit ramp	A linear increase of the current from the low to the high level
Torque limit	Limit the torque to between 20-200%
Pre-start function	Use Motor heating, Stand still brake or Jog automatically prior to start ramp
Jog with slow speed, forward and reverse	Run the motor in three different speeds, both forward and reverse
Start reverse (external contactors)	Internal logic that allows control of external contactors for reverse start
Dynamic brake	Provides a braking force to decrease stop time

<sup>1)</sup> Valid for normal start (class 10) for 50% on time and 50% off time. If other data is required, contact your local ABB office.

<sup>2)</sup> Above 40 °C (104 F) up to max. 60 °C (140 F) reduce the rated current with 0.8% per °C (0.44% per F).

<sup>3)</sup> When used at high altitudes, above 1000 meters (3281 ft) up to 4000 meters (13123 ft), de-rate the rated current using the following formula.

$[\% \text{ of } I_e = 100 - x \cdot 1000] \cdot x = \text{actual altitude of the softstarter in meter, } [\% \text{ of } I_e = 100 - x \cdot 3280] \cdot x = \text{actual altitude of the softstarter in feet. For de-rating of voltage, contact your local ABB office. 150}$

## PSTX - The advanced range

### Technical data

<b>Fieldbus connection</b>	
Built-in Modbus RTU	Yes, with RS485 interface on terminals 23 and 24
Connection for Anybus	Yes, including most common protocols, see catalog for details
Connection for ABB Fieldbus plug	Yes, compatible with a special adapter, see catalog for details
<b>Protections</b>	
Electronic overload protection, EOL	User defined, class 10A, 10, 20, 30
Dual overload (separate overload for start and run)	Possible to set separate overloads for start and full speed
PTC connection	User defined temperature control with external PTC sensor
PT-100 connection	User defined temperature control with external PT-100 sensor
Locked rotor protection	Prevents start if motor is stuck, e.g. stuck pumps and conveyors
Current underload protection	Stops the process if the load is too light, e.g. a pump running dry
Current imbalance protection	User defined, checks current imbalance between the phases
Power factor underload protection	User defined, trip if power factor is out of range
Under voltage protection	User defined, prevents the motor from stalling in weak networks
Over voltage protection	User defined, prevents the motor from damage at high voltage levels
Voltage imbalance protection	User defined, checks voltage imbalance between the phases
Earth fault protection / ground fault protection	User defined, 0.1-1.0 sec, stops the process if earth fault is detected
Phase reversal protection	Prevents start if phases are connected in the wrong order
Bypass open protection	Trips if the bypass is open when it should be closed
User defined protection	Programmable input, can be used with external protection device
Too long current limit protection	User defined, trips when the current has been at the current limit for too long time
HMI failure protection	Indicates communication failure between softstarter and HMI
Fieldbus failure protection	Indicates communication failure between softstarter and PLC
Extension IO failure protection	Indicates communication failure between softstarter and IO module
Max number of starts/hour	Prevents start if the thyristors gets too warm (thus used over specification)
Too long start time protection	User defined, trips when the starting time exceeds a set value
<b>External faults detection</b>	
Phase loss	Yes
High current	Yes
Low control supply voltage	Yes
Faulty usage	Yes, e.g. using limp mode inside-delta
Faulty connection	Yes
Bad network quality	Yes
<b>Vibration test</b>	
According to IEC 60068-2-6:2007	

<b>Warnings</b>	
Current underload warning	User defined on/off
Current imbalance warning	User defined on/off
Voltage imbalance warning	User defined on/off
Thyristor overload warning (SCR)	User defined on/off
Electronic overload Time-to-trip	User defined on/off
Short circuit warning (for Limp mode)	User defined on/off, for Limp mode
Over voltage warning	User defined on/off
Under voltage warning	User defined on/off
Power factor underload warning	User defined on/off
Locked rotor warning	User defined on/off
Faulty fan warning	User defined on/off
THD(U) - Total Harmonic Distortion warning	User defined on/off
Motor runtime limit warning	User defined on/off
Phase loss warning (for stand by)	User defined on/off, for stand by
EOL warning	User defined on/off
<b>Internal faults detection</b>	
Thyristor overload	Yes
Short circuit	Yes
Open circuit thyristor or gate	Yes
Heat sink over temperature	Yes
Shunt fault	Yes
<b>PTC input</b>	
Switch off resistance	2825 ohm ± 20%
Switch on resistance	1200 ohm ± 20%
<b>Other functions</b>	
Real time clock	Can maintain time when the softstarter isn't powered up, 48 h back-up
Event log	Log of events such as trips, parameters changed and operation
Emergency mode	To keep the softstarter running regardless of trip or failure. Activated via DI
Automatic restart	In case of trip and stopped motor, the softstarter can restart itself
Keypad password	Lock the keypad to inhibit unauthorized motor control
Pump cleaning	Can reverse pump flow and clean out pipes
Electronic overload Time-to-cool	Time until the motor is ready to be restarted after an EOL trip
Thyristor runtime measurement	Measures most electrical variables, e.g. voltage, current and power
Auto phase sequence detection	Detection of the phase sequence
Electricity metering	Measures most electrical variables, e.g. voltage, current and power
Motor heating	DC injection in all windings to heat up the motor. Useful in cold or humid environment
Stand still brake	Prevents the motor from moving, useful to keep fans from reversing
Voltage sags detection	User defined
Limp mode with two-phase motor control if one set of thyristors is shorted	Can keep process running until planned maintenance

For all functions and features see installation and commissioning manual, available on [solutions.abb/softstarters](https://www.abb.com/solutions/softstarters)



## PSTX - The advanced range

### Technical data

#### Fuse ratings and power losses

Softstarter	Current range	Max power loss at rated $I_e$	Max fuse rating - main circuit <sup>1) 2)</sup> Bussmann fuses, DIN43 620 (Knife)			Power requirements supply circuit Holding (VA) / Pull-in (VA)
	A	W	A	Type	Size	
PSTX30	9.0...30.0	0.8	100	170M1567	000	49/51
PSTX37	11.1...37.0	1.2	125	170M1568	000	49/51
PSTX45	13.5...45.0	1.8	160	170M1569	000	49/51
PSTX60	18.0...60.0	3.2	160	170M1569	000	49/51
PSTX72	21.6...72.0	4.7	250	170M1571	000	49/51
PSTX85	22.5...85.0	6.5	315	170M1572	000	49/51
PSTX105	31.8...106.0	10	400	170M3819	1*	49/51
PSTX142	42.9...143.0	18	500	170M5810	2	49/53
PSTX170	51.3...171.0	26	630	170M5812	2	49/53
PSTX210	63.0...210.0	48	630	170M5812	2	56/276
PSTX250	75.0...250.0	68	700	170M5813	2	56/276
PSTX300	90.0...300.0	97	800	170M6812	3	56/276
PSTX370	111.0...370.0	148	900	170M6813	3	56/276
PSTX470	141.0...470.0	99	900	170M6813	3	67/434
PSTX570	171.0...570.0	146	1000	170M6814	3	67/434
PSTX720	216.0...720.0	78	1250	170M8554	3	61/929
PSTX840	252.0...840.0	106	1500	170M6018	3	61/929
PSTX1050 <sup>3)</sup>	315.0...1050.0	165	1800	170M6020	3	68/929
PSTX1250 <sup>3) 4)</sup>	375.0...1250.0	234	2000	170M6021	3	68/929

<sup>1)</sup> For the supply circuit 6 A delayed, for MCB use C characteristics.

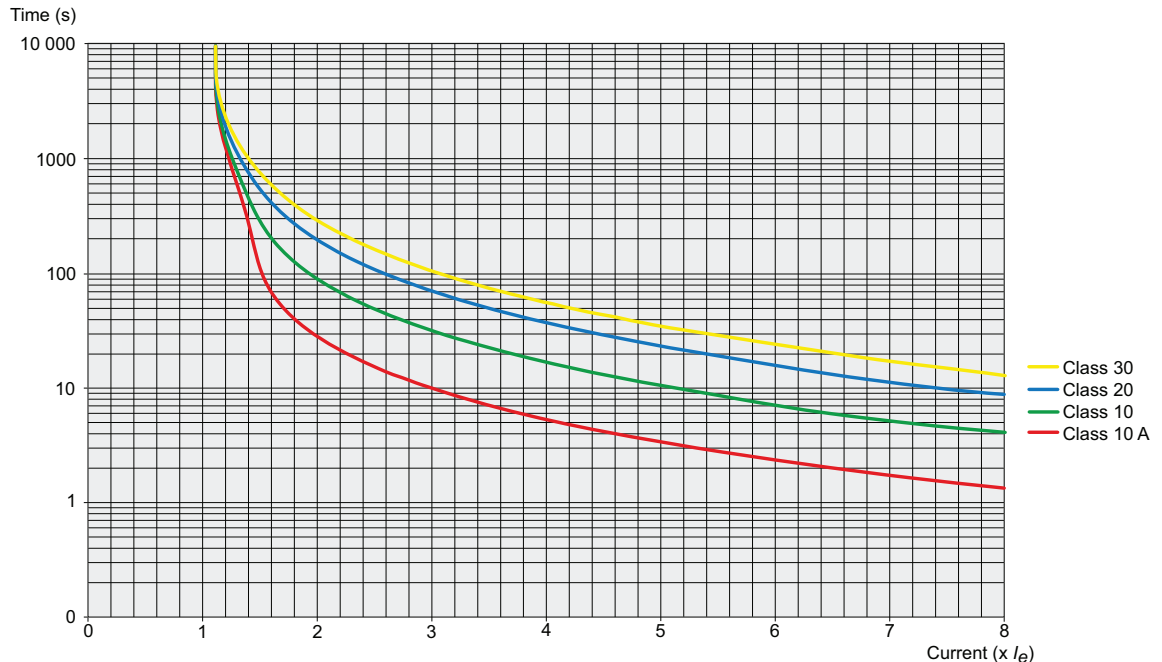
<sup>2)</sup> For inside delta connection the fuses shall be placed inside the delta. Contact ABB for more information.

<sup>3)</sup> 170M6019 with fuse rating 1600 A should be used for 690 V version.

<sup>4)</sup> For 690 V version, Bussmann fuses are only available for motors with rated current up to 1150 A.

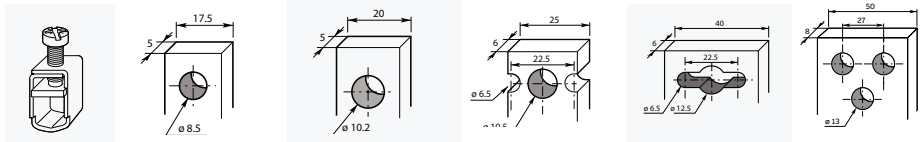
#### Tripping curves for electronic overload protection (cold) for PSE and PSTX

Tripping curves for the integrated electronic overload protection. All units have an integrated electronic overload protection that can be set to four different tripping classes. Below you find a curve for each tripping class in cold state. These tripping curves are valid for PSTX.



## PSTX - The advanced range

### Technical data



Main terminals						
Article	PSTX30 ... PSTX105	PSTX142 ... PSTX170	PSTX210 ... PSTX370	PSTX470 ... PSTX570	PSTX720 ... PSTX1050	PSTX1250
<b>Cu cable - flexible 1 x mm<sup>2</sup></b>	10...70 mm <sup>2</sup>	6...120 mm <sup>2</sup>	16...240 mm <sup>2</sup>	-	-	-
Clamp type	Included	1SDA066917R1	1SDA055016R1	-	-	-
Tightening torque	8 Nm	14 Nm	25 Nm	-	-	-
<b>Cu cable - flexible 2 x mm<sup>2</sup></b>	6...35 mm <sup>2</sup>	50...95 mm <sup>2</sup>	70...185 mm <sup>2</sup>	-	-	-
Clamp type	Included	LZ185-2C/120 1SFN074709R1000	OZXB4 <sup>1)</sup> 1SCA022194R0890	-	-	-
Tightening torque	8 Nm	16 Nm	22 Nm	-	-	-
<b>Cu cable - Stranded 1 x mm<sup>2</sup></b>	10...95 mm <sup>2</sup>	6...150 mm <sup>2</sup>	16...300 mm <sup>2</sup>	-	-	-
Clamp type	Included	1SDA066917R1	1SDA055016R1	-	-	-
Tightening torque	8 Nm	14 Nm	25 Nm	-	-	-
<b>Cu cable - Stranded 2 x mm<sup>2</sup></b>	6...35 mm <sup>2</sup>	50...120 mm <sup>2</sup>	70...185 mm <sup>2</sup>	120...240 mm <sup>2</sup>	-	-
Clamp type	Included	LZ185 - 2C/120 1SFN074709R1000	OZXB4 <sup>1)</sup> 1SCA022194R0890	1SDA013922R1	-	-
Tightening torque	8 Nm	16 Nm	22 Nm	35 Nm	-	-
<b>Cu cable - Stranded 3 x mm<sup>2</sup></b>	-	-	-	-	70...185 mm <sup>2</sup>	-
Clamp type	-	-	-	-	1SDA013956R1	-
Tightening torque	-	-	-	-	45 Nm	-
<b>Al cable - Stranded 1 x mm<sup>2</sup></b>	-	95...185 mm <sup>2</sup>	185...240 mm <sup>2</sup>	-	-	-
Clamp type	-	1SDA0549881R1	1SDA055020R1	-	-	-
Tightening torque	-	31 Nm	43 Nm	-	-	-
<b>Al cable - Stranded 2 x mm<sup>2</sup></b>	-	-	-	120...240 mm <sup>2</sup>	-	-
Clamp type	-	-	-	1SDA023380R1	-	-
Tightening torque	-	-	-	31 Nm	-	-
<b>Lugs Width ≤</b>	-	24 mm (0.945 in)	32 mm (1.260 in)	47 mm (1.850 in)	50 mm (1.969 in)	50 mm (1.969 in)
Diameter >=	-	8 mm (0.355 in)	10.2 mm (0.402 in)	10.5 mm (0.413 in)	12.5 mm (0.492 in)	13 mm (0.519 in)
Tightening torque	-	18 Nm (160 in lb)	28 Nm (248 in lb)	35 Nm (310 in lb)	45 Nm (398 in lb)	45 Nm (398 in lb)
<b>Connection capacity acc to UL / CSA 1 x AWG / kcmil</b>	6...2/0	6...300 kcmil	4...400 kcmil	-	-	-
Clamp type	Included	ATK185	ATK300	-	-	-
Tightening torque	71 in lb	300 in lb	375 in lb	-	-	-
<b>Connection capacity acc to UL / CSA 2 x AWG / kcmil</b>	-	-	4...500 kcmil	2/0...500 kcmil	2/0...500 kcmil	-
Clamp type	-	-	ATK300/2 <sup>2)</sup>	ATK580/2	ATK580/2	-
Tightening torque	-	-	375 in lb	375 in lb	375 in lb	-
<b>Connection capacity acc to UL / CSA 3 x AWG / kcmil</b>	-	-	-	2/0...500 kcmil	2/0...500 kcmil	-
Clamp type	-	-	-	ATK750/3	ATK750/3	-
Tightening torque	-	-	-	375 in lb	375 in lb	-
<b>Supply and control circuit</b>						
Cu cable - Stranded 1 x mm <sup>2</sup>	0.75...2.5 mm <sup>2</sup> (19...14 AWG)					
Cu cable - Stranded 2 x mm <sup>2</sup>	0.75...1.5 mm <sup>2</sup> (19...16 AWG)					
Tightening torque	0.5 Nm (4.4 in lb)					

<sup>1)</sup> Terminal shrouds 1SFN125406R1000 must be used.

<sup>2)</sup> Terminal shrouds 1SFN125406R1000 can be used.

#### PSTX integrated bypass ratings

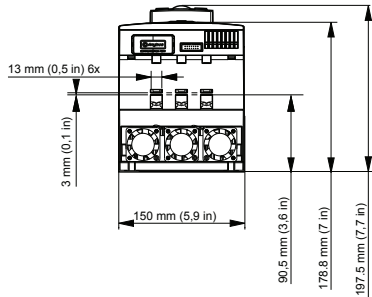
All ABB's softstarters are equipped with a built-in bypass contactor. This bypass contactor is rated AC-1 since it only make and break the motor in full speed at the rated current of the softstarter. However, in the PSTX470-PSTX1050 products, the bypass contactors has also a lower rated AC-3 rating which is shown in the table below.

Softstarter	PSTX470... PSTX570	PSTX720... PSTX1050	PSTX1250
<b>Integrated contactor</b>	<b>AF370</b>	<b>AF750</b>	<b>AF1250</b>
AC-3 rating at 400 V	370 A	750 A	-
IEC AC-3 Rated operational power at 400 V	200 kW	400 kW	-
UL/CSA 3-phase motor rating at 480 V	300 hp	600 hp	-

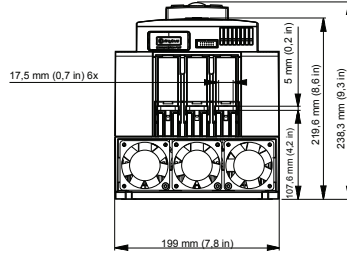
# PSTX - The advanced range

## Dimensions

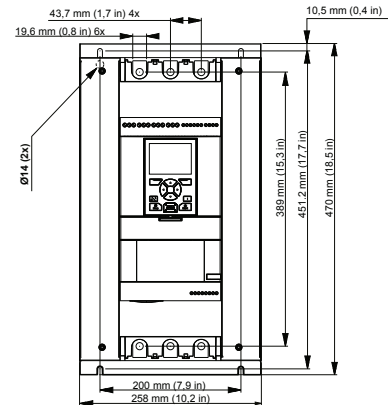
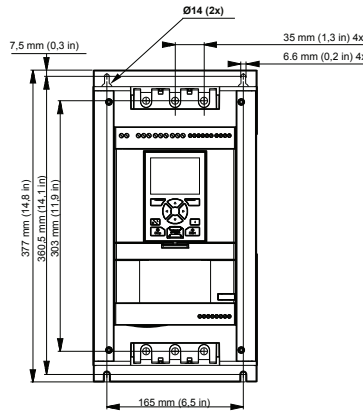
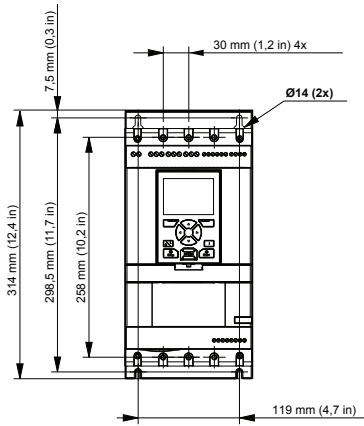
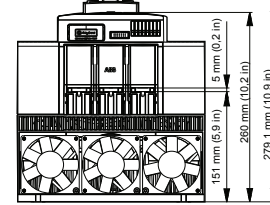
PSTX30... 105



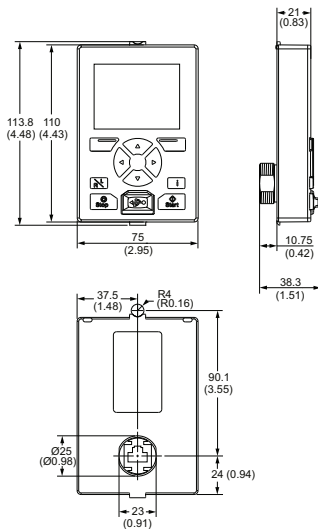
PSTX142... 170



PSTX210... 370



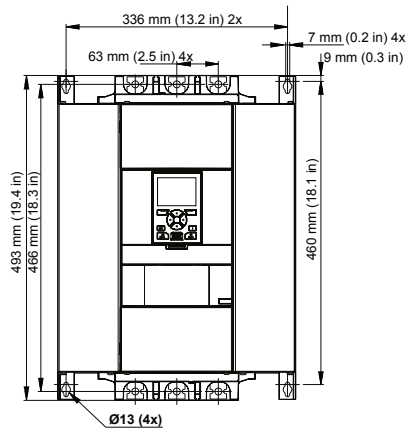
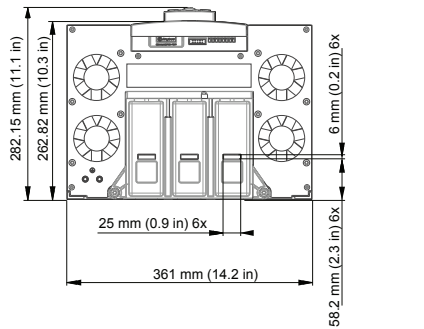
PSTX detachable keypad



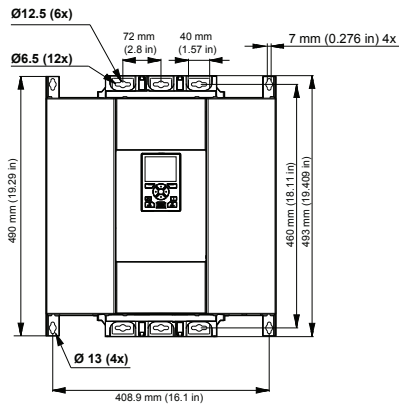
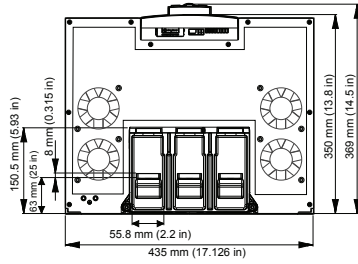
# PSTX - The advanced range

## Dimensions

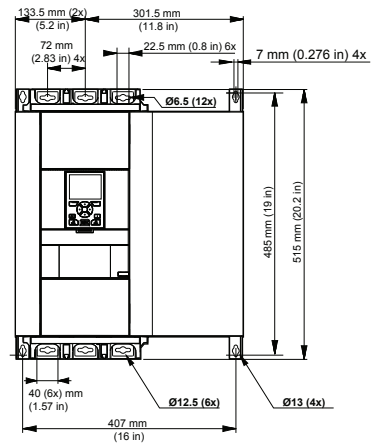
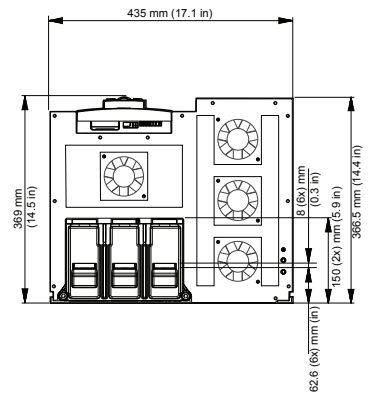
**PSTX470... 570**



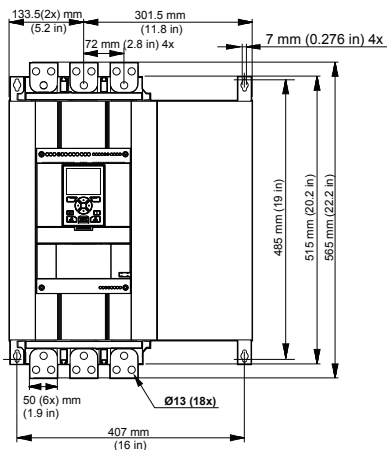
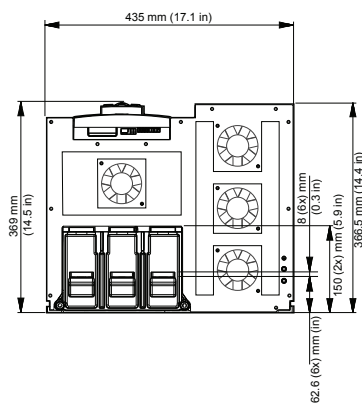
**PSTX720... 840**



**PSTX1050**



**PSTX1250**



# PSTX - The advanced range

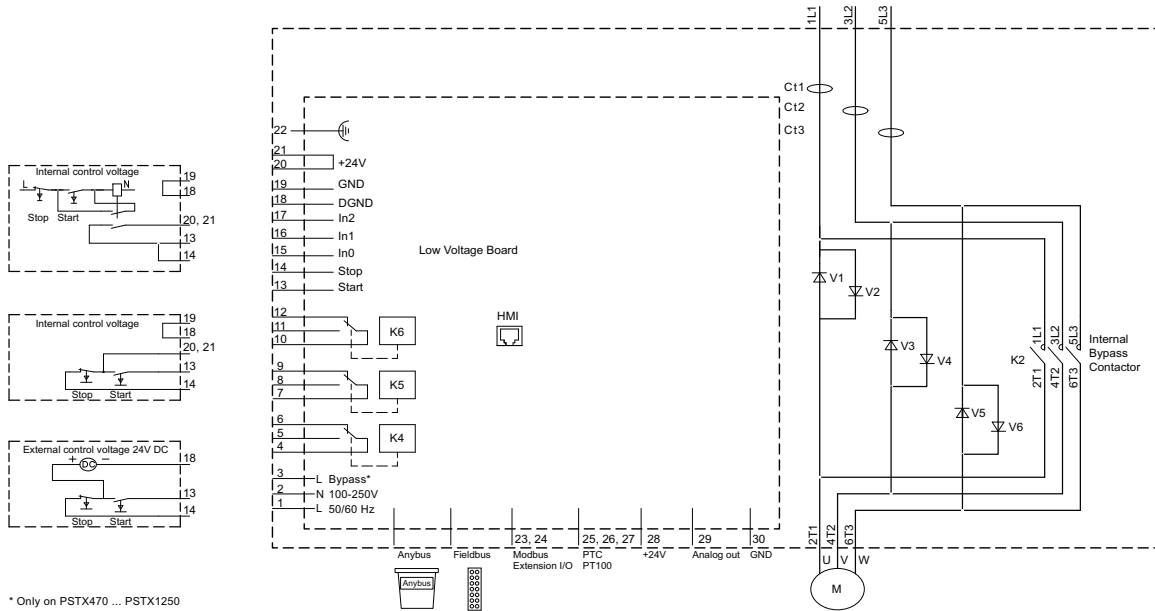
## Circuit diagrams



### CAUTION

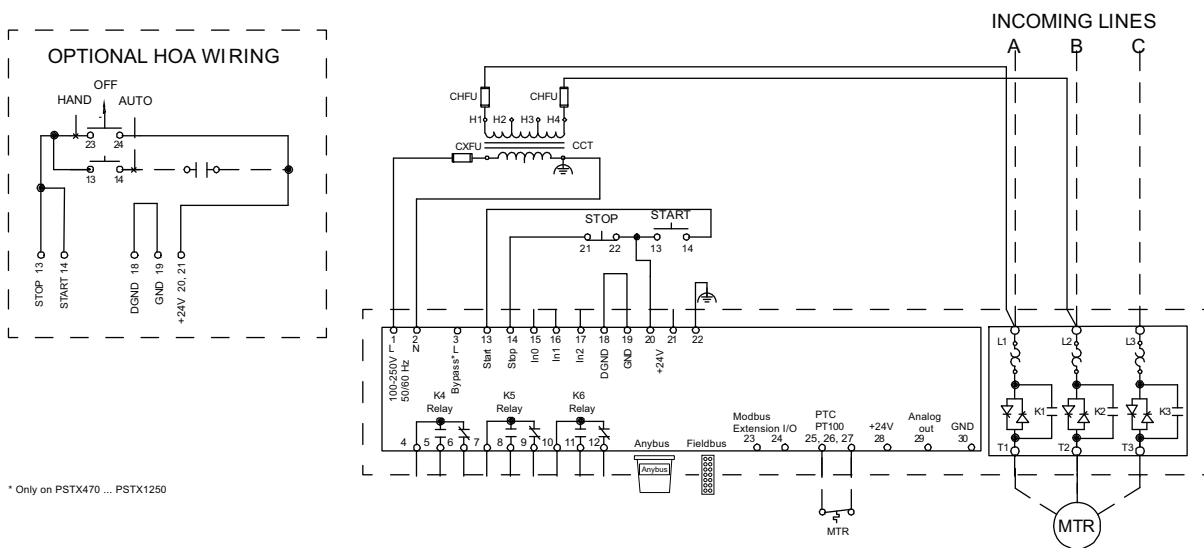
Terminal 22 is a function earth, it is not a protective earth. It shall be connected to the mounting plate.

PSTX30 ... PSTX1250 IEC circuit diagram



\* Only on PSTX470 ... PSTX1250

PSTX30 ... PSTX1250 UL circuit diagram



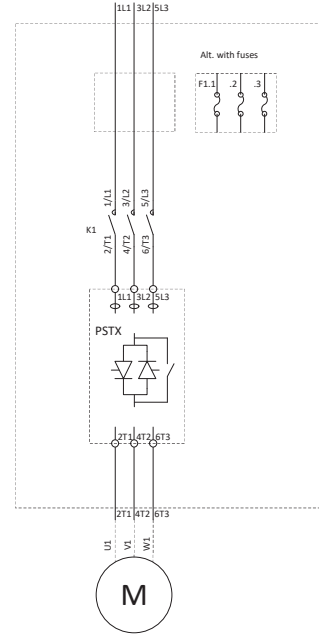
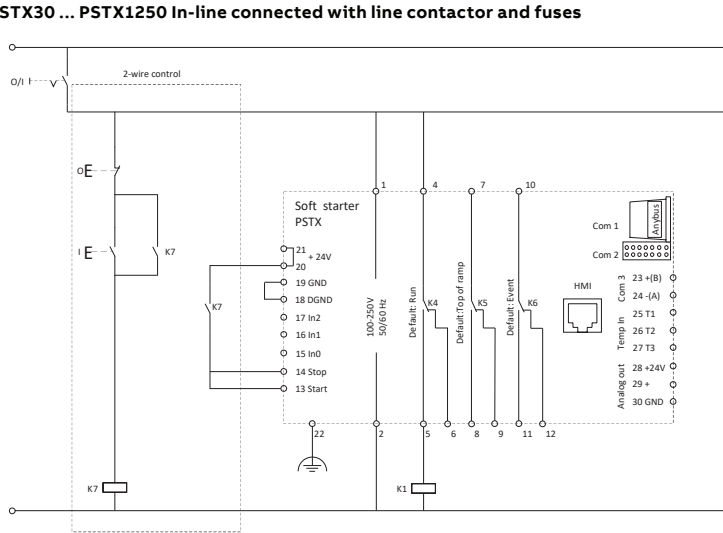
\* Only on PSTX470 ... PSTX1250

For more circuit diagrams see [solutions.abb.com/softstarters](http://solutions.abb.com/softstarters)

# PSTX - The advanced range

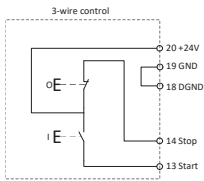
## Circuit diagrams

### PSTX30 ... PSTX1250 In-line connected with line contactor and fuses

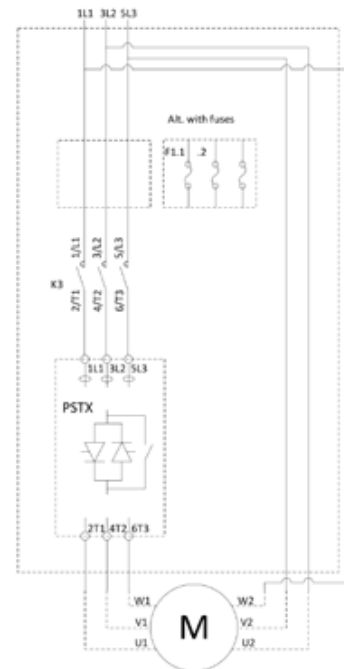
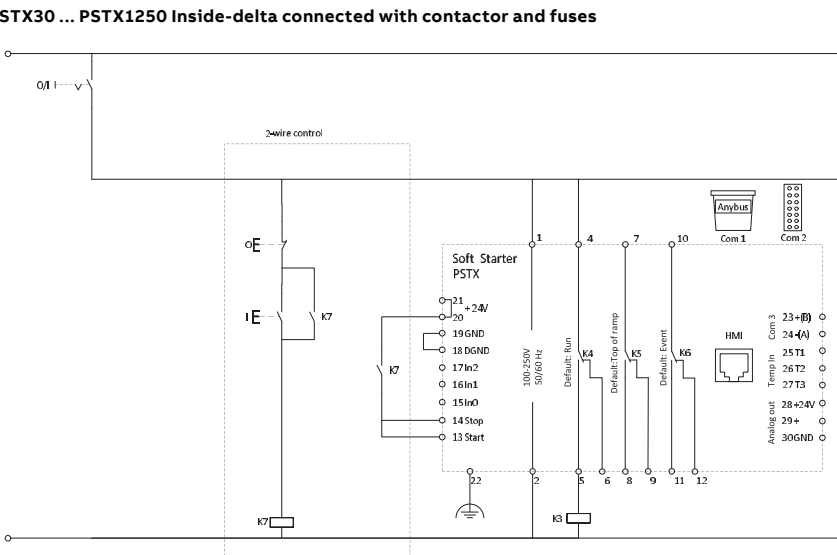


Coil consumption for main contactors.  
 Pull-in max 15A  
 Holding max 1.5A

If the pull-in or holding values are higher, the main contactors must be controlled via an auxiliary contactor.

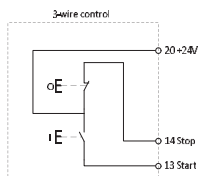


### PSTX30 ... PSTX1250 Inside-delta connected with contactor and fuses



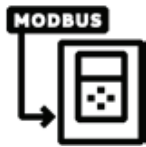
Coil consumption for Inside Delta contactor.  
 Pull-in max 15A  
 Holding max 1,5A

If the pull-in or holding values are Higher, the Inside Delta contactor must be controlled via an auxiliary contactor.



# Fieldbus communication

## For softstarters



### Fieldbus communication interface offering

PSR, PSE and PSTX softstarters can be connected to a fieldbus network for monitoring and control. All major industrial fieldbus protocols are covered with different accessories making the installation very flexible.

### Built-in Modbus-RTU for PSTX and PSE

- Built-in Modbus RTU communication interface
- Easy to install using the Modbus RTU adaptor which is included with the Softstarter
- Through this communication interface it is possible to get full control and status information of the Softstarter as well as reading- and writing parameters

### Anybus connection for PSTX

- Anybus connection accessory for communication protocol suitable for PSTX30... PSTX1250



PROFIBUS



DeviceNet



Modbus RTU



BACnet IP



EtherNet IP



Modbus TCP



PROFINET



BACnet MS/TP



EtherCAT



CANopen

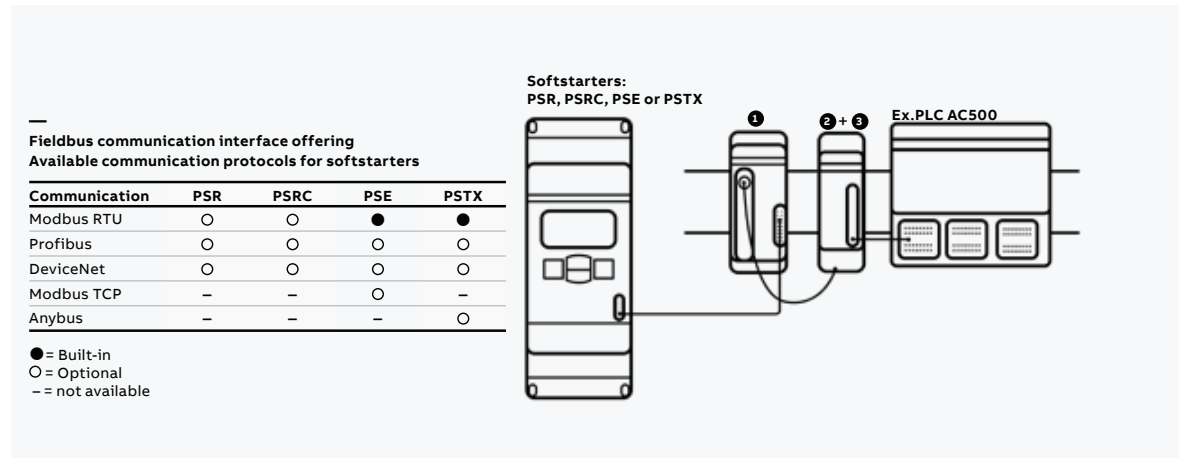
### Anybus connection accessory for communication protocol suitable for PSTX30 ...PSTX1250

Article	Connection ports	Type	Order code	Pkg qty	kg	lb
Profibus	1	AB-PROFIBUS-1	1SFA899300R1001	1	0.03	0.07
DeviceNet	1	AB-DEVICENET-1	1SFA899300R1002	1	0.03	0.07
Modbus-RTU <sup>1)</sup>	1	AB-MODBUS-RTU-1	1SFA899300R1003	1	0.03	0.07
BACnet IP	2	AB-BACNET-IP-2	1SFA899300R1004	1	0.03	0.07
EtherNet/IP	2	AB-ETHERNET-IP-2	1SFA899300R1006	1	0.03	0.07
Modbus/TCP	2	AB-MODBUS-TCP-2	1SFA899300R1008	1	0.03	0.07
Profinet	2	AB-PROFINET-IO-2	1SFA899300R1010	1	0.03	0.07
BACnet MS/TP	1	AB-BACNET-MSTP-1	1SFA899300R1011	1	0.03	0.07
EtherCAT	2	AB-ETHERCAT-IP-2	1SFA899300R1012	1	0.03	0.07
New CANopen	1	AB-CANopen-IO-1	1SFA899300R1013	1	0.03	0.07

<sup>1)</sup> only needed when Com 3-port is used with Extension I/O

# ABB Fieldbus interface

## For softstarters



Fieldbus plug adapter

### 1 Fieldbus plug adapter with cable

Article	Type	Order code	Pkg qty	kg	lb
Fieldbus plug adapter	PS-FBPA	1SFA896312R1002	1	0.05	0.11



Fieldbus plug kit

### 2 Fieldbus plug kit for mounting fieldbus plug adapter together with fieldbus plugs

Includes: Holder, cable, cable holder and 2 terminal blocks

Article	Type	Order code	Pkg qty	kg	lb
Accessory kit	PS-FBPK	1SFA899320R1002	1	0.15	0.33

- Profibus  
- DeviceNET

### 3 Fieldbus communication interface

Article	Type	Order code	Pkg qty	kg	lb
<b>Profibus</b>					
Profibus DP communication interface	PDP32.0	1SAJ242000R0001	1	0.05	0.11
Cable from PDP32.0 to drawer outside, length 1.5 m	CDP24.150	1SAJ929240R0015	1	0.06	0.13
<b>DeviceNet</b>					
DeviceNet communication interface; terminal block for fieldbus connection included	DNP31.0	1SAJ231000R0001	1	0.04	0.09
Cable from DNP31.0 to drawer outside, length 1.5 m	CDP24.150	1SAJ929240R0015	1	0.06	0.13
<b>Modbus-TCP <sup>1)</sup></b>					
Ethernet Modbus TCP interface	MTQ22-FBP	1SAJ260000R0100	1	0.17	0.38
Cable ETH-X1/X4-M12 female, length 1.5m	CDP17-FBP.150	1SAJ929170R0015	1	0.08	0.17
<b>Modbus-RTU <sup>2)</sup></b>					
Modbus RTU communication interface; terminal block for fieldbus connection included	MRP31.0	1SAJ251000R0001	1	0.04	0.09
Cable from MRP31.0 to drawer outside, length 1.5 m	CDP24.150	1SAJ929240R0015	1	0.06	0.13



Modbus-TCP

<sup>1)</sup> only for PSE softstarter no fieldbus plug kit needed

<sup>2)</sup> Only for PSR, Modbus RTU is built-in on PSE and PSTX.

Note: See separate catalog for fieldbus communication interfaces: [Link](#)  
For more information visit the Universal Motor Controller website: [Link](#)



# Marketing materials and tools

It is easy to access more information about ABB softstarters online. On our web page you will find tools for selection, coordination tables, CAD drawings and different types of documentation. [solutions.abb.com/softstarters](https://solutions.abb.com/softstarters)



## Marketing materials

### Panorama >

Softstarter product overview.

### Leaflets >

One- or two pages information for example case studies, fact sheet and more.

### Manuals >

Do you need help with settings or communication and more check out our softstarter manuals.

### Certificates >

ISO certificates and approvals for softstarters.

### Videos >

Softstarter YouTube playlist.



—  
PSTX105-600-70D  
Box with accessories  
1SFA898109R7008

## Demo units

Article	Description	Order code
PSR16-600-70D	Demonstration unit without power electronics	1SFA896107R7009
PSR30-600-70D	Demonstration unit without power electronics	1SFA896109R7009
PSR45-600-70D	Demonstration unit without power electronics	1SFA896111R7009
PSR105-600-70D	Demonstration unit without power electronics	1SFA896115R7009
PSE105-600-70D	Demonstration unit without power electronics	1SFA897109R7009
PSTX105-600-70D	Demonstration unit without power electronics packed in a case with pushbuttons and USB cable	1SFA898109R7008
PSTX105-600-70D	Demonstration unit without power electronics	1SFA898109R7009
PSTX170-600-70D	Demonstration unit without power electronics	1SFA898111R7009
PSTX370-600-70D	Demonstration unit without power electronics	1SFA898115R7009

## Extended warranty

### Extended lifetime

Time to use your processes to their full potential. For Softstarters we have extended warranty options up to 3 years. Professional commissioning with warranty extension provides free of charge rapid response services, if the unexpected occurs.

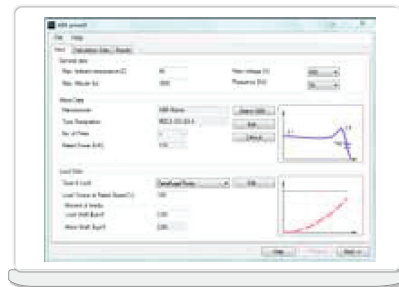
[Extended warranty tool >](#)



### PSTX simulator

Software application for testing and learning more about PSTX softstarter. Simulate a motorstart in your computer an easy way to learn the menu and parameters.

[PSTX Simulator >](#)



### ABB proSoft

Our popular software for the best softstarter/application match, which is free to download and use. All relevant ABB motors are preset in the tool, and all other motors can be set manually.

[ABB proSoft >](#)



### SoftstarterCare™

Service engineer tool makes softstarter commissioning easy by plug-in your PSE or PSTX softstarter using a PC. Access all parameters, event logs and troubleshooting information.

[SoftstarterCare™ >](#)



### ABB e-configure

Product and application configuration tool for fast and easy online selection of softstarters.

[ABB e-Configure >](#)



# Notes

Large blank area for notes, consisting of numerous horizontal lines. The lines are evenly spaced and cover the majority of the page below the 'Notes' heading.

—  
For more information, please contact  
your local ABB representative or visit  
**[solutions.abb/softstarters](https://solutions.abb/softstarters)**



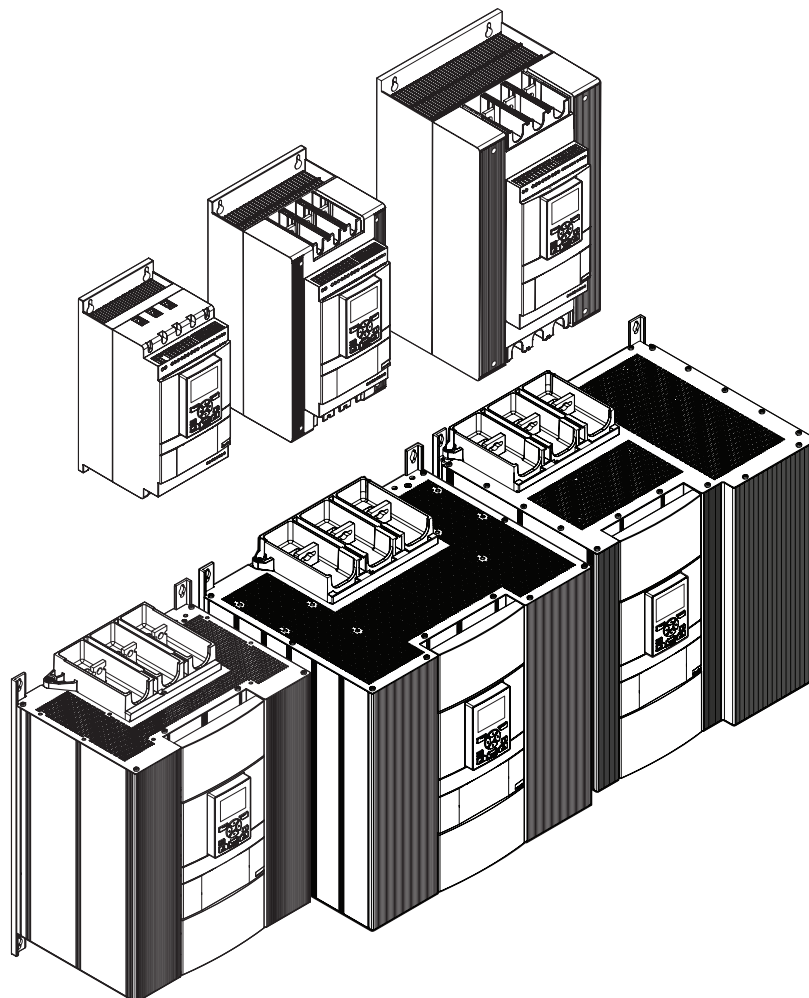
To get more information,  
install QR code reader on  
your mobile device, scan the  
code and see more.

---

1SFC132082M9901

# Softstarters Type PSTX30...PSTX1250


## User Manual short form



CE according to EN /IEC 60947-4-2

This manual belongs to:

---

English EN	ABB softstarter PSTX30...PSTX1250 operating instructions Graphics 	Page 4 Page 244
	Graphics	244



# 1 Read this first

Thank you for selecting this ABB PSTX softstarter. Read carefully and make sure you understand all instructions before you mount, connect and configure the softstarter.

This manual is a short form manual intended for quick and easy installation of the PSTX softstarter. For complete information, see 1SFC132081M0201 - Softstarters Type PSTX30...PSTX1250, Installation and Commissioning Manual available on: <https://solutions.abb/softstarters>

- The softstarter shall be installed by authorized personnel only.
- ABB personnel must obey the ABB CISE 15.4 instructions.
- This manual is a part of the PSTX softstarter and must always be available to personnel that works with this material.
- Always read the full manual before you use the softstarter.

In the User Manual, these symbols are used:



The **caution** symbol in the left margin: if you don't obey this instruction there is a risk for personal injury.



The **warning** symbol in the left margin: if you don't obey this instruction there is a risk for damage to equipment or property



The **information** symbol in the left margin: tells the reader about relevant facts and conditions



The **graphics** symbol in the right margin: refers to graphical information.



Approved personnel are allowed to install and make the electrical connection of the softstarter in accordance with existing laws and regulations.



Examine the softstarter and the package when you unpack your new PSTX softstarter. If there are damages, please speak to the transportation company or the ABB reseller/office immediately.



Only approved personnel are allowed to do service and repair.  
Note: not approved repair can effect the warranty.

Modifications to data in this manual can be applied without notice.



## 2 Description



The PSTX softstarter has the latest technology for soft starting and soft stopping of standard squirrel cage motors.

General data	Description
Rated insulation voltage, $U_i$	600 V / 690 V
Rated operational voltage, $U_e$	208-600 / 690 V, 50 / 60 Hz
Rated control supply voltage, $U_s$	100-250 V, 50 / 60 Hz
Voltage tolerance	+10% to -15%
Frequency tolerance	$\pm 10\%$
Rated impulse withstand voltage	6 kV operational circuit / 4 kV control supply circuit
Inputs	Start, stop, 3 programmable inputs, temperature sensor input
24 V output	24 V DC $\pm 5\%$ Max 250 mA
Analog output	4-20 mA, 0-20 mA, 0-10 V, 0-10 mA
Relay outputs	3 programmable
Communication	3 Fieldbus ports, Extension I/O
EMC	IEC 60947-4-2 Class A <b>1</b>
Recommended fuse Control supply circuit	6 A Delayed MCB use C characteristics
Pollution degree	3



**1** This product has been designed for environment A. Use of this product in environment B may cause unwanted electromagnetic disturbances in which case the user may be required to take adequate mitigation measures.



For more detailed electrical data and specifications, see 1SFC132081M0201 - Softstarters Type PSTX30...PSTX1250, Installation and Commissioning Manual available on: <https://solutions.abb/softstarters>



Suitable For Use On A Circuit Capable Of Delivering Not More Than \_\_\_ Symmetrical Amperes, \_\_\_ Volts Maximum When Protected by \_\_\_ J Class Time Delay Fuses or RK5 class Fuses or circuit breaker. Refer to 1SFC132423M0201 for corresponding current and voltage level for any given device.

For complete short circuit protection recommendations see <https://solutions.abb/softstarters>









The product should only be used within the specified ratings. Be aware of the ambient temperature and altitude above sea level. Derating is required above 40 °C (104 °F) and above 1000 m (3281 ft). For more details, see 1SFC132081M0201 - Softstarters Type PSTX30...PSTX1250, Installation and Commissioning Manual available on: <https://solutions.abb/softstarters>



## 3 Mounting

The PSTX softstarters has different sizes that you can install with M6 bolts, or bolts with the same dimension and strength.

1. Find the correct drawing with dimensions for your softstarter and make sure that you have the correct drilling plan. Drilling plan is also printed on the box. 
2. If the softstarter is installed in an enclosure, make sure that the enclosure size is not smaller than the minimum recommended. Select the size from the applicable table for IEC or  . 
3. Make sure that the distance to the wall and the front, and the installation angle meet the requirements. 
4. Make sure that there is free flow of air through the product. 
5. You can remove the HMI and use it as a remote control. Drill a hole where you want to install the HMI. Use RJ45 cable between the HMI and the softstarter. The maximum cable length is 3 m. Roll together the remaining cable to prevent blockage of the door. 



*Use the provided cable or another non shielded RJ45 cable. Shielded cables should not be used.*



*Risk of damage to property. Make sure that no liquids, dust or conductive parts can go into the softstarter.*



*If you do not obey these instructions, this can cause the softstarter to become overheated or not operate correctly.*

## 4 Connection

This product is carefully manufactured and tested but there is a risk that damage can occur from such as shipment and incorrect operation. Obey to the procedure below during initial installation:



*Hazardous voltage: Will cause death or serious injury. Turn off and lock out all power that supply this device before you start work on the equipment.*



*Mounting and electrical connection of the softstarter must be made by authorized personnel and in accordance with existing laws and regulations.*



*Apply the control supply voltage to make sure that the by-pass relays are in open position before you connect the softstarters PSTX30... PSTX170 to operational voltage for the first time. If not, the equipment can start accidentally.*



*ABB personnel must obey to the ABB CISE 15.4 instructions.*

1. To mount the softstarter, refer to Chapter 3 “Mounting”.
2. Connect the main circuit: terminals 1L1 - 3L2 - 5L3 to the line side and terminals 2T1 - 4T2 - 6T3 to the motor side. Use wire connection for PSTX30...105, see Figure ① in graphics 7, and terminal connection for PSTX142...1250, see Figure ②, in graphics 7.



PSTX softstarters can be connected both “In Line” and “Inside Delta” see figure 1.



*Use only wires of same dimension when you connect 2 wires on each terminal (PSTX30...105 only).*

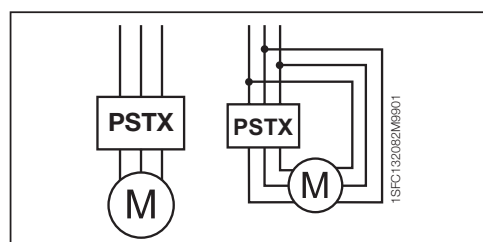


Figure 1: In Line, Inside Delta



*Capacitors for power factor compensation are not allowed between the softstarter and the motor, since this can cause current peaks which can damage the thyristors in the softstarter. If you use such capacitors, they must be connected on the line side of the softstarter.*

3. **Connect control supply voltage to terminals 1 and 2.**



4. **Connect terminal 22 to the functional earth.**



*The earthing is not a protective earth, it is a functional earth. The earthing cable must be as short as possible. Maximum length 0.5 m. The earthing cable must be connected to the mounting plate, which must also be earthed.*

5. **Look at the diagram and connect the start/stop circuits: terminal 13, 14, 18, 19 and 20/21, with the internal 24V DC terminal. When using internal 24 V DC (terminals 20 or 21), the terminals 18 and 19 should be connected to each other.**



*Terminal 15, 16 and 17 are programmable inputs for purposes such as reset, slow speed forward, slow speed reverse, stand still brake etc.*



*For usage of external supply see 1SFC132081M0201 - Softstarters Type PSTX30...PSTX1250, Installation and Commissioning Manual available on: <https://solutions.abb/softstarters>*



*Use 24V DC only when you connect terminal 13, 14, 15, 16 and 17. Other voltages can cause damage to the softstarter and the warranty will no longer be valid.*

6. **Connect terminals 4, 5, 6, 7, 8, 9, 10, 11 and 12 to use the signal output relays. These are potential free contacts for maximum 250 V AC, 1.5 A AC-15 and 30 V DC, 5 A DC-12.**



7. **Check that the operational voltage and control supply voltage correspond to the softstarter ratings.**

8. **Switch ON the control supply voltage, terminals 1 and 2.**

9. **Configure applicable parameters given in chapter 6, Softstarter settings.**

## 10. Switch the operational voltage to ON.

You can be flexible when you connect the PSTX softstarter, but following the previous steps will enable operation of the PSTX softstarter. You can find an example of a full installation in the graphics section. The first one uses fuses and contactors and the second one uses a circuit breaker.



Z

Refer to the timing diagram graphics 13 for the basic behaviour of PSTX softstarter.



### Built in Modbus RTU

The PSTX softstarter has an RS485 physical interface (terminals 23 and 24), that can be connected to external devices which have support for RS485 based communication. Through this interface it is possible to control the softstarter, retrieve status information and upload and download parameters. The softstarter has a Modbus RTU slave implemented via the RS485 interface. See **Figure 2**.

### PTC/PT100 temperature sensor input

The softstarter has input terminals for PTC and PT100 elements (terminals 25, 26 and 27). Please note that both PTC and PT100 cannot be used at the same time. See **Figure 2**.

### Analogue output

The softstarter has one output for a configurable analog output signal (terminals 29 and 30). The load resistance is maximum 500 ohm for current output and minimum 500 ohm for voltage output. See **Figure 2**.

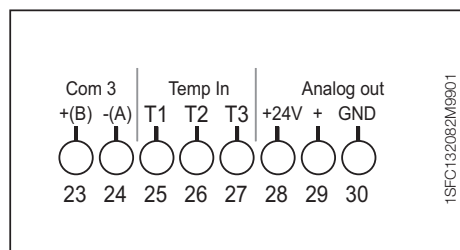


Figure 2: Terminal connection



For instructions and programming see  
1SFC132081M0201 - Softstarters Type PSTX30...PSTX1250, Installation and Commissioning Manual available on:  
<https://solutions.abb/softstarters>

# 5 Human machine interface (HMI)

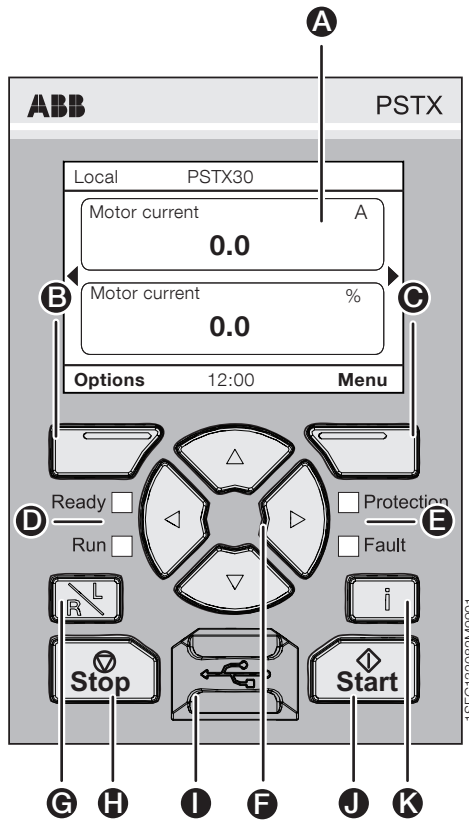


Figure 3: HMI

Refer to **figure 3** for the HMI parts:

- A** Display for information.
- B** Left selection soft key. The function is showed to the left in the display above the key.
- C** Right selection soft key. The function is showed to the right in the display above the key.
- D** Left LED indicators. Ready (green) and Run (green).
- E** Right LED indicators. Protection (yellow) and Fault (red)
- F** Navigation keys. To navigate in the menu and change the parameter values. Highlighted black board on numbers or text shown in the display indicates that the menu/value can be changed or scrolled
- G** Remote/local-key. Switch between local control from the HMI and remote control from hardwire input or fieldbus.
- H** Stop-key. Stop-switch for the softstarter. To stop the motor according to the set parameters. (Only active in local control mode).
- I** Mini USB port. For communication with external devices, eg. a PC.
- J** Start-key. Start-switch for the softstarter. To start the motor and operate it according to the set parameters. (Only active in local control mode).
- K** Information-key. For context-sensitive information about the softstarter status and settings.

Refer to the timing diagram in **graphics 13** for the basic behaviour of PSTX softstarter.



# 6 Softstarter settings

## 6.1: First start-up

When the softstarter is powered up for the first time the HMI will enter the Basic set-up assistant \*\*. See figure 6, graphics 14.





After the set-up is complete you will enter the **Home view**.






## 6.2: Assistants menu

For an initial configuration of the softstarter it is recommended to use the Assistants. An Assistant is a step-by-step wizard which guides the user through a group of tasks to set-up and configure the softstarter.

### Menu ► Assistants

Push , **Menu**, to enter the menu. Use  or  to highlight **Assistants** and push , **Select**.

Assistants menu	
Basic set-up	Application set-up
1. Language	1. Application set-up
2. Date and time	2. Keep/Change values
3. Motor data **	3. Tune settings
4. System configuration	4. Set-up complete
5. Set-up complete	

Use ,  and , to navigate through the steps and change the values.

See **table 6.3** for a list of the parameters, and their recommended values, which can be configured through the Application set-up assistant.



\*\* All PSTX softstarters must be configured to the rated current of the motor. If the PSTX is connected In Line, set the parameter "01.01 Motor rated current  $I_e$ " to the value found on the rating plate of the motor. If the PSTX is connected Inside Delta, set the parameter "01.01 Motor rated current  $I_e$ " to  $(1 / \sqrt{3}) = 58\%$  of the rated motor current.

Table 6.3: Application settings

		Recommended basic setting						
		Start ramp time	Stop ramp time	Start ramp initial level	Stop ramp end level	Current limit level	Start mode	Stop mode
Normal start (class 10)	Band saw	10	-	30	30	4	Voltage ramp	No ramp
	Bow thruster	10	-	30	30	3	Voltage ramp	No ramp
	Centrifugal pump	10	10	30	30	4	Voltage ramp	Torque ramp
	Circular saw	10	-	30	30	4	Voltage ramp	No ramp
	Conveyor belt short	10	-	40	30	3,5	Voltage ramp	No ramp
	Cutter	10	-	30	30	4	Voltage ramp	No ramp
	Escalator	10	-	30	30	3,5	Voltage ramp	No ramp
	High pressure pump	10	10	40	30	4,5	Voltage ramp	Torque ramp
	Hydraulic pump	10	-	30	30	3	Voltage ramp	No ramp
	Lift/Elevator	10	-	30	30	3,5	Voltage ramp	No ramp
	Piston compressor	5	-	50	30	3	Voltage ramp	No ramp
	Scroll compressor	2	-	50	30	3	Voltage ramp	No ramp
Heavy duty start (class 30)	Axial fan	10	-	30	30	4	Voltage ramp	No ramp
	Conveyor belt long	10	-	40	30	3,5	Voltage ramp	No ramp
	Crusher	10	-	30	30	4	Voltage ramp	No ramp
	Centrifugal fan	10	-	30	30	4	Voltage ramp	No ramp
	Grinder	10	-	30	30	4	Voltage ramp	No ramp
	Mixer	10	-	30	30	3,5	Voltage ramp	No ramp







Use the parameter values above as guidance only. Additional tuning can be necessary because of variations in load conditions.



## 6.4: Navigation overview

The softstarter has 10 keys on the keyboard, see **chapter 5** for details of the key function.






### Menu

Push  to go to the menu and then use  or  to select a menu item. Push  to make your selection, see **figure 1, graphics 14**. The settings in the HMI can be set with numerical setting, switch setting or selection list.








### The numerical setting




Use the numerical setting when a numerical value is to be set in the softstarter.

Use  and  key to select a figure, a black board highlights the selected figure. Then push  or  to change the value of the selected figure. Push , to save. See **figure 2, graphics 14**.

### On/off switch

With the switch you can select 1 or 0 (on or off). Use  and , a black board highlights the selected switch. Then push  or  to change the value of the selected switch. Push , to save. **See figure 3, graphics 14**.





### Selection list

Use  or , a black board highlights the selected option. Push , to save.

**See figure 4, graphics 14.**

## 6.5: Parameters

### Menu ► Parameters

Push , **Menu**, to enter the menu. Use  or  to select **Parameters** and then push , **Select**.

- Complete list - Set parameters
- Favourites - Create your own parameter list
- Modified - All parameters that differs from default

You can find the most common parameters in **table 6.7**.

## 6.6: Options settings

The options menu have the following selectable sub menus:

- Edit home view
- Active faults/protections
- Active warnings
- Configure HMI

Active faults/protections and Active warnings gives information about any fault, protection and warning that have occurred during operation. For fault solution see chapter 7 Trouble shooting.

**See figure 5, graphics 14.**



*For the sub-menus “Edit home view” and “Configure HMI” see 1SFC132081M0201 - Softstarters Type PSTX30...PSTX1250, Installation and Commissioning Manual available on: <https://solutions.abb/softstarters>*



*The motor can start unexpectedly if there is a start signal present, while you do any of the procedures below:*

- *Change from one type of control to a different one (i.e. fieldbus control to hardwire control or local to remote control)*
- *Reset events*
- *If you use automatic event reset*
- *If you use Auto restart*



**Table 6.7: Parameter list for operational function**

This is a selection of the most commonly used parameters.

For complete parameter list and setting range, see:

1SFC132081M0201 - Softstarters type PSTX30...PSTX1250, Installation and Commissioning Manual available on: <https://solutions.abb/softstarters>

Operation functions		
Parameter name	Setting range	Default value
1.1 Motor rated current I <sub>e</sub>	PSTX30: 9 ... 30 A <sup>①</sup>	30 A
2.1 Start mode	Voltage ramp, Torque ramp, Full voltage start	Voltage ramp
2.2 Stop mode	Voltage ramp, Torque ramp, No ramp, Dynamic brake	No ramp
2.3 Start ramp initial level	10 ... 99 %	30%
2.4 Start ramp time	1 ... 120s	10s
2.5 Stop ramp end level	10 ... 99%	30%
2.6 Stop ramp time	1 ... 120s	10s
3.1 Current limit type	Off, Normal, Dual, Ramp	Normal
3.2 Current limit level	1.5 ... 7.5 xI <sub>e</sub>	4.0 xI <sub>e</sub>
<b>Kick start</b> <sup>①</sup>	On/Off	Off
<b>Slow speed</b> <sup>①</sup>		
<b>Motor heating</b> <sup>①</sup>		
<b>Motor braking</b> <sup>①</sup>		
<b>Sequence start</b> <sup>①</sup>		
<b>Automatic restart</b> <sup>①</sup>		
26.12 Faulty connection operation	Stop-Manual, Stop-Automatic	Stop-Manual
28.5 Step down level	10 ... 100%	80%
28.41 System mode	Normal, Demo, Small motor	Normal
28.43 Mains connection	Auto, In line, Inside delta UI, Inside delta IU, Two phase (L1 Shorted), Two phase (L2 Shorted), Two phase (L3 Shorted)	Auto
28.42 Limp mode	On/Off	Off

<sup>①</sup> For full parameter list, see 1SFC132081M0201 - Softstarters Type PSTX30...PSTX1250, Installation and Commissioning Manual available on: <https://solutions.abb/softstarters>



<b>Protections</b>		
<b>Parameter name</b>	<b>Setting range</b>	<b>Default value</b>
13.1 EOL mode	Normal/Dual	Normal
13.2 EOL class	10 A, 10, 20, 30	10
13.3 EOL dual class	10 A, 10, 20, 30	20
13.5 EOL operation	Off, Stop-Manual, Stop-Automatic, Indication	Stop-Manual
13.10 Locked rotor operation	Off, Stop-Manual, Stop-Automatic, Indication	Off
14.5 Current underload operation	Off, Stop-Manual, Stop-Automatic, Indication	Off
15.4 Over voltage operation	Off, Stop-Manual, Stop-Automatic, Indication	Off
15.7 Under voltage operation	Off, Stop-Manual, Stop-Automatic, Indication	Off
16.2 Phase reversal operation	Off, Stop-Manual, Stop-Automatic, Indication	Off
16.9 By-pass open operation	Off, Stop-Manual, Stop-Automatic, Indication	Indication
18.5 Earth fault trip time	0,1s ... 10,0s	0,5s
18.7 Earth fault operation	Off, Stop-Manual, Stop-Automatic, Indication	Off
<b>Warnings</b>		
<b>Parameter name</b>	<b>Setting range</b>	<b>Default value</b>
20.1 EOL level	40 ... 99%	90%
20.3 EOL warning	On/Off	Off
20.7 Locked rotor	On/Off	Off
20.9 Thyristor overload	On/Off	Off
21.5 Current underload	On/Off	Off
22.4 Over voltage	On/Off	Off
22.8 Under voltage	On/Off	Off
23.1 EOL time-to-trip	On/Off	Off
23.4 THD(U) level	1...10%	10%
23.6 THD(U)	On/Off	Off
24.1 Number of starts limit	1 ... 65535	65535
24.3 Number of starts	On/Off	Off
23.8 Short circuit	On/Off	Off

# 7 Troubleshooting



Depending on PSTX Softstarter configuration, different events may be signalled on the display. See Event list Table 7.1.

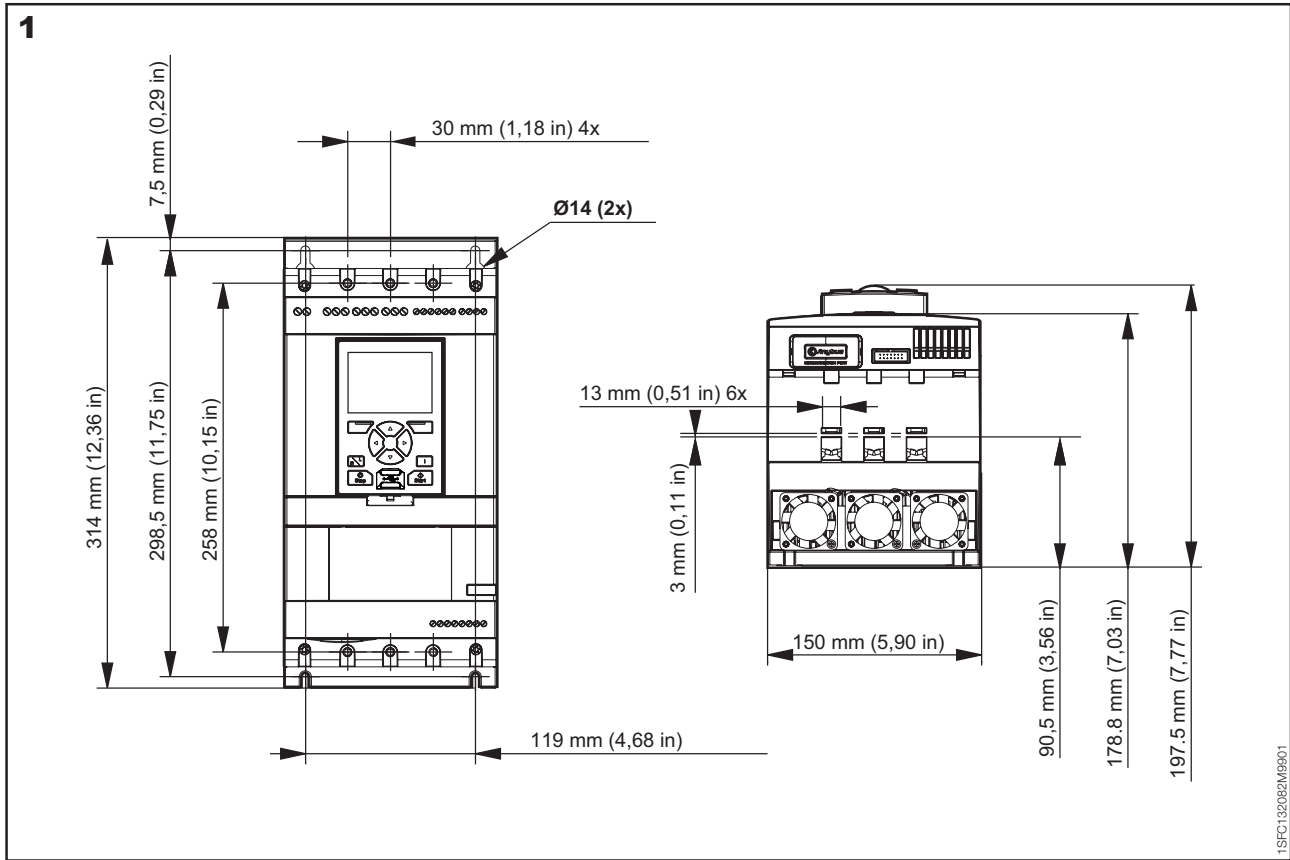
	<b>Table 7.1: Event list</b>	<b>Description</b>
<b>Protections</b>	Electronic overload	The motor has been overloaded because of too high current over a certain time. Check starting conditions and EOL settings.
	Locked rotor	The motor is running stiff. A damaged bearing or a stucked load could be possible causes. Check the load and the motor.
	Phase reversal	The phase sequence is not correct. Change the phase sequence on the line side to (L1→L2→L3).
	Current imbalance	Current imbalance between the phases. Restart the motor and check the main currents and voltage.
	Current underload	The motor current has fallen below the settable value. Check that the motor current parameter (Ie) is set correctly.
	User defined protection	Check the external sensor.
	Earth fault	Equipment protection. In a symmetrical three phase system, the sum of the instantaneous line currents is equal to zero. Earth fault indicates if the sum differs more than a settable value. This can indicate a serious condition of the motor.
	Over voltage	The mains voltage is too high. Check the mains voltage.
	Under voltage	The mains voltage is too low. Check the mains voltage.
	Voltage imbalance	Voltage imbalance between the phases. Restart the motor and check the mains voltage.
	PT100 protection	The external thermal sensor has detected a temperature higher than the trip level. Check the root cause of the overheating.
	PTC protection	The external thermal sensor has detected a temperature higher than the trip level. Check the root cause of the overheating.
	Power factor underload	The power factor has fallen below the trip level.
	Too long current limit	The time at current limit has exceeded the set value. The starting condition is too heavy for the set current limit. Check starting conditions and parameters.
	Bypass open fault	The bypass contactor or relay does not close when reached TOR. Contact ABB sales office for service.
	Fieldbus communication failure	There is a communication disturbance between the softstarter and PLC.
	24V output	Check the hardwire inputs.
	HMI failure	There is communication disturbance between the softstarter and the HMI. Check the connection to the HMI.
	Extension IO failure	There is communication disturbance between the softstarter and the extension I/O module. Check the connection to the I/O module.
	Max number of starts	The settable maximum number of starts per hour has been reached.
Auto-restart time-out	The time between trip and auto-restart attempt exceeds setting.	
Too long start time	It takes too long time to soft start the motor. Check starting conditions and current limit setting.	
Frequency range	The frequency has been outside the allowed range longer than the allowed time.	

		Description
<b>Faults</b>	High current	A fault current, higher than 8 times the softstarter ratings, has occurred. Check the circuits including the motor for any insulation fault, phase to phase fault or earth fault.
	Phase loss	Voltage to one or more phases missing. Check that the mains are connected and that no line contactor or breaker is open.
	Heat sink overtemperature	The heat sink temperature is too high. Check the starting conditions and the fans. Increase current limit if needed. Let the softstarter cool down before restart.
	Bad network quality	Excessive disturbances in the operational supplying network. Check for harmonics or frequency disturbance in the supply network.
	Shunt fault	The softstarter can not stop the motor due to internal short circuit. Contact ABB sales office for service.
	Low supply voltage	Too low control supply voltage on terminals 1 and 2. Check for voltage dips or interruptions.
	Thyristor overload	The thyristors are overheated. Check the starting conditions and the fans. Increase current limit if needed. Let the thyristors cool down before restart.
	Short circuit thyristor	One or several thyristors are shorted. Contact ABB sales office for service.
	Open circuit thyristor	One or several thyristors are not conducting. Contact ABB sales office for service.
	Unspecified fault	Internal fault in the softstarter. Disconnect and reconnect the supply voltage. If fault remains, contact ABB sales office for service.
	Invalid ID	A valid softstarter ID has not been set.
	Faulty connection	Motor is connected in a faulty way.
	Faulty usage	It is not allowed to use the functions jog, motor heating and stand still break when the softstarter is connected inside delta.

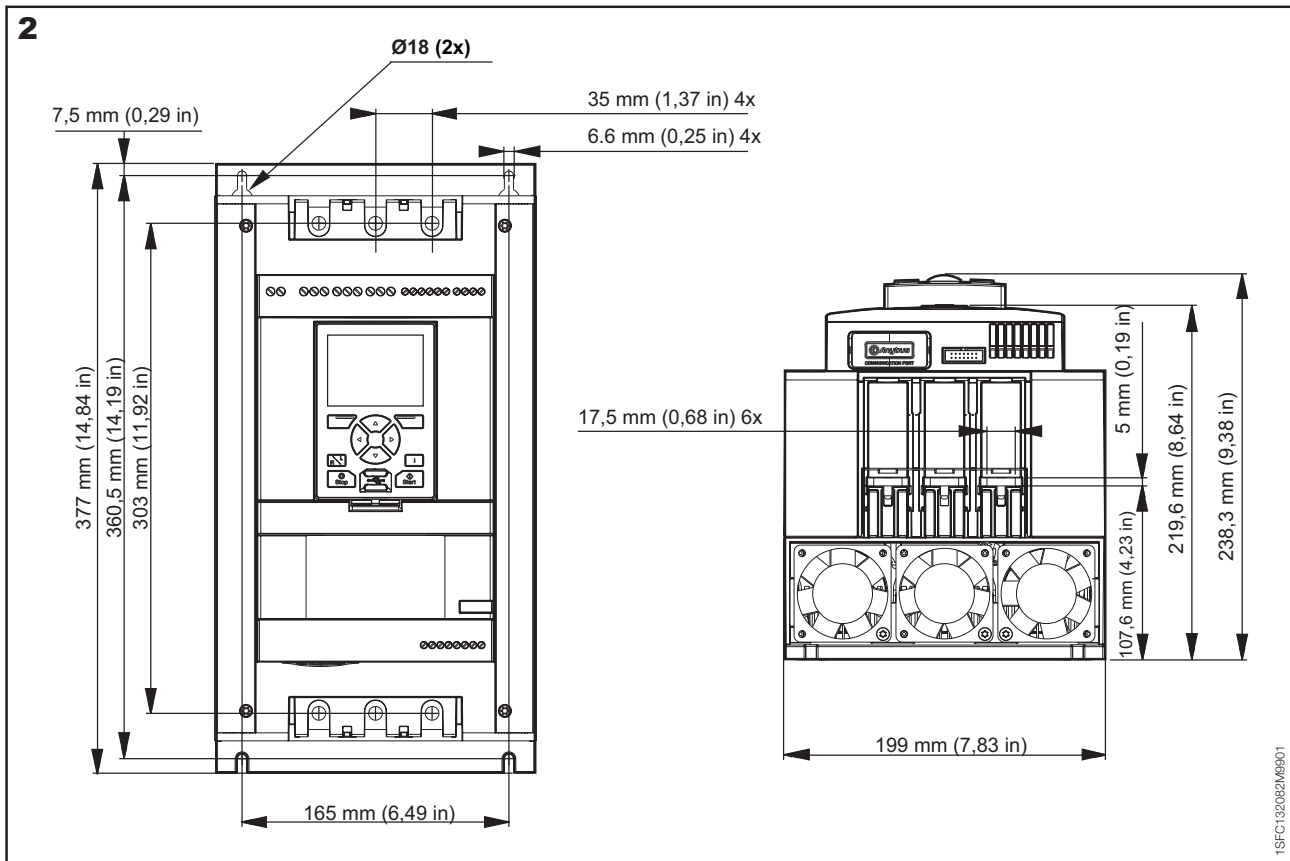


		Description
Warning	Current imbalance	Current imbalance between the phases. Restart the motor and check the mains currents and voltage.
	Current underload	The motor current has fallen below the warning level. Check that the motor current parameter (Ie) is set correctly.
	Fan failure	One or several fans are not working properly. Risk of overheating. Contact ABB sales office for service.
	EOL warning	The motor is nearly overloaded because of too high current over a certain time. Check starting conditions and EOL settings.
	Locked rotor	The motor current has exceeded the warning level. The motor is running stiff. A damaged bearing or a stucked load could be possible causes. Check the load and the motor.
	Over voltage	The main voltage is nearly out of range.
	Under voltage	The main voltage is nearly out of range.
	Power factor underload	The power factor has fallen below the warning level.
	THD(U)	THD has exceeded the warning level. Check quality of the network.
	Thyristor overload	The calculated thyristor temperature has exceeded the warning level. Check the starting conditions and the fans. Increase current limit if needed.
	Voltage imbalance	Voltage imbalance between the phases has exceeded the warning level. Check the mains voltage.
	Short circuit	There is an internal short circuit and the softstarter is running in limp mode. Contact ABB sales office for service.
	EOL time-to-trip	The predicted time before EOL trip has fallen below the warning level.
	Phase loss	Voltage to one or more phases missing. Check that the mains are connected and that no line contactor or breaker is open.
	Number of starts limit	The configurable limit for Number of starts (resettable) have been reached. The warning will stay active until the Number of starts (resettable) value have been reset. Use menu: Menu → Settings → Reset to defaults → Reset operating data and select Number of starts (resettable) to perform the reset.
Motor run time limit	The configurable limit for Motor run time (resettable) have been reached. The warning will stay active until the Motor run time (resettable) value have been reset. Use menu: Menu → Settings → Reset to defaults → Reset operating data and select Motor run time (resettable) to perform the reset.	

**PSTX30...PSTX105**

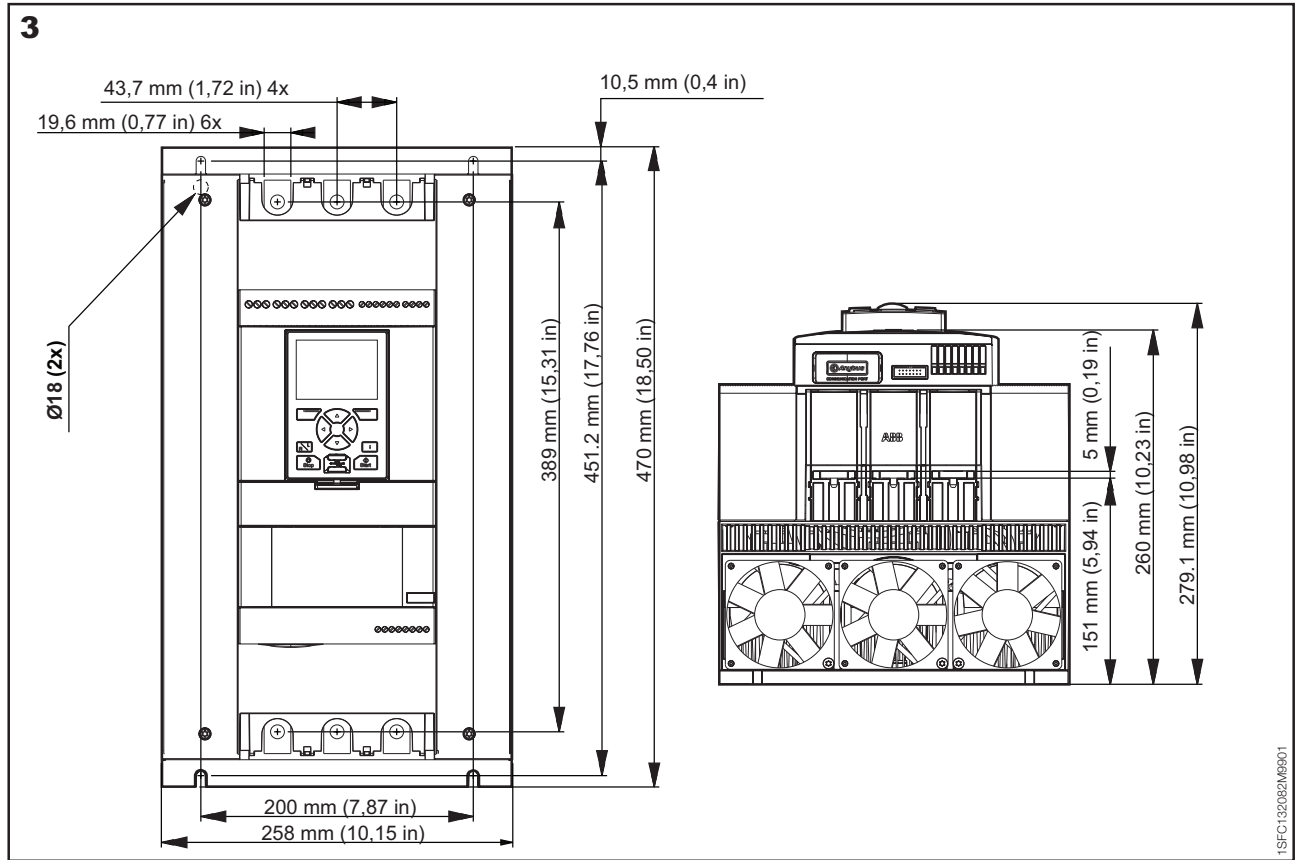


**PSTX142...PSTX170**

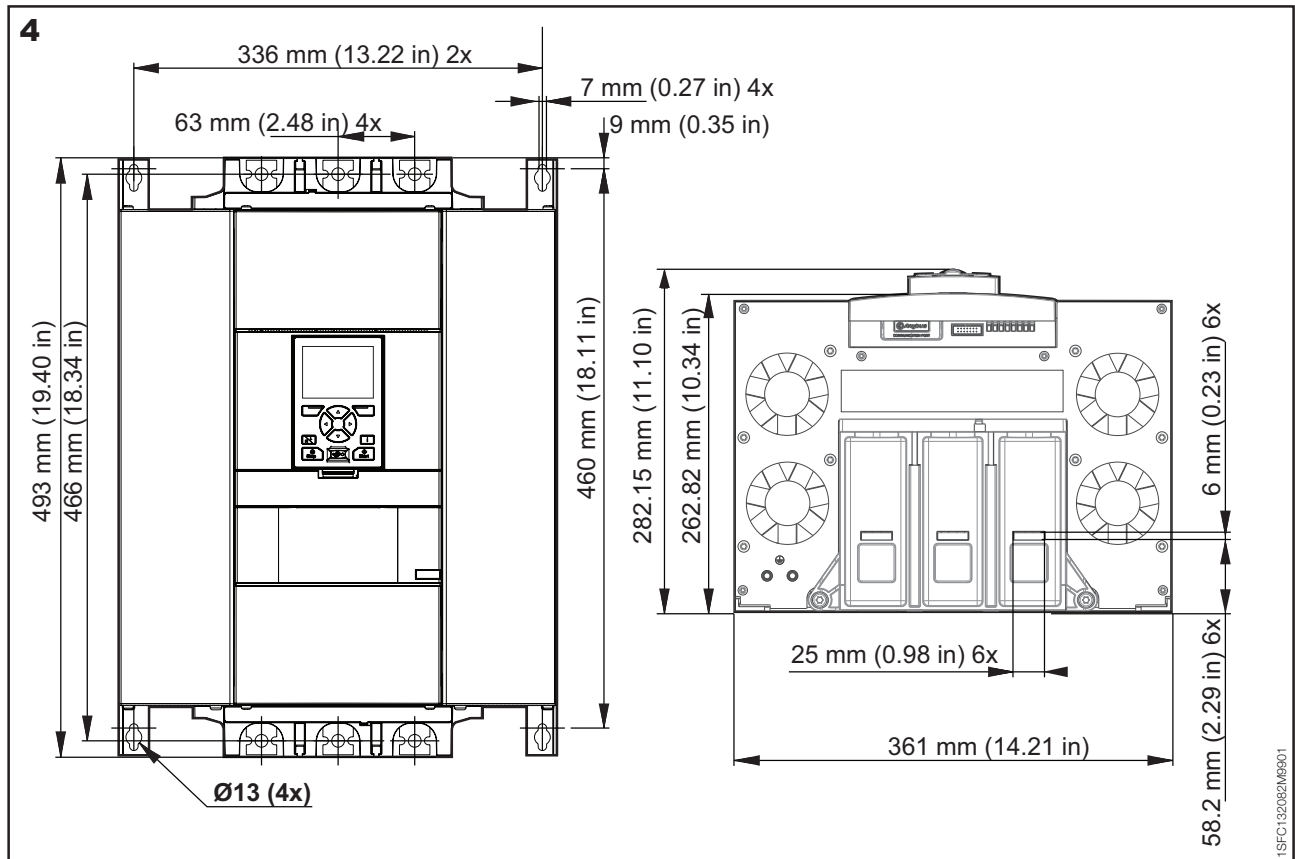




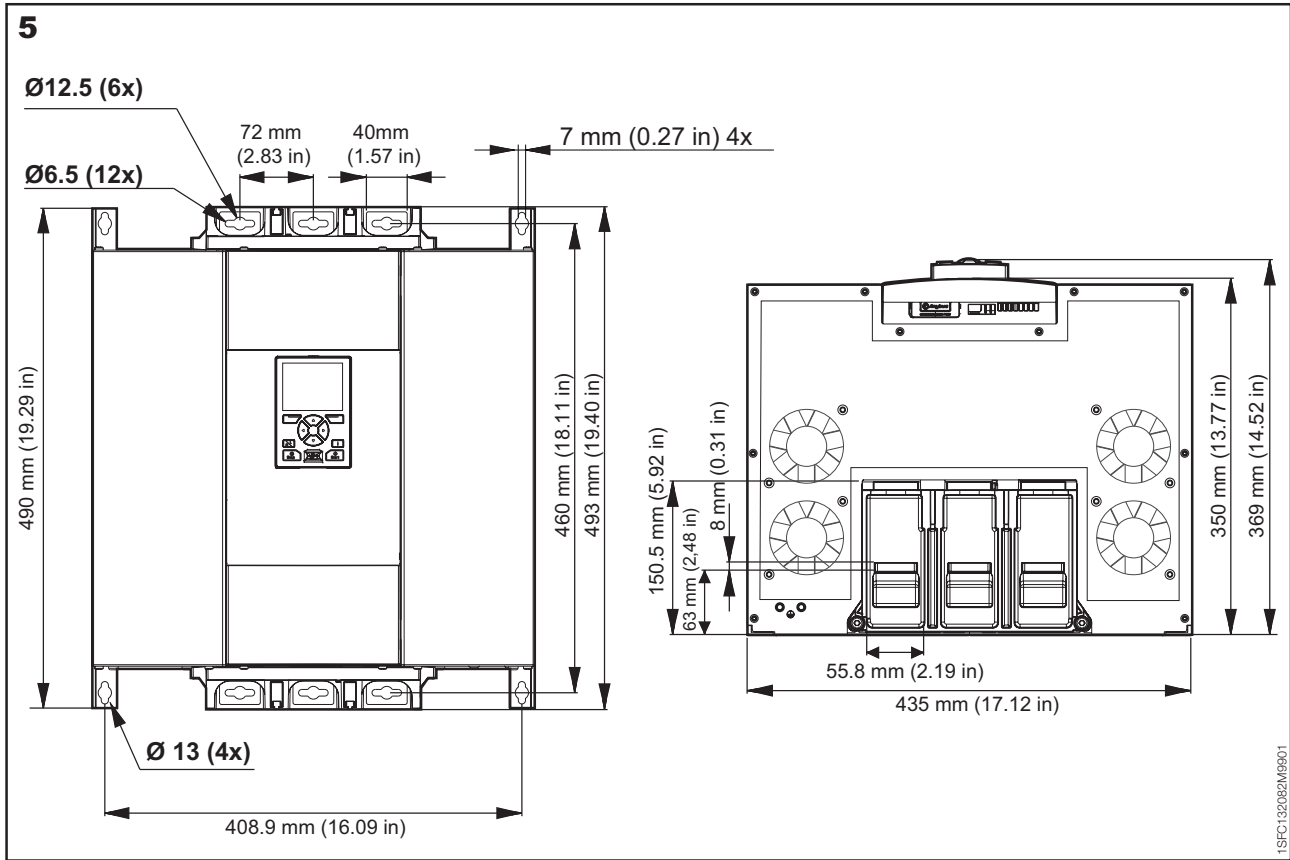
**PSTX210...PSTX370**



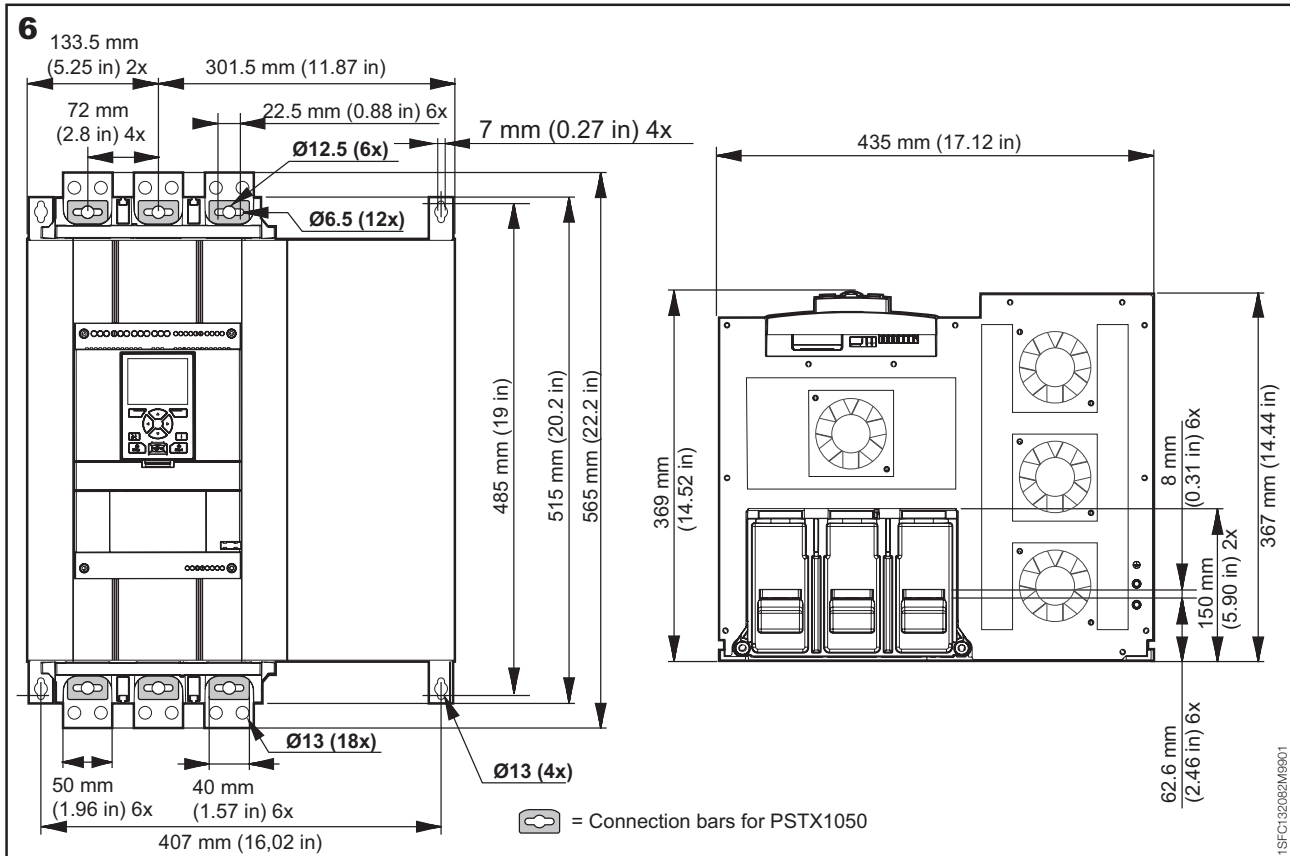
**PSTX470...PSTX570**



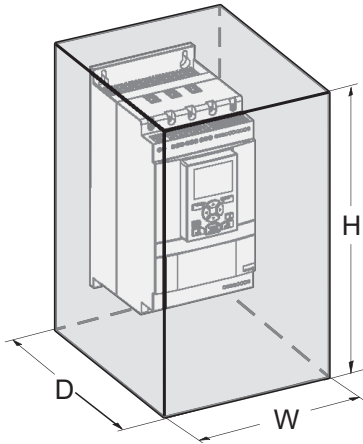
**PSTX720...PSTX840**



**PSTX1050...1250**



**03**

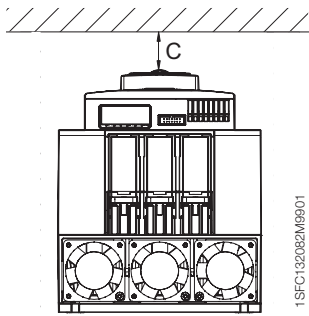


1SFC132082M9901

IEC	H (mm)	W (mm)	D (mm)
PSTX30...105	610	508	305
PSTX142...170	762	610	305
PSTX210...370	914	762	305
PSTX470...570	1219	914	405
PSTX720...840	1524	914	405
PSTX1050...1250	1524	914	405

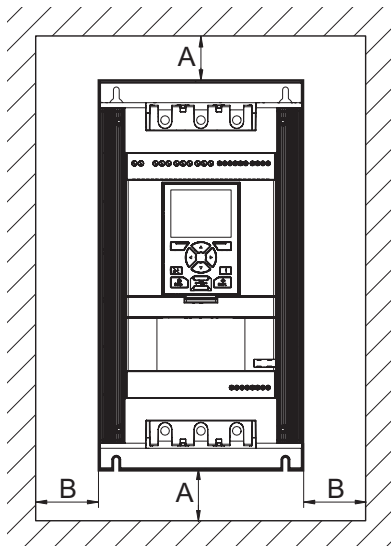
cULus	H (in)	W (in)	D (in)	Minimum number of latches
PSTX30...105	24	20	10	2
PSTX142...170	30	24	12	4
PSTX210...370	30	24	12	4
PSTX470...570	48	36	16	8
PSTX720...840	60	36	16	8
PSTX1050...1250	60	36	16	8

**04**

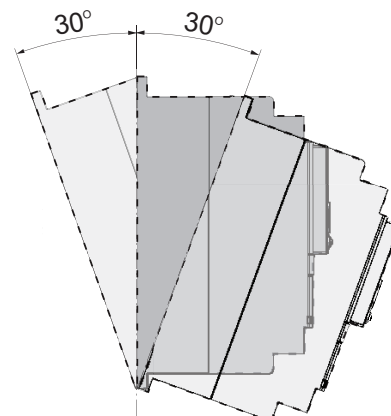
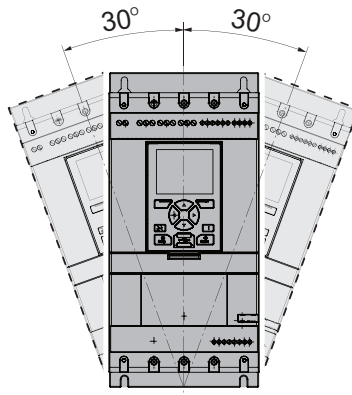


1SFC132082M9901

	A (mm)	B (mm)	C (mm)	A (in)	B (in)	C (in)
PSTX30...105	100	10	20	3.94	0.39	0.787
PSTX142...170	100	10	20	3.94	0.39	0.787
PSTX210...370	100	10	20	3.94	0.39	0.787
PSTX470...570	150	15	20	5.905	0.590	0.787
PSTX720...840	150	15	20	5.905	0.590	0.787
PSTX1050...1250	150	15	20	5.905	0.590	0.787



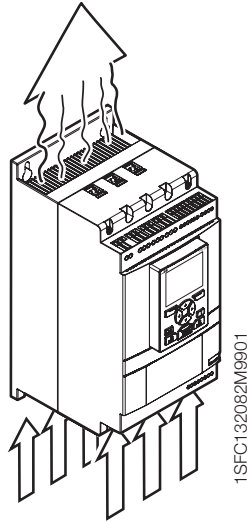
1SFC132082M9901



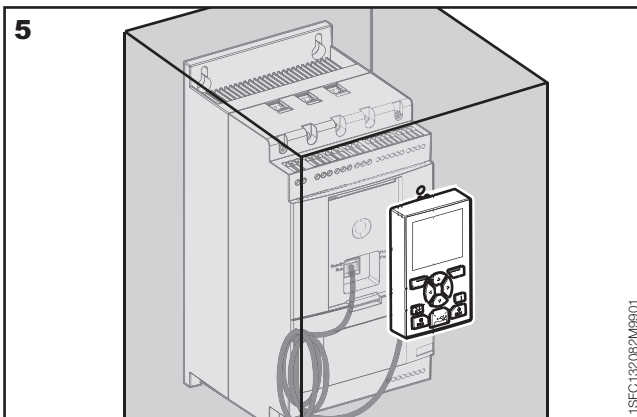
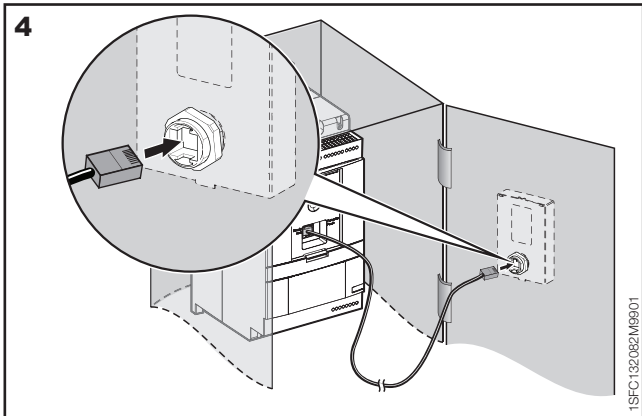
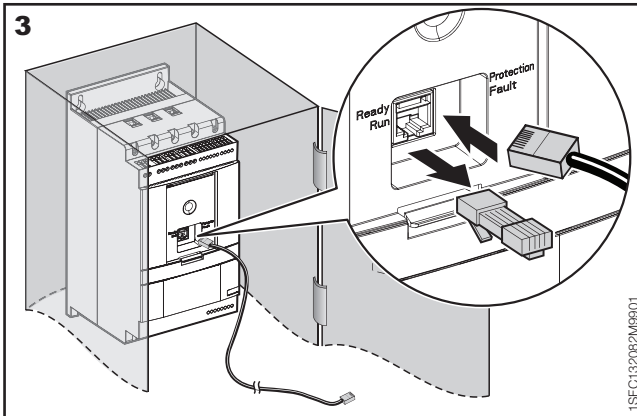
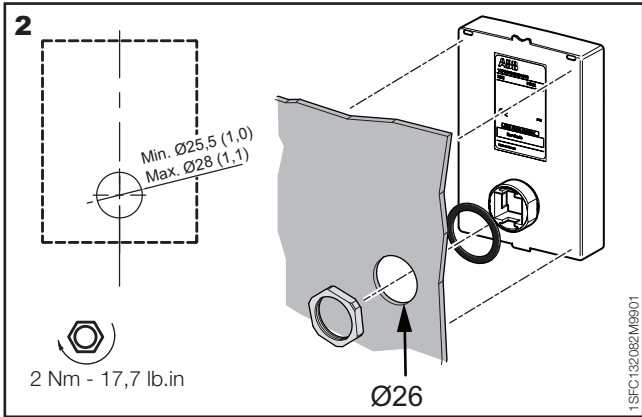
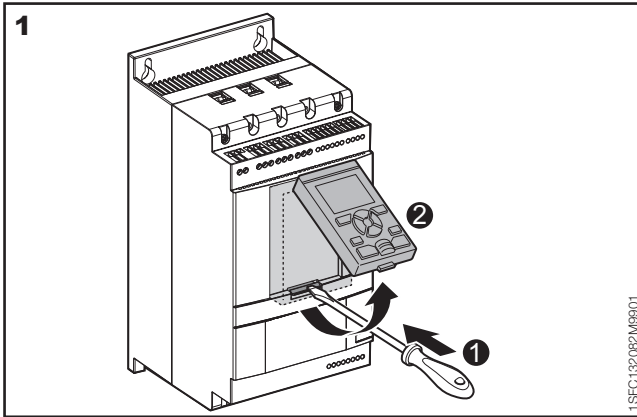
1SFC132082M9901

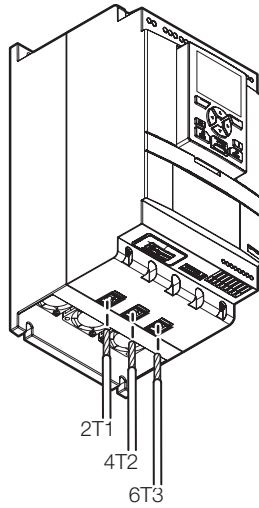
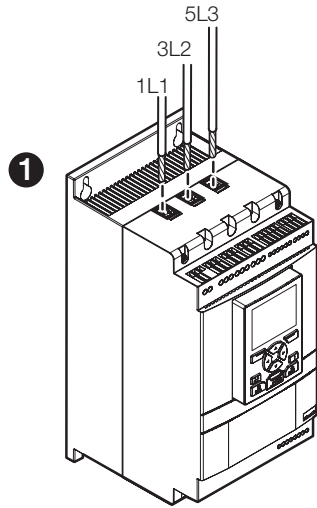


 **05**



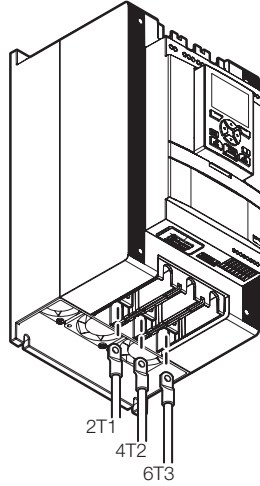
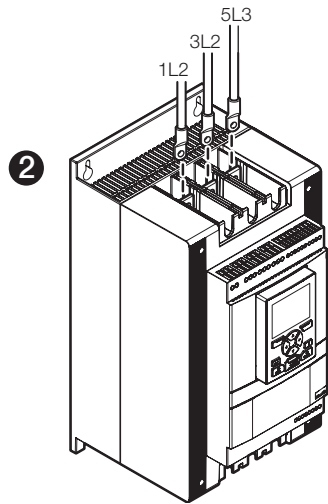
 **06**





1SFC132082M9901

PSTX30...105	
	<p><b>M8</b></p> <p>8 Nm - 71 lb.in</p> <p>AWG6 ... 2/0 Cu 75°C only Rigid: 10 ... 95 mm<sup>2</sup> Flexible: 10 ... 70 mm<sup>2</sup> Rigid/flexible: 2x6 ... 2x35 mm<sup>2</sup></p>



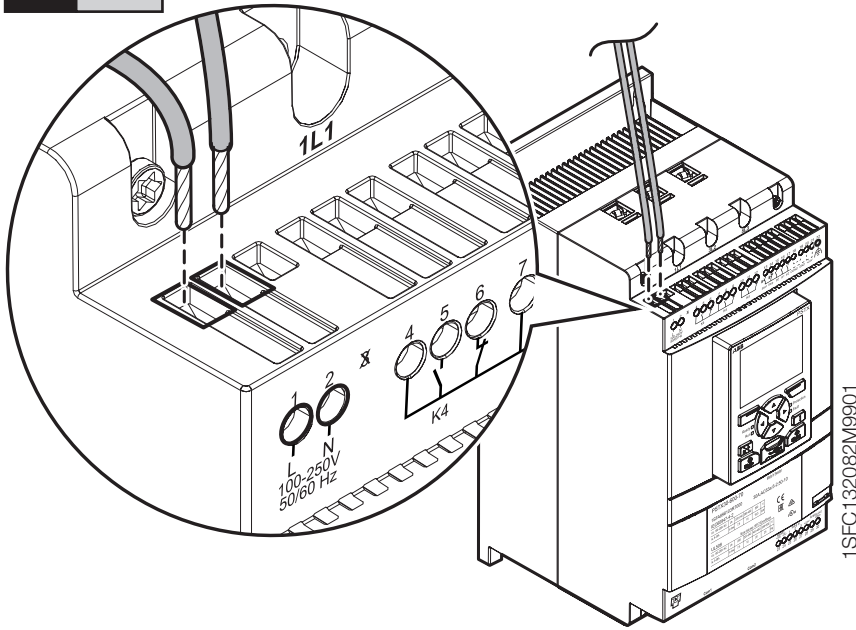
1SFC132082M9901

<p><b>PSTX142...170</b></p>	<p>11/6-16 UNF-2A</p> <p>275 lb.in</p>	<p>Using connection module</p> <p>ATK185: AWG4 to 300kcmil Al Cu 75°C only</p>	<p><b>M8</b></p> <p>18 Nm - 160 lb.in</p>	<p>Using connection bars</p>
<p><b>PSTX210...370</b></p>	<p>3/4-16 UNF-2A</p> <p>375 lb.in</p>	<p>Using connection module</p> <p>ATK300: AWG4 to 400kcmil ATK300/2: AWG4 to 500kcmil or 2xAWG4 to 2x500kcmil Al Cu 75°C only</p>	<p><b>M10</b></p> <p>28 Nm - 240 lb.in</p>	<p>Using connection bars</p>
<p><b>PSTX470...570</b></p>	<p>5/8-18 UNF-2A</p> <p>275 lb.in</p> <hr/> <p>3/4-16 UNF-2A</p> <p>375 lb.in</p>	<p>Using connection module</p> <p>ATK580/2: 2xAWG2/0 to 2x500 kcmil ATK750/3: 3xAWG2/0 to 3x500 kcmil Al CU 75° only</p>	<p><b>M10</b></p> <p>35 Nm - 310 lb.in</p>	<p>Using connection bar</p>
<p><b>PSTX720...840</b></p>	<p>5/8-18 UNF-2A</p> <p>275 lb.in</p> <hr/> <p>3/4-16 UNF-2A</p> <p>375 lb.in</p>	<p>Using connection module</p> <p>ATK580/2: 2xAWG2/0 to 2x500 kcmil ATK750/3: 3xAWG2/0 to 3x500 kcmil Al CU 75° only</p>	<p><b>M12</b></p> <p>45 Nm - 398 lb.in</p>	<p>Using connection bars</p>
<p><b>PSTX1050...1250</b></p>	<p><b>M12</b></p> <p>45 Nm - 398 lb.in</p>	<p>Using connection bars</p>	<p><b>M12</b></p> <p>45 Nm - 398 lb.in</p>	<p>Using connection bars</p>

1SFC132082M9901



**08**

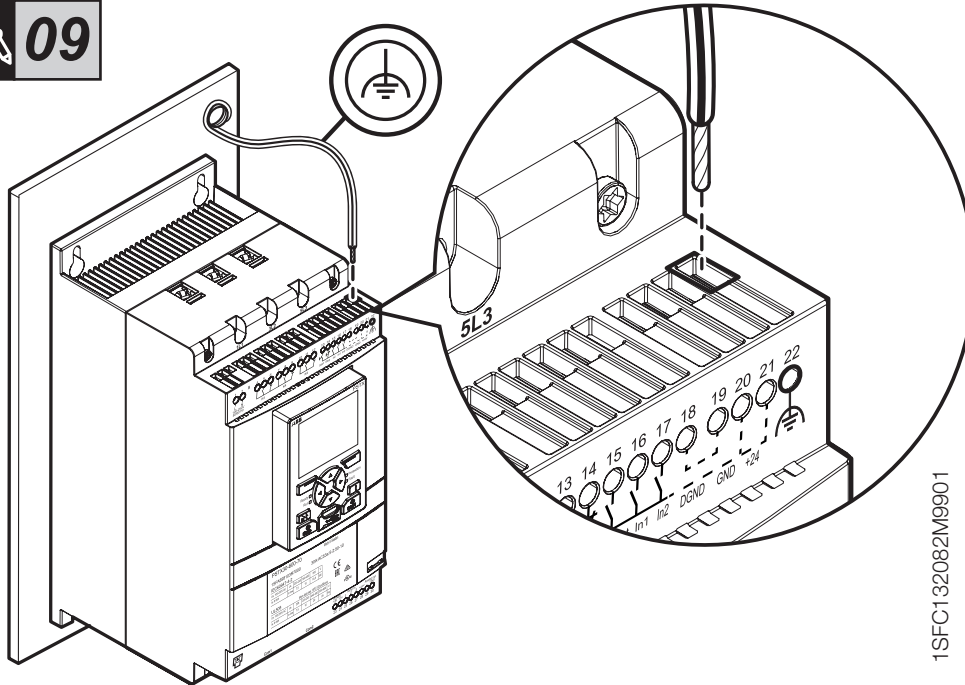


1SFC132082M9901

	<p>M3,5</p> <p>0,5 Nm 4,3 lb.in</p>	<p>3,5 x 0,6 mm (0.138 x 0.024 in)</p>	<p>AWG 12 ... 24</p> <p>0,2 .. 2,5 mm<sup>2</sup> 2x0,2 .. 1,5 mm<sup>2</sup></p> <p>0,2 .. 2,5 mm<sup>2</sup> 2x0,2 .. 1,5 mm<sup>2</sup></p>
--	---	--	--

1SFC132082M9901

**09**

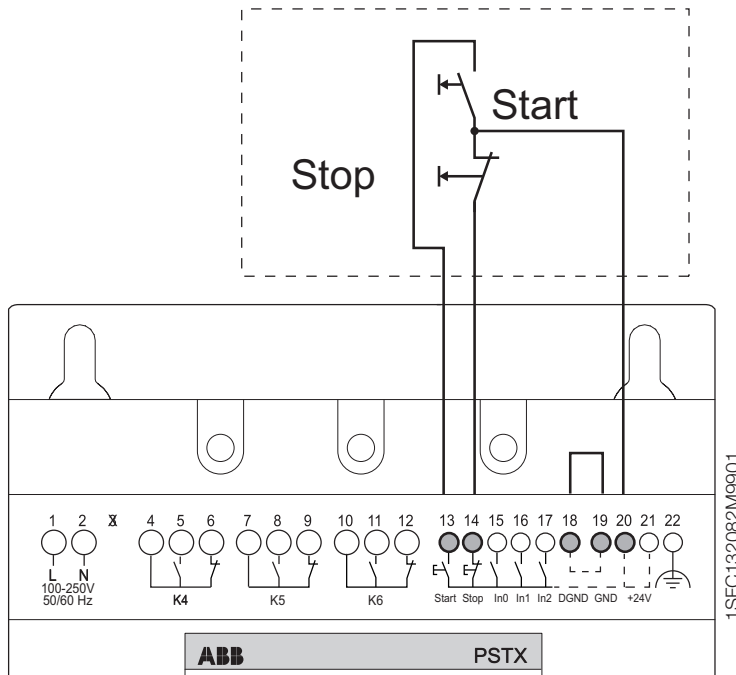


1SFC132082M9901

	<p>M3</p> <p>0,5 Nm 4,3 lb.in</p>	<p>3,5 x 0,6 mm (0.138 x 0.024 in)</p>	<p>AWG 12 ... 24</p> <p>0,2 .. 2,5 mm<sup>2</sup> 2x0,2 .. 1,5 mm<sup>2</sup></p> <p>0,2 .. 2,5 mm<sup>2</sup> 2x0,2 .. 1,5 mm<sup>2</sup></p>
--	---------------------------------------	--	--

1SFC132082M9901

**10**

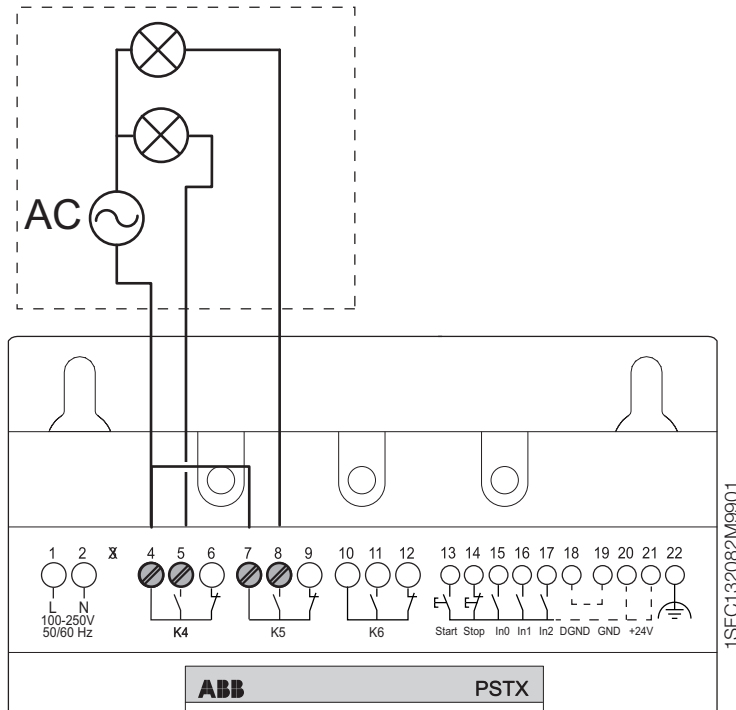


1SFC132082M9901

	<p><b>M3</b> 0,5 Nm 4,3 lb.in</p>	<p>3,5 x 0,6 mm (0.138 x 0.024 in)</p>	<p>AWG 12 ... 24</p> <ul style="list-style-type: none"> <li>0,2 .. 2,5 mm<sup>2</sup></li> <li>2x0,2 .. 1,5 mm<sup>2</sup></li> <li>0,2 .. 2,5 mm<sup>2</sup></li> <li>2x0,2 .. 1,5 mm<sup>2</sup></li> </ul>
--	---	--	---

1SFC132082M9901

**11**

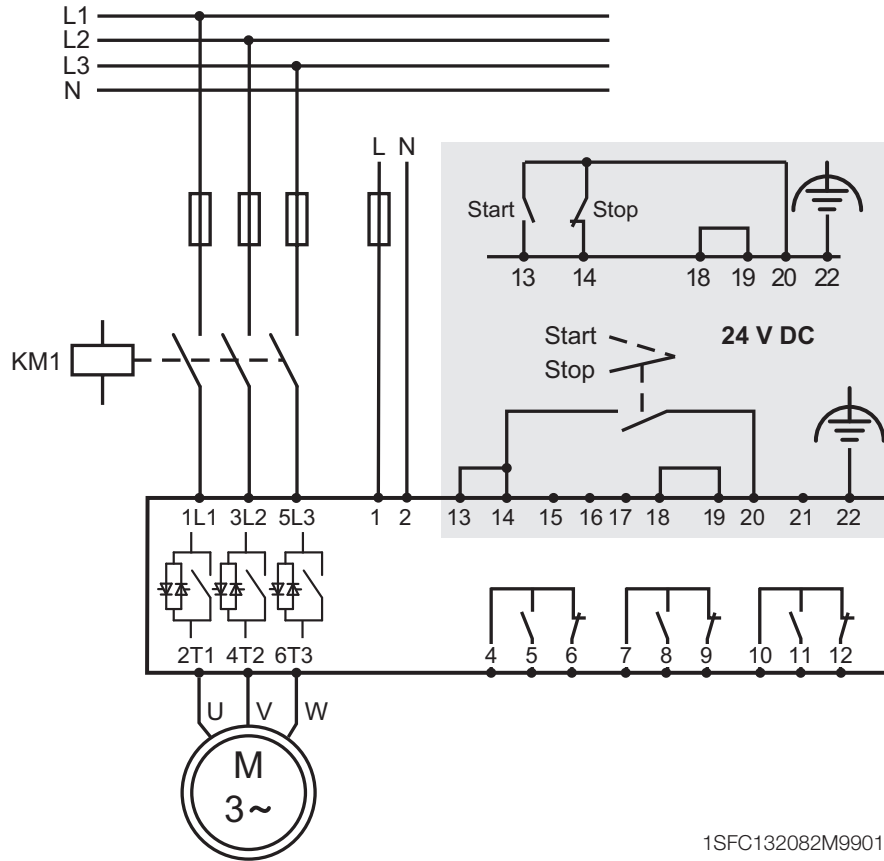


1SFC132082M9901

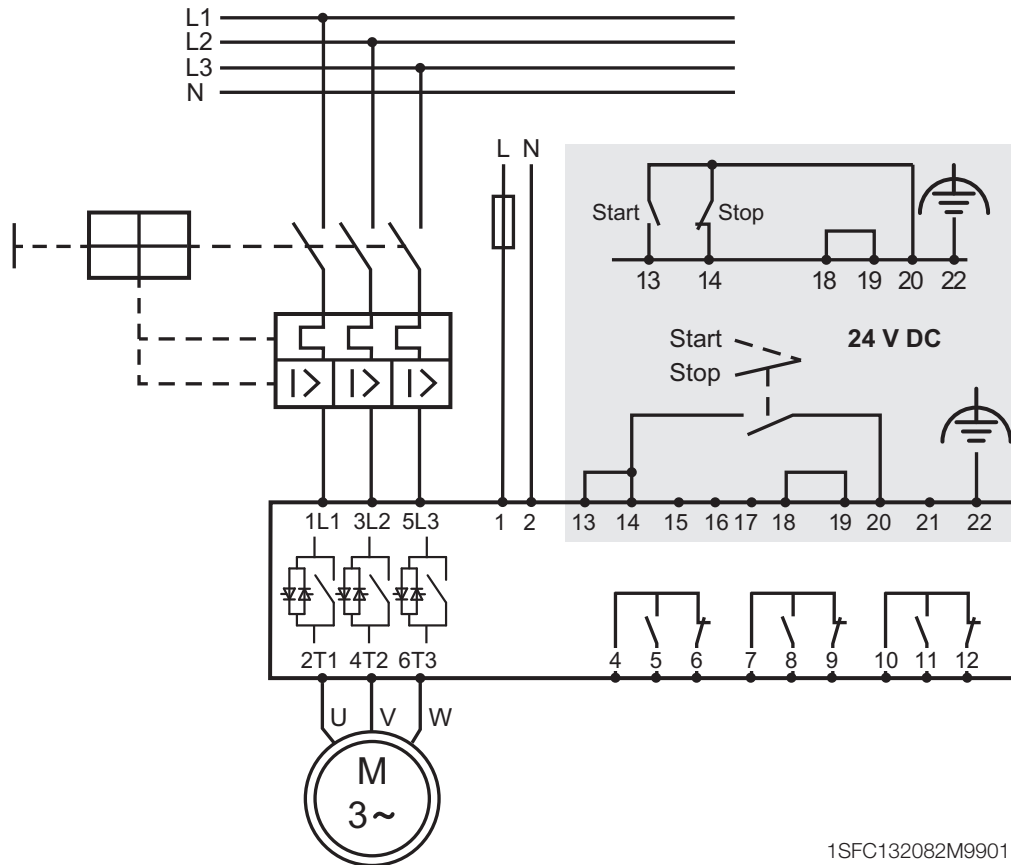
	<p><b>M3,5</b> 0,5 Nm 4,3 lb.in</p>	<p>3,5 x 0,6 mm (0.138 x 0.024 in)</p>	<p>AWG 12 ... 24</p> <ul style="list-style-type: none"> <li>0,2 .. 2,5 mm<sup>2</sup></li> <li>2x0,2 .. 1,5 mm<sup>2</sup></li> <li>0,2 .. 2,5 mm<sup>2</sup></li> <li>2x0,2 .. 1,5 mm<sup>2</sup></li> </ul>
--	---	--	---

1SFC132082M9901





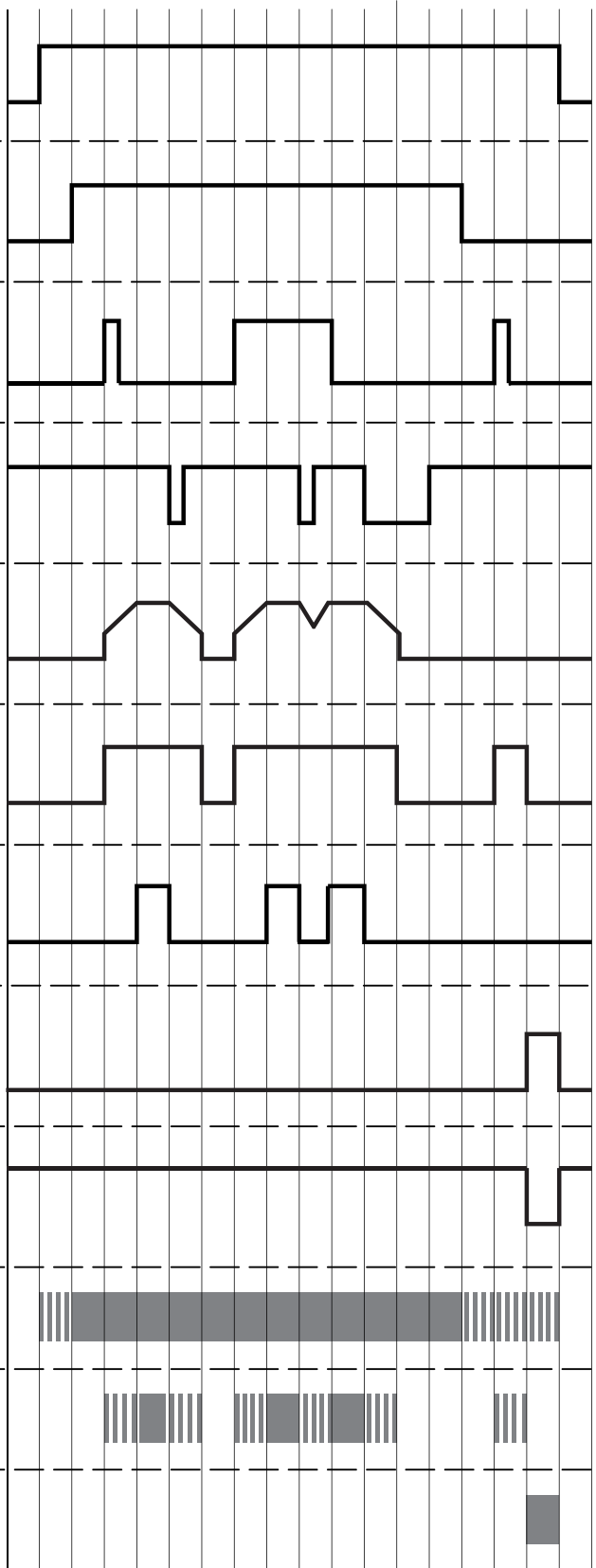
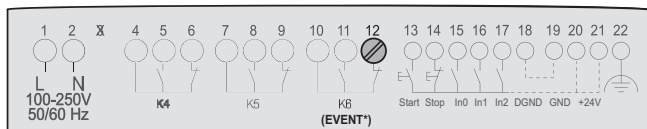
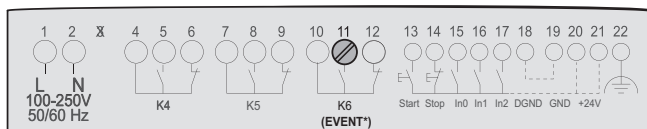
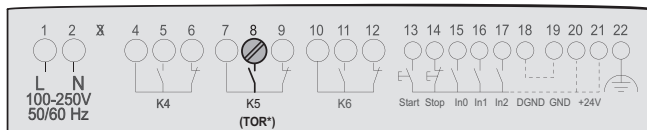
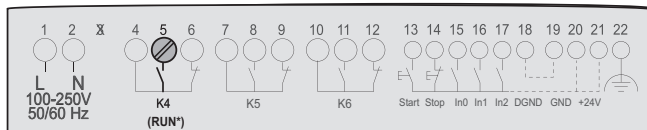
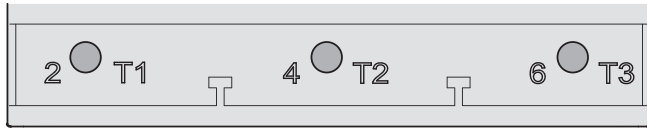
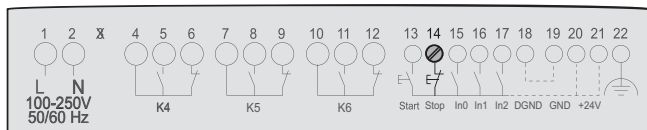
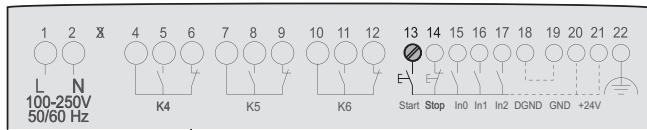
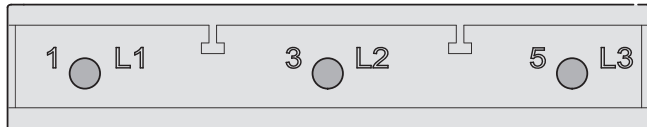
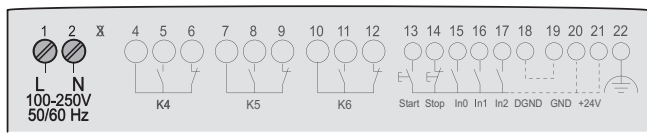
Circuit diagram PSTX30...PSTX1250 (Fuse and contactor version)



Circuit diagram PSTX30...PSTX1250 (MCCB version)

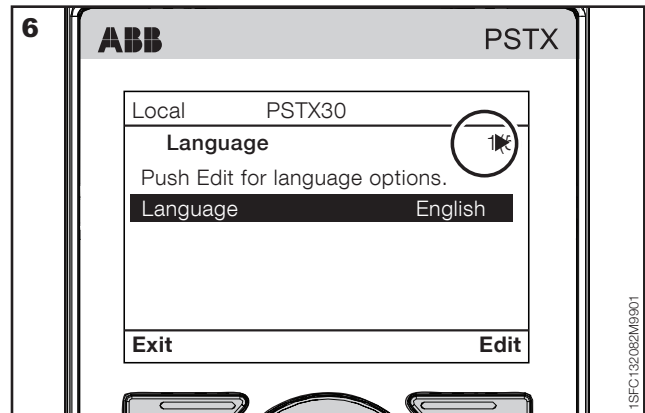
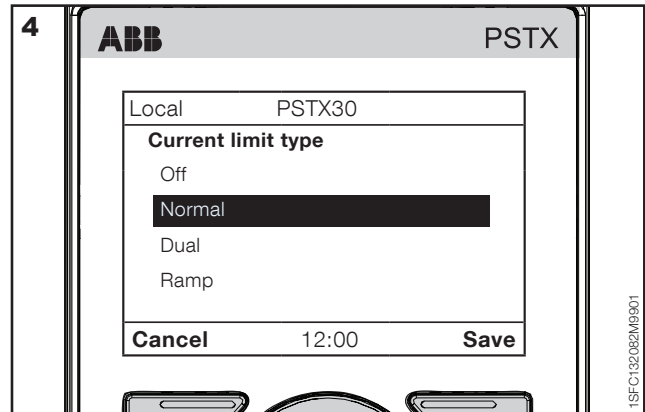
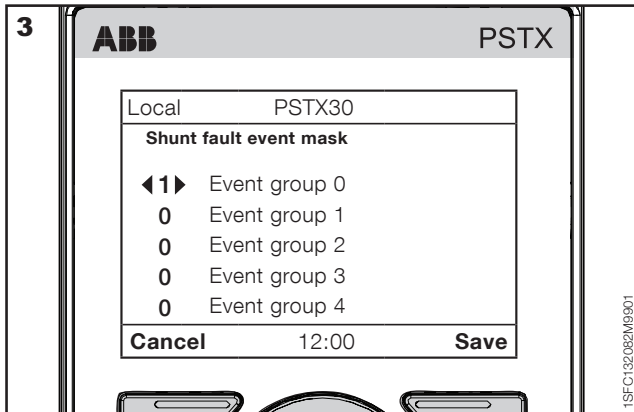
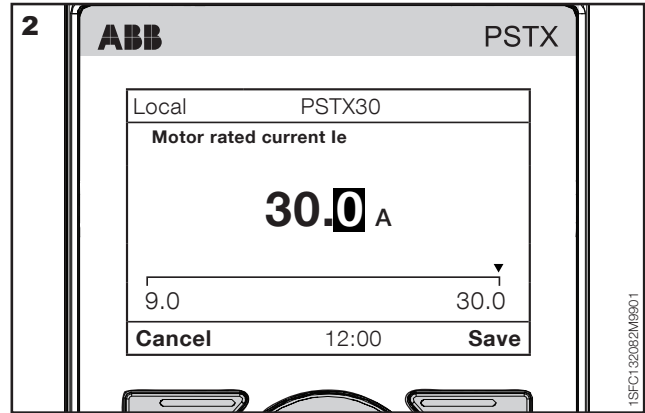






1SFC132082M9901







—

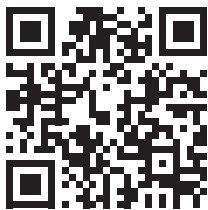
**ABB Electrification Sweden AB**  
**Smart Power - Motor Starting & Safety**

SE-721 61 Västerås

Sweden

E-mail: [sales@se.abb.com](mailto:sales@se.abb.com)

<https://solutions.abb/softstarters>



---

1SFC132081M0201

# Softstarters Type PSTX30...PSTX1250

## Installation and commissioning manual



# Original instruction

This is the Installation and commissioning manual for Softstarters Type PSTX30...PSTX1250.

Document number: 1SFC132081M0201

Revision: Q

Issue date: 2022-04-06

Data can be changed without notice.

We reserve all rights to this document, even in the event that a patent is issued and a different commercial proprietary right is registered. Improper use, in particular reproduction and dissemination to third parties, is not permitted.

This document is written carefully. If you find an error, please notify us as soon as possible.

The data contained in this manual is intended solely for the product description and is not to be deemed to be a statement of guaranteed properties. In the interests of our customers, we constantly seek to ensure that our products are developed to the latest technological

Author's address:

ABB Electrification Sweden AB  
Smart Power - Motor Starting & Safety  
SE-721 61 Västerås  
Sweden  
E-mail: [sales@se.abb.com](mailto:sales@se.abb.com)

<https://solutions.abb/softstarters>

© Copyright 2022. All rights reserved. Data can be changed without notice.

# Read this first

## Warning and safety

Thank you for selecting this ABB PSTX Softstarter.

Carefully read and make sure that you understand all instructions before you install, connect, configure the Softstarter.

This manual is intended for installation and advanced usage of the PSTX Softstarter. For quick and easy installation, see 1SFC132082M9901 - Softstarters Type PSTX30...PSTX1250 User Manual short form. The manual is available on: <https://solutions.abb/softstarters>

- Only authorized and appropriately trained personnel are permitted to install and make the electrical connection of the Softstarter. Obey all laws and regulations.
- Only authorized personnel are permitted to do service and repair on the Softstarter.
- Unauthorized repair will have an effect on the warranty.
- ABB personnel must obey the instructions in **ABB CISE 15.4**.
- This manual is a part of the PSTX Softstarter. Always keep this manual available when you work with the PSTX Softstarter.
- Examine the Softstarter and the package when you unpack your new PSTX Softstarter. If there are damages, please speak to the transportation company or the ABB reseller/office immediately.

### Safety notes

In the manual, these symbols are used



#### WARNING

General warning symbol indicates the presence of a hazard which could result in personal injury and damage to equipment or property.



#### WARNING

Warning symbol indicates the presence of hazardous voltage which could result in personal injury.



#### WARNING

Approved personnel are allowed to install and make the electrical connection of the Softstarter in accordance with existing laws and regulations.



#### INFORMATION

Information sign tells the reader important facts and conditions.

Changes to data in this manual can be applied without notice.

### General safety information



#### WARNING

Approved personnel are allowed to install and make the electrical connection of the Softstarter in accordance with existing laws and regulations.



#### WARNING

Examine the Softstarter and the package when you unpack your new PSTX Softstarter. If there are damages, please speak to the transportation company or the ABB reseller/office immediately.



#### WARNING

Only approved personnel are allowed to do service and repair.

Note: not approved repair can effect the warranty.

### Legal Disclaimer

The PSTX Softstarter is designed to be connected to and to communicate information and data via a network interface. It is customers sole responsibility to provide and continuously ensure a secure connection between the product and your network or any other network (as the case may be) and to establish and maintain any appropriate measures (such as but not limited to the installation of firewalls, application of authentication measures, encryption of data, installation of anti-virus programs, etc) to protect the PSTX Softstarter, the network, its system and the interface against any kind of security breaches, unauthorized access, interference, intrusion, leakage and/or theft of data or information.

ABB Ltd and its affiliates are not liable for damages and/or losses related to such security breaches, any unauthorized access, interference, intrusion, leakage and/or theft of data or information.

# Softstarters Type PSTX

## Installation and commissioning manual

<a href="#">1 Introduction</a>	<b>1</b>
<a href="#">2 Quick start</a>	<b>2</b>
<a href="#">3 Description</a>	<b>3</b>
<a href="#">4 Installation</a>	<b>4</b>
<a href="#">5 Connection</a>	<b>5</b>
<a href="#">6 Human machine interface (HMI)</a>	<b>6</b>
<a href="#">7 Functions</a>	<b>7</b>
<a href="#">8 Communication</a>	<b>8</b>
<a href="#">9 Maintenance</a>	<b>9</b>
<a href="#">10 Troubleshooting</a>	<b>10</b>
<a href="#">11 Wiring and application diagrams</a>	<b>11</b>
<a href="#">12 Third party licenses</a>	<b>12</b>
<a href="#">13 Revision</a>	<b>13</b>
<a href="#">14 Index</a>	<b>14</b>



# 1 Introduction

## 1.1 Documentation for Softstarter PSTX30...PSTX12500

8

1

### 1.1.1 Installation and commissioning manual

1.2 Intended audience ..... 9

1.3 Revision notes and other documents ..... 9

1.4 Acronyms and abbreviations ..... 9

This chapter gives an introduction to the Softstarter documentation manuals and its chapters, releases, intended audience and it tells about concepts.

## 1.1 Documentation for Softstarter PSTX30...PSTX1250

For the Softstarter types PSTX30...PSTX1250, these manuals and catalogs are available:

### 1SFC132081M0201

This document. Installation and commissioning manual (English version). See chapter **1.1.1 Installation and commissioning manual** more information.

### 1SFC132082M9901

Installation and commissioning manual - Short form. See chapter **1.1.2 Installation and commissioning manual - Short form** for more information.

These documents are available online in PDF format. A printed version of the "Installation and commissioning - Short form" is included with the Softstarter.

These manuals are available as online PDF-files:

Document ID	Language
1SFC132081M1301	AR Arabic
1SFC132081M2001	ZH Chinese
1SFC132081M4601	CS Czech
1SFC132081M0101	DE German
1SFC132081M0201	EN English
1SFC132081M0701	ES Spanish
1SFC132081M1801	FI Finnish
1SFC132081M0301	FR French
1SFC132081M0901	IT Italian
1SFC132081M3101	NL Dutch
1SFC132081M4001	PL Polish
1SFC132081M1601	PT Portuguese
1SFC132081M1101	RU Russian
1SFC132081M3401	SV Swedish
1SFC132081M1901	TR Turkish

These documents can be found at: <https://solutions.abb/softstarters>.

## 1.1.1 Installation and commissioning manual

This manual, "Softstarters Type PSTX30...PSTX1250 Installation and commissioning manual", contains instructions on how to install, commission and maintain the Softstarter. It gives procedures for mechanical and electrical installation, and installation of communication devices. It also gives information about energizing, settings and configuration.

To start quickly, see chapter **2 Quick start** or use the short form manual (1SFC132082M9901). For chapter content, see **Table 2 Chapter contents** below:

Chapters	Description
1. Introduction	Introduces the reader to this manual.
2. Quick start	Contains information for quick installation of the Softstarter and get it into operation.
3. Description	Gives a description of the Softstarter with specifications and a list of functions.
4. Installation	Contains information of the delivery, how to unpack and install the Softstarter.
5. Connection	Contains instructions to make the electrical connections, and connections for communication devices.
6. Human-Machine Interface	Gives a description of the Human-Machine Interface. Gives a description of all settings and navigation of the menu systems.
7. Functions	Gives a description of all functions of the Softstarter, with their minimum, maximum and default values. This chapter is intended for the experienced user.
8. Communication	Gives a description of the communication ports of the Softstarter.
9. Maintenance	Gives a description of the necessary maintenance and how to do it.
10. Troubleshooting	Contains instructions to find and correct the most common errors.
11. Wiring diagrams	Contains electrical and application diagrams for the Softstarter.
12. Third party Licenses	3 <sup>rd</sup> party licenses used by Softstarter
13. Revision	Shows all revisions of the manual
<b>14. Index</b>	<b>Index of the content of this manual</b>

## 1.1.2 Installation and commissioning manual - Short form

The "Softstarters Type PSTX30...PSTX1250 Installation and commissioning manual - Short form" contains brief information about the Softstarter:

- Installation
- Electrical connections
- Basic functions
- Troubleshooting

The short form contains the languages shown in **Table 1 Languages**. The short form has document ID 1SFC132082M9901.

## 1.2 Intended audience

### 1.2.1 General

The Installation and commissioning manual is intended for authorized installation, commissioning, and maintenance personnel.

### 1.2.2 Requirements for personnel

The installation personnel must have a basic knowledge in how to handle electrical equipment. The commissioning and maintenance personnel must have good experience in how to use electrical equipment. ABB personnel must obey the instructions in **ABB CISE 15.4**.

## 1.3 Revision notes and other documents

For latest information on revisions and other documents related to the PSTX Softstarters, please see <https://solutions.abb/softstarters>.

## 1.4 Acronyms and abbreviations

**Table 3** Acronyms and abbreviations

Acronym/ Abbreviation	Description
BP	Bypass
DOL	Direct-on-line
EOL	Electronic overload
FB	Fieldbus
FBP	Fieldbus Plug
HMI	Human-Machine Interface
$I_e$	Rated operation current
IT	Information Technology
LED	Light Emitting Diode
PCBA	Printed Circuit Board Assembly
PLC	Programmable Logic Controller
PTC	Positive Temperature Coefficient
SC	Short Circuit
SCR	Silicon Controlled Rectifier (thyristor)
THD	Total Harmonic Distortion
TOR	Top of Ramp (full voltage/Full-On)
$U_c$	Rated control circuit voltage, used for controlling the Softstarter. *
$U_e$	Rated operation voltage on the motor (3 phase main voltage feeding the motor). *
$U_s$	Rated control supply voltage, feeding the electronics in the Softstarter. *

\*) For definition see IEC 60947-1 edition 5.0



## 2 Quick start

<b>2.1 Connection</b>	12
<b>2.2 Configuration</b>	14
2.2.1 Basic set-up	14
2.2.2 Application set-up	15
<b>2.3 How to start/stop the motor</b>	15

This chapter is a short guide on how to connect, configure and start the Softstarter in an easy way.

This product was carefully manufactured and tested, but damage can occur during transportation. Therefore, obey these instructions:



**WARNING**

Dangerous voltage: Can cause death or serious injury. Always set the power switch to off and lock out all power to this device before you start to work on the equipment.



**WARNING!**

Installation of electrical connections must be done by authorized personnel. Obey all laws and regulations.



**WARNING!**

Before you connect the Softstarters PSTX30... PSTX170 to the operation voltage for the first time, apply control supply voltage to open the bypass relays. (see 2.1 Connection). This is necessary to avoid an accidental start of the equipment while it is connected to operation voltage.



**INFORMATION**

ABB personnel must obey the instructions in **ABB CISE 15.4**.

**2.1 Connection**

- To install the Softstarter see **chapter 4 Installation**.



**INFORMATION**

You can connect PSTX Softstarters In Line **1** and Inside Delta **2**, see **Figure 2.1**.

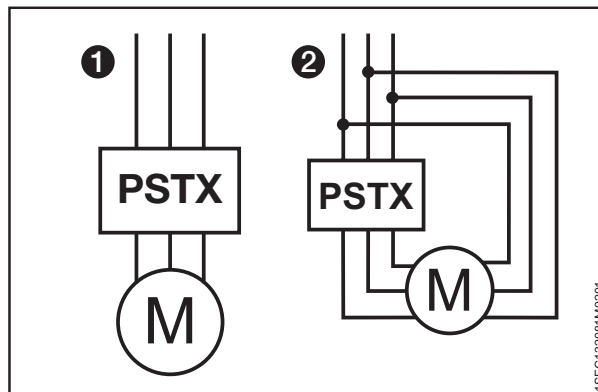
- Connect the main circuit: terminals 1L1 - 3L2 - 5L3 to the line side **1**, and terminals 2T1 - 4T2 - 6T3 to the motor side **2**, see **Figure 2.2**. Use wire connection for PSTX30...105, see **Figure 2.2** and terminal connection for PSTX142...570, see **Figure 2.3**.
- Connect the line side to terminals 1L1, 3L2, 5L3. see **1** and **Figure 2.2**. Connect the motor to terminals 2T1, 4T2, 6T3 on the motor side, see **2** **Figure 2.2** and **Figure 2.3**.



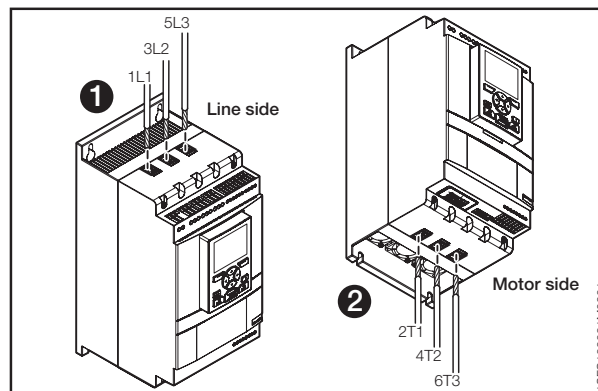
**WARNING!**

When using a softstarter in a network with high harmonic disturbances, there is a risk to damage the softstarter. An example could be installations were VSDs (variable speed drives) are connected to the same transformer as the softstarter.

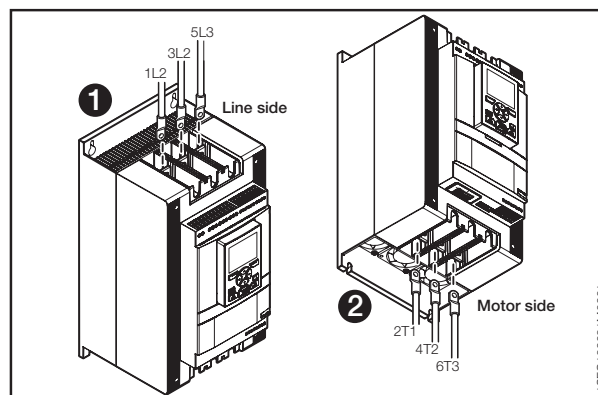
The harmonics are only harmful to the softstarter when it is not running a motor. To avoid problem with harmonics, a line contactor can be used to switch off the line voltage when the softstarter is not running a motor, see figures in **chapter 11.2.9 Softstarter in network with high harmonic disturbances**.



**Figure 2.1**  
In Line (1) and Inside Delta (2) connection



**Figure 2.2**  
Terminal connection clamps



**Figure 2.3**  
Terminal connection bars



### INFORMATION

Use only wires of the same dimension when you connect 2 wires to each terminal. (Possible for PSTX30...105 only).

4. Connect the control supply voltage (100-250V 50/60Hz) to terminal 1 and 2.
5. Connect the functional ground (terminal 22), to a ground point close to the Softstarter, see **Figure 2.4**.



### INFORMATION

The ground is not a protective ground, it is a functional ground. The maximum length of the ground cable is 0.5 m. Connect the ground cable to the installation plate where the Softstarter is attached. The installation plate must also be grounded.

### INFORMATION

Do not use functional ground in IT-networks, commonly found in for instance marine applications.

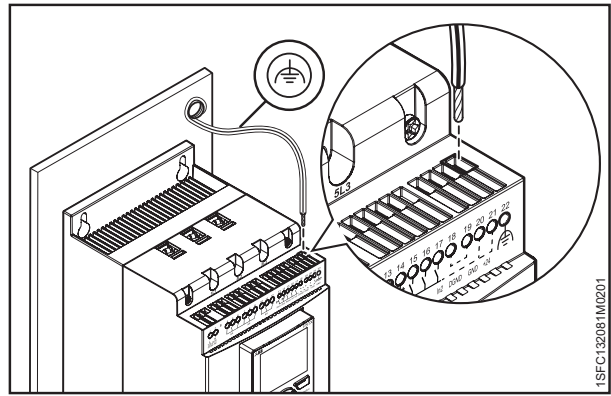
6. Look at the diagram, see **Figure 2.7**, and connect the start/stop circuits: terminal 13, 14, 18, 19 and 20/21, with the internal 24 V DC terminal. When you use internal 24 V DC (terminals 20 or 21), the terminals 18 and 19 must be connected to each other. For external control circuit voltage, see chapter **5.1.2.3 Start and Stop - terminals 13, 14, 18, 19, 20, 21**.



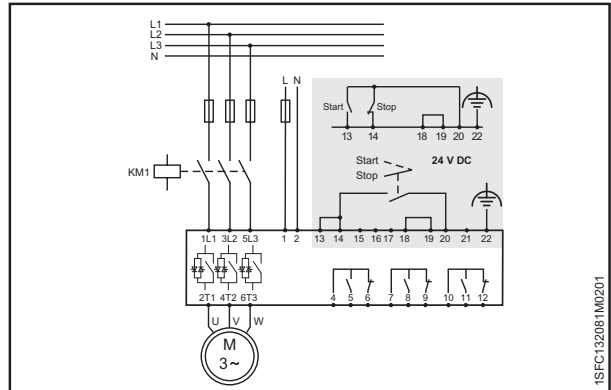
### WARNING

Use 24 V DC only when you connect terminal 13, 14, 15, 16 and 17. Other voltages can cause damage to the Softstarter and the warranty will no longer be valid. For more information about terminal 15, 16 and 17, see chapter **5.1.2.4 Programmable inputs - terminals 15, 16 and 17**.

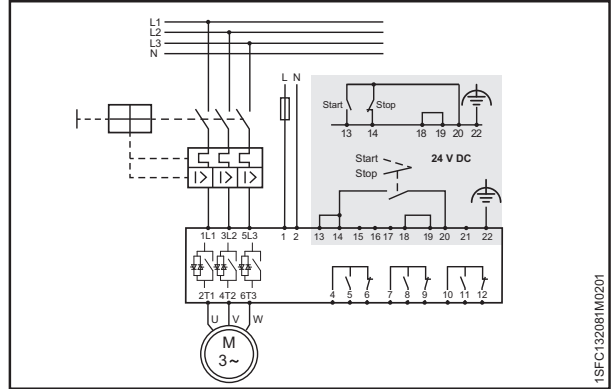
7. Connect terminals 4, 5, 6, 7, 8, 9, 10, 11 and 12 to use the signal output relays. These are potential-free contacts for maximum 250 V AC, 1.5 A AC-15 and 30 V DC, 5 A DC-12. See **Figure 2.5**.
8. Make sure that the operation voltage and control supply voltage agree with the Softstarter ratings.
9. Set the control supply voltage switch to ON.
10. The green Ready LED is constant lit if the following conditions are fulfilled:
  - Control supply voltage is detected
  - Mains three phase voltage is detected
  - Mains frequency is within range (40-72Hz)
  - Motor connection is detected
  - Phase sequence is detected
  - No events are active
  - Enable signal is active
  - If the max nbr of starts per hour function is enabled and set to stop manual or stop automatic, the remaining time to start counter (which can be shown in the HMI homeview) has to be zero
 Otherwise the ready LED is flashing, see **Figure 2.6**.



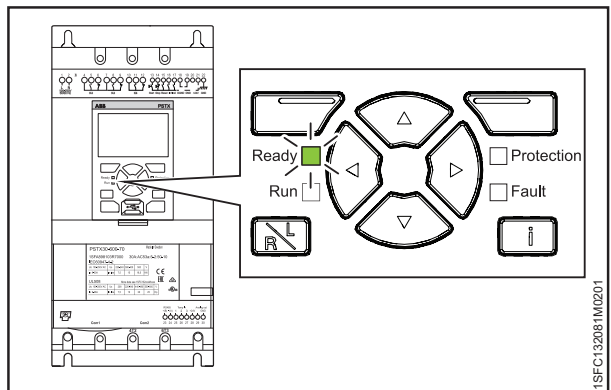
**Figure 2.4**  
Functional ground, terminal 22



**Figure 2.7**  
Circuit diagram (Fuse and contactor version)



**Figure 2.5**  
Circuit diagram (MCCB version)



**Figure 2.6**  
Flashing "Ready" LED

11. The language settings appear on the screen. Select your language and push the selection soft key "OK". The HMI now downloads the language data from the Softstarter. This can take some minutes. When this is done the HMI shows the Home view.
12. Configure applicable parameters as given in chapter **7 Functions** or use the assistants as given in chapter **2.2 Configuration**.

## 2.2 Configuration
















For a quick configuration of the Softstarter, use the Assistants menu.

The Assistants menus are divided into:

- **Basic set-up**
  - The Basic set-up menu is divided into 4 steps:
    1. Language
    2. Date and time
    3. Motor data
    4. System configuration
- **Application set-up**
  - The Application set-up is divided into 3 steps:
    1. Application set-up
    2. Keep/Change values
    3. Tune settings







### 2.2.1 Basic set-up

You see this set-up when you start the Softstarter. To disable this set-up, see step 6 below.

1. Find the Assistants menu by pushing  "Menu". Scroll to Assistants with the Navigation keys. Push  "Select" to enter the Assistants menu.
2. Scroll to the Basic set-up menu with the Navigation keys. Push  "Select" to enter the menu.
3. The Basic set-up starts with step 1 of 5, Language. Push  "Edit" to change language. Use the Navigation keys to select language and then push  "Save".
4. Push  to enter step 2(5), Date and time. Push  "Edit" and use the Navigation keys to edit date and time, then push  "Save".
5. Push  to enter step 3(5), Motor data. Push  "Edit" to change the Motor rated current le. Use the Navigation keys to change the value and then push  "Save".
6. Push  to enter step 4(5), System configuration. Here you can set if the Softstarter enters the Basic set-up at power on or not. Use the Navigation keys to select Yes or No and then push  "Save".
7. Push  to enter step 5(5) and then Push  "Done" to finish the Basic setup. For more settings, enter Application set-up.







## 2.2.2 Application set-up

1. Find the Assistants menu from the Home view by pushing  "Menu". Scroll to Assistants with the Navigation keys. Push  "Select" to enter the Assistants menu.
2. Scroll to the Application set-up menu with the Navigation keys and then enter the menu by pushing  "Select".
3. The Application set-up will start with step 1, Application type. Scroll to the appropriate application type and then push  "Select". For a full Application list, see chapter **7.25 Complete parameter list**.
4. Push  to enter step 2, Values. You can select "Keep actual values" or "Change to recommended values". Scroll to the selection of your choice and Push  "Select" to apply.



### WARNING!

Note that your saved parameter values are lost if you select "Change to recommended values".

5. Push  to enter step 3, Tune settings. In most cases the recommended values are sufficient, but sometimes fine tuning is necessary. For fine tuning, push  "Edit" and then use the navigation keys to set:
  - Start ramp time: 1 - 120s
  - Stop ramp time: 1 - 120s
  - Start ramp initial level: 10 - 99%
  - Stop ramp end level: 10 - 99%
  - Current limit level: 1.5 - 7.5 x I<sub>e</sub>
  - Start mode: Voltage ramp, Torque ramp or Full voltage start
  - Stop mode: No ramp, Voltage ramp, Torque ramp, Dynamic brake
6. Push  and then push  "Done" to finish the Application set-up. If necessary, fine tuning can also be done in the Parameters menu.

## 2.3 How to start/stop the motor



### WARNING

Dangerous voltage: Can cause death or serious injury. Always set the power switch to off and lock out all power to this device before you start to work on the equipment.



### WARNING

Approved personnel are allowed to install and make the electrical connection of the Softstarter in accordance with existing laws and regulations.



### WARNING!

Before you connect the Softstarters PSTX30... PSTX170 to the operation voltage for the first time, apply control supply voltage to open the bypass relays. (see 2.1 Connection). This is necessary to avoid an accidental start of the equipment while it is connected to operation voltage.



### INFORMATION

ABB personnel must obey the instructions in **ABB CISE 15.4**.

1. Set the operation voltage switch to ON.
2. To start the Softstarter from the keypad, push the R/L-key to select local control, then push the Start key on the keypad. Push Stop to stop the Softstarter
3. To start from hard wire control, push the R/L-key to select hard wire control, then push the remote Start key. Push Stop to stop the Softstarter.



# 3 Description

## 3.1 Overview

	18
3.1.1 Operation functions	18
3.1.2 Protection functions	18
3.1.2.1 User defined protection	19
3.1.3 Warning functions	19
3.1.4 Fault detection functions	19
3.1.5 Softstarter overview	20
3.1.6 Type designation	21
3.1.7 Environmental influence	21
3.1.8 Specifications	21

## 3.2 Technical data

	22
3.2.1 General	22
3.2.2 Technical data for external keypad	22
3.2.3 Semi-conductor fuses	22
3.2.4 Weights	22
3.2.5 Softstarter ratings	23
3.2.6 Dimensions	25

This chapter gives a description of the Softstarter in general, specifications and available components and spare parts.

## 3.1 Overview

The PSTX Softstarter has the latest technology for soft start and soft stop of squirrel cage motors. The Softstarter has multiple advanced motor protection features as standard.

3



### WARNING

If using the Rated Operational Voltage  $U_e$  (Phase /N) as source for Control Supply Voltage  $U_s$  make sure to not exceed  $U_s$  250V AC,50/60Hz.

### Bypass

Softstarter range PSTX30...1250 have integrated bypass components.

### User interface

The keypad on the front has Navigation keys, Selection soft keys, Start and Stop keys, Local or Remote key, Information key and a clear information screen. You can select 15 user languages.

You can control the Softstarter in 3 different ways:

- Hardwire inputs control
- Keypad control (either attached to the Softstarter front or detached and connected with the cable included)
- Fieldbus communication interface (by built in Modbus, Anybus module or the FieldBus Plug with adapter)

You can use only one type of control at the same time. Default selection is hardwire inputs control.



### INFORMATION

Keypad control has the highest priority and overrides all other control methods.

### Fans

The integrated fans for cooling will start after reaching TOR or Standby and run for 3 min.

Fans will never run during the transition from ramp to bypass or bypass to ramp.

The fans are temperature dependent

- on PSTX30...370 the fans will start when heatsink temp is over 60 °C and stop at 55 °C or after 30 min if the temp have not dropped >5 °C in TOR or idle.
- on PSTX470...1250 the fans will start when heatsink temp is over 50 °C and stop at 45 °C or after 30 min if the temp have not dropped >5 °C in TOR or idle.

For PSTX1050...1250 the fans will always run in TOR.

## 3.1.1 Operation functions

### Available functions are listed below:

- Voltage start ramp
- Voltage stop ramp
- Torque start ramp
- Torque stop ramp
- Full voltage start
- No ramp
- Stand-still brake
- Current limit
- Kick start
- Slow speed
- Motor heating
- Motor braking
- Sequence start
- Automatic restart

## 3.1.2 Protection functions

The PSTX Softstarter has protection functions to protect the Softstarter, motor and other equipment. All protections can have automatic reset or manual reset. You can enable or disable the protection.

### Available protections are listed below:

- Electronic overload protection
- Locked rotor protection
- Phase reversal protection
- Current imbalance protection
- Overvoltage protection
- Undervoltage protection
- Ground fault protection
- Voltage imbalance protection
- 24V output protection
- External thermal sensor - PT100 protection
- External thermal sensor - PTC protection
- Power factor underload protection
- Current underload protection
- User defined protection
- Too long current limit protection
- Bypass open protection
- Fieldbus failure protection
- Extension I/O failure protection
- HMI failure protection

- Max number of starts
- Frequency range protection
- Phase reversal protection
- Too long start time protection
- Auto restart protection
- IO Controller protection

### 3.1.2.1 User defined protection

You can use your own specified protection, with the programmable digital input and an external device/sensor. The protection operates when the input signal comes at high level (fieldbus or physical I/O).

### 3.1.3 Warning functions

The Softstarter has warning functions for potential risks, that operate before a protection function operates.

A warning cannot stop the Softstarter. A reset of a warning is not necessary.

You can change the warning level and other parameters for the warning functions. Warnings are stored in the event list.

#### Available warnings are listed below:

- Current imbalance warning
- Overvoltage warning
- Undervoltage warning
- EOL time-to-trip warning
- EOL warning
- Total Harmonic Distortion (THD) warning
- Voltage imbalance warning
- Power factor underload warning
- Current underload warning
- Locked rotor warning
- Thyristor overload warning
- Short circuit warning
- Number of starts warning
- Modbus configuration warning
- Phase loss warning
- Motor runtime warning
- Parameter storage warning

### 3.1.4 Fault detection functions

The Softstarter has a number of fault detection functions to signal malfunction at Softstarter, motor or power network level. The Softstarter identifies external and internal faults.

#### Available internal faults are listed below:

- Shunt fault
- Short circuit fault
- Open circuit thyristor fault
- Thyristor overload fault
- Heatsink overtemperature fault
- Unspecified fault
- Electronics failure
- Invalid Id

#### Available external faults are listed below:

- Phase loss fault
- Bad network fault
- Low supply voltage fault
- High current fault
- Faulty usage
- Faulty connection

### 3.1.5 Softstarter overview

Change the settings through Keypad and Fieldbus communication.

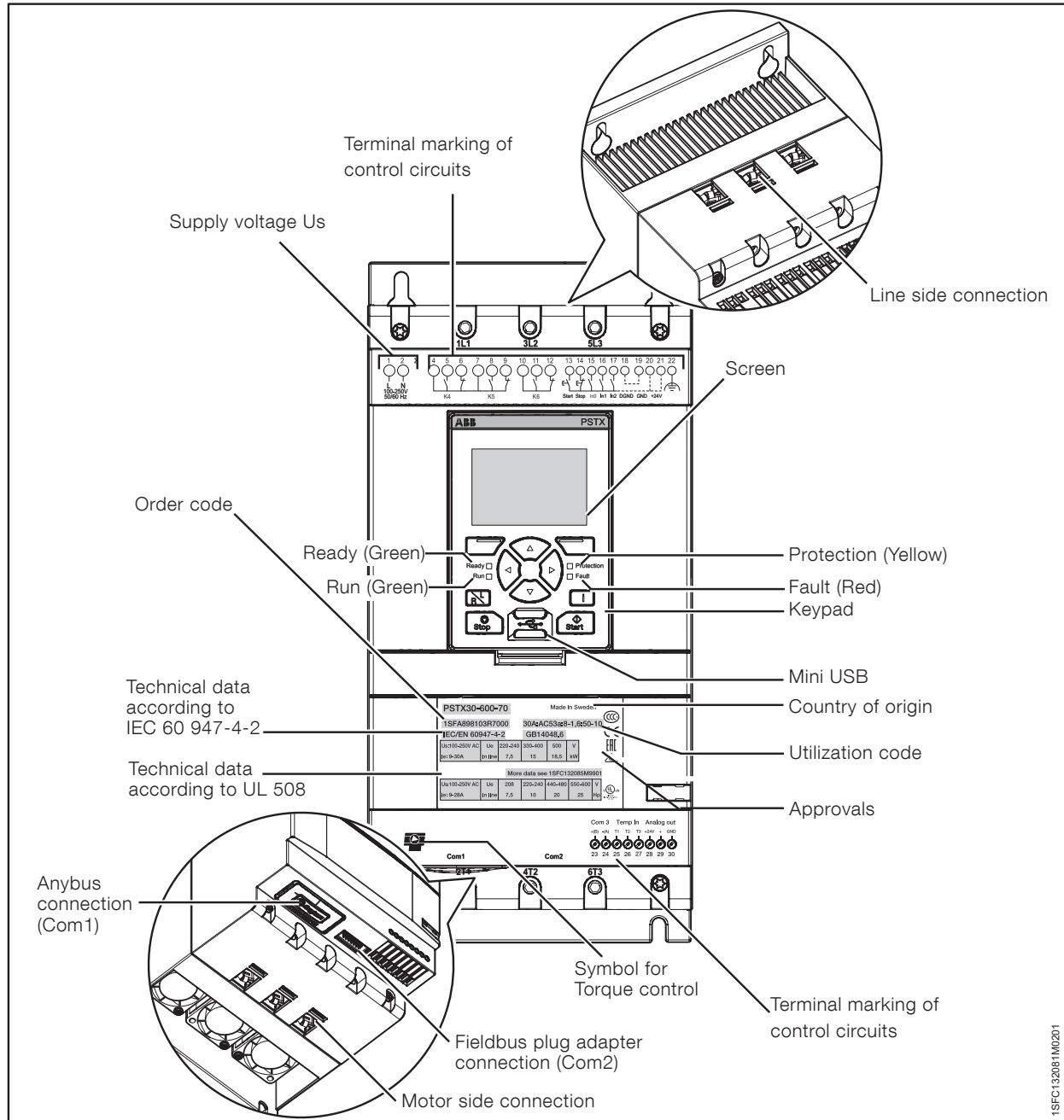
Use the keypad to change settings for each parameter alone or as a selection of default parameters for different applications.

Most parameters have one possible setting, but some parameters have extra settings for sequence start. The default parameter settings are stored in the unit for a reset to default.

When the fieldbus communication is selected, most parameters can also be changed from this interface.

Overview, See **Figure 3.1**.

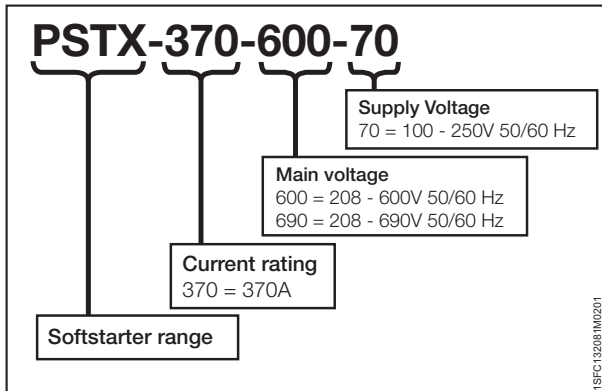
3



**Figure 3.1**  
Softstarter overview

Designation (i.e. PSTX370-600-70)	Description
PSTX	Softstarter type
370	Current rating 370 = 370A
600	Main voltage 600 = 208 - 600 V 50/60 Hz 690 = 208 - 690 V 50/60 Hz
70	Supply Voltage 70 = 100 - 250 V 50/60 Hz

Type designation, see **Figure 3.2**.



**Figure 3.2**  
Type designation

### 3.1.7 Environmental influence

The product is designed to reduce the effects on the environment during manufacturing and use of the product.

Most of the materials used are recyclable. Obey local laws when you handle and recycle the materials.

You can find further information about used material and recycling of the product at:

<https://solutions.abb/softstarters>

General data	Description	
Degree of protection: Main circuit	<b>PSTX30...105:</b> IP10	<b>PSTX142...1250:</b> IP00
Degree of protection: Supply and control circuit	<b>PSTX30...105:</b> IP20	<b>PSTX142...1250:</b> IP20
Operating position	Vertical at ± 30°	
Ambient temperature	<b>Storage:</b> -40 °C to +70 °C (-40 °F to 158 °F) <b>Operation:</b> -25 °C to +60 °C (-13 °F to 140 °F) <b>De-rating:</b> Above 40 °C (104 F) up to max. 60 °C (140 F) reduce the rated current with 0,8% per °C (0,44% per F).	
Altitude	1000 m (3281 ft.) above sea level without derating. 1000 - 4000 m (3281 - 13123 ft.) with derating 0,7%/100 m (0,22%/100ft)	
Pollution degree	3	
Relative humidity	5 - 95% (non condensing)	
Standards	IEC 60529 IEC 60947-1 IEC60947-4-2	
Standards UL	UL508	
PTC input	IEC 60947-8 Mark A detectors DIN 44081 and DIN 44082	
EMC	IEC 60947-4-2 Class A <b>1</b>	
Marine approvals	Speak to your ABB sales office	

**1** The Softstarter is designed for class A equipment. Use of the product in domestic environments can cause radio interference. If so, it can be necessary to use more mitigation procedures.

## 3.2 Technical data

### 3.2.1 General

**Table 3** General

General data	Description
24 V output	24 V ± 5% Max 250 mA
Rated insulation voltage, U <sub>i</sub>	600 V / 690 V
Rated operation voltage, U <sub>e</sub>	208-600 / 690 V, 50 / 60 Hz
Rated supply voltage, U <sub>s</sub>	100-250 V, 50 / 60 Hz
Thyristor Peak Inverse Voltage (PIV):	600 V version: 1600 V 690 V version: 1800 V
Voltage tolerance	+10% to -15%
Rated frequency	50 / 60 Hz
Frequency tolerances	± 10%
Rated impulse withstand voltage	6 kV Operation circuit 4 kV Control and supply circuit
Relay outputs	3 programmable
Number of controlled phases	3
Inputs	Start, stop, 3 programmable inputs (Digital I/O: In0, In1, In2), temperature sensor input.
Outputs	Relay outputs: K4 K5 K6.
Output relay performance	250 V AC, I <sub>th</sub> = 5A, I <sub>e</sub> = 1.5A (AC-15)
Analog output	4-20 mA, 0-20 mA, 0-10 V, 0-10 mA
PTC input	2825 ohm ± 20% switch off resistance 1200 ohm ± 20% switch on resistance
Cooling system	Fan
Recommended fuse	6 A Delayed
Control supply circuit	MCB use C characteristics
Communication	3 Fieldbus ports, Extension I/O
Communication protocols	DeviceNet / Profibus DP / Modbus / EtherNET/IP / Modbus TCP/ Profinet / BACnet IP / BACnet MS/TP / EtherCAT

### 3.2.3 Semi-conductor fuses



#### WARNING!

Semiconductor fuses must be used to keep the warranty on the thyristors.



#### INFORMATION

To achieve a type 2 coordination, semiconductor fuses must be used.

**Table 5** Fuses ratings and power losses

Type	Current range	Max power loss at rated I <sub>e</sub>	Max fuse rating - main circuit <sup>1)2)</sup>		Power requirements supply circuit Holding (VA) / Pull-in (VA)
			A	Type	
PSTX30	9.0...30.0	0,8	100	170M1567D	000 49/51
PSTX37	11.1...37.0	1,2	125	170M1568D	000 49/51
PSTX45	13.5...45.0	1,8	160	170M1569D	000 49/51
PSTX60	18.0...60.0	3,2	160	170M1569D	000 49/51
PSTX72	21.6...72.0	4,7	250	170M1571D	000 49/51
PSTX85	22.5...85.0	6,5	315	170M1572D	000 49/51
PSTX105	31.8...106.0	10	400	170M3819D	1 49/51
PSTX142	42.9...143.0	18	500	170M5810D	2 49/53
PSTX170	51.3...171.0	26	630	170M5812D	2 49/53
PSTX210	63.0...210.0	48	630	170M5812D	2 56/276
PSTX250	75.0...250.0	68	700	170M5813D	2 56/276
PSTX300	90.0...300.0	97	800	170M6812D	3 56/276
PSTX370	111.0...370.0	148	900	170M6813D	3 56/276
PSTX470	141.0...470.0	99	900	170M6813D	3 67/434
PSTX570	171.0...570.0	146	1000	170M6814D	3 67/434
PSTX720	216.0...720.0	78	1250	170M8554D	3 61/929
PSTX840	252.0...840.0	106	1500	170M6018D	3 61/929
PSTX1050 <sup>3)</sup>	315.0...1050.0	165	1800	170M6020D	3 68/929
PSTX1250 <sup>3)4)</sup>	375.0...1250.0	234	2000	170M6021D	3 68/929

<sup>1)</sup> For the supply circuit 6 A delayed, for MCB use C characteristics.

<sup>2)</sup> For inside delta connection the fuses shall be placed inside the delta. Contact ABB for more information.

<sup>3)</sup> 170M6019 with fuse rating 1600 A should be used for 690 V version.

<sup>4)</sup> For 690 V version, Bussmann fuses are only available for motors with rated current up to 1150 A.

You can find more detailed information at:

<http://applications.it.abb.com/SOC/>

### 3.2.2 Technical data for external keypad

**Table 4** Technical data for external keypad

Display	Display type
Status indicating LEDs	<b>Ready:</b> Green <b>Run:</b> Green <b>Protection:</b> Yellow <b>Fault:</b> Red
Ambient temperature	<b>Storage:</b> -25 °C to +70 °C (-13 °F to 158 °F) <b>Operation:</b> -25 °C to +60 °C (-13 °F to 140 °F)
Degree of protection	IP66
UL approval	Type 1 Type 4X Type 12
Marine approvals	Speak to your ABB sales office

### 3.2.4 Weights

**Table 6** Weights

Type	Weight in kg	Weight in lbs
PSTX30...105	6,1	13,5
PSTX142...170	9,6	21,2
PSTX210...370	12,7	27,9
PSTX470	25,5	55,1
PSTX570	27,5	59,5
PSTX720 ...840	46,2	101,4
PSTX1050	64,5	141,1
PSTX1250	65	143,3



### 3.2.5 Softstarter ratings

**PSTX30...1250** Temp ≤ + 40 °C (104 °F), 4 \* I<sub>e</sub> in 10 sec.

IEC	Softstarter type	Order number	le range	Motor power when connected In Line				Motor power when connected Inside Delta				Rated current I <sub>e</sub>	
				220-230V	380-400V	500V	690V	220-230V	380-400V	500V	690V	In Line	Inside Delta
				kW	kW	kW	kW	kW	kW	kW	kW	A	A
PSTX30...105	PSTX30-600-70	1SFA898103R7000	9-30A	7,5	15	18,5		12,5	25	30		30	52
	PSTX30-690-70	1SFA898203R7000	9-30A		15	18,5	25		25	30	45	30	52
	PSTX37-600-70	1SFA898104R7000	11,1-37A	9	18,5	22		15	30	37		37	64
	PSTX37-690-70	1SFA898204R7000	11,1-37A		18,5	22	30		30	37	55	37	64
	PSTX45-600-70	1SFA898105R7000	13,5-45A	12,5	22	25		25	37	45		45	76
	PSTX45-690-70	1SFA898205R7000	13,5-45A		22	25	37		37	45	59	45	76
	PSTX60-600-70	1SFA898106R7000	18-60A	15	30	37		30	55	75		60	105
	PSTX60-690-70	1SFA898206R7000	18-60A		30	37	55		55	75	90	60	105
	PSTX72-600-70	1SFA898107R7000	21,6-72A	18,5	37	45		37	59	80		72	124
	PSTX72-690-70	1SFA898207R7000	21,6-72A		37	45	59		59	80	110	72	124
	PSTX85-600-70	1SFA898108R7000	25,5-85A	22	45	55		40	75	90		85	147
	PSTX85-690-70	1SFA898208R7000	25,5-85A		45	55	75		75	90	132	85	147
PSTX142-170	PSTX105-600-70	1SFA898109R7000	31,8-106A	30	55	75		55	90	110		106	181
	PSTX105-690-70	1SFA898209R7000	31,8-106A		55	75	90		90	110	160	106	181
	PSTX142-600-70	1SFA898110R7000	42,9-143A	37	75	90		75	132	160		143	245
	PSTX142-690-70	1SFA898210R7000	42,9-143A		75	90	132		132	160	220	143	245
PSTX210...370	PSTX170-600-70	1SFA898111R7000	51,3-171A	45	90	110		90	160	200		171	300
	PSTX170-690-70	1SFA898211R7000	51,3-171A		90	110	160		160	200	257	171	300
	PSTX210-600-70	1SFA898112R7000	63-210A	59	110	132		102	184	250		210	360
	PSTX210-690-70	1SFA898212R7000	63-210A		110	132	184		184	250	315	210	360
PSTX470...570	PSTX250-600-70	1SFA898113R7000	75-250A	75	132	160		132	220	295		250	430
	PSTX250-690-70	1SFA898213R7000	75-250A		132	160	220		220	295	400	250	430
	PSTX300-600-70	1SFA898114R7000	90-300A	90	160	200		160	257	355		300	515
	PSTX300-690-70	1SFA898214R7000	90-300A		160	200	257		257	355	500	300	515
	PSTX370-600-70	1SFA898115R7000	111-370A	110	200	257		200	355	450		370	640
	PSTX370-690-70	1SFA898215R7000	111-370A		200	257	355		355	450	600	370	640
	PSTX470-600-70	1SFA898116R7000	141-470A	132	250	315		250	450	600		470	814
	PSTX470-690-70	1SFA898216R7000	141-470A		250	315	450		450	600	800	470	814
PSTX720...840	PSTX570-600-70	1SFA898117R7000	171-570A	160	315	400		295	540	700		570	987
	PSTX570-690-70	1SFA898217R7000	171-570A		315	400	560		540	700	960	570	987
	PSTX720-600-70	1SFA898118R7000	216-720A	200	400	500		355	710	880		720	1247
	PSTX720-690-70	1SFA898218R7000	216-720A		400	500	710		710	880	1200	720	1247
PSTX1050...1250	PSTX840-600-70	1SFA898119R7000	252-840A	250	450	600		450	800	1000		840	1455
	PSTX840-690-70	1SFA898219R7000	252-840A		450	600	800		800	1000	1400	840	1455
	PSTX1050-600-70	1SFA898120R7000	315-1050A	315	560	730		500	1000	1250		1050	1810
	PSTX1050-690-70	1SFA898220R7000	315-1050A		560	730	1000		1000	1250	1700	1050	1810
PSTX1250...1250	PSTX1250-600-70	1SFA898121R7000	375-1250A	400	710	880		670	1200	1500		1250	2160
	PSTX1250-690-70	1SFA898221R7000	375-1250A		710	880	1200		1200	1500	2000	1250	2160

1) All data for 40 °C ambient. Above 40 °C (104 F) up to max. 40 °C (140 F) reduce the rated current with 0,8% per degree C above 40 °C (0,44% per F).

**PSTX30...1250** Temp ≤ + 40 °C (104 °F), 4 \* Ie in 10 sec.

UL US	Softstarter type	Order number	Motor power when connected In Line				Motor power when connected Inside Delta				Rated current Ie	
			208V	220-240V	440-480V	550-600V	208V	220-240V	440-480V	550-600V	In Line	Inside Delta
			hp	hp	hp	hp	hp	hp	hp	hp	A	A
PSTX30...105	PSTX30-600-70	1SFA898103R7000	7,5	10	20	25	10	15	30	40	28	48
	PSTX30-690-70	1SFA898203R7000			20	25			30	40	28	48
	PSTX37-600-70	1SFA898104R7000	10	10	25	30	15	20	40	50	34	58
	PSTX37-690-70	1SFA898204R7000			25	30			40	50	34	58
	PSTX45-600-70	1SFA898105R7000	10	15	30	40	20	25	50	60	42	72
	PSTX45-690-70	1SFA898205R7000			30	40			50	60	42	72
	PSTX60-600-70	1SFA898106R7000	20	20	40	50	30	40	75	100	60	103
	PSTX60-690-70	1SFA898206R7000			40	50			75	100	60	103
	PSTX72-600-70	1SFA898107R7000	20	25	50	60	30	40	75	100	68	117
	PSTX72-690-70	1SFA898207R7000			50	60			75	100	68	117
	PSTX85-600-70	1SFA898108R7000	25	30	60	75	40	50	100	125	80	138
	PSTX85-690-70	1SFA898208R7000			60	75			100	125	80	138
PSTX142-170	PSTX105-600-70	1SFA898109R7000	30	40	75	100	60	60	150	150	104	180
	PSTX105-690-70	1SFA898209R7000			75	100			150	150	104	180
	PSTX142-600-70	1SFA898110R7000	40	50	100	125	75	75	150	200	130	225
	PSTX142-690-70	1SFA898210R7000			100	125			150	200	130	225
PSTX210...370	PSTX170-600-70	1SFA898111R7000	50	60	125	150	75	100	200	250	169	292
	PSTX170-690-70	1SFA898211R7000			125	150			200	250	169	292
	PSTX210-600-70	1SFA898112R7000	60	75	150	200	100	125	250	300	192	332
	PSTX210-690-70	1SFA898212R7000			150	200			250	300	192	332
PSTX470...570	PSTX250-600-70	1SFA898113R7000	75	100	200	250	150	150	350	450	248	429
	PSTX250-690-70	1SFA898213R7000			200	250			350	450	248	429
	PSTX300-600-70	1SFA898114R7000	100	100	250	300	150	200	450	500	302	523
	PSTX300-690-70	1SFA898214R7000			250	300			450	500	302	523
	PSTX370-600-70	1SFA898115R7000	125	150	300	350	200	250	500	600	361	625
	PSTX370-690-70	1SFA898215R7000			300	350			500	600	361	625
PSTX720...840	PSTX470-600-70	1SFA898116R7000	150	200	400	500	250	300	600	700	480	830
	PSTX470-690-70	1SFA898216R7000			400	500			600	700	480	830
	PSTX570-600-70	1SFA898117R7000	200	200	500	600	300	350	700	800	590	1020
	PSTX570-690-70	1SFA898217R7000			500	600			700	800	590	1020
PSTX1050...1250	PSTX720-600-70	1SFA898118R7000	250	300	600	700	400	500	1000	1200	720	1240
	PSTX720-690-70	1SFA898218R7000			600	700			1000	1200	720	1240
	PSTX840-600-70	1SFA898119R7000	300	350	700	800	500	600	1200	1500	840	1450
	PSTX840-690-70	1SFA898219R7000			700	800			1200	1500	840	1450
PSTX1050...1250	PSTX1050-600-70	1SFA898120R7000	400	450	900	1000	600	700	1500	1900	1062	1830
	PSTX1050-690-70	1SFA898220R7000			900	1000			1500	1900	1062	1830
	PSTX1250-600-70	1SFA898121R7000	400	500	1000	1200	800	900	1800	2000	1250	2160
	PSTX1250-690-70	1SFA898221R7000			1000	1200			1800	2000	1250	2160

4 \* Ie in 10 sec

Ordering data according to UL (40°C ambient)

### 3.2.6 Dimensions

#### PSTX30...105

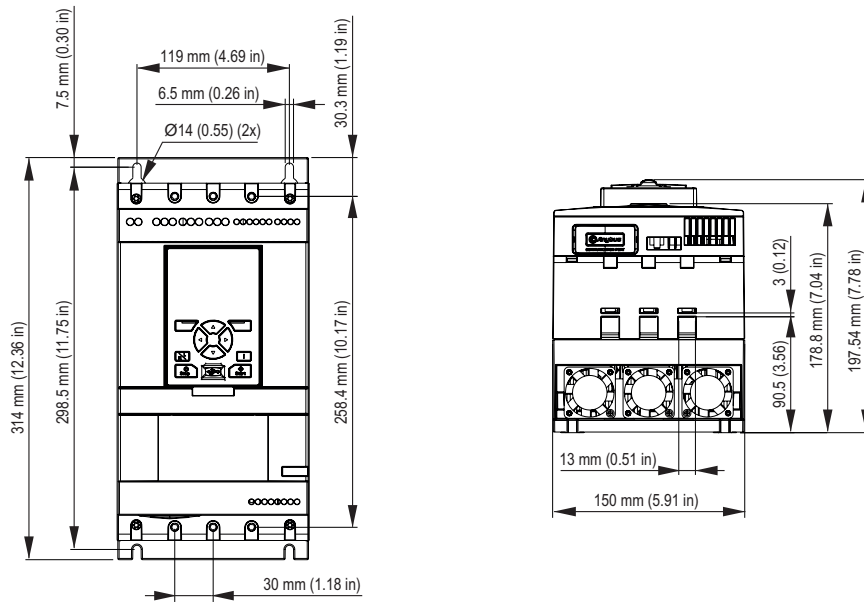


Figure 3.3  
Dimensions PSTX30...105

#### PSTX142...170

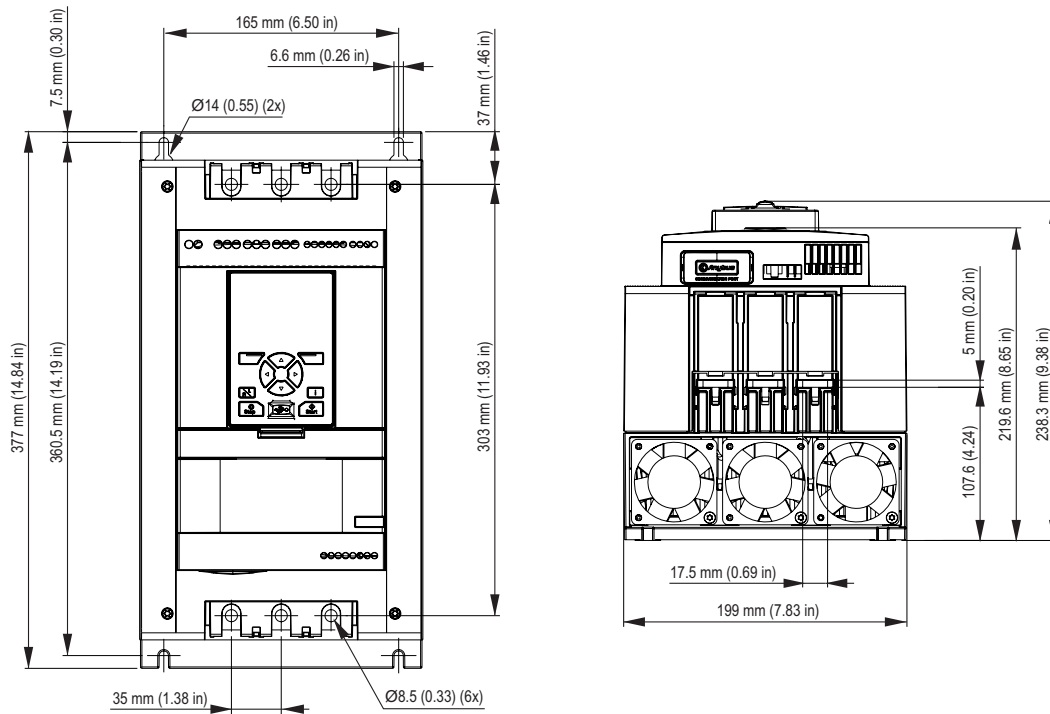


Figure 3.4  
Dimensions PSTX142...170

### PSTX210...370

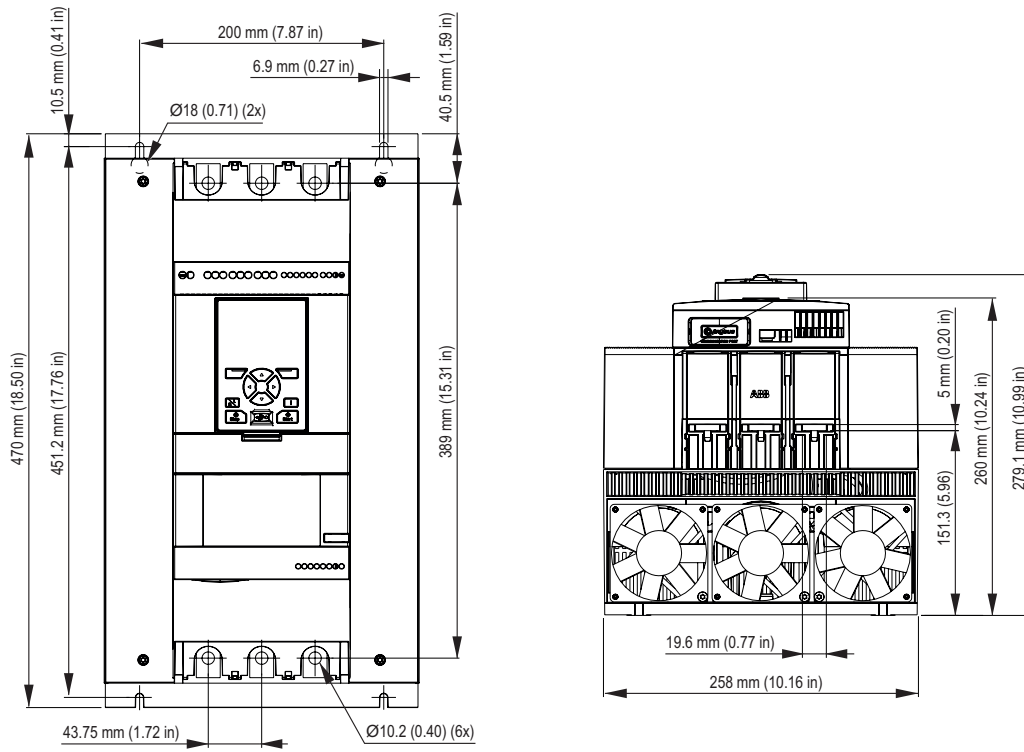


Figure 3.5  
Dimensions PSTX210...370

### PSTX470...570

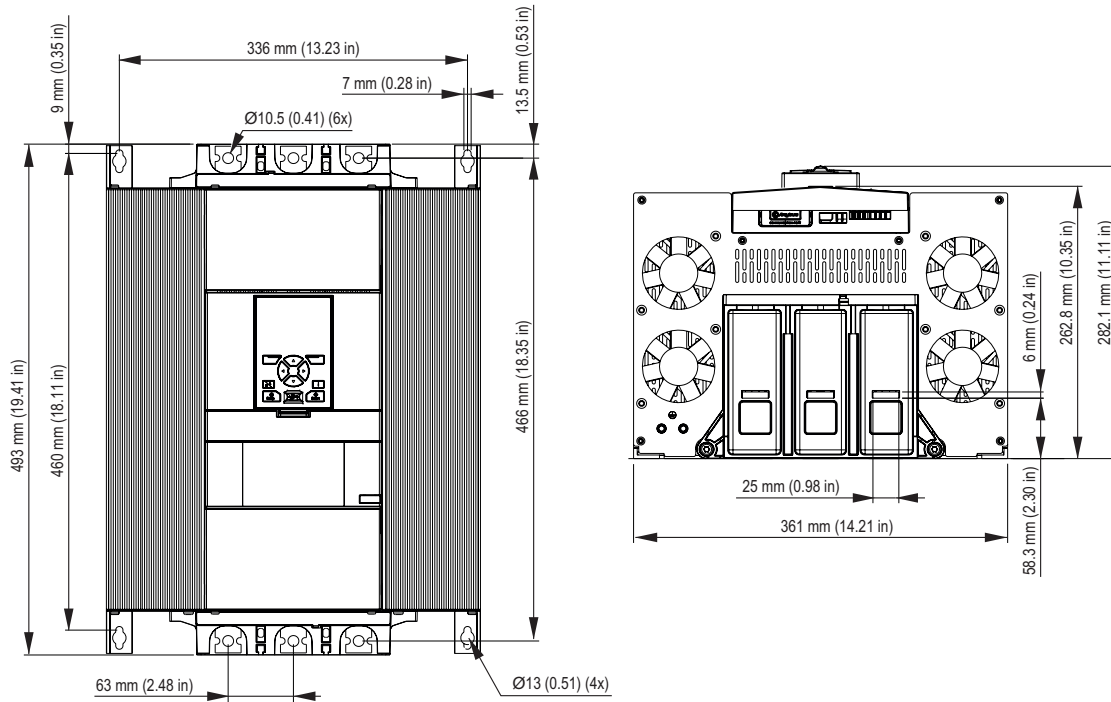
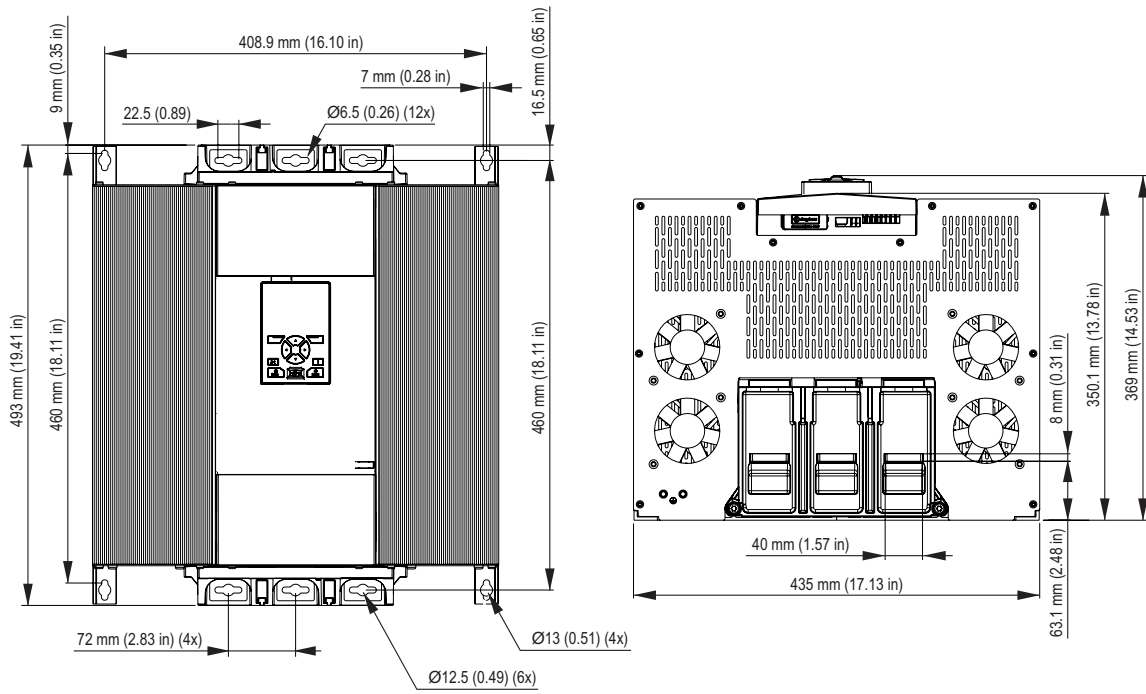


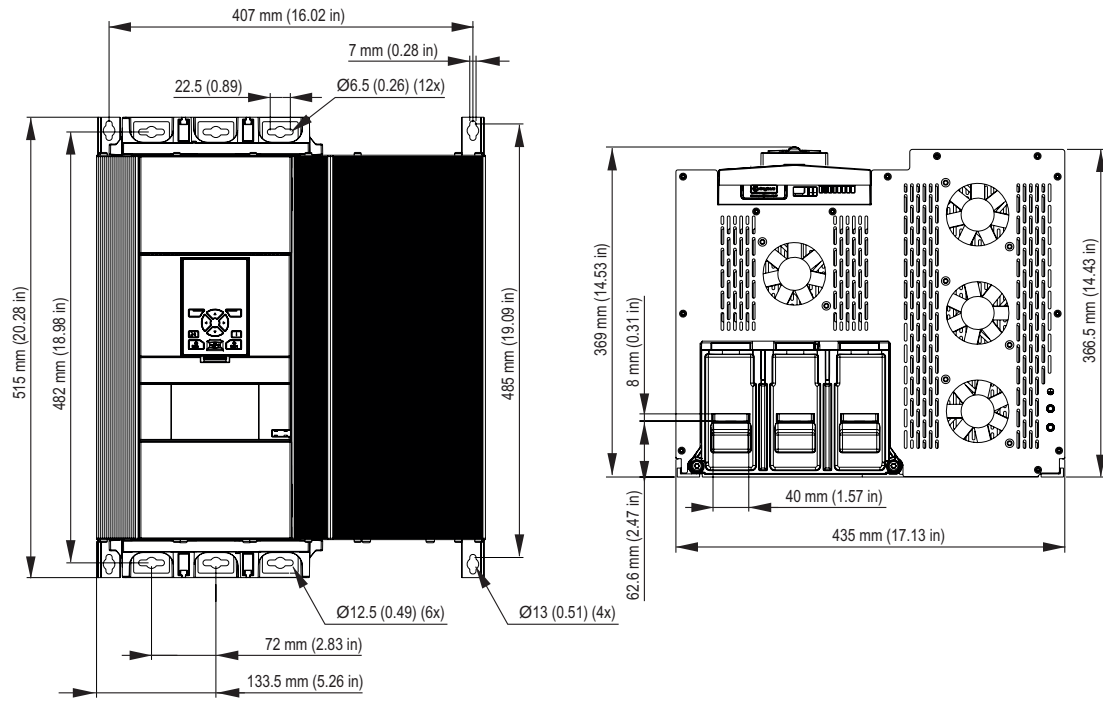
Figure 3.6  
Dimensions PSTX470...570

**PSTX720...PSTX840**



**Figure 3.7**  
Dimensions PSTX720..840

**PSTX1050**



**Figure 3.8**  
Dimensions PSTX1050

PSTX1250

3

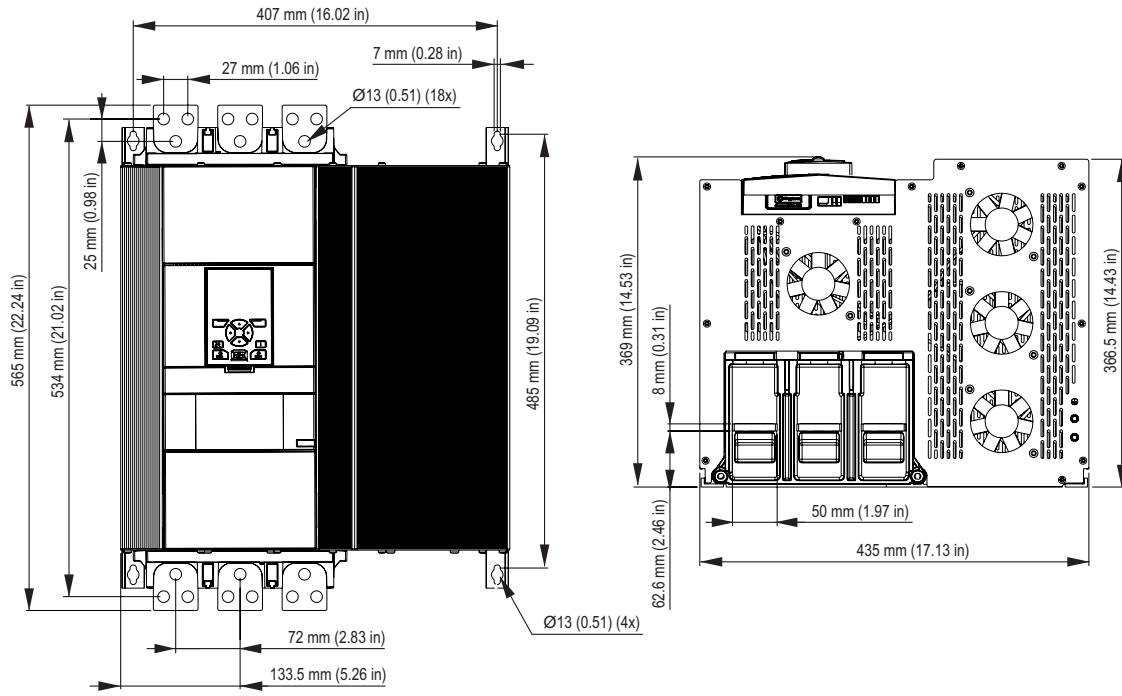


Figure 3.9  
Dimensions PSTX1250







# 4 Installation

## 4.1 Receive, unpack and examine

32

## 4.2 Install

33

4.2.1 Lifting the Softstarter ..... 33

4.2.2 Minimum distance to wall/front ..... 33

4.2.3 Minimum enclosure dimensions ..... 34

4.2.4 Maximum installation angle ..... 34

4.2.5 Dimensions and drilling plan ..... 34

4.2.6 Movable keypad ..... 34

4.2.6.1 Installation Movable HMI ..... 35

4

This chapter contains instructions to receive and install the Softstarter.



**WARNING**

If you do not obey these instructions, it can cause the Softstarter to overheat or not operate correctly.

**4.1 Receive, unpack and examine**



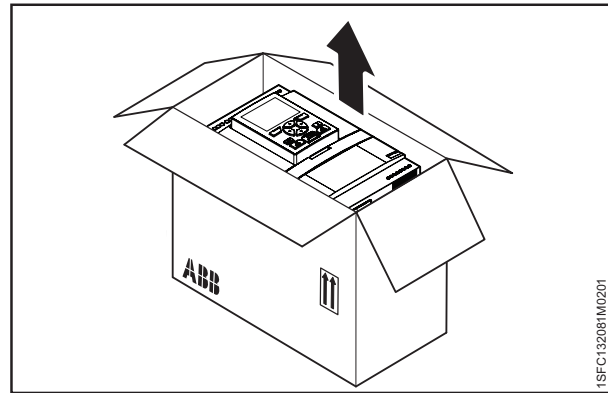
**WARNING**

Risk of damage to property. Make sure that no liquids, dust or conductive parts can go into the Softstarter.

4

Make sure that the package is placed with the correct side up, see **Figure 4.1**.

- Remove the transport casing.
- Make sure that the order code agrees with the delivery documents.
- Make sure that all items are included, see the delivery note. See **Table 1 Delivery note**.
- Examine the Softstarter and the packaging. In case of damages, speak to the transport company or the ABB reseller/Office immediately.
- Keep the Softstarter in its packaging until installation.



**Figure 4.1**  
Receiving, unpacking and checking

**Table 1** Delivery note

Softstarter type	Items included with the Softstarter
PSTX30...105	<ul style="list-style-type: none"> <li>• 1SFB262001D1000 – HMI Mounting Kit</li> <li>• 1SFC132082M9901 – PSTX Short Form Manual</li> </ul>
PSTX142...170	<ul style="list-style-type: none"> <li>• 1SFB262001D1000 – HMI Mounting Kit</li> <li>• 1SFC132082M9901 – PSTX Short Form Manual</li> <li>• 1SFA899221R1002 – Terminal Kit # PSLE-185</li> </ul>
PSTX210...370	<ul style="list-style-type: none"> <li>• 1SFB262001D1000 – HMI Mounting Kit</li> <li>• 1SFC132082M9901 – PSTX Short Form Manual</li> <li>• 1SFA899221R1003 – Terminal Kit # PSLE-300</li> </ul>
PSTX470...570	<ul style="list-style-type: none"> <li>• 1SFB262001D1000 – HMI Mounting Kit</li> <li>• 1SFC132082M9901 – PSTX Short Form Manua</li> <li>• 1SFA899221R1004 - Terminal Kit # PSLE-460l</li> <li>• 2191323-A - Mounting kit</li> </ul>
PSTX720...840	<ul style="list-style-type: none"> <li>• 11SFB262001D1000 – HMI Mounting Kit</li> <li>• 1SFC132082M9901 – PSTX Short Form Manual</li> <li>• 1SFA899221R1005 - Terminal Kit#PSLE-750</li> <li>• 2191323-A - Mounting kit</li> </ul>
PSTX1050...1250	<ul style="list-style-type: none"> <li>• 11SFB262001D1000 – HMI Mounting Kit</li> <li>• 1SFC132082M9901 – PSTX Short Form Manual</li> <li>• 1SFA899221R1005 - Terminal Kit#PSLE-750</li> <li>• 2191323-A - Mounting kit</li> </ul>

## 4.2 Install

The Softstarters are available in different physical sizes and all of them should be mounted with M6 bolts, or bolts with the same dimension and strength.

### 4.2.1 Lifting the Softstarter

Use lifting equipment to install the models PSTX470...1250. See chapter **3.2.4 Weights**, for weights. You can install the PSTX30...370 without lifting equipment

### 4.2.2 Minimum distance to wall/front



#### WARNING

Risk of damage to property. Make sure that no liquids, dust or conductive parts enter the Softstarter.



#### WARNING

If you do not obey these instructions, this can cause the Softstarter to overheat or not operate correctly.

For sufficient cooling, install the Softstarter vertically. Perfect blockage of the airways, see **Figure 4.2**.

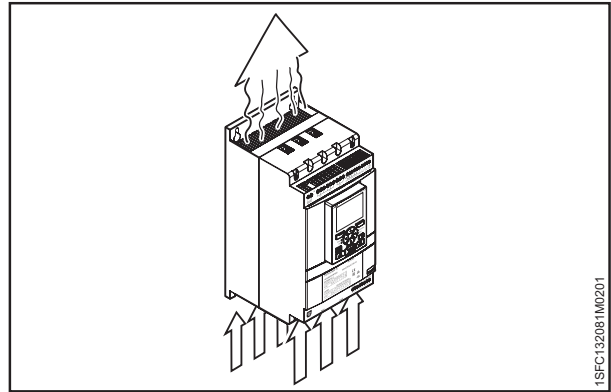


#### INFORMATION

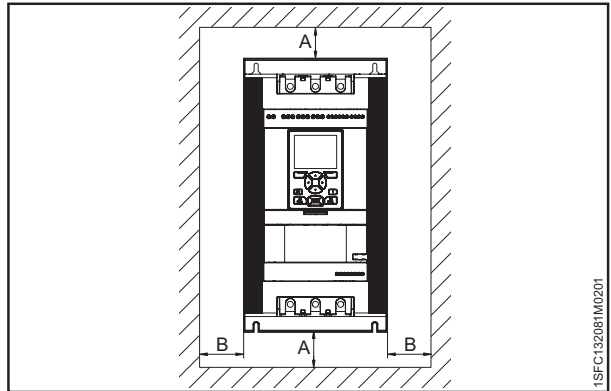
Make sure that the distances to the surrounding walls are sufficient. For the minimum distance to front and wall, see **Figure 4.3**, **Figure 4.4** and **Table 2**.

**Table 2** Minimum distance to wall/front

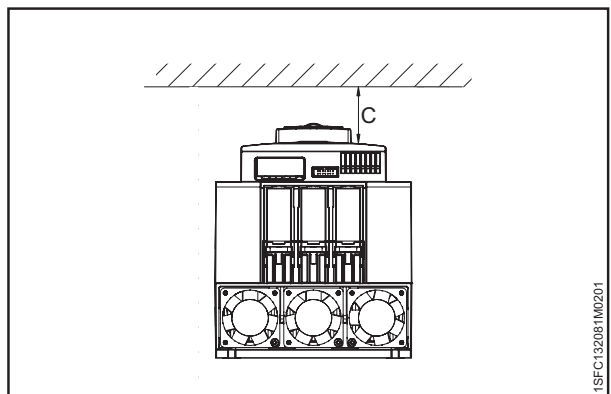
Softstarter type	A (mm)	B (mm)	C (mm)	A (in)	B (in)	C (in)
PSTX30...105	100	10	35	3.94	0.39	1.38
PSTX142...170	100	10	35	3.94	0.39	1.38
PSTX210...370	100	10	35	3.94	0.39	1.38
PSTX470...570	150	15	35	5.905	0.590	1.38
PSTX720...840	150	15	35	5.905	0.590	1.38
PSTX1050...1250	150	15	35	5.905	0.590	1.38



**Figure 4.2**  
Flow of air for cooling purpose



**Figure 4.3**  
Minimum distances to wall



**Figure 4.4**  
Minimum distances to front

### 4.2.3 Minimum enclosure dimensions

In applications where the Softstarter is installed in an enclosure, use these minimum enclosure dimensions. See **Figure 4.5** and **Table 3** and **4**.

**Table 3** Minimum enclosure dimensions (IEC)

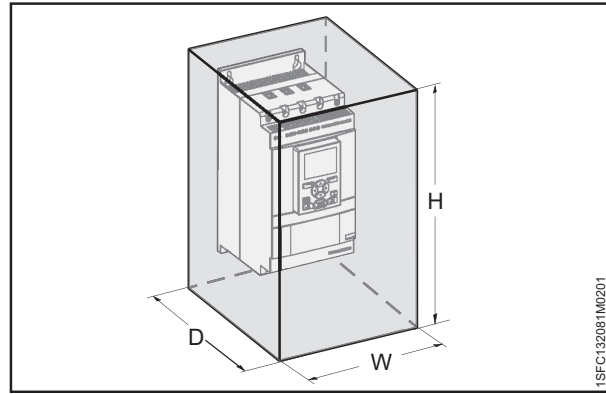
IEC	Minimum enclosure dimensions		
	H (mm)	W (mm)	D (mm)
PSTX30...105	610	508	305
PSTX142...170	762	610	305
PSTX210...370	914	762	305
PSTX470...570	1219	914	405
PSTX720...840	1524	914	405
PSTX1050...1250*	1524	914	405

\*) PSTX1250 Recommended fan capacity 230m3/h

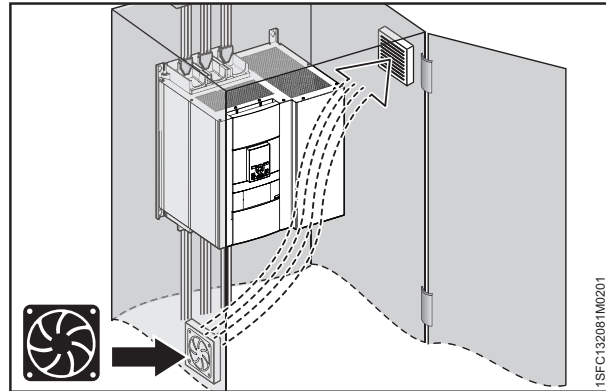
**Table 4** Minimum enclosure dimensions (UL)

Softstarter type	Minimum enclosure dimensions			
	H (in)	W (in)	D (in)	Min number of latches
PSTX30...105	24	20	10	2
PSTX142...170	30	24	12	4
PSTX210...370	30	24	12	4
PSTX470...570	48	36	16	8
PSTX720...840	60	36	16	8
PSTX1050...1250*	60	36	16	8

\*) PSTX1250 Recommended fan capacity 230m3/h



**Figure 4.5**  
Minimum enclosure size



**Figure 4.6**  
Airflow

### 4.2.4 Maximum installation angle

**i** Make sure that the distances to the walls are sufficient. Use the installation angle given in **Figure**.

### 4.2.5 Dimensions and drilling plan

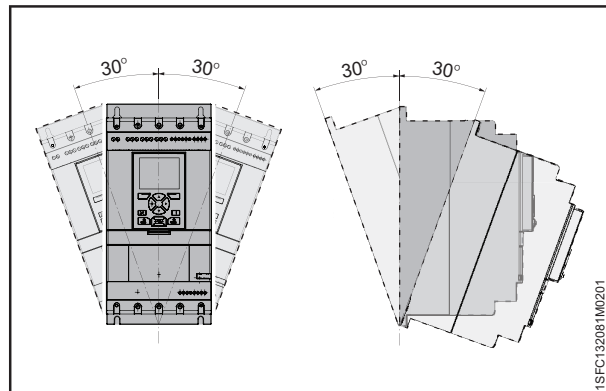
For dimensions and drilling plan see chapter **3.2.6 Dimensions**. Drilling plan is also printed on the box.

**⚠ WARNING**  
Risk of damage to property. Ensure that no liquids, drilling particles, dust or conductive parts enter the Softstarter.

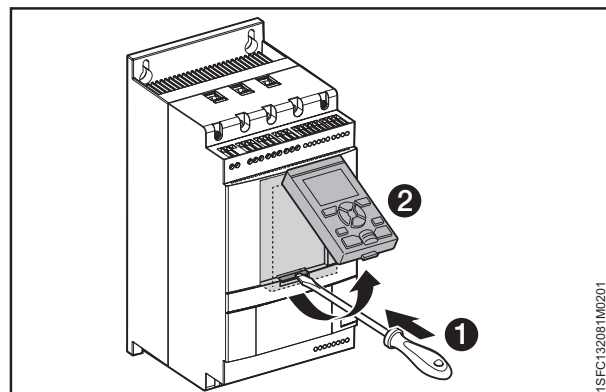
**⚠ WARNING**  
When the enclosure is too small and/or you do not obey the instructions, the Softstarter can overheat or not operate correct.

### 4.2.6 Movable keypad

If you remove the PSTX keypad, connect it with the included 3 meter cable for serial communication and power supply. Connect the cable to the network port on the front of the Softstarter. To remove the keypad, push the lock with a screwdriver, see **1** and **2** in **Figure 4.8**.



**Figure 4.7**  
Maximum mounting angle



**Figure 4.8**  
Detach the keypad

#### 4.2.6.1 Installation Movable HMI



##### INFORMATION

Do not use shielded RJ45 cables. Use a cable length of maximum 3m to reduce distortion of the communication.



##### INFORMATION

The Softstarter HMI is IP66 approved when installed on the enclosure door.

You can use the movable HMI to copy parameters from one Softstarter to another during commissioning (temporarily handheld).

Included with the Softstarter comes:

- Rubber gasket
- Plastic screw-nut
- RJ45 Network cable

- To remove the movable HMI from the Softstarter, loosen the plastic latch below the movable HMI, see **1** and **2** in **Figure 4.9**.
- Drill a hole where to attach the movable HMI. Maximum dimension of the hole is  $\text{Ø}26$  ( $\text{Ø} 1.02''$ ), see **1** in **Figure 4.9**. Put the rubber packing around the threaded network connector on the movable HMI, see **2** in **Figure 4.9**. Push the threaded network connector through the drilled hole. See **3** in **Figure 4.9**. Fasten the plastic screw-nut on the threaded network connector, with 2 Nm (17.7 lb/in).
- Remove the RJ45 plug see **4**. Connect one end of the network cable to the network port on the front of the Softstarter **5** in **Figure 4.10**.
- Connect the other end of the network cable to the network port on the back of the movable HMI, see **6** in **Figure 4.11**.
- Make sure that the network cable is properly inserted into the 2 ports. Prevent the rest of the cable to get caught between the door, see **7** in **Figure 4.12**. Close the door of the enclosure and set the operation voltage switch to ON. Make sure that the external HMI works.

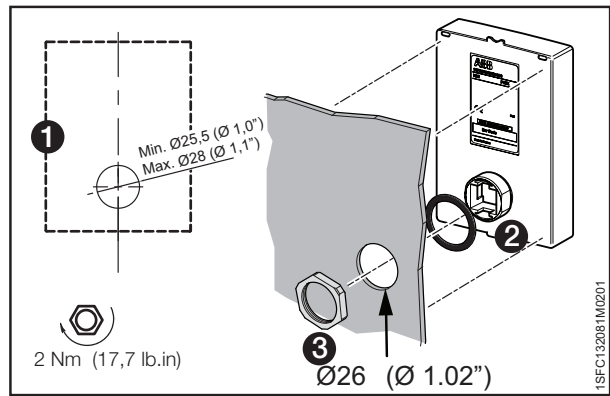


Figure 4.9

Drill a hole for the detachable keypad

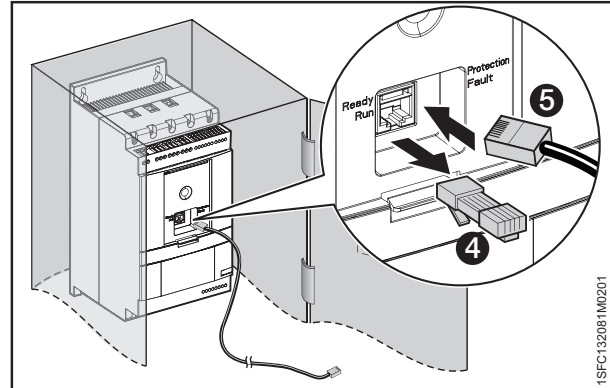


Figure 4.10

Connect one end of the network cable

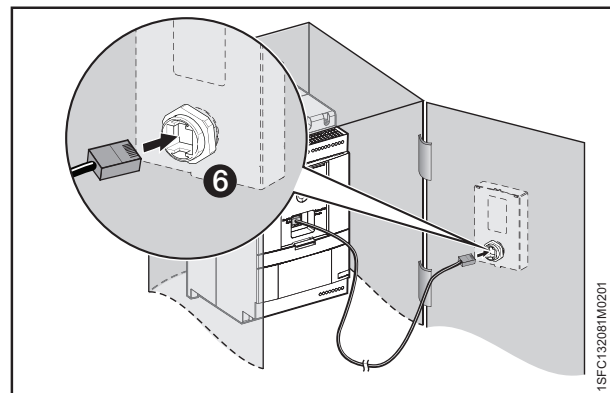


Figure 4.11

Connect the other end of the network cable

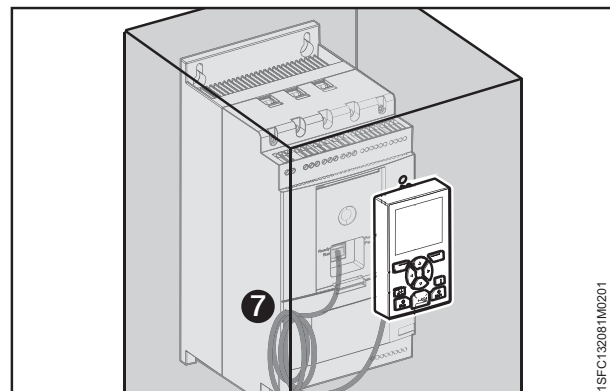


Figure 4.12

Roll the rest of the hanging cable

4

# 5 Connection

## 5.1 Electrical connection

	38
5.1.1 Main circuit	38
5.1.1.1 Tightening torques and cable dimensions	39
5.1.1.2 Softstarter connections	39
5.1.1.3 Protective Earth	40
5.1.2 Control supply and control circuit	41
5.1.2.1 Control supply voltage - terminals 1 and 2	41
5.1.2.2 Functional ground - terminal 22	41
5.1.2.3 Start and Stop - terminals 13, 14, 18, 19, 20, 21	42
5.1.2.4 Programmable inputs - terminals 15, 16 and 17	44
5.1.2.5 Programmable inputs (Sequence start)	45
5.1.2.6 Programmable output relay - K4, terminals 4, 5 and 6	46
5.1.2.7 Programmable output relay - K5, terminals 7, 8 and 9	46
5.1.2.8 Programmable output relay - K6, terminals 10, 11 and 12	46
5.1.2.9 Close bypass PSTX470...PSTX1250	47
5.1.2.10 Modbus RTU	47
5.1.2.11 Temperature sensor input	48
5.1.2.12 Analog output	49
5.1.3 Extension I/O	50

This chapter gives a description of the electrical connections and connections for communication devices.



### WARNING

Installation of electrical connections must be done by authorized personnel. Obey all laws and regulations.



### WARNING

Dangerous voltage. Can cause death or serious injury. Always set the power switch to off and lock out all power to this device before you start to work on the equipment.



### WARNING!

Before you connect the Softstarters PSTX30...PSTX170 to the operation voltage for the first time, apply control supply voltage to open the bypass relays. (see 2.1 Connection). This is necessary to avoid an accidental start of the equipment while it is connected to operation voltage.



### INFORMATION

ABB personnel must obey the instructions in **ABB CISE 15.4**.

5

For basic connection, see chapter **2 Quick start**.  
For wiring diagrams, see chapter **11 Wiring and application diagrams**.

Softstarters PSTX30...PSTX1250 can be connected In Line, see **1** **Figure 5.1**, and Inside Delta, see **2** **Figure 5.1**. Use wire connection for PSTX30...105 see **Figure 5.2** Terminal connection for PSTX142...1250 see **Figure 5.3**.

- Connect the line side to terminals 1L1, 3L2, 5L3, see **1** in **Figure 5.2** and **Figure 5.3**.
- Connect the motor to terminals 2T1, 4T2, 6T3 on the motor side, see **2** in **Figure 5.2** and **Figure 5.3**.

The terminal marking is printed on the front of the Softstarter. For tightening torques and cable thickness, see chapter **5.1.1.1 Tightening torques and cable dimensions**.

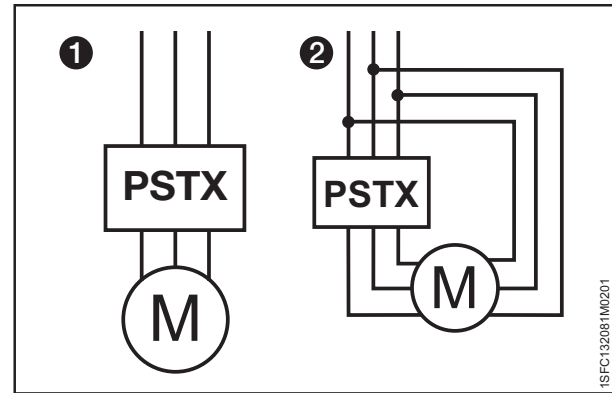


Figure 5.1

In line (1) and inside delta (2) connection

## 5.1 Electrical connection



### WARNING

Capacitors for power factor compensation are not permitted in between the Softstarter and the motor, because this can cause current peaks which can burn the thyristors in the Softstarter. If you must use such capacitors, connect them on the line side of the Softstarter.

### 5.1.1 Main circuit



### INFORMATION

From the softstarter perspective, there are no specific restrictions when it comes to motor cable lengths except from the implications that comes from using long cables which include the quality of the voltage, the current and the phase angle between them. An incorrect phase angle may reduce the efficiency of the motor and long cables can reduce the phase angle so that the load becomes capacitive.

PSTX can control a motor as long as the load is inductive or resistive, but not capacitive. The other thing to consider is the voltage drop that may occur when using long motor cables. A voltage drop can impact both the current draw and the motor power.

The maximum allowed voltage drop should be 5%.

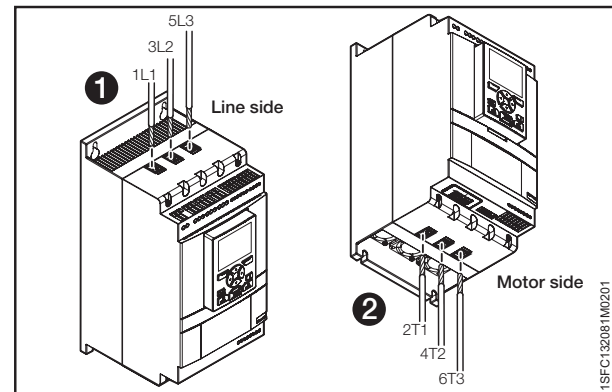


Figure 5.2

Clamp connection

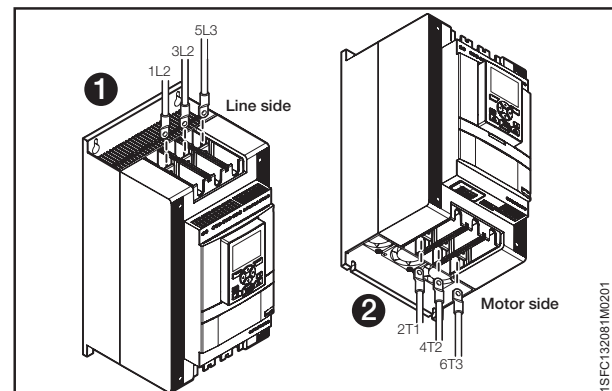


Figure 5.3

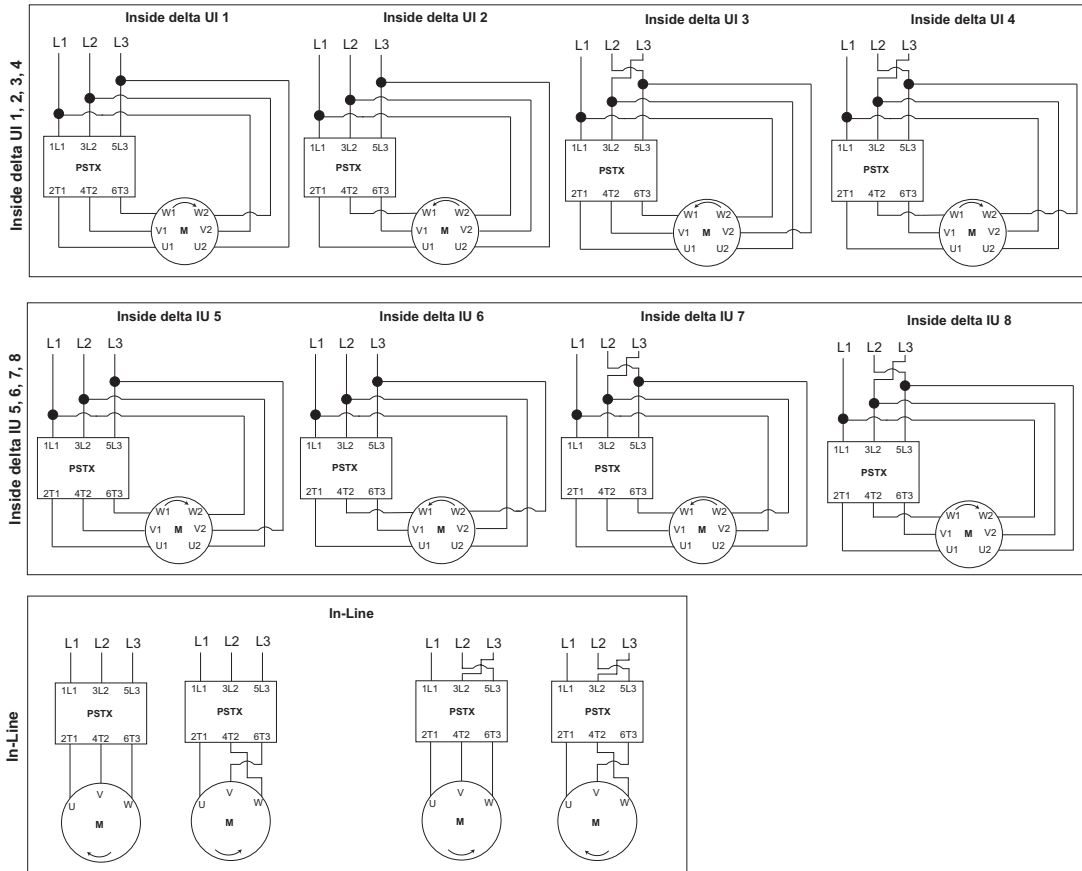
Terminal connection bar



### 5.1.1.1 Tightening torques and cable dimensions

<p>PSTX30...105</p>	<p>M8</p> <p>8 Nm - 71 lb.in</p>	<p>Using built-in clamp</p> <p>AWG6 .. 2/0 Cu 75 °C only</p> <p>Rigid: 10 ... 95 mm<sup>2</sup> Flexible: 10 ... 70 mm<sup>2</sup> Rigid/flexible: 2x6 ... 2x35 mm<sup>2</sup></p>		
<p>PSTX142...170</p>	<p>11/6-16 UNF-2A</p> <p>275 lb.in</p>	<p>Using cable clamp/lug</p> <p>ATK185: AWG4 to 300kcmil Cu 75 °C only</p>	<p>M8</p> <p>18 Nm - 160 lb.in</p>	<p>Using lug/bar</p> <p>max 24 mm (0.945 in)</p> <p>max 24 mm (0.945 in)</p>
<p>PSTX210...370</p>	<p>3/4-16 UNF-2A</p> <p>375 lb.in</p>	<p>Using cable clamp/lug</p> <p>ATK300: AWG4 to 400kcmil ATK300/2: AWG4 to 500kcmil or 2xAWG4 to 2x500kcmil Cu 75 °C only</p>	<p>M10</p> <p>28 Nm - 240 lb.in</p>	<p>Using lug/bar</p> <p>max 30 mm (1.181 in)</p> <p>max 32 mm (1.260 in)</p>
<p>PSTX470...570</p>	<p>5/8-18 UNF-2A</p> <p>275 lb.in</p>	<p>Using cable clamp/lug</p> <p>ATK580/2: 2xAWG2/0 to 2x500 kcmil ATK750/3: 3xAWG2/0 to 3x500 kcmil CU 75 °C only</p>	<p>M10</p> <p>35 Nm - 310 lb.in</p>	<p>Using lug/bar</p> <p>max 47 mm (1.85 in)</p> <p>max 47 mm (1.850 in)</p>
<p>PSTX720...840</p>	<p>3/4-16 UNF-2A</p> <p>375 lb.in</p>		<p>M12</p> <p>45 Nm - 398 lb.in</p>	<p>Using lug/bar</p> <p>max 50 mm (1.969 in)</p> <p>max 50 mm (1.969 in)</p>
<p>PSTX1050...1250</p>	<p>M12</p> <p>45 Nm - 398 lb.in</p>	<p>Using bars</p> <p>1x 40 mm (1.57 in)</p> <p>+ 2x 50 mm (1.96 in)</p> <p>5 mm (0.19 in)</p> <p>6 mm (0.23 in)</p>	<p>M12</p> <p>45 Nm - 398 lb.in</p>	<p>Using lug/bar</p> <p>max 50 mm (1.969 in)</p> <p>max 50 mm (1.969 in)</p>

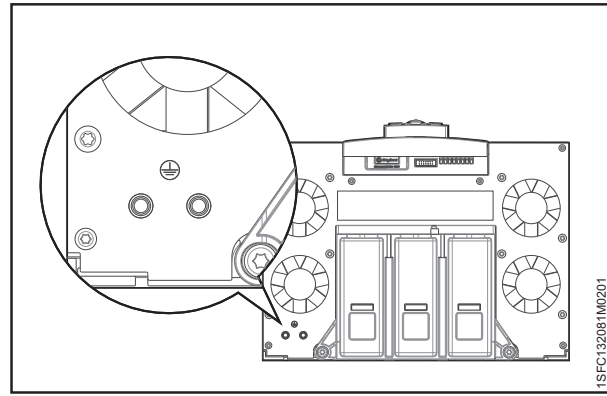
### 5.1.1.2 Softstarter connections



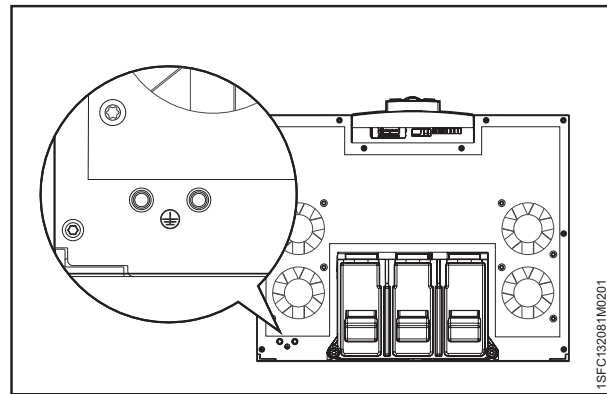
### 5.1.1.3 Protective Earth

Protective Earth is available on PSTX Softstarters with metallic casing with a current of 470 A or more. It is located according to **Figure 5.4**, **Figure 5.5**, and **Figure 5.6** close to the fans. Intended to be used according to regulations.

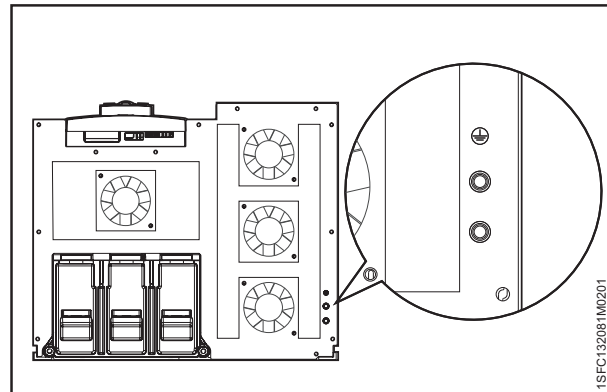
This is only connected to the metallic casing and has no electrical or capacitive connections to anything inside.



**Figure 5.4**  
Protective earth on Frame D (470-570A)



**Figure 5.5**  
Protective earth on Frame E (720-840A)



**Figure 5.6**  
Protective earth on Frame F (1050-1250A)

## 5.1.2 Control supply and control circuit

Wires in industrial control applications are divided into 3 groups: main power supply, control supply and control circuit.

Main power supply (1L1, 3L2, 5L3, 2T1, 4T2, 6T3)

Control supply voltage (terminals 1 and 2)

Control circuit (terminals 13 - 21).

### 5.1.2.1 Control supply voltage - terminals 1 and 2

Connect neutral and phase to terminal 1 and 2.

See **Figure 5.7**.



#### INFORMATION

Make sure that you have the correct supply voltage  $U_s$ . See chapter 3.2.1 General.

The control supply voltage for all PSTX Softstarters is  $U_s$  100-250V AC, 50/60Hz.

If using the operational voltage (Phase /N) as source for control voltage make sure to not exceed  $U_s$  250V -AC, 50/60Hz

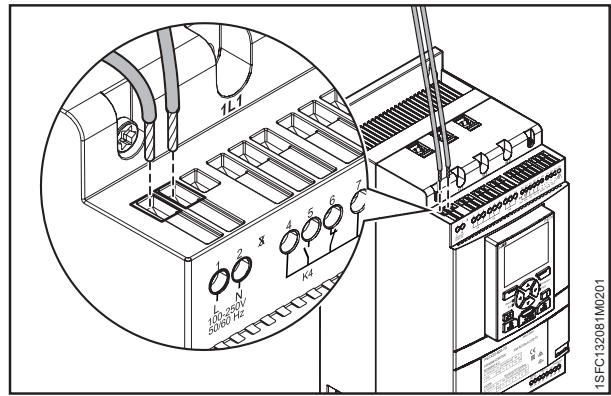


Figure 5.7

Supply voltage and control circuit

Tightening torques and cable dimensions.

	<p>M3,5</p> <p>0,5 Nm 4,3 lb.in</p>	<p>3,5 x 0,6 mm (0.138 x 0.024 in)</p>	<p>AWG 12 ... 24</p> <p>0,2 .. 2,5 mm<sup>2</sup> 2x0,2 .. 1,5 mm<sup>2</sup></p> <p>0,2 .. 2,5 mm<sup>2</sup> 2x0,2 .. 1,5 mm<sup>2</sup></p>
--	---	--	--

### 5.1.2.2 Functional ground - terminal 22

Ground the Softstarters with the terminals as shown in **Figure 5.8** (one connection is sufficient). Connect the cable to a ground point close to the Softstarter. A suitable ground point is next to the Softstarter on the installation plate. Ground the installation plate.



#### INFORMATION

This is not a protective ground, it is a function ground. The grounding cable must be as short as possible. Maximum length 0,5m.



#### INFORMATION

Do not use functional ground in IT-networks, commonly found in for instance marine applications.

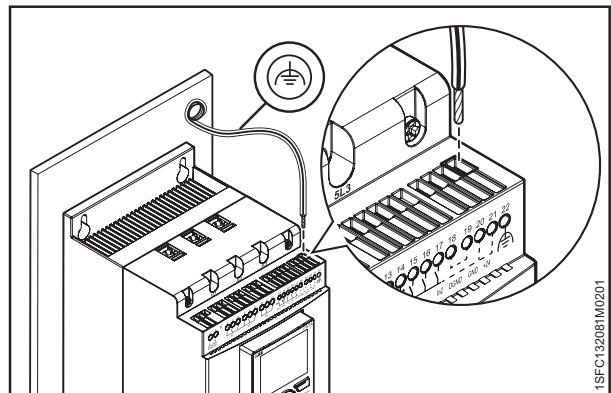


Figure 5.8

Functional ground, terminal 22

Tightening torques and cable dimensions.

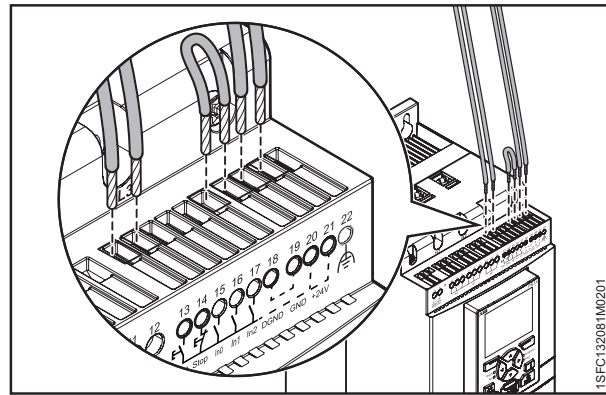
	<p>M3</p> <p>0,5 Nm 4,3 lb.in</p>	<p>3,5 x 0,6 mm (0.138 x 0.024 in)</p>	<p>AWG 12 ... 24</p> <p>0,2 .. 2,5 mm<sup>2</sup> 2x0,2 .. 1,5 mm<sup>2</sup></p> <p>0,2 .. 2,5 mm<sup>2</sup> 2x0,2 .. 1,5 mm<sup>2</sup></p>
--	---------------------------------------	--	--

### 5.1.2.3 Start and Stop - terminals 13, 14, 18, 19, 20, 21

#### Internal control voltage

The PSTX Softstarter has a built-in holding circuit and does not require sustained signals on start input. Use internal control supply voltage from terminals 20 or 21.

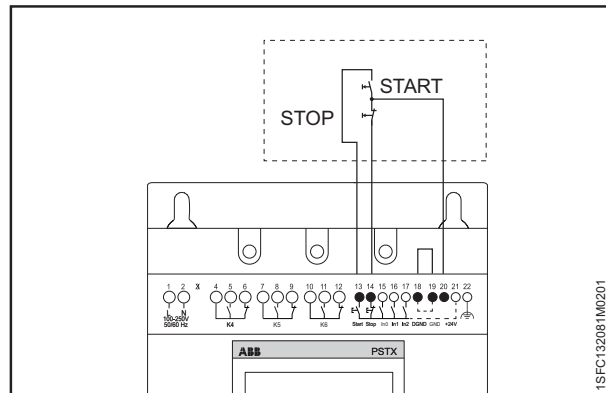
Connect start and stop terminals using conventional circuit with push buttons. See **Figure 5.9** and **Figure 5.10**.



**Figure 5.9**  
Start and Stop, terminals 13, 14, 18, 19, 20, 21

Tightening torques and cable dimensions.

	<p>M3 0,5 Nm 4,3 lb.in</p>	<p>3,5 x 0,6 mm (0.138 x 0.024 in)</p>	<p>AWG 12 ... 24 0,2 .. 2,5 mm<sup>2</sup> 2x0,2 .. 1,5 mm<sup>2</sup> 0,2 .. 2,5 mm<sup>2</sup> 2x0,2 .. 1,5 mm<sup>2</sup></p>
--	------------------------------------	--	--

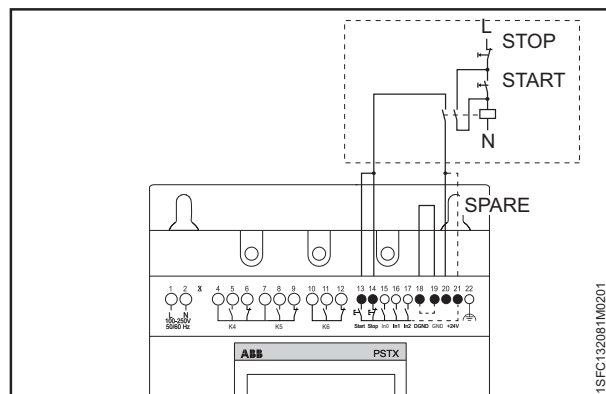


**Figure 5.10**  
Holding circuit (pulse for start is enough)

Tightening torques and cable dimensions.

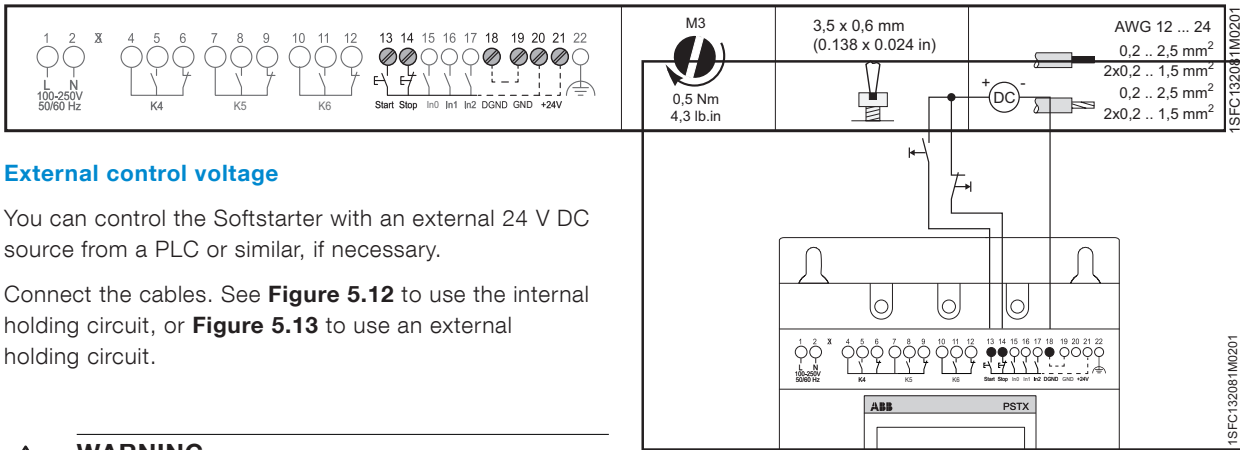
	<p>M3 0,5 Nm 4,3 lb.in</p>	<p>3,5 x 0,6 mm (0.138 x 0.024 in)</p>	<p>AWG 12 ... 24 0,2 .. 2,5 mm<sup>2</sup> 2x0,2 .. 1,5 mm<sup>2</sup> 0,2 .. 2,5 mm<sup>2</sup> 2x0,2 .. 1,5 mm<sup>2</sup></p>
--	------------------------------------	--	--

A conventional circuit with auxiliary relay is also possible. See **Figure 5.11**.



**Figure 5.11**  
Conventional circuit (maintained start signal required)

Tightening torques and cable dimensions.



### External control voltage

You can control the Softstarter with an external 24 V DC source from a PLC or similar, if necessary.

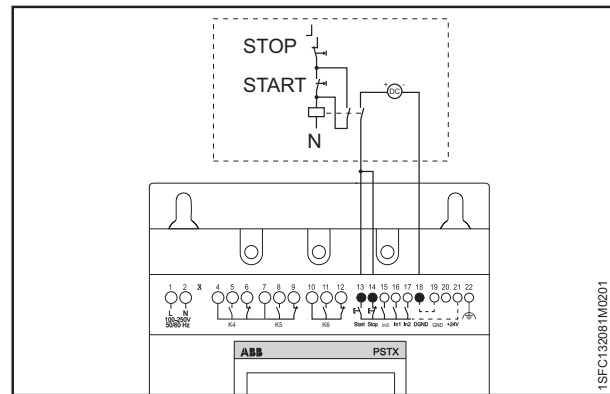
Connect the cables. See **Figure 5.12** to use the internal holding circuit, or **Figure 5.13** to use an external holding circuit.



### WARNING

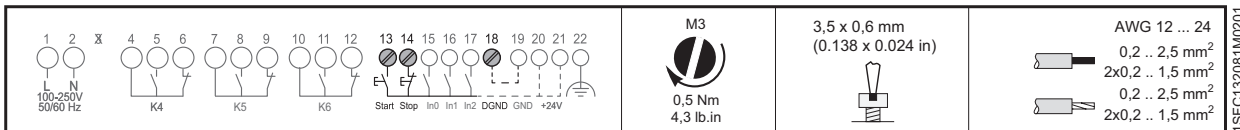
Use only 24 V DC to connect terminal 13, 14, 15, 16 and 17. Other voltages can damage the Softstarter and the warranty will no longer be valid.

**Figure 5.12**  
Holding circuit with external control voltage  
(pulse for start is enough)



**Figure 5.13**  
Conventional circuit with external control voltage  
(maintained start signal is required)

Tightening torques and cable dimensions.



### 5.1.2.4 Programmable inputs - terminals 15, 16 and 17



#### WARNING

Use only 24 V DC to connect terminal 13, 14, 15, 16 and 17. Other voltages can damage the Softstarter and the warranty will no longer be valid.

The Softstarter has 3 programmable inputs.

- In0, default reset event.
- In1, default none
- In2, default none

For programming the Softstarter inputs, see chapter 7.14 **Inputs/outputs**.

Connect the cables, see **Figure 5.14**, and **Figure 5.15** to use the internal control supply voltage, or **Figure 5.14** and **Figure 5.16** to use an external source.

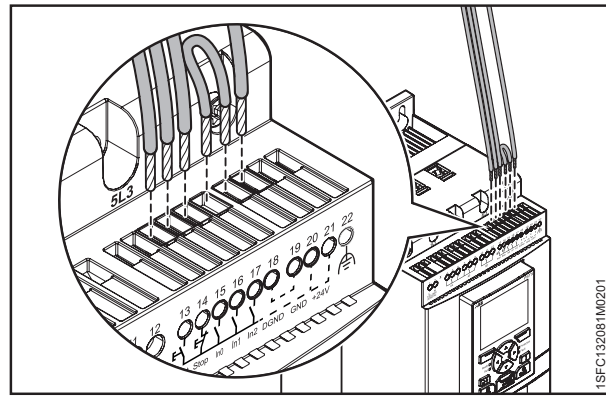


Figure 5.14  
Terminals 16 and 17

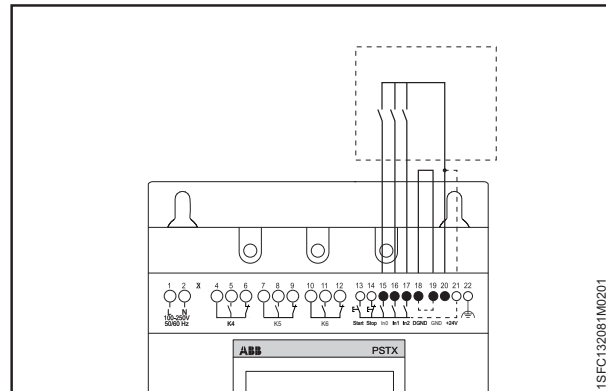


Figure 5.15  
Programmable inputs, terminals 15, 16 and 17



#### INFORMATION

Connections for sequence start, see chapter 5.1.2.5 **Programmable inputs (Sequence start)**

Tightening torques and cable dimensions.

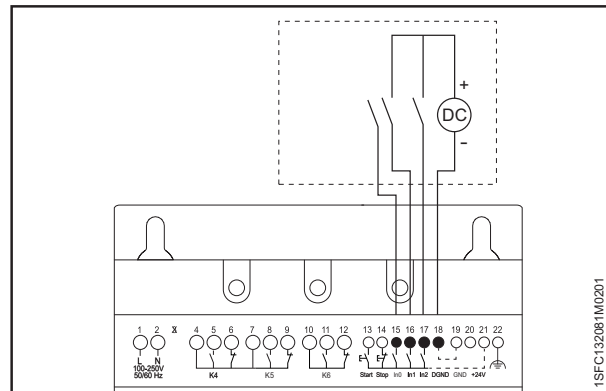
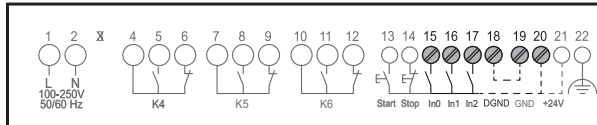
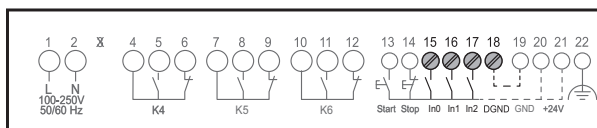


Figure 5.16  
External control voltage

Tightening torques and cable dimensions.



### 5.1.2.5 Programmable inputs (Sequence start)

The Softstarter can start up to 3 different motors used in different applications with different parameter sets. The parameter set is chosen through input signals to the Softstarter.

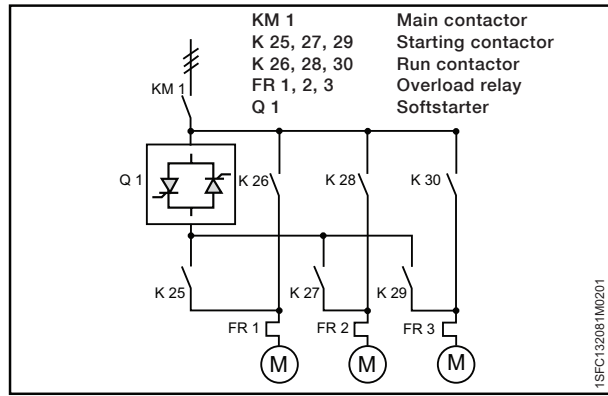
See **Figure 5.17**, Sequential start of motors using a Softstarter.

If the Softstarter trips for any reason, and the trip must stop the motor, all motors are stopped.

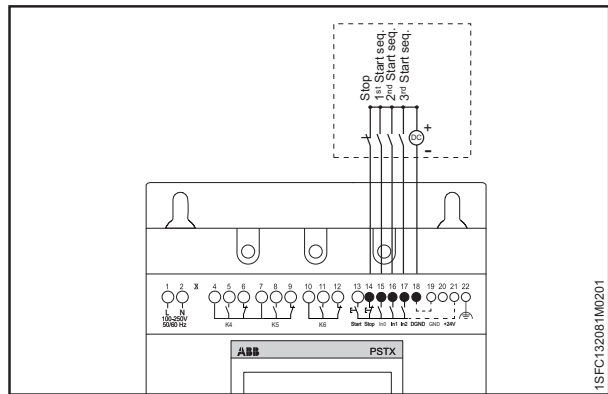
When you use sequence start, see **Figure 5.18** or **Figure 5.19** for the connection.

The start command (terminal 13, 14, 16 and 17) must be maintained during operation, otherwise a direct stop is done.

Soft stop can only be done for the motor currently fed by the Softstarter, by giving a stop command (terminal 14).

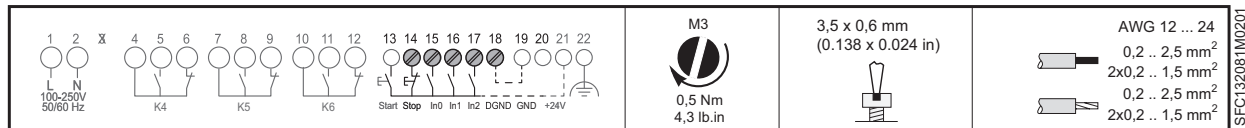


**Figure 5.17**  
Sequential start of motors using a Softstarter



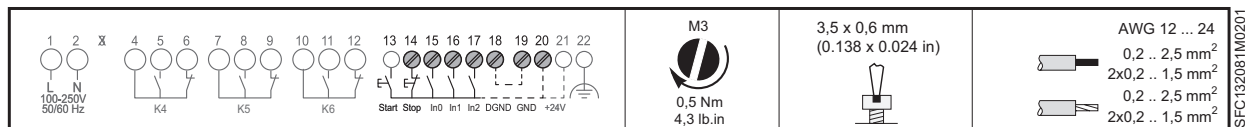
**Figure 5.18**  
External control voltage

Tightening torques and cable dimensions.



**Figure 5.19**  
Internal control voltage

Tightening torques and cable dimensions.



### 5.1.2.6 Programmable output relay - K4, terminals 4, 5 and 6

See chapter **7.14 Inputs/outputs** to set the function of the output relay.

Default: Run

Connect the cables to terminal 4, 5 and 6.

See **Figure 5.20**.

Recommended to control line contactor.

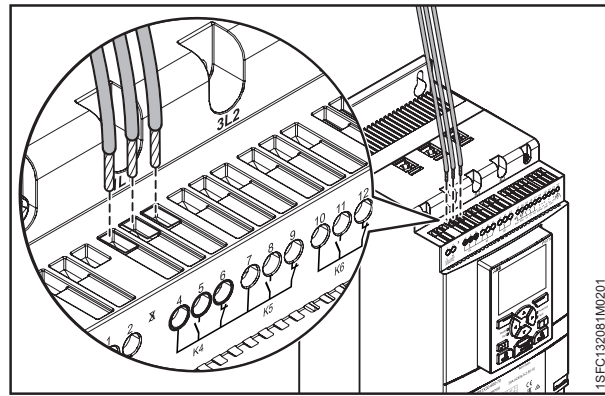


Figure 5.20

Programmable output relay K4, terminals 4, 5 and 6

	<p>M3,5 0,5 Nm 4,3 lb.in</p>	<p>3,5 x 0,6 mm (0.138 x 0.024 in)</p>	<p>AWG 12 ... 24</p> <ul style="list-style-type: none"> <li>0,2 .. 2,5 mm<sup>2</sup></li> <li>2x0,2 .. 1,5 mm<sup>2</sup></li> <li>0,2 .. 2,5 mm<sup>2</sup></li> <li>2x0,2 .. 1,5 mm<sup>2</sup></li> </ul>
--	--------------------------------------	--	---

5

### 5.1.2.7 Programmable output relay - K5, terminals 7, 8 and 9

See chapter **7.14 Inputs/outputs** to set the function of the output relay.

Default: Top of ramp

Connect the cables to terminal 7, 8 and 9.

See **Figure 5.21**.

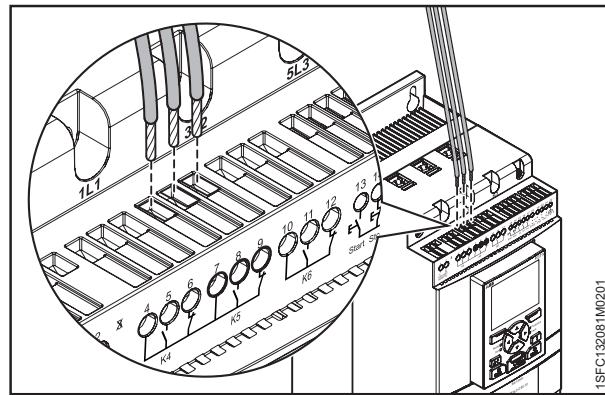


Figure 5.21

Programmable output relay K5, terminals 7, 8 and 9

	<p>M3,5 0,5 Nm 4,3 lb.in</p>	<p>3,5 x 0,6 mm (0.138 x 0.024 in)</p>	<p>AWG 12 ... 24</p> <ul style="list-style-type: none"> <li>0,2 .. 2,5 mm<sup>2</sup></li> <li>2x0,2 .. 1,5 mm<sup>2</sup></li> <li>0,2 .. 2,5 mm<sup>2</sup></li> <li>2x0,2 .. 1,5 mm<sup>2</sup></li> </ul>
--	--------------------------------------	--	---

### 5.1.2.8 Programmable output relay - K6, terminals 10, 11 and 12

See chapter **7.14 Inputs/outputs** to set the function of the output relay.

Default: Event

Connect the cables to terminal 10, 11 and 12.

See **Figure 5.22**.

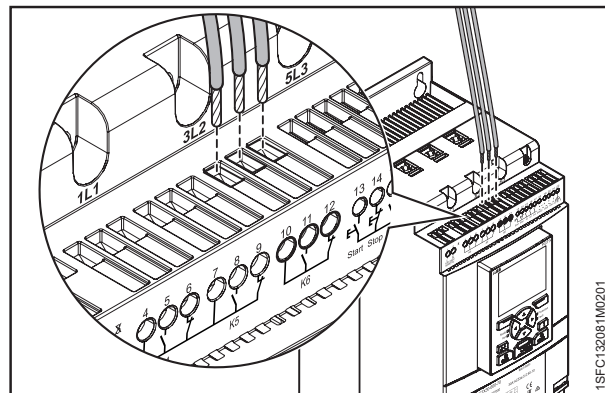


Figure 5.22

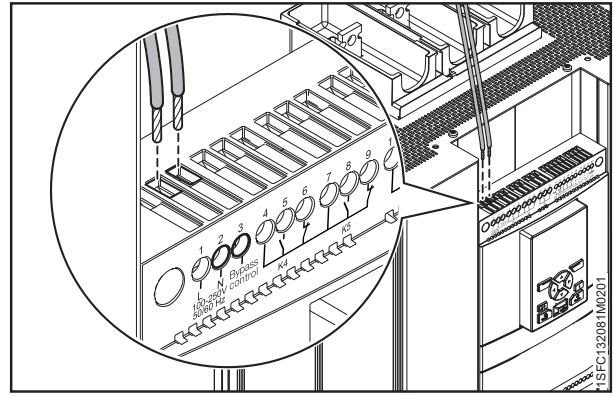
Programmable output relay K6, terminals 10, 11 and 12

	<p>M3 0,5 Nm 4,3 lb.in</p>	<p>3,5 x 0,6 mm (0.138 x 0.024 in)</p>	<p>AWG 12 ... 24</p> <ul style="list-style-type: none"> <li>0,2 .. 2,5 mm<sup>2</sup></li> <li>2x0,2 .. 1,5 mm<sup>2</sup></li> <li>0,2 .. 2,5 mm<sup>2</sup></li> <li>2x0,2 .. 1,5 mm<sup>2</sup></li> </ul>
--	------------------------------------	--	---



### 5.1.2.9 Close bypass PSTX470...PSTX1250

The built-in bypass contactor in PSTX470..1250 can be controlled externally for an direct on line (across the line) start. The built-in bypass contactor is closed by applying voltage (100VAC/DC – 250VAC/DC) between terminal 2 and 3. See **Figure 5.23**. A direct line on line start should only be done up to the AC-3 rating of the internal bypass contactor.



**Figure 5.23**  
Close bypass PSTX470...PSTX1250

### PSTX Integrated bypass ratings

	PSTX Integrated bypass ratings					
	PSTX470	PSTX570	PSTX720	PSTX840	PSTX1050	PSTX1250
<b>Softstarter</b>						
Integrated contactor	AF370			AF750		AF1250
AC-3 rating at 400 V (A)	370			750		-
AC-3 rated operational power at 400 V (kW)	200			400		-
UL/CSA 3-phase motor rating at 480 V (hp)	300			600		-

Tightening torques and cable dimensions.

	<p>0,5 Nm 4,3 lb.in</p>	<p>3,5 x 0,6 mm (0.138 x 0.024 in)</p>	<p>AWG 12 ... 24</p> <p>0,2 .. 2,5 mm<sup>2</sup> 2x0,2 .. 1,5 mm<sup>2</sup> 0,2 .. 2,5 mm<sup>2</sup> 2x0,2 .. 1,5 mm<sup>2</sup></p>
--	-----------------------------	--	---

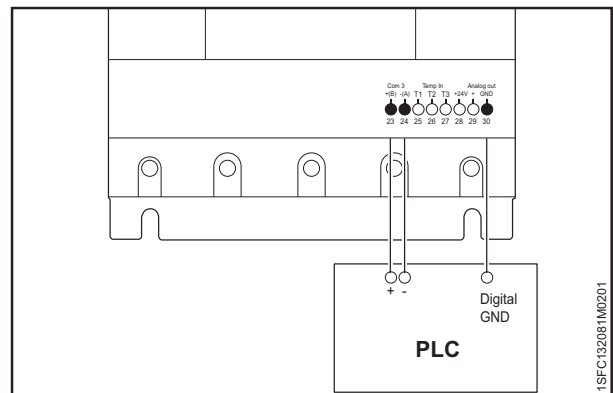
### 5.1.2.10 Modbus RTU

Connect digital ground from PLC to the PSTX ground, terminal 19, 22 or 30.

Terminal 23 to 29 is non-isolated to GND. Terminal 30 is the same as terminal 19 and terminal 22. If voltage is applied to any terminal 23-29 it may break depending on the amplitude of the voltage.

Terminal 23 and 24 will break down if voltage are higher than  $\pm 5,5V$  (relative ground) and have a current more than 150mA. If using different grounds between master and PSTX make sure that they are totally isolated grounds and that the master has isolated power. The master must not have any offset to the PSTX ground. See **Figure 5.24**.

See chapter **8 Communication** for communication components.



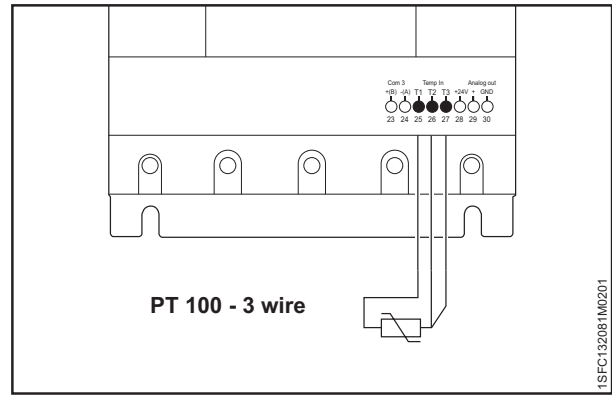
**Figure 5.24**  
Modbus RTU

### 5.1.2.11 Temperature sensor input

If the motor has bi-metal switch, PTC or PT100 elements, connect the cables to terminals 25, 26 and 27. See chapter **7.17.14 Temperature sensors** for programming.

#### 3-wire measurement for PT100

To reduce the influence of the wire resistance, you can use a 3-wire connection. This creates 2 measuring circuits. One circuit is used for reference. This way, the tripping device can calculate the wire resistance. See **Figure 5.25**.



**Figure 5.25**  
PT100 - 3 wire

Tightening torques and cable dimensions.

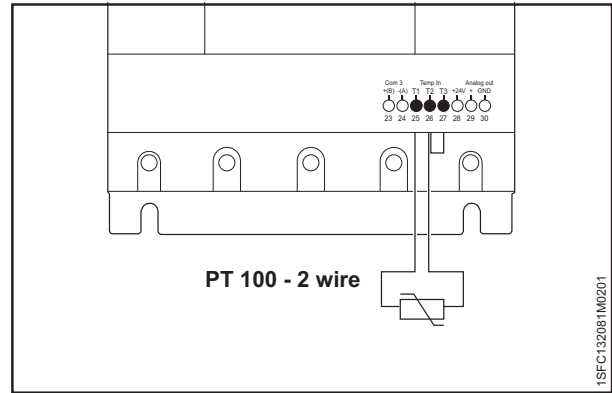
	<p>M3 0,5 Nm 4,3 lb.in</p>	<p>3,5 x 0,6 mm (0.138 x 0.024 in)</p>	<p>AWG 12 ... 24 0,2 .. 2,5 mm<sup>2</sup> 2x0,2 .. 1,5 mm<sup>2</sup> 0,2 .. 2,5 mm<sup>2</sup> 2x0,2 .. 1,5 mm<sup>2</sup></p>
--	------------------------------------	--	--

1SFC132081M0201

5

#### 2-wire measurement for PT100

When using 2-wire temperature sensors, the sensor resistance and the wire resistance are added. Correct for the resulting systematic errors when you change the tripping device. Connect a jumper between the terminals 26 and 27. See **Figure 5.26**. See chapter **7.17.14 Temperature sensors** for programming.



**Figure 5.26**  
PT100 - 2 wire

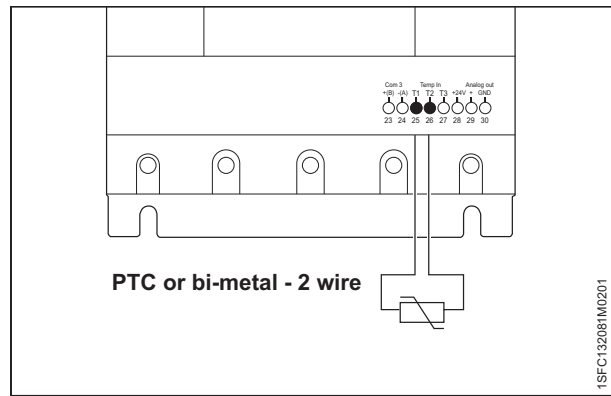
Tightening torques and cable dimensions.

	<p>M3 0,5 Nm 4,3 lb.in</p>	<p>3,5 x 0,6 mm (0.138 x 0.024 in)</p>	<p>AWG 12 ... 24 0,2 .. 2,5 mm<sup>2</sup> 2x0,2 .. 1,5 mm<sup>2</sup> 0,2 .. 2,5 mm<sup>2</sup> 2x0,2 .. 1,5 mm<sup>2</sup></p>
--	------------------------------------	--	--

1SFC132081M0201

### 2-wire measurement for PTC or bi-metal switch

See **Figure 5.27**. See chapter **7.17.14 Temperature sensors** for programming.



**Figure 5.27**

PTC or bi-metal - 2 wire

Tightening torques and cable dimensions.

	<p>M3 0,5 Nm 4,3 lb.in</p>	<p>3,5 x 0,6 mm (0.138 x 0.024 in)</p>	<p>AWG 12 ... 24 0,2 .. 2,5 mm<sup>2</sup> 2x0,2 .. 1,5 mm<sup>2</sup> 0,2 .. 2,5 mm<sup>2</sup> 2x0,2 .. 1,5 mm<sup>2</sup></p>
--	------------------------------------	--	--

### 5.1.2.12 Analog output

The Softstarter has one output for a configurable analog output signal (terminals 29 and 30). The load resistance is maximum 500 ohm for current output, and minimum 500 ohm for voltage output.

The output signal ranges available are 0-10 V, 0 – 20mA or 4-20mA. The default setting is 4-20mA.

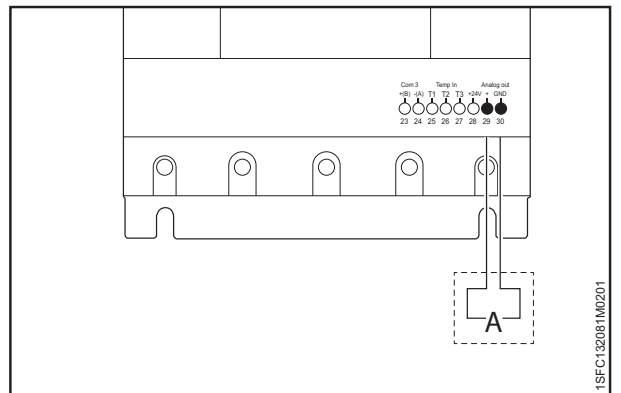
You can select the analog output to show:

I (A), U (V), P (kW), P (Hp), Q (kVAr), S (kVA),

cos Phi, Motor temp, SCR temp and Energy (kWh).

If you use the analog output, connect the cables to terminals 29 and 30. See **Figure 5.28**.

See chapter **7.14 Inputs/outputs** for programming.



**Figure 5.28**

Analog output

Tightening torques and cable dimensions.

	<p>M3 0,5 Nm 4,3 lb.in</p>	<p>3,5 x 0,6 mm (0.138 x 0.024 in)</p>	<p>AWG 12 ... 24 0,2 .. 2,5 mm<sup>2</sup> 2x0,2 .. 1,5 mm<sup>2</sup> 0,2 .. 2,5 mm<sup>2</sup> 2x0,2 .. 1,5 mm<sup>2</sup></p>
--	------------------------------------	--	--

### 5.1.3 Extension I/O

If more inputs and outputs are necessary, you can connect components:

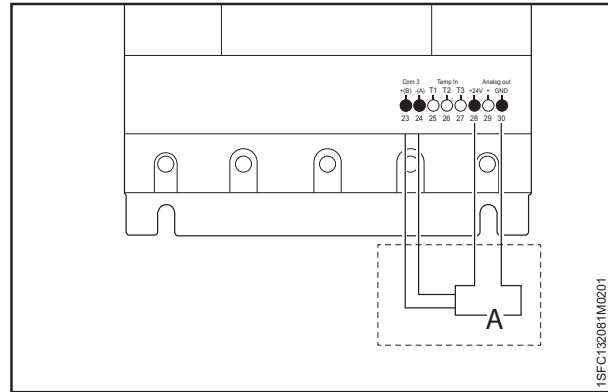
- ABB Stotz DX1xx-FBP extension module

This will give additional:

- 8 digital input
- 4 output relay
- 1 analog output

Connect the cables to terminals 23,24, 28 and 30. See **Figure 5.29**.

See chapter **8 Communication** for communication components.



**Figure 5.29**  
Optional accessories

5

Tightening torques and cable dimensions.

	<p>M3 0,5 Nm 4,3 lb.in</p>	<p>3,5 x 0,6 mm (0.138 x 0.024 in)</p>	<p>AWG 12 ... 24 0,2 .. 2,5 mm<sup>2</sup> 2x0,2 .. 1,5 mm<sup>2</sup> 0,2 .. 2,5 mm<sup>2</sup> 2x0,2 .. 1,5 mm<sup>2</sup></p>
--	------------------------------------	--	--

# 6 Human machine interface (HMI)

## 6.1 Navigation Overview

	52
6.1.1 LED indicators	52
6.1.2 Keypad	53
6.1.2.1 Lock/Unlock keypad	53
6.1.3 Navigation screen	54
6.1.3.1 Edit parameter values	54
6.1.4 Configure HMI	55
6.1.5 Symbols in screen	56
6.1.4.1 Changing the Rated motor current (Setting Ie)	55

## 6.2 Local control from keypad

	57
6.2.1 Start key	57
6.2.2 Stop key	57
6.2.3 R/L-key	57
6.2.4 Motor jog	58

## 6.3 Options screen

	59
6.3.1 Overview	59
6.3.2 Edit home view	43
6.3.2.1 Add information screens to home view	59
6.3.2.2 Edit information screens in home view	59
6.3.2.3 Display slot	59
6.3.2.4 Scale value range	60
6.3.3 Active faults/protections and warnings	60
6.3.4 Configure HMI	61

## 6.4 Menu screen

	62
6.4.1 Parameters	62
6.4.1.1 Complete list	62
6.4.1.2 Favorites	64
6.4.1.3 Modified	64
6.4.2 Assistants	65
6.4.3 Event log	66
6.4.4 Backup	67
6.4.4.1 Create backup	67
6.4.4.2 Uploading of parameters	67
6.4.5 System info	68
6.4.6 Settings	68
6.4.6.1 Language	69
6.4.6.2 Date and time	70
6.4.6.3 Display settings	70
6.4.6.4 Reset to defaults	71

This chapter gives a description of how the Human-machine interface (keypad and screen) works. For detailed description of each function, see chapter 7

## Functions.

### 6.1 Navigation Overview

You can use the Human-machine interface (HMI) to change the settings of the Softstarter, such as inputs and outputs, protections, warnings, and communications. You can also use the HMI to monitor, control and read status information of the Softstarter.

See **Figure 6.1**.

The HMI contains of:

- Screen
- Selection and Navigation keys
- Mini USB port
- LED status indicators

6

#### 6.1.1 LED indicators

The LED status indicators work as in **Table 1 LED status**:

LED	Color	Description
<b>Ready</b> ①	Green	<ul style="list-style-type: none"> <li>• <b>Off:</b> When control supply voltage <math>U_s</math> is off or unconnected.</li> <li>• <b>Flashing light:</b> When control supply voltage <math>U_s</math> is On and operation voltage <math>U_e</math> is Off.</li> <li>• <b>Steady light:</b> When control supply voltage <math>U_s</math> is On, and operation voltage <math>U_e</math> is On.</li> </ul>
<b>Run</b> ②	Green	<ul style="list-style-type: none"> <li>• <b>Off:</b> When the motor does not run.</li> <li>• <b>Flashing light:</b> When Softstarter is controlling operation voltage <math>U_e</math> during start or stop ramp.</li> <li>• <b>Steady light:</b> When full operation voltage <math>U_e</math> is on at Top of Ramp.</li> </ul>
<b>Protection</b> ③	Yellow	<ul style="list-style-type: none"> <li>• <b>Off:</b> When the Softstarter did not trip on protection</li> <li>• <b>Flashing light:</b> The protection tripped and reset is possible.</li> <li>• <b>Steady light:</b> The protection tripped and reset is not possible.</li> </ul>
<b>Fault</b> ④	Red	<ul style="list-style-type: none"> <li>• <b>Off:</b> When the Softstarter did not trip on fault</li> <li>• <b>Flashing light:</b> Fault occurred and reset is possible.</li> <li>• <b>Steady light:</b> Fault occurred and reset is not possible.</li> </ul>

See **Figure 6.2**.

When fault or protection LED is on, the screen shows the fault or protection as an event code and an indication text. Push information-key for further information.

See chapter 10 **Troubleshooting** for description of fault, protections and warnings.

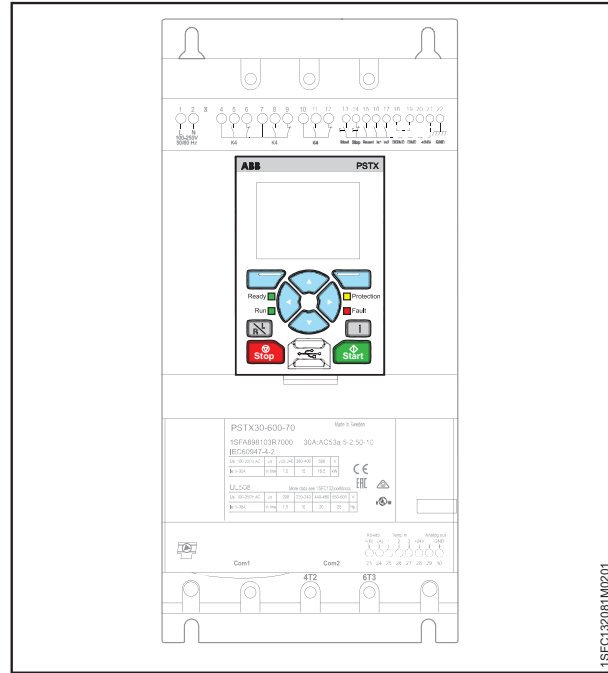


Figure 6.1

HMI

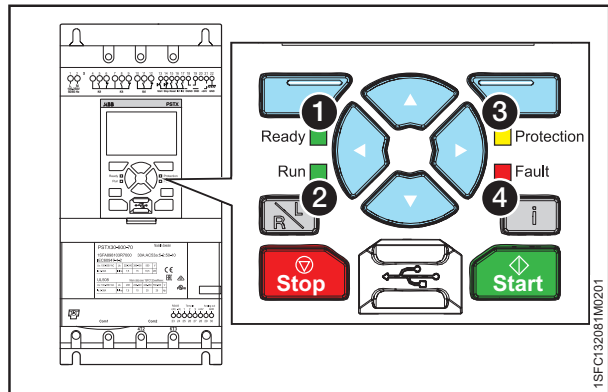


Figure 6.2

LED Status

## 6.1.2 Keypad

The Softstarter has 10 keys on the keypad, see **Figure 6.3**. This chapter gives a description of the function of each key.

### Selection soft keys

The Selection soft keys have a specified function for each dialogue, such as to select, to exit, to change or to store. The screen above the key shows the current function. See **1** in **Figure 6.3**.

### Navigation keys

Use the Navigation keys for navigation in the menu and change the parameter values. A menu/value that is highlighted black on the screen can be changed or scrolled. To select from a list, you can scroll in a closed loop. See **2** in **Figure 6.3**.

### R\L-key

R\L-key stands for Remote or Local. Use this key to change the control of the Softstarter between local control from the HMI and remote control from hardware input or fieldbus. See **3** in **Figure 6.3**.

### i-key

Use the i-key to get information about the HMI, and the Softstarter status and settings. Push this key for help and general information about the current setting in the HMI. See **4** in **Figure 6.3**.

### Stop key

The Stop key is the stop switch for the Softstarter. When you push this key, the motor stops with the set parameters. You can push stop command during the start ramp if necessary. (Only active in local control mode). See **5** in **Figure 6.3**.

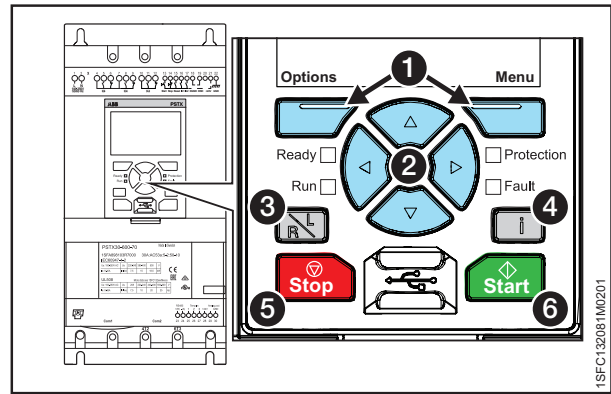
### Start key

When you push this key, the motor starts and operates with the set parameters. (Only active in local control mode). See **6** in **Figure 6.3**.

### 6.1.2.1 Lock/Unlock keypad

Be aware of that the different lock mechanisms provided by PSTX provide no security level whatsoever. The only intention is to prevent the user from making changes by mistake.

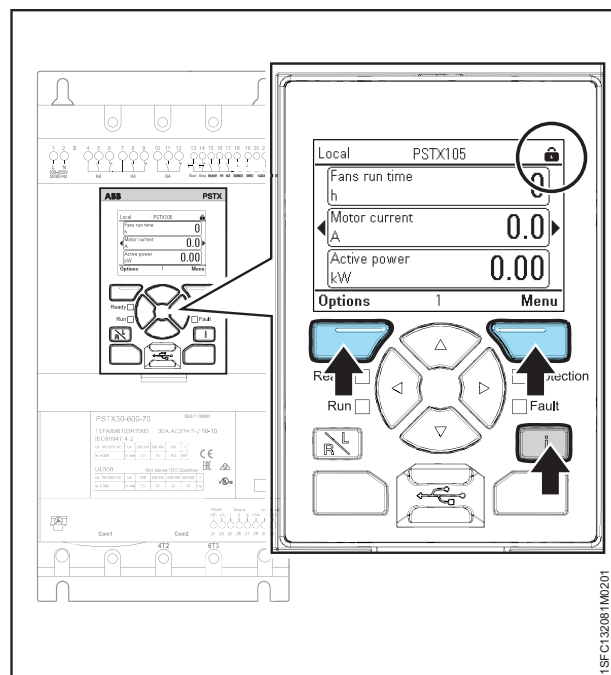
Push and hold the Options-key, Menu-key and i-key Simultaneously for 2 seconds in order to lock/unlock the keypad. **Figure 6.4**. The lock prevents only accidental use of keys. The display will show the home view and the only keys that can be used are the left and right keys in order to step through the home view.



**Figure 6.3**  
Keypad

**Table 2** Keypad, Figure 46





Position	Key
<b>1</b>	Selection soft keys
<b>2</b>	Navigation keys
<b>3</b>	R\L-key
<b>4</b>	i-key
<b>5</b>	Stop key
<b>6</b>	Start key



**Figure 6.4**  
HMI

### 6.1.3 Navigation screen

With the keypad, you can change the settings for each item or as a selection of default parameters for different applications. The default set of parameters is stored in the unit for a possible reset to default values. When the fieldbus communication is selected, you can change parameters from this interface.

Push  "Menu" to go to the menu and then use  and  to navigate. Push the  "Select" to make your selection.

See **Figure 6.5**.








Figure 6.5

Navigation screen

#### 6.1.3.1 Edit parameter values

##### The numerical setting

Use the numerical setting to change a numerical value. Use  and  on the Navigation keys to select the number, the selected number is highlighted black. Then Push  or  to change the value of the selected number. Push  "Save" to save.

See **Figure 6.6**.

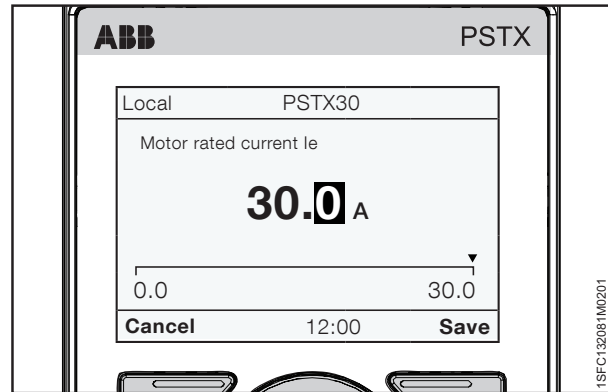






Figure 6.6

Numerical setting

##### On/off switch

Use  or  to navigate  or  to change the value of the selected switch, (1=on, 0=off).

Push  "Save" to save.

See **Figure 6.7**.

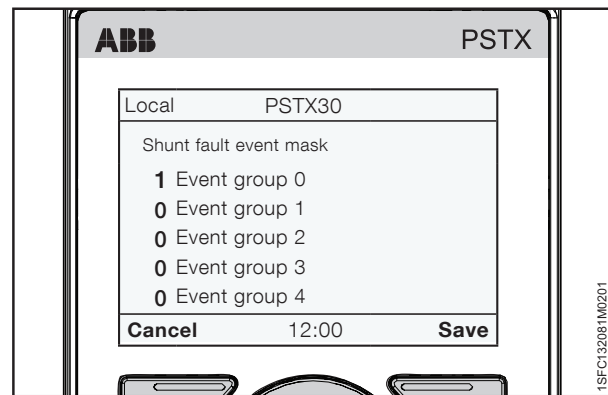



Figure 6.7

Switch setting

##### Selection list

Use the Navigation keys to navigate up and down in the lists. The selected option is highlighted black. Push  "Save" to save.

See **Figure 6.8**.

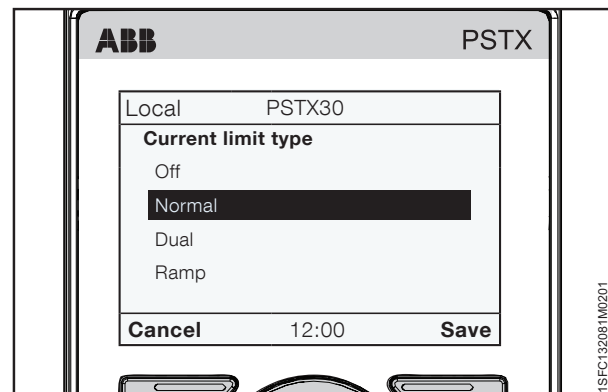


Figure 6.8

Selection list



## 6.1.4 Configure HMI

This chapter shows some examples of parameters that you can set on the PSTX Softstarter.












Some of the service parameters in 28 Service are protected by a service code, see chapter **6.3.4 Configure HMI**.

### 6.1.4.1 Changing the Rated motor current (Setting $I_e$ )

Path in menu:

Menu ► Parameters ► Complete list ► 01 Motor rated current  $I_e$

For more information about Motor Current  $I_e$ , see chapter **7 Functions**.

1. The Home view is the top level. Push  "Menu" to enter the menu. The screen now appears as in **Figure 6.9**.
2. Push  "Select" to select Parameters menu.
3. Push  "Select" to select Complete list.
4. Push  "Select" to select 01 Motor rated current  $I_e$ .
5. Push  "Edit" to edit the rated current in Motor rated current  $I_e$ .
6. Use  and  to select number, the current selected number is highlighted black. Then push  or  to change the value of the selected number. Save the new setting by selecting  "Save".  
See **Figure 6.9**. If you want to quit, you select  "Cancel".

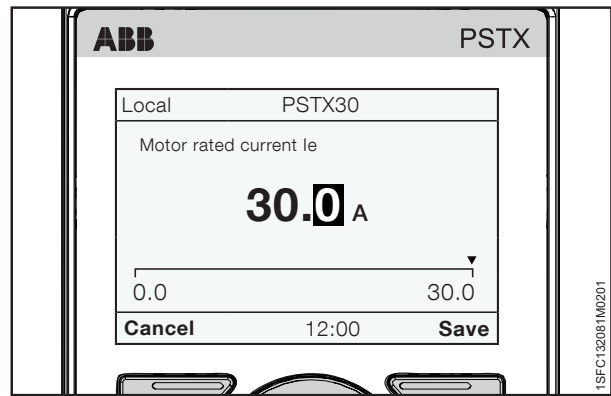


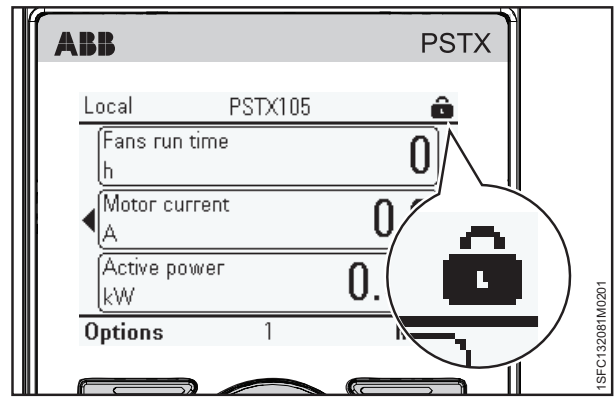
Figure 6.9

Motor current  $I_e$

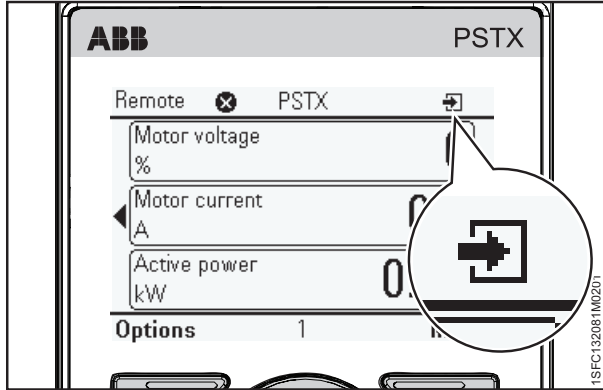
## 6.1.5 Symbols in screen

This chapter describes the different symbols that can appear in the upper right corner of the HMI screen.

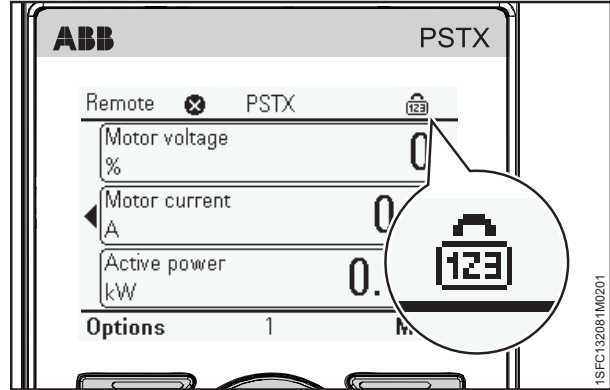
1. Lock / Unlock keypad, See **Figure 6.10**
2. Service profile. See **Figure 6.11**
3. Lock parameter by a lock code, See **Figure 6.12**
4. Lock keys by a lock code, See **Figure 6.13**
5. Emergency mode, See **Figure 6.14**
6. Fault(s) set to off, See **Figure 6.15**



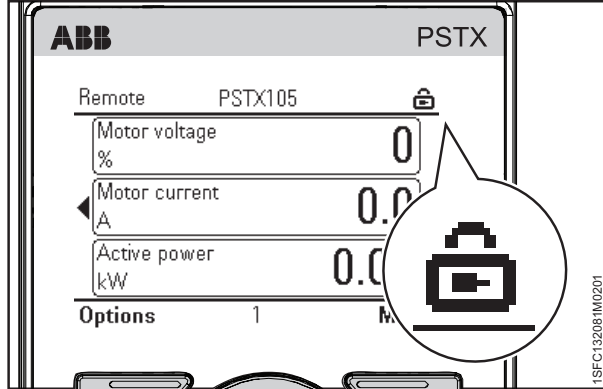
**Figure 6.10**  
Lock / Unlock keypad



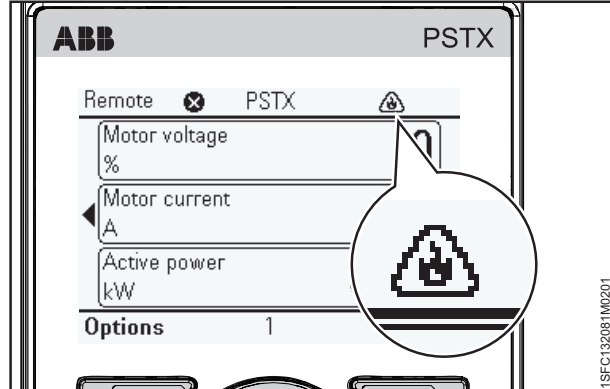
**Figure 6.11**  
Service profile



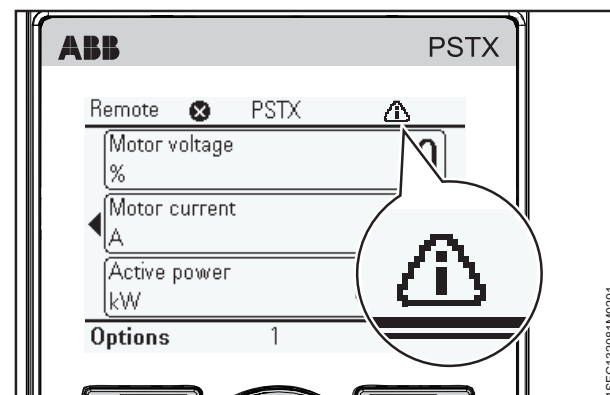
**Figure 6.12**  
Lock parameter by a lock code



**Figure 6.13**  
Lock keys by a lock code



**Figure 6.14**  
Emergency mode



**Figure 6.15**  
Fault(s) set to off

## 6.2 Local control from keypad



### WARNING

When you change from local control to remote control, the setting applies immediately. If the remote setting has direct motor start it can start the motor automatically and can cause personal injury.



### WARNING

After a power loss, software upgrade or cycling of the PSTX Control supply, the PSTX automatically is set in remote control. Remote control is the default control of the PSTX.



### INFORMATION

Keypad control has the highest priority and overrides all other control methods

This chapter gives a description of how the local control interface works. Use the local control to start and stop the motor from the keypad. When local control is selected, you can only control the Softstarter with the keypad.

**Table 3** Local control from keypad

Function	Description
Start/stop	Start and stop the motor with the keypad.
R\L	Change between local and remote control
Motor Jog *	Run the motor as long as Jog is pushed.

\*) For information about Motor jog see **chapter 6.2.4 Motor jog**.

To go to the Motor Jog, follow this path in menu:

Menu ► Motor jog

### 6.2.1 Start key

The start key is the start switch for the Softstarter. Push this key to start the motor and operate with the set parameters. See **1** in **Figure 6.16**.

### 6.2.2 Stop key

The stop key is the stop switch for the Softstarter. Push this key to stop the motor with the set parameters. You can push stop command during the start ramp if necessary. See **2** in **Figure 6.16**.

### 6.2.3 R\L-key

R\L-key stands for Remote or local control. Use this key to control the Softstarter remote from digital input, fieldbus or local from the HMI. See **3** in **Figure 6.16**.



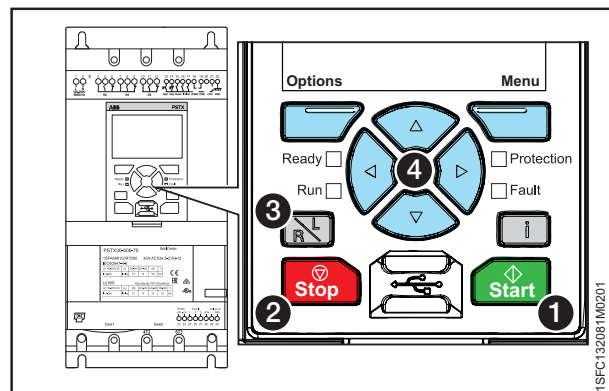
### WARNING

When changing from remote control to local control, the softstarter stays in present state. That means, if the the softstarter is running the motor when switching between the remote control and local control, the softstarter will continue to run the motor.



### WARNING

Since the keypad has highest priority, when in local control, neither the digital inputs nor the fieldbus communication can stop the motor if it is running. When in local control the only stop command that can stop the motor is the stop key on the keypad.



**Figure 6.16**  
Local control

## 6.2.4 Motor jog

Path in menu:

Menu ► Motor jog

For navigation see **Figure 6.17**.

For Motor jog parameter settings, see chapter 7.9 **Slow speed**.




Jog is a slow speed drive function to drive the motor with low voltage output. Use this feature for example to put a conveyor belt into position.



The jog has 3 default speeds:

- Fast Jog
- Jog
- Creep

You can change the speeds with separate parameters. For example: Fast jog backward and jog forward. You can use this function through the HMI, I/O or Fieldbus.

6

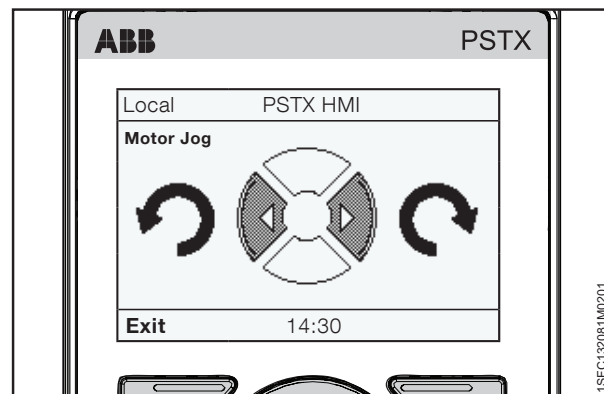
Push  "Menu" to enter the Motor jog menu and then select Motor Jog. Use  and  to jog forward or backwards. See **Figure 6.18**. The motor starts and accelerates to the rated speed with the set parameters as long as the Jog command is in operation.

The motor stops immediately when you release the push button,  and .

You can run the motor in the forward and reverse direction with 3 different speeds.



**Figure 6.17**  
Motor jog navigation



**Figure 6.18**  
Keypad

## 6.3 Options screen

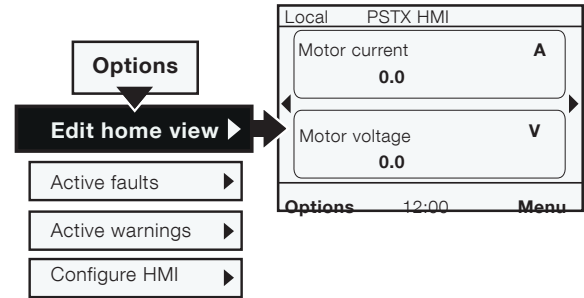
### 6.3.1 Overview

In Options screen, you can change the appearance of the Home view of the Softstarter and read Active faults/ protections and Active warnings.

Option screen includes these menus:

- Edit home view
- Active faults/ protections
- Active warnings

Push  "Options" to enter the Options screen.



**Figure 6.19**  
Edit home view navigation

### 6.3.2 Edit home view



Path in menu:

Options ► Edit home view



For navigation, see **Figure 6.19**.

Use Edit home view to change the view of the home view.

#### 6.3.2.1 Add information screens to home view

1. Push  "Options" to select Edit home view.
2. Use the Navigation keys to select where you want to add an information screen.
3. Push  "Add" to add the new information screen to the home view.



#### 6.3.2.2 Edit information screens in home view

1. Push  "Options" and then select Edit home view.
2. Use the Navigation keys to select the display slot you want to edit.
3. Push  "Edit" and enter the Display slot menu. See chapter **6.3.2.3 Display slot** to set the new screen in the Display slot menu.

#### 6.3.2.3 Display slot

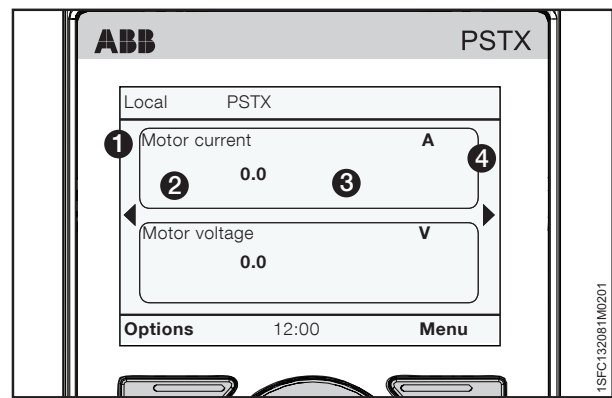
In the Display slot menu, you can set the new screen with these options:

##### Signal

Push  "Edit" to see the list of signals available for the home view. Use the Navigation keys and then push  "Select" to select the signal. Selected signal is shown by **1** in **Figure 6.20**.

Select 1 of these signals:

- Empty
- Motor voltage
- Motor current
- Active power
- Active power (hp)
- Power factor
- Reactive power
- Apparent power
- Mains voltage
- Mains frequency
- Motor connection
- Phase sequence



**Figure 6.20**  
Display slot


- Phase L1 current
- Phase L2 current
- Phase L3 current
- L1L2 phase-to-phase voltage
- L2L3 phase-to-phase voltage
- L3L1 phase-to-phase voltage
- Thyristor temperature
- Motor temperature
- EOL time to trip
- EOL time to cool
- Active energy
- Active energy (resettable)
- Reactive energy
- Reactive energy (resettable)
- Voltage imbalance
- Mains voltage THD
- PT100 temperature
- PTC resistance
- Remaining time to start
- Number of starts (resettable)
- Number of starts
- Motor run time (resettable)
- Motor run time
- Thyristor run time (resettable)
- Thyristor run time
- Fans run time
- Pre-start function
- Start mode
- Stop mode

### Display style

Select the display style for the home view. The selected display style is shown by ② in **Figure 6.21**.

Select numeric, gauge or graph data:

- Numeric
- Gauge/bar
- Graph 15 minutes
- Graph 30 minutes
- Graph 1 hour
- Graph 24 hours
- N/A

Use the Navigation keys to select display style, push  "Select" to set the parameter.

### Display decimals

Select the amount of decimal numbers in the home view. Use the Navigation keys to change the amount.

Push "Save" to save the value. Decimal numbers are shown in ③ in **Figure 6.21**.

### Display name


You can change the name of the selected signal. The new name can have maximum 20 characters.

Use the Navigation keys to change the characters.

Push  "Save" to save the display name. Display name is shown by ① in **Figure 6.21**.


### Signal min

Select the minimum value that can be shown in the gauge/bar or graph in the Home view. Use the Navigation keys to change the value.


Push  "Save" to save the value. Value is shown by ③ in **Figure 6.21**.

### Signal max



Select the maximum value that can be shown in the gauge/bar or graph in the Home view. Use the Navigation keys to change the value.



Push  "Save" to save the value. Value is shown by ③ in **Figure 6.21**.


#### 6.3.2.4 Scale value range

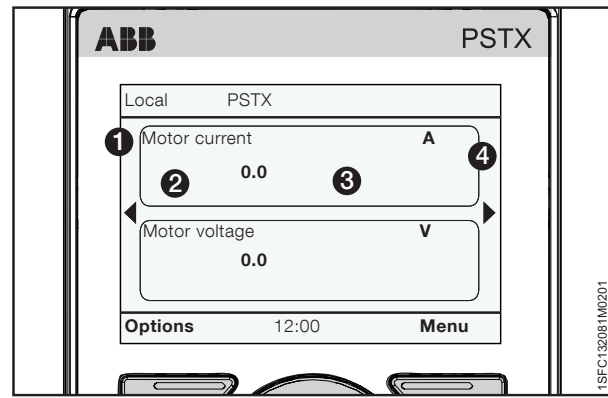
Use Navigation keys to mark Scale value range and push  "Select" to enable Scale value range. 3 more options show in the display slot menu:

- Display signal min as
- Display signal max as
- Display unit

**Display signal min as** - Push  "Edit" to select the scaled minimum value in the Home view. Use the Navigation keys to change the value, Push  "Save" to save the value. See ③ in **Figure 6.21**.

**Display signal max as** - Push  "Edit" to select the scaled maximum value to show in the Home view. Use the Navigation keys to change the value, Push  "Save" to save the value. See ③ in **Figure 6.21**.

**Display unit** - Type in the unit to show in the Home view. You can type a unit with up to 10 characters. Use the Navigation keys to change the characters. Push  "Save"



**Figure 6.21**  
Display slot

to save the Home view unit name. See ④ in **Figure 6.21**.

### 6.3.3 Active faults/protections and warnings

Path in menu:

Options ▶ Active faults / protections

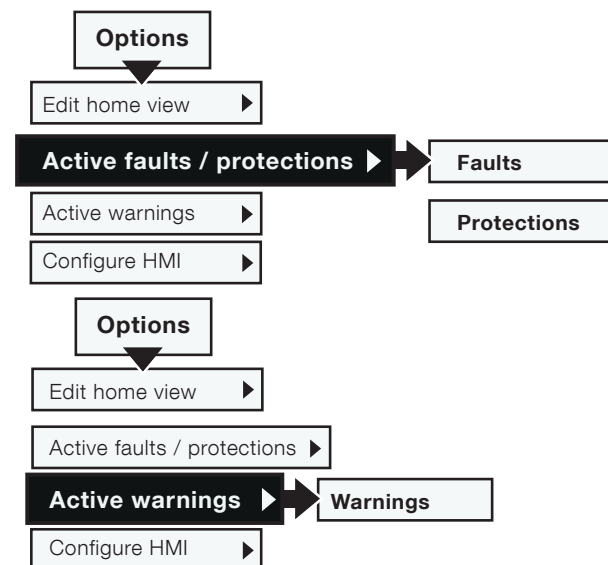
Options ▶ Active warnings

You can find **active faults/protections/warnings** in the Options menu. The menus contain information about faults and warnings that occurred during operation, and what protections are active.

Active faults/protections and warnings menus are highlighted black when a fault protection or warning occurred.

For navigation see **Figure 6.22**.

For more information about fault/warnings/protections, see chapter **10 Troubleshooting**.



**Figure 6.22**  
Active fault/warnings/protections navigation

## 6.3.4 Configure HMI

Path in menu:

Options ► Configure HMI

Configure HMI let you Lock parameters (write protect parameters) and Lock keys on the HMI. The service profile overrides these configurations.

### Lock/Unlock parameters by a lock code

All parameters can be locked by a lock code to prevent users to change any settings. To unlock the parameters, the user needs to know the lock code.

Select Lock parameters and enter the lock code when prompted. Use arrow keys to enter value. The parameter lock icon will be visible in the upper right corner, see chapter 6.1.5 **Symbols in screen**. The same steps applies for Unlock parameters and the parameter lock icon will disappear. If you have entered the service profile you will not be asked to provide the lock code and the configuration is not activated until you exit the service profile.

Note: when the motor control lock is active, it is not possible to use jog with slow speed or pump cleaning with the HMI.

### Lock/Unlock keys by a lock code

Start key, Stop key and R/L key can be locked by a code to prevent a motor start from HMI by mistake. When Lock keys is enabled and start, stop or R/L key is pressed a message will be displayed, "Motor control lock is enabled". To unlock these keys the user needs to know the lock code.

Select Lock keys and enter the lock code when prompted. Use arrow keys to enter value. The key lock icon will be visible in the upper right corner, see chapter 6.1.5 **Symbols in screen**. Unlock keys requires the lock code to be re-entered and then the key lock icon disappears. If you have entered the service profile you will not be asked to provide the lock code and the configuration is not activated until you exit the service profile.

### Change lock code

The default lock code is 12345 and to change it select Change lock code and enter first the current code and then the new code when prompted. Use arrow keys to enter value. If you have forgotten the lock code you can reset all parameters to default, see chapter 6.4.6.4 **Reset to defaults**

If you have entered the service profile you will not be asked to provide the current lock code.



#### INFORMATION

If you use Reset all parameters, you will not only reset the lock code for Basic or Advanced user profile, but also all the other parameters that have changed value from default.



#### INFORMATION

You will automatically exit the user profile after 1h.



#### WARNING

By changing any of the Service parameters, which are locked by user profile Service, could result in personal injury and damage to equipment or property and the warranty will no longer be valid.

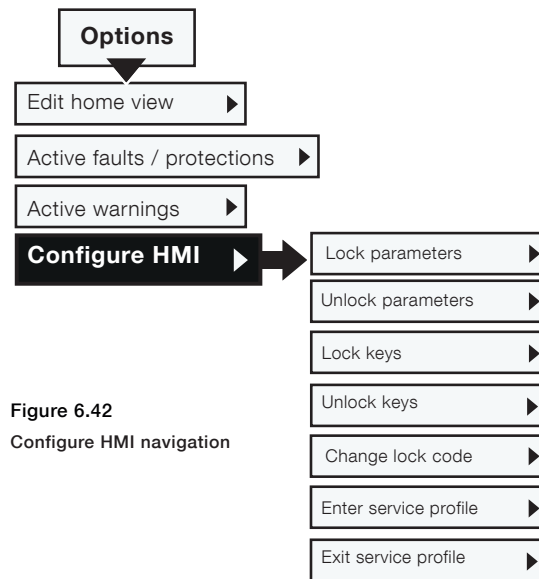


Figure 6.42

Configure HMI navigation

### Enter/Exit service profile

Enter service profile to be able to edit the service parameters that are locked for normal users (see list below). It will also override parameter lock and key lock if any of them are activated.

Service profile code is available in the Service manuals:

- 1SFC13105M0201-Service manual PSTX210...570
- 1SFC132115M0201-Service manual PSTX720...840
- 1SFC132116M0201-Service manual PSTX1050...1250

### Service profile

The below listed parameters can only be changed when logged in as user profile "Service". Please see PSTX service manual for more information.





- 28.14 Mains lock setting
- 28.15 Minimum trig time
- 28.17 U start ramp switch level
- 28.18 T start ramp switch level
- 28.19 Stop ramp switch level
- 28.20 In-Line gain
- 28.21 Inside delta gain
- 28.22 Phase loss
- 28.23 Phase loss during TOR
- 28.24 Phase loss trip time
- 28.25 Phase loss trip angle 1
- 28.26 Phase loss trip angle 2
- 28.27 Bad network quality
- 28.28 Low supply voltage
- 28.29 High current fault
- 28.30 Shunt fault
- 28.31 Short circuit thyristor
- 28.32 Open circuit thyristor
- 28.33 Thyristor overload
- 28.34 Heat sink overtemp
- 28.35 Faulty connection
- 28.36 Faulty usage
- 28.37 Close bypass curr lvl
- 28.49 Shunt fault trip time
- 28.50 Shunt fault trip level
- 28.63 Flux support min speed
- 28.64 Electronics failure

## 6.4 Menu screen

The menu screen has 7 submenus, given in these chapters:

**Table 4** Menu screen

Chapter	Description
6.4.1 Parameters	Parameter settings for different types of Softstarters.
6.4.2 Assistants	Default parameters for common applications.
6.2.4 Motor jog	See chapter 6.2.4 Motor jog
6.4.3 Event Log	Show the Event Log, Faults, Protections and Warnings.
6.4.4 Backup	Backup parameter settings.
6.4.5 System info	Show product name, type, Firmware version etc.
6.4.6 Settings	Softstarter settings such as Language, Date and Display.

Use Navigation keys to navigate in the submenu. Push  "Select" to enter a menu. Push  "Save" to save a new setting. Push  "Cancel" to exit a setting without saving. Push  "Back" to go back.

6

### 6.4.1 Parameters





Path in menu:

Menu ▶ Parameters

The parameter menu has 3 submenus, given in these chapters:

**Table 5** Parameters screen

Chapter	Description
6.4.1.1 Complete list	Shows all parameters for advanced setup
6.4.1.2 Favorites	Select favorite parameter functions for quick selection.
6.4.1.3 Modified	Shows changed parameters.





Navigation keys to navigate in the submenu. Push  "Select" to enter a menu. Push  "Save" to save a new setting. Push  "Cancel" to exit a setting without saving. Push  "Back" to go back.

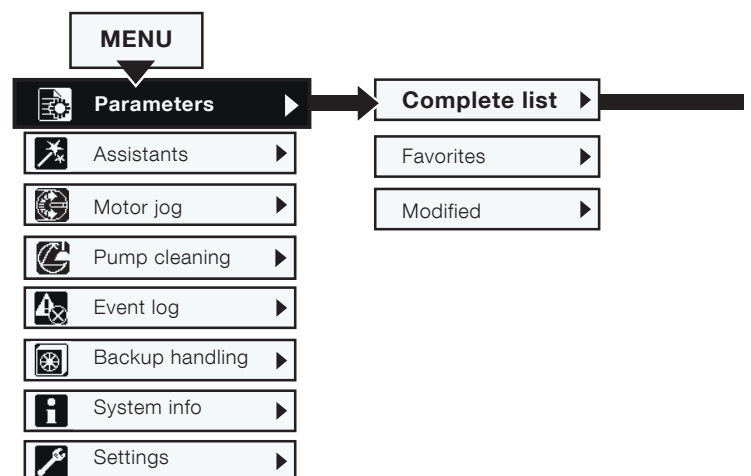
#### 6.4.1.1 Complete list

Path in menu:

Menu ▶ Parameters ▶ Complete list

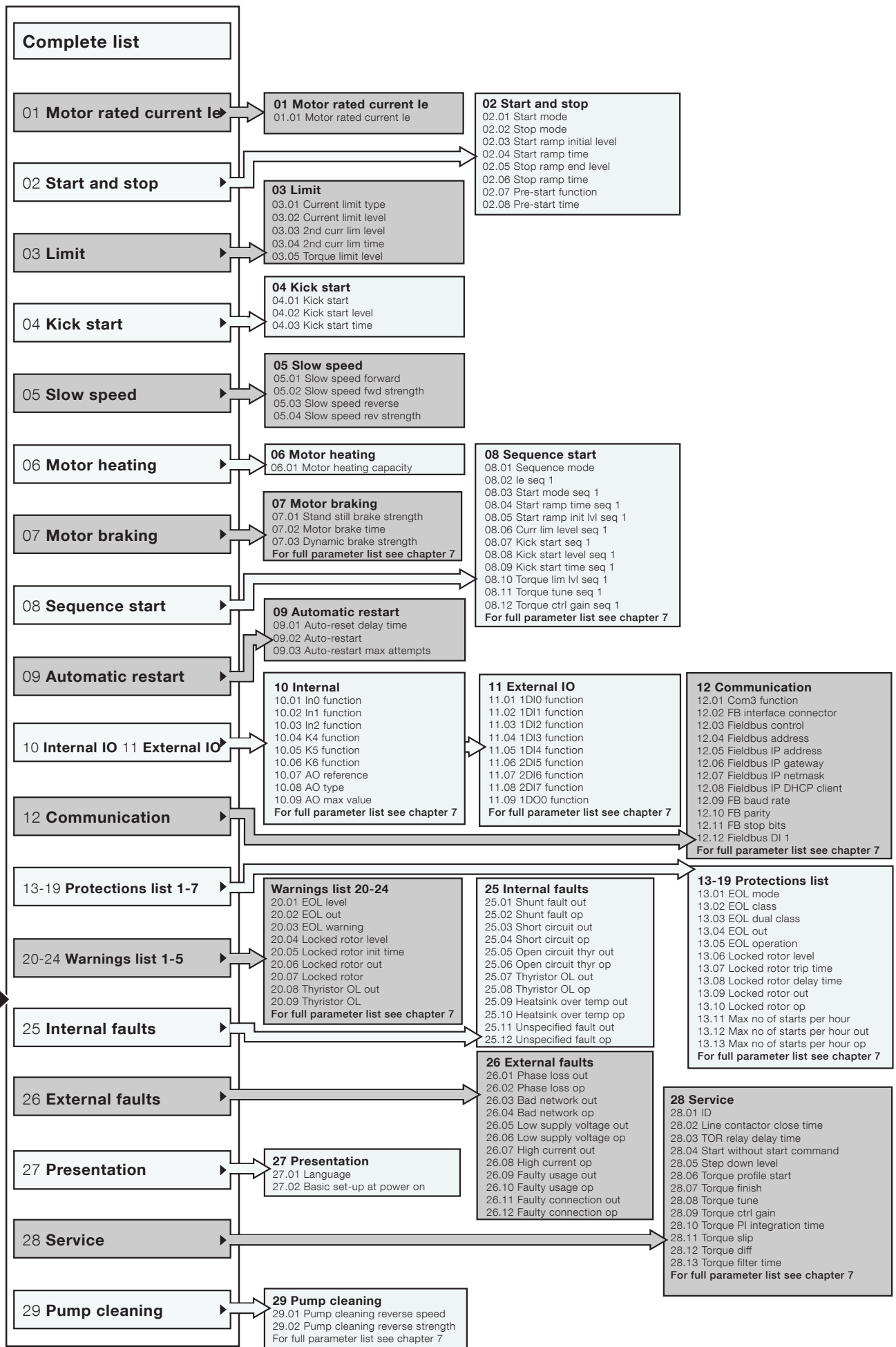
Use the Complete list menu if a more advanced parameter setup is necessary. The complete list menu contains groups of parameters put in function order, such as Start and Stop, Communication etc. For navigation, see **Figure 6.23**.

Use the Navigation keys to navigate the submenu. Push  "Select" to enter a menu. Push  "Save" to save a new setting. Push  "Cancel" to exit a setting without saving. Push  "Back" to go back. For function settings and full parameter list, see chapter **7 Functions**.



**Figure 6.23**  
Complete list navigation





### 6.4.1.2 Favorites

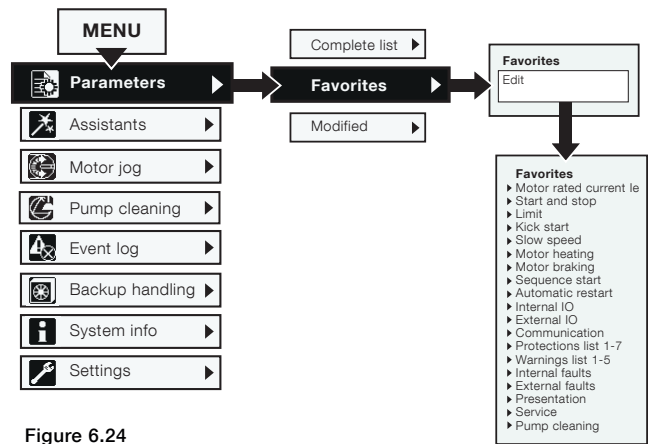
Path in menu:

Menu ▶ Parameters ▶ Favorites

For navigation, see **Figure 6.24**.

In the Favorites menu you can add favorite parameters for quick selection. Select parameters such as Start and stop, Current limit, Kick start, Torque control, etc

1. Push "Select" to enter the Favorites menu and then push "Select" to edit the Favorites list.
2. Use the Navigation keys to select a parameter group. Push "Open" to open the group.
3. Push "Select" to select parameters. A check mark shows in front of the selected parameter. Push "Unselect" to unselect the parameter. Push "Done" to save and exit. See **Figure 6.25**.
4. The selected Favorites show directly in Favorites menu for quick selection. Push "Back" to go back.



**Figure 6.24**  
Favorites navigation



**Figure 6.25**  
Favorites menu

6

### 6.4.1.3 Modified

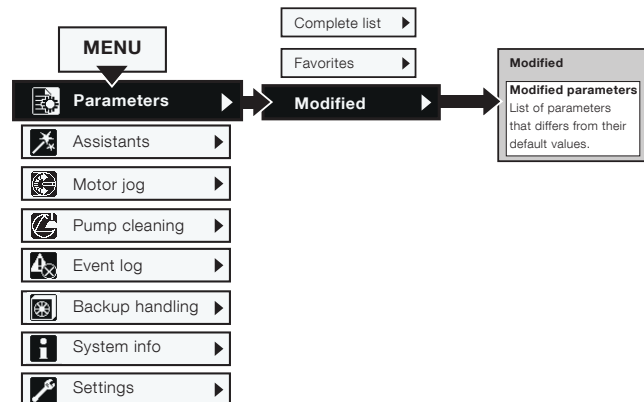
Path in menu:

Menu ▶ Parameters ▶ Modified

For navigation, see **Figure 6.26**.

The Modified menu contains changed parameters that are different from defaults.

Push "Select" and then "Edit" to edit the different parameter. Push "Save" to save and go back. Or push "Cancel" to go back without saving.



**Figure 6.26**  
Modified navigation

## 6.4.2 Assistants

Path in menu:

Menu ► Assistants

For navigation, see **Figure 6.27**.

For more details on how to set Basic set-up and Application set-up, see chapter 2 **Quick start**.

For more information about Assistants and Application list, see **chapter 7.24 Assistants**.

The Assistants menu contains default settings and parameters. Use this menu to set only the necessary parameters before you can start the motor. All necessary input data shows up in an automatic loop. The Assistants menu is divided in:

- **Basic set-up**
- **Application set-up**



### INFORMATION

After you select an application and make your changes, do not select this application again because this resets the application to the default settings.

### Enter the Assistants menu

Push “Menu” and select Assistants with the Navigation keys.

Push “Select” to enter the Assistants menu.

### Basic set-up

Use the Navigation keys to select Basic set-up.

Push “Select” to enter the Basic set-up.

The Basic set-up menu is divided in 5 steps: Language, Date and time, Motor data, System configuration and Setup complete.

### Application set-up

The Application set-up are quick settings for Applications, Values and Tune settings.

Use the Navigation keys to select Application set-up.

Push “Select” to enter the Application set-up.

Select for what type of application you use the Softstarter by pushing “Select”.

See **Figure 6.28**.

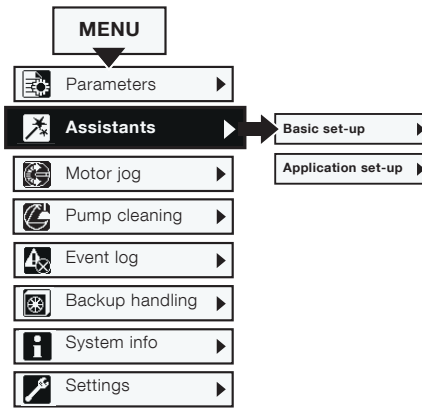


Figure 6.27

Assistants navigation

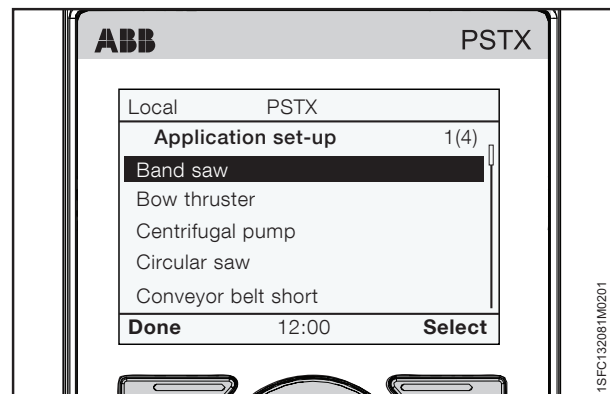


Figure 6.28

Application set-up

### 6.4.3 Event log

Path in menu:

Menu ▶ Event log



For navigation, see **Figure 6.29**.

The Event log menu shows the event log in the Softstarter. The log shows the 100 latest events in chronological order, with “type of event” and date. For details about all events push details. Use navigation keys to view all entries in the event log. The types of event logs are:



- **Faults**
- **Protections**
- **Warnings**
- **Parameter changed**
- **Run**

See **Figure 6.30**.



#### Faults

Use the Navigation keys to select a Fault and push  “Details” to read details about the Fault (Name, On time and Event count). Then push the i-key to see information about the Fault. Push  “Back” to go back to Faults log menu.



#### Protections

Use the Navigation keys to select a Protection and push  “Details” to read details about the Protection (Name, On time and Event count). Push the i-key to see information about the Protection. Push  “Back” to go back to Protections log menu.



#### Warnings

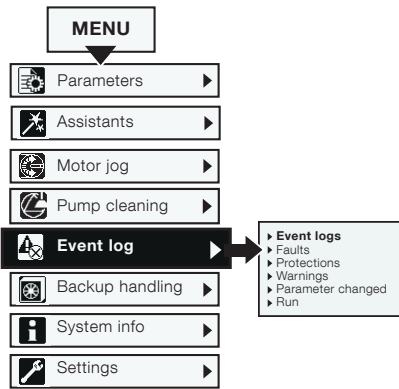
Use the Navigation keys to select a Warning and push  “Details” to read details about the Warning (Name, On time and Event count). Then push the i-key to see further information about the Warning. Push  “Back” to go back to Warning log menu.

#### Parameter changed

Use the Navigation keys to select a parameter and push  “Details” to read details about the changed parameter (Name, On time and Event count). Push  “Back” to go back to Warning log menu.

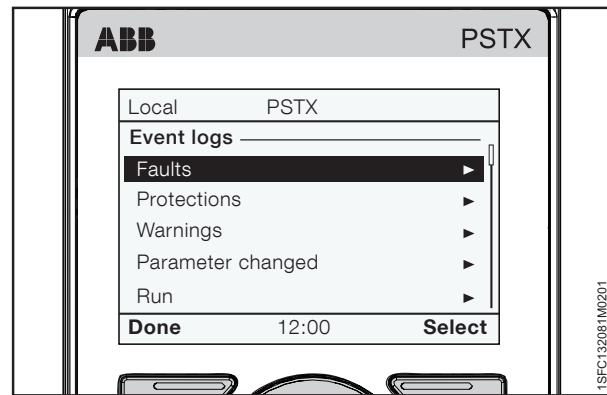
#### Run

Use the Navigation keys to select a run event and push  “Details” to read details about the run event (Name, On time and Event count). Push  “Back” to go back to Warning log menu.



**Figure 6.29**

Event log navigation



**Figure 6.30**

Event log

## 6.4.4 Backup

Path in menu:

Menu ► Backup handling



For navigation, see **Figure 6.31**.

You can use the movable keypad to transfer parameters from one Softstarter to another during commissioning.


### Transfer of parameters

To transfer (or copy) parameters from one Softstarter to another, connect the keypad to the selected Softstarter and follow the instructions in chapter **6.4.4.1 Create backup** and chapter **6.4.4.2 Uploading of parameters** below:

#### 6.4.4.1 Create backup


1. Push  "Select" to enter the Backupmenu.
2. Push  "Create backup" to create a backup.
3. The download of parameters shows as in **Figure 6.32**. The name of the backup file shows as the day, month and year it was created.

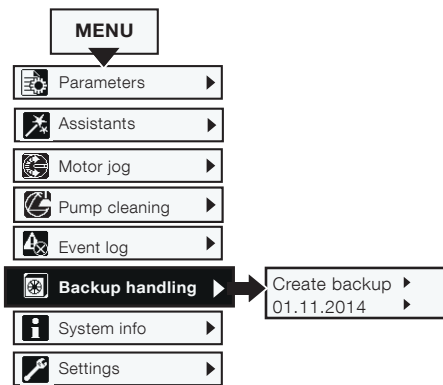
#### Replace backup

The Softstarter can store 2 backups. Use the Navigation keys to select an earlier backup and push  "Replace", to replace a backup.

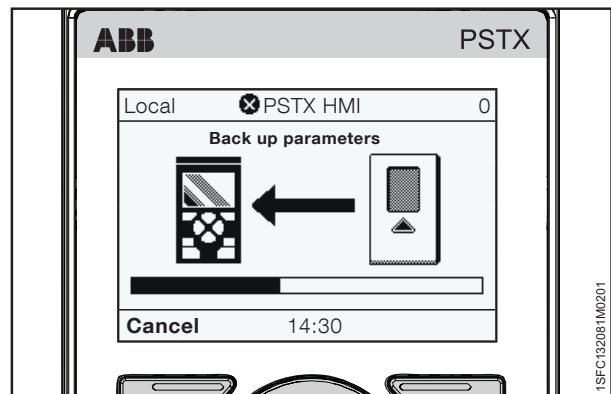
A backup does not change the ID and Motor rated current le.

#### 6.4.4.2 Uploading of parameters

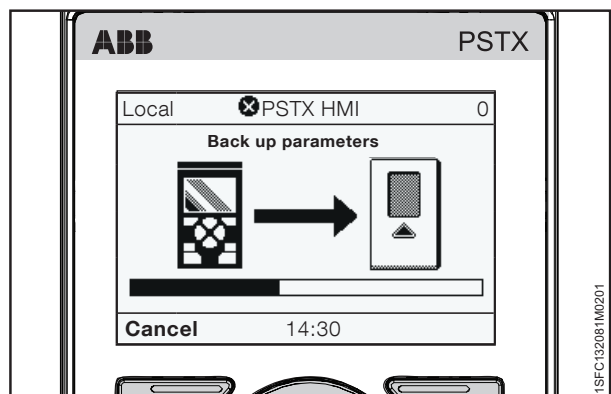
1. When you complete the download of parameters, remove the HMI from the Softstarter.
2. Connect the HMI to the Softstarter that must receive the backup.
3. Enter the Backup menu and use the Navigation keys to select the backup.
4. Push  "Select" for the upload of the parameters. This shows as in **Figure 6.33**.



**Figure 6.31**  
Backups handling



**Figure 6.32**  
Downloading parameters





**Figure 6.33**  
Uploading parameters

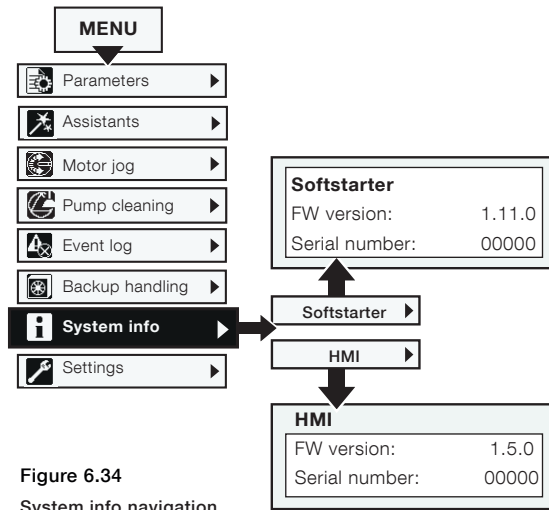
## 6.4.5 System info

Path in menu:

Menu ► System info

For navigation, see **Figure 6.34**.

The System info menu contains system info such as Firmware version and Serial number. The System info menu shows system info of the Softstarter and HMI. Push  “Select” to enter the System info menu. Use the Navigation keys to make your selection. Push  “Back” to go back.



**Figure 6.34**  
System info navigation

## 6.4.6 Settings

Path in menu:

Menu ► Settings

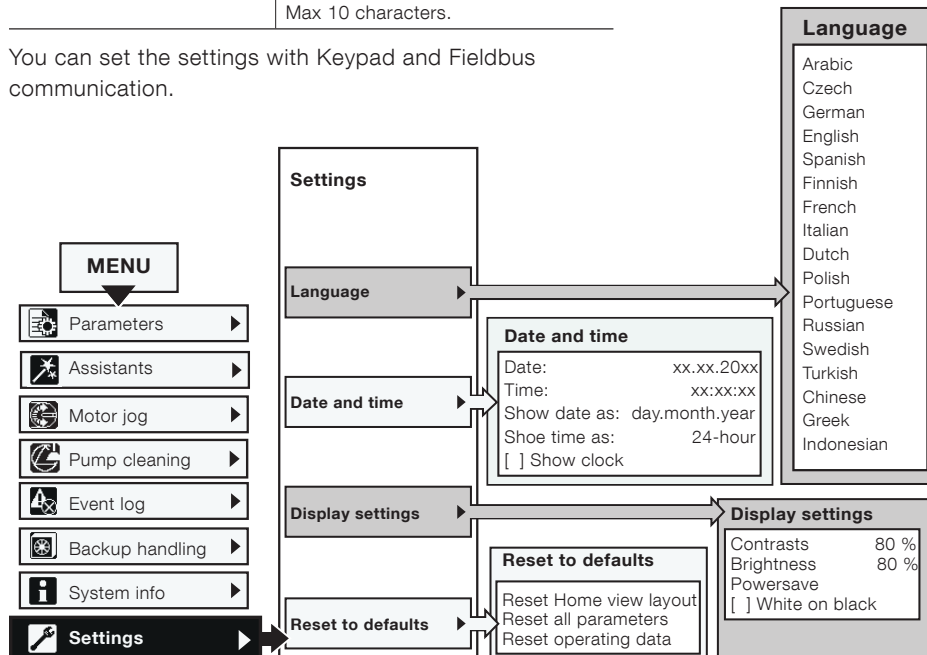
For navigation, see **Figure 6.35**.

The settings menu contains Softstarter set-up parameters. The settings are given in these chapters:

**Table 6** Settings menus

Chapter	Description
6.4.6.1 Language	Change language of the HMI
6.4.6.2 Date and time	Set date and time for the Softstarter
6.4.6.3 Display settings	Change Contrast, brightness etc.
6.4.6.4 Reset to defaults	Reset Home view layout Reset all parameters Reset operating data
6.4.6.5 Change HMI heading	The HMI heading is displayed in the status bar at the top of the HMI. Max 10 characters.

You can set the settings with Keypad and Fieldbus communication.



**Figure 6.35**  
Settings navigation







### 6.4.6.1 Language

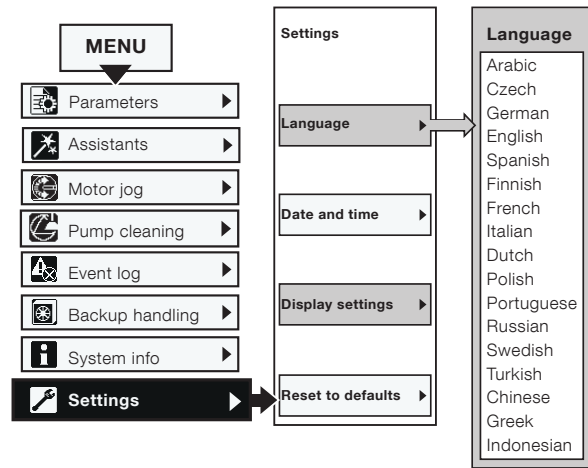
Path in menu:

Menu ► Settings ► Language

For navigation, see **Figure 6.36**.

Follow the instructions below for access to the language settings menu (start from Home view):

1. Push  “Select” to enter the menu.
2. Use Navigation keys to navigate to the Settings menu. (The icon symbol is a wrench).
3. Push  “Select” to enter the Settings menu. Use Navigation keys to navigate to the Settings menu. (The icon symbol is a wrench).
4. Highlight the first alternative and push  “Select” and then “Edit” to enter Language settings.
5. Use  and  to select language  
See **Figure 6.37**.
6. Push  “Save” to save the selected language.



**Figure 6.36**  
Language navigation



**Figure 6.37**  
Language menu

### 6.4.6.2 Date and time

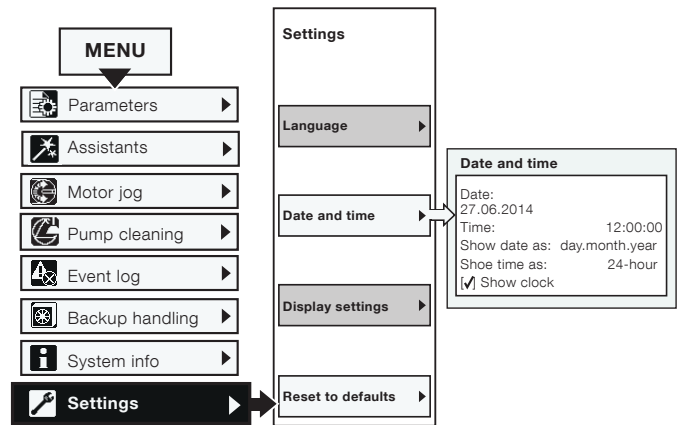
Path in menu:

Menu ► Settings ► Date and time

For navigation see **Figure 6.38**.

Date and Time settings include all date and time configurations for the Softstarter.

To change the settings in the Date and Time menu, push “Edit” to enter the setting. Push “Save” to save the set value. See **Figure 6.39**.



**Figure 6.38**  
Date and time

**Table 7** Date and time settings

Option	Function
Date	Set date: Day, month and year.
Time	Set time: Hour, minutes and seconds.
Show date as	Show the date at top level in this format: CE day . month . year US month/day/Year SO year-month-day
Show time as	Show the time in 12-hour or 24-hour
Show clock	Show clock On / Off



**Figure 6.39**  
Date and time menu

### Real time clock

The Real time clock is the local time in the Softstarter. The clock runs 2 hours after control supply power is turned off. Set date and time again if a longer power failure occurs.

When the configuration of the time setting is completed, push “Back” 3 times to go back to the Home view, top level.

### 6.4.6.3 Display settings

Path in menu:

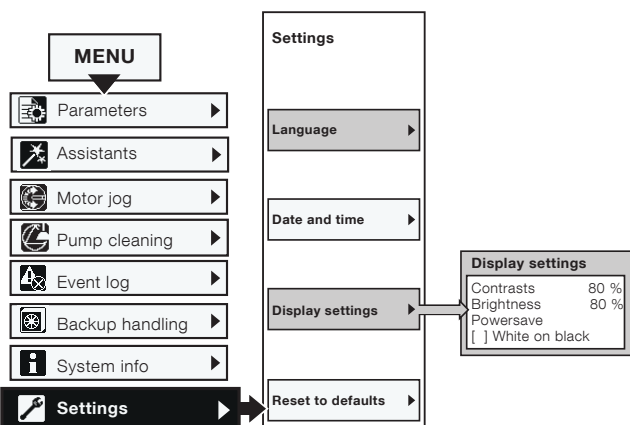
Menu ► Settings ► Display settings

For navigation, see **Figure 6.40**.

The Display settings include all display configurations of the Softstarter. To change the Display settings, Push “Edit” to enter the setting level. Push “Save” to save the set value.

**Table 8** Display settings

Option	Function
Contrast	Set the contrast intensity 0 ... 100%
Brightness	Set the brightness intensity 0 ... 100%
Power save	Turn off the display backlight after 30 minutes, 1, 2, or 5 hours or Never
White on black	White on black display On / Off



**Figure 6.40**  
Display settings



#### 6.4.6.4 Reset to defaults




Path in menu:

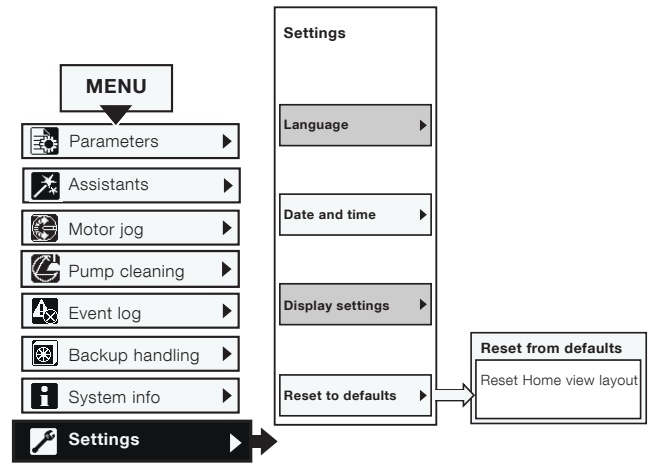
Menu ► Settings ► Reset to defaults

For navigation, see **Figure 6.41**.

Use the Reset to defaults menu to reset home view layout, parameters or operating data back to factory default settings.

The reset does not change the real time clock, the hour run meter, the number of starts and the presentation language.

1. Push  "Select" to enter the Reset to defaults menu.
2. Use the Navigation keys to select;  
Home view layout  
Parameters  
Operating data
3. Push  "Select" to select the data which must be reset.
4. Push  "Yes" to reset, or push "No" to cancel.
5. Confirmation of reset shows as "Done" on the screen.





**Figure 6.41**  
Reset to defaults

#### Reset operating data

Reset operating data is divided in:

- Active energy
- Reactive energy
- Number of starts
- Motor run time
- Thyristor run time

Use the Navigation keys to select which data to reset. Push  "Reset" to reset, or push  "Back" to go back to Reset to defaults menu.

Confirmation of reset shows as "Done" on the screen.

6

# 7 Functions

<b>7.1 Introduction</b>	74
7.1.1 Setting parameters	74
7.1.2 Softstarter states	74
7.1.3 Motor Current le	75
<b>7.2 Voltage ramp</b>	76
7.2.1 Voltage start ramp	76
7.2.2 Voltage stop ramp	77
7.1.1 Setting parameters	74
<b>7.3 Torque ramp</b>	78
7.3.1 Torque start ramp	79
7.3.2 Torque stop ramp	80
<b>7.4 Full voltage start</b>	81
<b>7.5 Direct stop</b>	81
<b>7.6 Stand still brake</b>	82
<b>7.7 Current limit</b>	83
<b>7.8 Kick start</b>	84
<b>7.9 Slow speed</b>	85
<b>7.10 Motor heating</b>	86
<b>7.11 Motor braking</b>	86
<b>7.12 Sequence start</b>	89
<b>7.13 Automatic restart</b>	90
<b>7.14 Inputs/outputs</b>	91
7.14.1 Signal priority order	92
7.14.3 Relay outputs	94
7.14.4 Analog output	95
7.14.5 Temperature sensor	96
<b>7.16 Event groups</b>	101
<b>7.17 Protections</b>	102
<b>7.18 Warnings</b>	101
<b>7.19 Faults</b>	119
<b>7.20 Special feature</b>	124
<b>7.21 Pump cleaning</b>	128
<b>7.23 SettingsFast take off</b>	133129
<b>7.24 AssistantsSettings</b>	133
<b>7.25 Complete parameter listAssistants</b>	132130
<b>7.25 Complete parameter list</b>	132132

This chapter contains descriptions of all the Softstarter functions and the parameters for configuration.

## 7.1 Introduction

### 7.1.1 Setting parameters

#### Set the parameters via HMI

With the HMI Keypad, you can set parameters for each item, or as a selection of default parameters for different applications.

The HMI complete list shows all parameter groups:

---

01 Motor rated current Ie
02 Start and stop
03 Limit
04 Kick start
05 Slow speed
06 Motor heating
07 Motor braking
08 Sequence start
09 Automatic restart
10 Internal IO
11 External IO
12 Communication
13 ... 19 Protections list 1-7
20 ... 24 Warnings list 1-5
25 Internal faults
26 External faults
27 Presentation
28 Service
29 Pump cleaning

---

For navigation sheets, see chapter 6.4.1 Parameters.



#### Lock/Unlock parameters

Push and hold the Options -key, Menu-key and i-key simultaneous for 2 seconds in order to lock / unlock the keypad.

This prevents accidental changes of parameters. Parameters are read-only. Still Start / Stop and R/L is active.

#### Set the parameters via Fieldbus/PLC

When Fieldbus is used, you can change parameters from the PLC.

A different document specification shows more details about parameter settings changed through Fieldbus/PLC, see **chapter 8 Communication**.

### 7.1.2 Softstarter states

The Softstarter has multiple operation states, in which different functions are available.

Functions can operate in one or more Softstarter states. If a function does not operate in all states, this is noted in the respective function description.

The Softstarter has these states:

- Individual function
- Stand by
- Pre-start
- Start ramp
- TOR (Top of ramp)
- Stop ramp

#### Individual function

In Individual function state, the Softstarter runs individual functions.

Individual functions are:

- Motor heating
- Stand-still brake
- Slow speed forward
- Slow speed reverse

#### Stand by

In Stand by state the Softstarter runs no functions except diagnostics.

#### Pre-start

In Pre-start state the Softstarter runs functions that are intended to run before the Softstarter goes into Start ramp state. A pre start function runs during a pre-set time. Then the Softstarter continues to Start ramp state:

Pre-start functions are:

- Motor heating
- Stand-still brake
- Slow speed forward
- Slow speed reverse

The pre-start functions can also be run as individual functions.

### Start ramp

In Start ramp state the Softstarter runs one of the start functions to soft start a motor by controlling the output voltage or torque. The Start ramp ends and goes into Top of ramp state when the output voltage comes at 100% voltage.

Available start functions are:

- Voltage start ramp
- Torque start ramp
- Full voltage start ramp

### Top of ramp

When the motor comes at Top of ramp, (100% motor voltage) the Softstarter closes the bypass and does not control the motor. In Top of ramp state the Softstarter only runs diagnostics.

### Stop ramp

In Stop ramp state the Softstarter runs stop functions to soft stop a motor by controlling the output voltage or torque. The stop ramp state ends and goes into stand by state when the output voltage comes at the pre-set Stop ramp end level.

Available stop functions are:

- **No ramp**
- **Voltage stop ramp**
- **Torque stop ramp**
- **Dynamic brake**

## 7.1.3 Motor Current Ie

Set the motor current when you install the Softstarter.

This is the rated nominal current of the motor.



#### **WARNING**

All PSTX Softstarters must be set to the rated current of the motor.

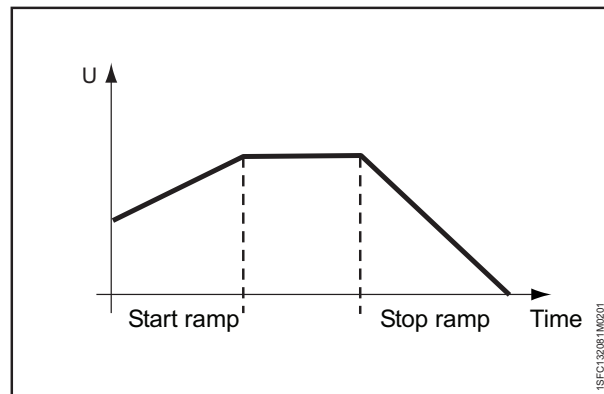
#### **Configuration of the Motor Current Ie with these parameters:**

Parameter	Description	Setting range	Default value
01.01 Motor Current Ie	Set the nominal current of the motor. For good performance it is important that it is set to the correct value. For Inside Delta connection, set this parameter to 58% of the nominal motor current.	Individual (type related)	30 A...1250 A, divided into 19 overlapping ranges

## 7.2 Voltage ramp

When using the Voltage ramp, the voltage increases linearly from Initial start level to full voltage during start, and decreases linearly from the Step down level to Stop end voltage level during stop, see **Figure 7.1**.

The torque not always follows the voltage curve, because the torque is also subject to the current. This has the effect that the torque does not increase or decrease linearly.



**Figure 7.1**  
Start and stop ramp

### 7.2.1 Voltage start ramp

When the Softstarter receives a start signal, the Softstarter quickly increases the voltage to the Start ramp initial level. The Softstarter then controls the output voltage in a start ramp.

When the output voltage comes at Top of ramp, the Softstarter closes the bypass, see **Figure 7.2**.

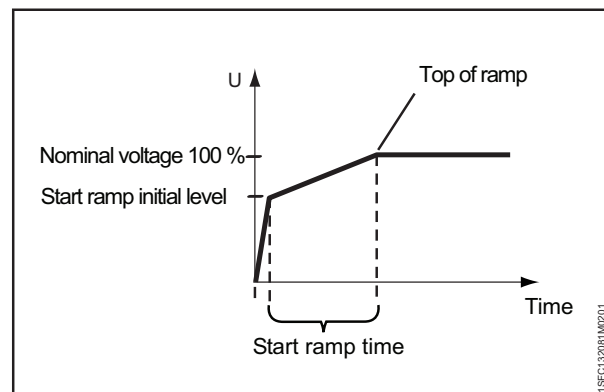
To come at Top of ramp these conditions are necessary:

- The Start ramp time passed, i.e. 100% output voltage.
- The current is below  $1.2 \times$  nominal motor current.

The Start ramp time is the time it takes to go from Start ramp initial level to full voltage. The time to come at Top of ramp can be longer than the set Voltage ramp time, because this is subject to the current.

If the motor starts with a very heavy load, the start ramp time can be longer than usual.

Example: If the Start ramp time is set to 2 seconds and the motor starts a heavy load, this can cause the output current to not go below the set 120% of nominal motor current when the pre-set start ramp time is reached.



**Figure 7.2**  
Voltage start ramp

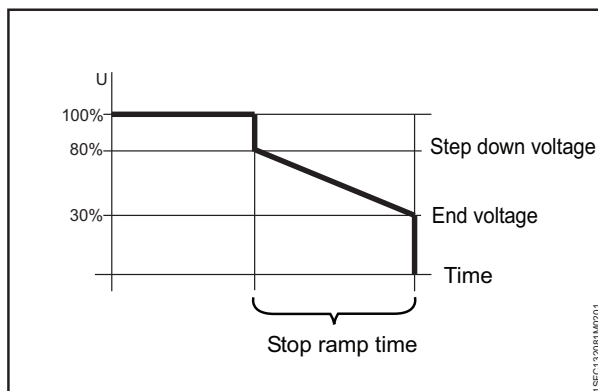
Configuration of the Voltage start ramp with these parameters:

Parameter	Description	Setting range	Default value
02.01 Start mode	Set the Start mode to Voltage ramp.	Voltage ramp, Torque ramp, Full voltage ramp	Voltage ramp
02.03 Start ramp Initial level	Set the voltage level from where the start ramp initiates	10 ... 99%	30%
02.04 Start ramp time	Set the effective time it takes for the voltage to reach 100%.	1 ... 120 s	10 s

## 7.2.2 Voltage stop ramp

When the Softstarter receives a stop signal, the Softstarter decreases the output voltage to the motor in a quick stop ramp, from full voltage down to set Step down voltage level. For best performance, set the step down level to 80%.

When step down level is reached, the Softstarter controls the output voltage during preset Stop ramp time to End voltage level and cuts the output voltage to the motor, see **Figure 7.3**.



**Figure 7.3**  
Voltage stop ramp

### Configuration of the Voltage stop ramp with these parameters:

Parameter	Description	Setting range	Default value
02.02 Stop mode	Set to voltage ramp.	No ramp, Voltage ramp, Torque ramp, Dynamic brake	No ramp
02.05 Stop ramp end level	Sets the level from where the stop ramp ends and the power to the motor is cut (voltage level for Voltage stop and torque level for Torque stop).	10 ... 99%	30%
02.06 Stop ramp time	Sets the effective time it takes for the voltage to come at end level	1 ... 120 s	10 s
28.05 Step down level	Sets the level from where the stop ramp initiates.	10 ... 100%	80%

## 7.3 Torque ramp

When using the Torque ramp, the Softstarter controls the output voltage so that the output torque follows a specified optimal torque curve during start and stop ramp.

For Torque start ramp there are 4 different adjustable torque curves. See description of torque profile parameters for examples on when to use which curve.

The curves are:

- Constant
- Linear
- High inertia
- Progressive

When using the Torque start ramp, the acceleration is constant if the set torque curve is the same as the actual load curve. The output voltage does not increase linearly like when using the voltage start ramp, see **Figure 7.4**.

The Torque ramp makes the equipment that the motor drives stop much softer than the Voltage start ramp.

For Torque stop ramp there is one fixed torque curve. This fixed torque curve is optimized for pump applications.

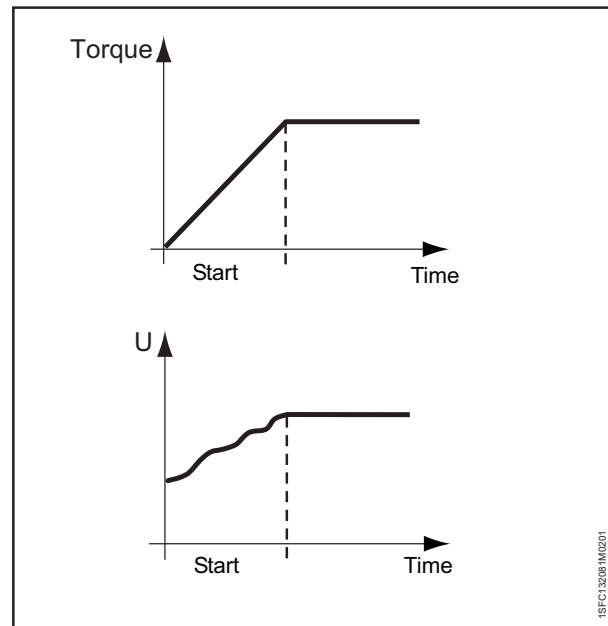


Figure 7.4  
Torque start ramp



### 7.3.1 Torque start ramp

When the Softstarter receives a start signal, the Softstarter makes a quick ramp to set Start ramp initial level. Then the Softstarter controls the output voltage so that the output torque follows a specified optimal torque curve during pre-set time to 100% nominal torque.

When the output voltage comes at 100% nominal voltage (Top of ramp), the Softstarter closes the bypass.

To come at Top of ramp these conditions need to be met:

- The output voltage comes at 100% nominal voltage.
- The current is below  $1.2 \times$  nominal motor current.

The time between the start signal and when nominal torque is reached is the start ramp time.

The start ramp time can be longer if the motor starts with a very heavy load.

Example: If the Start ramp time is set to 2 seconds and the motor starts with a heavy load. This can cause that the output current does not go below set 120% of nominal motor current when the pre-set start ramp time is reached.

#### Configuration of the Torque start ramp with these parameters:

Parameter	Description	Setting range	Default value
02.01 Start mode	Set to Torque ramp.	Voltage ramp, Torque ramp, Full voltage start	Voltage ramp
02.03 Start ramp Initial level	Sets the torque level from where the start ramp initiates.	10 ... 99%	30%
02.04 Start ramp time	Sets the time it takes for the voltage to come at 100%.	1 ... 120 s	10 s
03.05 Torque limit level	Sets the limit for the torque during soft start with torque control	20 ... 200%	150%
28.06 Torque profile start	Sets the shape of the torque ramp during start. <ul style="list-style-type: none"> <li>• Constant setpoint is for centrifuge</li> <li>• Linear is for compressor</li> <li>• High inertia curve is for long conveyor belts</li> <li>• Progressive curve is for centrifugal pump</li> </ul>	Constant setpoint, Linear ramp, Progressive curve, High inertia curve	Linear ramp
28.07 Torque finish	Sets the operation torque for Torque start ramp setting in percentage of base torque.	30 ... 500%	100%
28.08 Torque tune	Sets the integration time of PI controller.	0 ... 1000%	100%
28.09 Torque ctrl gain	Sets the speed of the voltage regulator during torque start and stop. It seldom needs to be changed, but if a dip occur in the torque curve during stop, increasing this value might solve it.	0.01 ... 10.00	0.02
28.10 Torque PI integration time	Sets the integration time of PI controller.	0.001 ... 10.000 s	0.004 s
28.11 Torque slip	Sets the slip difference from nominal to pull-out torque in percentage.	0.1 ... 100%	1.0%
28.12 Torque diff	Sets the maximum desired difference between reference and actual torque in percentage.	0.1 ... 100%	2.0%
28.13 Torque filter time	Sets the Torque control filter time in seconds.	0.01 ... 10 s	0.02 s

## 7.3.2 Torque stop ramp

When using the Torque stop ramp, the output voltage to the motor the torque follows a specified optimal curve from the Step down level to end voltage during stop. The Torque stop ramp makes the equipment that the motor drives stop much softer than when using voltage ramp. See **Figure 7.5**.

This can be especially useful in pump applications where a sudden stop can cause water hammering and pressure surges.

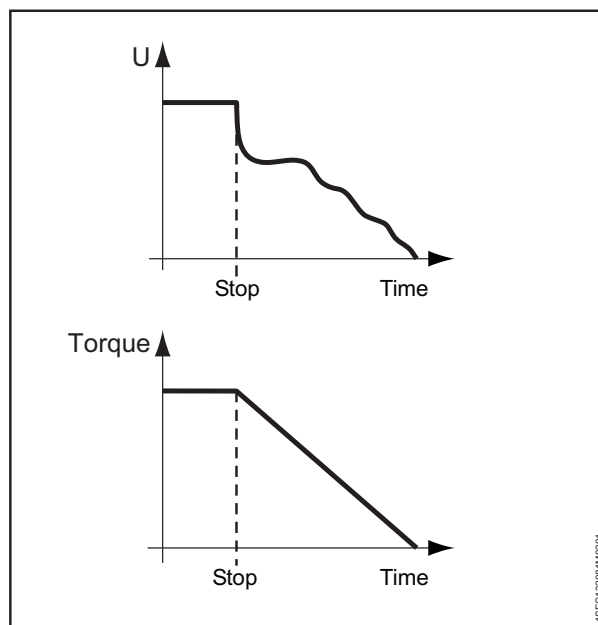


Figure 7.5

Torque stop ramp

7

### Configuration of the Torque stop ramp with these parameters:

Parameter	Description	Setting range	Default value
02.02 Stop mode	Set to Torque ramp.	No ramp, Voltage ramp, Torque ramp, Dynamic brake	No ramp
02.05 Stop ramp end level	Sets the level from where the stop ramp ends and the power to the motor is cut(voltage level for Voltage stop and torque level for Torque stop).	10 ... 99%	30%
02.06 Stop ramp time	Sets the time it takes for the voltage to come at end level.	1 ... 120 s	10 s
28.05 Step down level	Sets the level from where the stop ramp initiates.	10 ... 100%	80%
28.08 Torque tune	Sets the adjustment of resistive losses.	0...1000%	100%
28.09 Torque ctrl gain	Sets the speed of the voltage regulator during torque start and stop. It seldom needs to be changed, but if a dip occur in the torque curve during stop, increasing this value might solve it.	0.01 ... 10	0.02
28.10 Torque PI integration time	Sets the integration time of PI controller.	0.001 ... 10 s	0.004 s
28.11 Torque slip	Sets the slip difference from nominal to pull-out torque in percentage.	0.1 ... 100%	1.0%
28.12 Torque diff	Sets the maximum desired difference between reference and actual torque in percentage.	0.1 ... 100%	2.0%
28.13 Torque filter time	Sets the Torque control filter time in seconds.	0.01 ... 10 s	0.02 s

## 7.4 Full voltage start

When using the full voltage start, the Softstarter increases the motor speed as fast as possible. The motor voltage ramps up to full voltage in ½ seconds.



### INFORMATION

Full voltage start ignores the Current limit.

Configuration of the Full voltage start with these parameters:

Parameter	Description	Setting range	Default value
02.01 Start mode	Set to Full voltage start.	Voltage ramp, Torque ramp, Full voltage start	Voltage ramp

## 7.5 Direct stop

When using the Direct stop the output voltage to the motor is 0.

Configuration of the Direct stop with these parameters:

Parameter	Description	Setting range	Default value
02.02 Stop mode	Set to No ramp.	No ramp, Voltage ramp, Torque ramp, Dynamic brake	No ramp

## 7.6 Stand still brake

The Stand-still brake function brakes the motor. Use this during pre-start to make sure that the motor does not run before you start the Start ramp. You can also control the Stand-still brake from a digital I/O or a Fieldbus.



### WARNING

If the Softstarter is connected inside-delta, use of the Stand-still brake can cause damage to the equipment.



### WARNING

Because this function makes the motor warm, we recommend to use a PTC or PT100 element to monitor the temperature.

In some conditions, the built-in EOL is not accurate for this feature.



### INFORMATION

Stand-still brake only works when the Softstarter is connected in-line.

### Configuration of the Stand-still brake with these parameters:

7

Parameter	Description	Setting range	Default value
02.07 Pre-start function	Set to Stand-still brake.	Pre start off, Motor heating, Stand still brake, Slow speed forward, Slow speed reverse	Pre start off
02.08 Pre-start time	Set the duration of the pre-start function.	0.0 ... 7200.0 s	10.0 s
07.01 Stand still brake strength	Set the Braking strength 10-100%. Select a suitable value for the application.	10 ... 100%	50%

## 7.7 Current limit

Current limit sets a maximum value of the starting current output to the motor. The time to come at full voltage can be longer than the set Start ramp Time when Current limit is enabled.

There are 3 different Current limit functions:

- Normal current limit
- Dual current limit
- Ramp current limit



### WARNING

If the load is very heavy, current limit can prevent the current to decrease below the set current level and cause overheating.

#### Normal current limit

When using Normal current limit and the set current limit is reached, the output voltage stays stable until the current level falls below the set current limit. Then the start ramp continues.

#### Dual current limit

Dual current level has 2 current limit levels. When the Current limit is reached, the output voltage stay constant until the set time expires or the current decreases. If the current decreases, the Softstarter continues the voltage ramp. If the second current limit time expires and the current has not decreased, the Softstarter increases the current to the Dual current limit. See **Figure 7.6** . When the current comes at the Dual current limit the Softstarter behaves as for normal Current limit.

Dual current limit can be used as a back-up function to prevent overheating.

#### Ramp current limit

When the current comes at the first current limit level the output voltage restricts the current from increasing at a maximum linearly curve up to the second current limit. The set time determines the time it takes for the current limit to come at the second current level.

When the current comes at the second current limit, the Softstarter behaves as for the normal current limit.

You can use Ramp current limit as a back-up function to prevent overheating.

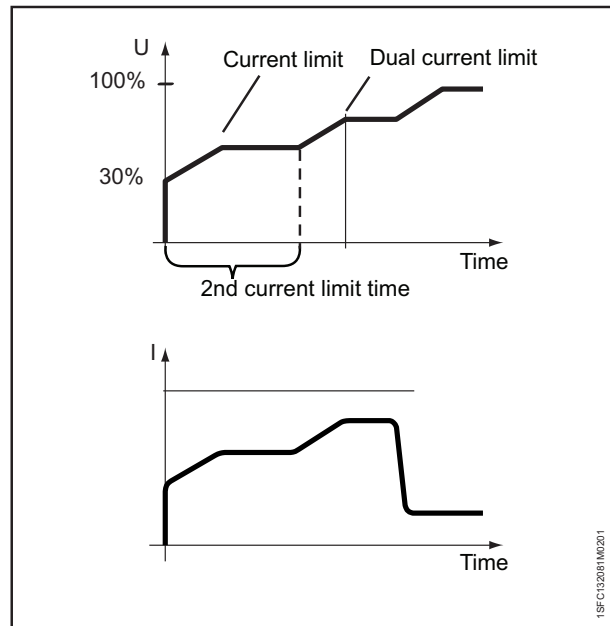


Figure 7.6

Dual current limit

### Current limit has these parameters:

Parameter	Description	Setting range	Default value
03.01 Current limit type	Set the Current limit type.	Off, Normal, Dual, Ramp	Normal
03.02 Current limit level	Sets the first level to which the current is limited during start.	$1.5 \dots 7.5 \times I_e$	$4.0 \times I_e$
03.03 2nd curr lim level	Sets the level of the second current limit.	$1.5 \dots 7.5 \times I_e$	$7.0 \times I_e$
03.04 2nd curr lim time	Sets the time limit from the start signal when the second current limitation comes in operation.	2 ... 120 s	8 s

## 7.8 Kick start

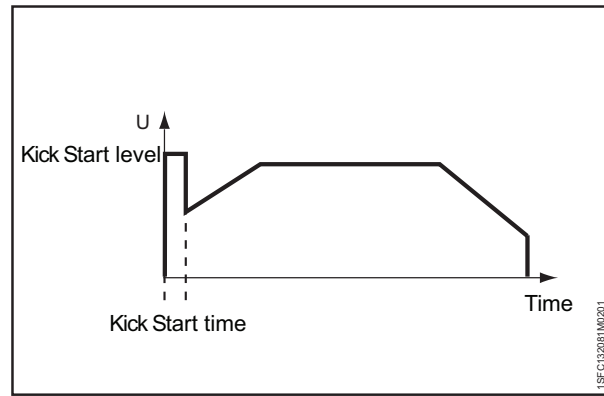
Kick start function is a function to kick loose the motor initial friction during a set time and level.  
If Kick start is enabled, the start ramp starts directly after Kick start.

See **Figure 7.7** .



### INFORMATION

Current limit function does not work during kick start.



**Figure 7.7**  
Kick start

### Kick start has these parameters:

Parameter	Description	Setting range	Default value
04.01 Kick start	Enables a voltage peak at the beginning of the start ramp.	On, Off	Off
04.02 Kick start level	Sets the level of the Kick start in percentage of rated voltage.	50 ... 100%	70%
04.03 Kick start time	Sets the duration of the Kick start in seconds.	0.20 ... 2.00 s	0.20 s

## 7.9 Slow speed

Slow speed is an individual function, or a pre-start function to run the motor with low voltage output. You can use this feature for example to position a traverse or mill band.

Operate this function through the HMI, I/O or Fieldbus.

Slow speed has 3 pre-specified speeds:

- Fast jog
- Jog
- Creep

The motor strength can be adjusted with separate parameters. Select a suitable value for the application.



### WARNING

The torque when using Slow speed is maximum  $\frac{1}{3}$  of the full motor torque. This is achieved when using Fast jog and the strength parameter set to 100%. Too high value of the motor strength could cause oscillations and if set to too low value, the motor may not start.



### WARNING

Because Slow speed function warms up the motor we recommend to use a PTC or PT100 element for temperature monitoring.

In some conditions, the built-in EOL is not accurate for this feature.

You can run the motor in the forward and reverse direction, with different slow speed speeds in each direction. When the Softstarter receives a Slow speed signal, the motor accelerates up to a constant speed that is slower than the nominal speed, for as long as the slow speed signal remains active. When the Slow speed signal is deactivated, the Softstarter immediately cuts the voltage applied to the motor and the motor stops. For navigation, see **6.2.4 Motor jog**.

### Slow speed is configured with the following parameters:

Parameter	Description	Setting range	Default value
02.07 Pre-start function	Set to Slow speed forward or Slow speed reverse.	Pre start off, Motor heating, Stand still brake, Slow speed forward, Slow speed reverse	Pre start off
02.08 Pre-start time	Sets the duration of the pre-start function.	0.0 ... 7200.0 s	10.0 s
05.01 Slow speed forward	Sets the Slow speed forward. Fast jog forward is 33%, Jog forward is 15% and Creep forward is 8% of the nominal motor speed.	Fast jog, Jog, Creep	Jog
05.02 Slow speed forward strength	Parameter related to the torque that is generated during Slow speed in the forward direction.	10 ... 100%	50%
05.03 Slow speed reverse	Sets the Slow speed reverse. Fast jog reverse is 33%, Jog reverse is 20% and Creep reverse is 9% of the nominal motor speed.	Fast jog, Jog, Creep	Jog
05.04 Slow speed rev strength	Parameter related to the torque that is generated during Slow speed in the reverse direction.	10 ... 100%	50%



### INFORMATION

Do not use slow speed for more than 2 minutes, as this will cause the motor to heat up excessively.



### INFORMATION

Slow speed is only working when the Softstarter is connected in-line.

## 7.10 Motor heating

Use the Motor heating as a pre-start function to heat the motor before actual start without rotation to the motor. Or use it as an individual function operated from a digital input or Fieldbus.

The Softstarter supplies a current to the motor, without coming at the torque level that starts the motor.



### WARNING

If the Softstarter is connected inside-delta and using the Motor heating, this can cause damage to the equipment.



### WARNING

Because Motor heating function warms up the motor we recommend to use a PTC or PT100 element for temperature monitoring.

In some conditions the built-in EOL is not accurate for this feature.



### INFORMATION

Motor heating only works when the Softstarter is connected in-line.

7

#### Motor heating has these parameters:

Parameter	Description	Setting range	Default value
02.07 Pre-start function	Set to Motor heating.	Pre start off, Motor heating, Stand still brake, Slow speed forward, Slow speed reverse	Pre start off
02.08 Pre-start time	Sets the duration of the pre-start function.	0.0 ... 7200.0 s	10.0 s
06.01 Motor heating capacity	Sets the heating power to the motor. Select a suitable value for the application.	10 ... 100000 W	10 W



## 7.11 Motor braking

### Stand still brake

Stand still brake prevents a motor from spinning when in standstill condition. It can be activated through IO, fieldbus or as a pre-start function.

### Dynamic brake

Dynamic brake is an intelligent variant of DC brake starting with a period of dynamic braking followed by a switch to DC brake. During the dynamic brake the firing angle and thyristor firing sequence are continuously recalculated depending on operating conditions. During DC brake these are pre-determined. The reason for switching to DC brake is because it is effective at low speed but ineffective at high speed. During both dynamic- and DC-brake the kinetic energy of the motor is converted to heat that is dissipated in the rotor.

Motor braking with Softstarter is not an exact science. Trial and error testing is required to find the optimal parameter values.



#### WARNING

Braking exerts a lot of stress on the thyristors so from a thermal perspective a brake shortly after a start can be counted as two consecutive starts.

If the dynamic brake strength is set close to 100% the current can reach peak level above the motor's locked rotor current. This means that the internal thyristor overload fault or electronic overload protection can trip.



#### INFORMATION

Using a Softstarter to brake the motor will cause noise and vibrations just like any other braking method. If a fast stop time is required the brake strength will have to be set to a large value which will result in increased noise and vibration.



#### INFORMATION

Parameter 07.03 (Dynamic brake strength) and 07.04 (DC brake strength) are the ones that affect the motor deceleration time. Parameter 07.02 (Motor brake time) only works as a timeout. The goal should be to choose the lowest possible braking strength and still fulfill the user's deceleration time requirements.



#### INFORMATION

To use Dynamic brake set parameter 02.02 (Stop mode) to Dynamic brake.



#### INFORMATION

An external PTC or PT100 sensor to monitor the motor temperature is recommended. Does now work when connected Inside delta - see **Figure 5.1**.



#### INFORMATION

Motor heating only works when the Softstarter is connected in-line.

### 7.11.2.1 How to use

Parameter 7.3 (Dynamic brake strength) and 7.4 (DC brake strength) are the ones that affect the motor deceleration time. Parameter 7.2 (Motor brake time) only works as a timeout. The goal should be to choose the lowest possible braking strength and still fulfill the user's deceleration time requirements.

1. Set parameter 2.2 (Stop mode) to Dynamic brake.
2. Set parameter 7.2 (Motor brake time) to be equal to the desired stop time.
3. Set parameter 7.3 (Dynamic brake strength) to 40%.
4. Set parameter 7.4 (DC brake strength) to 40%.
5. Perform the first test and do two measurements:
  - 5.1 Time it takes for the motor to decelerate from full speed to the value specified by parameter 7.5 (DC brake switch speed threshold, default value is 28%).
  - 5.2 Time it takes for the motor to decelerate from full speed to near zero speed.
6. Check if motor deceleration time is longer or shorter than desired.
  - 6.1 If deceleration time is longer than desired, increase dynamic brake strength and DC brake strength by 10% and try again. Continue like this until the actual stop time is equal to the desired stop time.
  - 6.2 If deceleration time is shorter than desired, decrease dynamic brake strength and DC brake strength by 10% and try again. Continue like this until the actual stop time is equal to the desired stop time.
7. Optional configuration: It can be heard when the DC brake is activated, the motor will sound different then. If DC brake is activated too soon (before the motor speed is below the value specified by parameter 7.5), increase parameter 7.6 (DC brake switch delay time) by 5-10s and try again.
8. Optional configuration: If it takes too long time for the motor to decelerate when DC brake is active, increase the motor brake time by 10s and increase only parameter 7.4 (DC brake strength) by 10% and try again.
9. Optional configuration: One of the digital inputs In0, In1 or In2 can be configured as "Cancel brake". When a logic high (flank) is detected, the motor brake will be cancelled.

### 7.11.2.2 How long time does it take to stop the motor?

Depends on the moment of inertia of the motor and load.

Field test example: Motor: 61A, 400V, 50Hz; Load: Fan, large flywheel. With stop mode equal to no ramp, the deceleration time was 1min.

With stop mode equal to dynamic brake and dynamic brake strength and DC brake strength equal to 40%, the deceleration time was 30s.

With dynamic brake strength and DC brake strength equal to 50%, the deceleration time was 20s.

Motor braking has these parameters:

Parameter	Description	Setting range	Default value
07.01 Stand still brake strength	Sets the braking strength, choose suitable value for application.	10–100%	50%
07.02 Motor brake time	Sets the motor brake time.	1.0–900.0 s	1.0 s
07.03 Dynamic brake strength	Sets the Dynamic braking strength.	10–100%	40%
07.04 DC brake strength	Sets the DC braking strength.	10–100%	40%
07.05 DC brake switch speed threshold	The approximate speed when the switch from dynamic brake to DC brake occurs.	10–100%	28%
07.06 DC brake switch delay time	Sets the time that the speed has be below the threshold before the switch to DC brake occurs. Configure this parameter only if the switch occurs too soon or too late.	0.1–100.0 s	3.0 s
02.02 Stop mode	Sets the desired stop mode: No ramp = Immediately cuts power to the motor, Voltage stop ramp = Decreases voltage linearly, Torque stop ramp = Decreases torque in a pre-defined pattern, Dynamic brake = Applies brake to the motor	No ramp, Voltage ramp, Torque ramp, Dynamic brake	No ramp
28.52 Auxiliary condition	Enables additional thyristor trig occasions of dynamic brake	Off, On	Off
28.55 Fast take-off	Reduces the time from the start signal to the current starts flowing in the main circuit.	Off, On	Off
28.63 Flux support min speed	Minimum estimated speed for allowing additional flux supporting current pulses to motor during dynamic brake	10–100%	35%

## 7.12 Sequence start

The Softstarter can start up to 3 different motors sequentially, sequence 1, 2 and 3. This is suitable when setting up the Softstarter with different applications. Select the parameter set through input signal to the Softstarter.

Parameter settings and physical connections for programmable inputs must agree.



### WARNING

EOL does not work during Sequence start. Recommended to add separate overload protections for each motor.

For connections, see chapter **5.1.2.5 Programmable inputs (Sequence start)**.

Parameters set for sequence start 1, 2 and 3 are equal.

If the Softstarter trips, and the trip must stop the motor, all motors stop.

Sequence start has these parameters:

*Example: Start 1, (Start mode seq 1) is set to Run 1 relay, (K4, K5 or K6) the relay closes when the start signal is given, which leads to a power transfer. This can change between Softstarters and their specific parameter settings.*

Parameter	Description	Setting range	Default value
08.01 Sequence mode	Enable sequence start of motors.	Off, Start several motors	Off
08.02 I <sub>e</sub> seq 1 08.30 seq 2 08.60 seq 3	Sets the nominal current for the motor. For good performance, it is important that the nominal current is set to the correct value. For Inside Delta connection, set this parameter to 58% of the nominal motor current.	Individual (different for each type)	9.0 A...1250 A, divided into 19 overlapping ranges
08.03 Start mode seq 1 08.31 seq 2 08.61 seq 3	Sets the desired start mode.	Voltage ramp, Torque ramp, Full voltage start	Voltage ramp
08.04 Start ramp time seq 1 08.32 seq 2 08.62 seq 3	Sets the time it takes for the voltage to come at 100%.	1 ... 120 s	10 s
08.05 Start ramp init lev seq 1 08.33 seq 2 08.63 seq 3	Sets the level from where the start ramp initiates (voltage level for Voltage start and torque level for Torque start).	10 ... 99%	30%
08.06 Curr lim lev seq 1 08.34 seq 2 08.64 seq 3	Sets the level to which the current is limited during start.	0.5 ... 7.5 × I <sub>e</sub>	7.0 × I <sub>e</sub>
08.07 Kick start seq 1 08.35 seq 2 08.65 seq 3	Enables a voltage peak at the beginning of the start ramp.  Information: The function Current Limit is not in operation during Kick start.	Off, On	Off
08.08 kick start level seq 1 08.36 seq 2 08.66 seq 3	Sets the level of the Kick start in percentage of rated voltage.	50 ... 100%	70%
08.09 Kick start time seq 1 08.37 seq 2 08.67 seq 3	Sets the duration of the Kick start in seconds.	0.20 ... 2.00 s	0.20 s
08.10 Torque lim lvl seq 1 08.38 seq 2 08.68 seq 3	Sets the level to which the torque is limited during the start with torque control.	20 ... 200%	150%
08.11 Torque tune seq 1 08.39 seq 2 08.69 seq 3	Adjustment of resistive losses.	0 ... 1000%	100%
08.12 Torque ctrl gain seq 1 08.40 seq 2 08.70 seq 3	Sets the speed of the voltage regulator during torque start and stop. It seldom needs to be changed, but if a dip occur in the torque curve during stop, increasing this value might solve it.	0.01 ... 10.0	0.02

## 7.13 Automatic restart

The Softstarter automatically starts the motor again after a fault or protection occurred.



### INFORMATION

Automatic restart does not work for:

Shunt fault, Short circuit fault, Open circuit thyristor fault, Faulty usage, Faulty connection, Electronics failure, Max number of starts, Phase reversal protection, Bypass open protection, Auto restart protection and IO Controller protection.

The primary requirement is that if a fault or protection was asserted, the Softstarter automatically starts the motor again in order to ensure an uninterrupted process.

The event only resets after the Auto-reset delay time passed. If Auto-restart is enabled, the Softstarter does not start the fault relay directly, because the fault relay can sometimes be connected to a breaker upstream.

The Softstarter makes multiple attempts to start again, with a fixed time interval between each, and ignores the start digital input signal during this time.

If the fault still remains after a restart, this is a failed attempt to start again.

The fault relay is only on after the number of failed restarts is higher than the given number.

Upon a stop signal the auto-restart sequence is aborted and the fault relay is off.

The programmable options are:

- None - No function on the digital input.
- Reset - Fault/protection reset.
- Enable - When In0=0, the Softstarter stops immediately. When In0=1, the Softstarter is in normal operation. Overrides all other inputs, except LOCAL CONTROL.
- Slow speed forward - While the digital input is high, the motor will slowly move forward.
- Slow speed reverse - While the digital input is high, the motor will slowly move in the reverse direction.
- Motor heating - While the digital input is high, the motor heating is active.
- Stand still brake - While the digital input is high, the stand still brake is active.
- Start reverse - While the digital input is high, the Softstarter will start in the reverse direction, using external reversing contactors.
- User defined protection - When activated (the protection can be programmed to be active low or high) the User defined protection will be activated.
- Emergency mode - Active high, Emergency mode is activated when digital input is high. - Active low, Emergency mode is activated when digital input is low.
- Fieldbus disable control - When the digital input is set high, the motor cannot be controlled from the fieldbus. Instead the start/stop digital input must be used, or the HMI.
- Start 1 - Start motor 1. See chapter 7.12 Sequence start.
- Start 2 - Start motor 2. See chapter 7.12 Sequence start.
- Start 3 - Start motor 3. See chapter 7.12 Sequence start.
- Switch to remote control - A positive flank from low to high on digital input takes the control from the HMI, i.e. local control is changed to remote control.
- **Cancel brake,**  
Pump cleaning automatic,  
Pump cleaning forward,  
Pump cleaning backward,  
Hold in Remote (Active High),  
Hold in Remote (Active Low).
- Hold in Remote (Active High) - Then the digital input is set high the control from HMI, i.e. local control is changed to remote control and can not be changed back to local as long as the digital input is high.
- Hold in Remote (Active Low) - The same as above except that is is active low instead of active high.

7

**Automatic restart has these parameters:**

Parameter	Description	Setting range	Default value
09.01 Auto-reset delay time	Delay time after which the event is reset.	0 ... 3600 s	10 s
09.02 Auto-restart	Enable auto-restart function.	Off,On	Off
09.03 Auto-restart max attempts	Max number of auto-restart attempts.	1 ... 10	5

## 7.14 Inputs/outputs

This chapter gives a description of input and output signals (I/O) such as digital inputs, relay outputs, analog outputs, temperature inputs, and external digital inputs.

Chapter	Function
7.12.1	Digital inputs
7.12.2	Relay outputs
7.12.3	Analog outputs
7.12.4	Temperature sensor

### Internal I/O

Internal I/O are the integrated signals to the Softstarter.

The internal I/O provides these:

- 5 Digital inputs
- 3 Relay output
- 1 Analog output

### Extension I/O (Option)

The Softstarter can be extended with more inputs and outputs by using the I/O Extension module. The I/O Extension module provides these:

- 8 Digital input
- 4 Relay output
- 1 Analog output

To use an extension I/O provides the same possibilities to use all the Softstarters functions as for the programmable internal I/O.

Available I/O Extensions. See chapter **5.1.3 Extension I/O**.

For example, an extension I/O is useful when a sequence start is necessary.

### Connect the I/O Extension

- Set parameter Com3 function (12.01) to the I/O Extension.
- Connect the DX111 or the DX122 1Ca and 1Cb to Com3 terminals.
- Use parameter group 11 to program the function of each DX111/DX122 input and output.

**External digital inputs (extension I/O) have these parameters:**

Parameter	Description	Setting range	Default value
12.01 Com3 function	Set the function of the Com3 port to Extension I/O	None, Test, modbus RTU slave, Extension I/O.	Test

## 7.14.1 Signal priority order

The default priority order for all signals is HMI, fieldbus and then wired input.

### Detailed list of signal priorities:

Input	HMI in local control	HMI in remote control
Start <sup>2</sup>	HMI	Fieldbus <sup>1</sup> / Wired
Stop	HMI	Fieldbus <sup>1</sup> / Wired
Reset	All inputs have the same priority	All inputs have the same priority
Enable	Wired	Wired
Slow speed forward <sup>2</sup>	HMI	Fieldbus <sup>1</sup> / Wired
Slow speed reverse <sup>2</sup>	HMI	Fieldbus <sup>1</sup> / Wired
Motor heating <sup>2</sup>	Wired	Fieldbus <sup>1</sup> / Wired
Stand still brake <sup>2</sup>	Wired	Fieldbus <sup>1</sup> / Wired
Start reverse <sup>2</sup>	Wired	Fieldbus <sup>1</sup> / Wired
User defined protection	Wired	Fieldbus <sup>1</sup> / Wired
Emergency mode active high	Wired	Fieldbus <sup>1</sup> / Wired
Emergency mode active low	Wired	Fieldbus <sup>1</sup> / Wired
Fieldbus disable control	Wired	Wired
Start1 <sup>2</sup>	Wired	Fieldbus <sup>1</sup> / Wired
Start2 <sup>2</sup>	Wired	Fieldbus <sup>1</sup> / Wired
Start3 <sup>2</sup>	Wired	Fieldbus <sup>1</sup> / Wired
Switch to remote control	Wired	Fieldbus <sup>1</sup> / Wired
Cancel Brake	Wired	Fieldbus <sup>1</sup> / Wired
Pump cleaning automatic <sup>2</sup>	HMI	Fieldbus <sup>1</sup> / Wired
Pump cleaning forward <sup>2</sup>	HMI	Fieldbus <sup>1</sup> / Wired
Pump cleaning backward <sup>2</sup>	HMI	Fieldbus <sup>1</sup> / Wired
Hold in Remote (Active High)	Wired	Wired
Hold in Remote (Active Low)	Wired	Wired

1) Fieldbus signal is regarded if:

- Wired input "Fieldbus disable control" (see Setting range) is low.
- "Auto Mode" signal on fieldbus is high (Bit 3 in Digital Output Telegram from PLC to the Softstarter)
- Parameter "12.03 Fieldbus Control" is set to On.

2) All wired inputs that are configured as 'Enable' need to be high or this signal is ignored.

## 7.14.2 Digital inputs (DI)

The Softstarter has 5 digital inputs for basic control of the unit.

The 5 digital inputs are terminal 13, 14, 15, 16 and 17.

The inputs are named

- Start
- Stop
- In0
- In1
- In2

Start and Stop inputs are fixed to start and stop function and cannot be changed.

In0, In1 and In2 are programmable inputs. Functions can be related to the physical signal through a drop down menu on the HMI.

Use the inputs with 24 V and current sinking type, 10 mA. The digital input is isolated and can withstand up to 100 V in potential difference between the Softstarter functional ground and the ground of the interconnected system. You can use the input with internal 24 V or external 24 V supply.

The digital input values for respective input voltage:

“0” = 0 – 5 V

“1” = 15 – 33 V

Maximum voltage input is 33 V and minimum is -0.5 V. Outside these voltage ranges the digital value is undefined and can be either “0” or “1”.

### Internal digital Inputs (Internal I/O) have these parameters:

Parameter	Description	Setting range	Default value
10.01 In0 function	Function of programmable digital input.	None, Reset, Enable, Slow speed forward, Slow speed reverse, Motor heating, Stand-still brake, Start reverse, User defined protection, Emergency mode (active high), Emergency mode (active low), Fieldbus disable control, Start 1, Start 2, Start 3, Switch to remote control, Cancel brake, Pump cleaning automatic, Pump cleaning forward, Pump cleaning backward, Hold in Remote (Active High), Hold in Remote (Active Low), Lock Parameters (Active High), Lock Parameters (Active Low).	Reset
10.02 In1 function		Same as In0	None
10.03 In2 function		Same as In0	None

### External digital Inputs (extension I/O) have these parameters:

Parameter	Description	Setting range	Default value
11.01 1DI0 function	Function of programmable digital input.	None, Reset, Enable, Slow speed forward, Slow speed reverse, Motor heating, Stand-still brake, Start reverse, User defined protection, Emergency mode (active high), Emergency mode (active low), Fieldbus disable control, Start 1, Start 2, Start 3, Switch to remote control, Cancel brake, Pump cleaning automatic, Pump cleaning forward, Pump cleaning backward, Hold in Remote (Active High), Hold in Remote (Active Low), Lock Parameters (Active High), Lock Parameters (Active Low).	None
11.02 1DI1 function	Same as 1DI0	Same as 1DI0	None
11.03 1DI2 function	Same as 1DI0	Same as 1DI0	None
11.04 1DI3 function	Same as 1DI0	Same as 1DI0	None
11.05 1DI4 function	Same as 1DI0	Same as 1DI0	None
11.06 2DI5 function	Same as 1DI0	Same as 1DI0	None
11.07 2DI6 function	Same as 1DI0	Same as 1DI0	None
11.08 2DI7 function	Same as 1DI0	Same as 1DI0	None

### 7.14.3 Relay outputs

The Softstarter has 3 relay outputs. The relay outputs are K4, K5 and K6. The relays outputs are: 30VDC/250VAC Ith = 5A , Ie= 1,5Amp (AC-15).

You can set the function of these relay output signals Functions or an event group can be related to the physical signal through a drop down menu on the HMI.

The programmable options for each relays are:

- None – No function on the relay output.
- Run – Indicates when the Softstarter gives voltage to the motor.
- Top of ramp (TOR) – Indicates that motor runs on full voltage.
- Event group (0-6) – Faults, protections, warning are all selectable by customer.
- Sequence 1-3 Run – Used to control the line contactors during sequence start.
- Sequence 1-3 TOR – Used to control the bypass contactors during sequence start.
- Run reverse – Used to close the reversing contactor.
- Ready to Start – Indicates when
  - Control supply voltage is detected
  - Mains three phase voltage is detected
  - Mains frequency is within range (40-72Hz)
  - Motor connection is detected
  - Phase sequence is detected
  - No events are active
  - Enable signal is active
  - If the max nbr of starts per hour function is enabled and set to stop manual or stop automatic, the remaining time to start counter.
- Fieldbus – Control the relay through the fieldbus communication. See the fieldbus manuals for more info.

As default K4 is set to function Run, K5 to Top of ramp and K6 to Eventgroup 0.

Description of the relay terminals

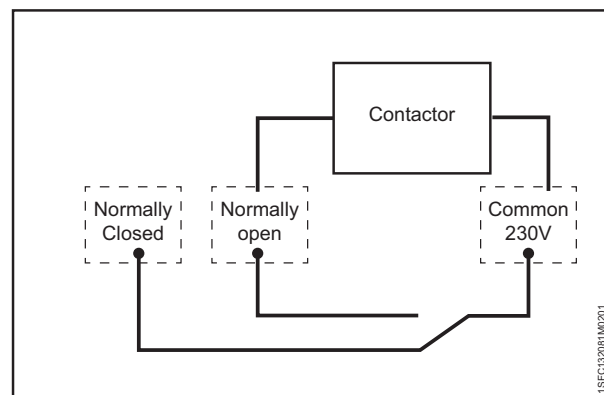
Each relay has 3 terminals: 1 common terminal (COM), 1 normally open terminal (NO) and 1 normally closed terminal (NC). . See **Figure 7.8** .

Normally open – Circuit is open in normal mode (circuit is not shorted to common).

Normally closed – Circuit is closed in normal mode (the circuit is continuously shorted to common).

Internal relay outputs (internal I/O) have these parameters:

Parameter	Description	Setting range	Default value
10.04 K4 function	Function of programmable output relay K4, K5, K6.	None, Run, Top of ramp, Eventgroup 0 -6, Sequence 1-3 Run, Sequence 1-3 TOR, Run reverse, Ready to start, Fieldbus	Run
10.05 K5 function	Same as K4 function	Same as K4 function	Top of ramp
10.06 K6 function	Same as K4 function	Same as K4 function	Event group 0



**Figure 7.8**

A contactor may for example be connected (230 volts)



**External relay outputs (extension I/O) have these parameters:**

Parameter	Description	Setting range	Default value
11.09 1DO0 function	Function of programmable output relay 1DO0 (extension I/O).	None, Run, Top of ramp, Eventgroup 0 -6, Sequence 1-3 Run, Sequence 1-3 TOR, Run reverse, Ready to start, Fieldbus	None
11.10 1DO1 function	Same as 1DO0	Same as 1DO0	Top of ramp
11.11 2DO2 function	Same as 1DO0	Same as 1DO0	Event group 0
11.12 2DO3 function	Same as 1DO0	Same as 1DO0	Motor Current, A

#### 7.14.4 Analog output

The Softstarter has 1 analog output for an analog meter, or the PLC.

Configuration of the parameter analog output type, AO type, to show:

- Motor current, A
- Mains voltage, V
- Active power, kW
- Active power, HP
- Reactive power, kVar
- Apparent power, kVA
- Active energy, kWh
- Reactive energy, kVAh
- $\cos \Phi$
- Motor temperature, %
- Thyristor temperature, %
- Motor voltage, %
- Mains frequency, Hz
- PT100 temperature, centigrade
- PTC resistance, Ohm

The voltage or current output can be set by a configuration parameter, AO reference in the Softstarter. The selection of voltage or current must be set to adapt to the analog meter or the PLC.

The settings are:

- 0-10 voltage output, V
- 0-10 current output, mA
- 0-20 current output, mA
- 4-20 current output, mA

AO is the reference to the output voltage in 0-100% of the set parameter AO max and AO min.

**Internal Analog output has these parameters:**

Parameter	Description	Setting range	Default value
10.07 AO reference	Sets the Analog output reference	0-10 mA, 0-20 mA, 4-20 mA, 0-10 V	4-20 mA
10.08 AO type	Sets the Analog output type.	Motor current [A], Mains voltage [V], Active power [kW], Active power [HP], Reactive power [kVAh], Apparent power [kVA], Active energy [kWh], Reactive energy [kVAh], $\cos \Phi$ , Motor temperature [%], Thyristor temperature [%], Motor voltage [%], Mains frequency [Hz], PT100 temperature [centigrade], PTC resistance [ $\Omega$ ], Fieldbus [%]	Motor current [A]
10.09 AO max value	Sets the max analog output value.	0 ... 1000000	500
10.10 AO min value	Sets the min analog output value.	0 ... 1000000	0

**Example:**

- *AO type is set to Motor current.*
- *AO reference is set to 0-10 V*
- *AO min to 0, and AO max to 3000.*

*This means that when the motor current is:*

- *3000 A, the output voltage is 10 V.*
- *0 A, the output voltage is 0 V.*
- *1500 A, the output voltage is 5 V.*

**External Analog output (Extension I/O) has these parameters:**

Description	Description	Setting range	Default value
11.13 1AO0 reference	Sets the Analog output reference.	0-10 mA, 0-20 mA, 4-20 mA, 0-10 V	4-20 mA
11.14 1AO0 type	Sets the Analog output type.	Motor current [A], Mains voltage [V], Active power [kW], Active power [HP], Reactive power [kVAr], Apparent power [kVA], Active energy [kWh], Reactive energy [kVArh], cos $\Phi$ , Motor temperature [%], Thyristor temperature [%], Motor voltage [%], Mains frequency [Hz], PT100 temperature [centigrade], PTC resistance [ $\Omega$ ], Fieldbus [%]	Motor current [A]
11.15 1AO0 max value	Sets the max Analog output value.	0 ... 1000000	500
11.16 1AO0 min value	Sets the min Analog output value.	0 ... 1000000	0

### 7.14.5 Temperature sensor

Temperature inputs

There is 1 temperature input. The user can set 3 different types of temperature sensors: See **chapter** Temperature sensors 7.17.14

- PTC
- PT100
- Bi-metal switch

These can be connected to different protections.

A protection can come on if a particular temperature occurs.

## 7.15 Fieldbus

PSTX has 1 Anybus port, 1 Fieldbus plug adaptor port (FBPA), and 1 modbus RTU port. You can use only 1 bus at a time: the user cannot connect the Softstarter to multiple Fieldbuses.

The port used for modbus RTU is a multifunction port that you can use to connect an Extension I/O module. If an Extension I/O module is necessary you cannot use the port for modbus RTU. Use an Anybus modbus RTU module instead.

In the IP-based Fieldbuses, such as modbus TCP, the user must set IP address, gateway, subnet mask and DHCP client.

### Fieldbus type

When you use Fieldbus communication, select the present type of Fieldbus:

- Internal Modbus RTU
- Anybus
- Fieldbus plug



### INFORMATION

If there is no message passed between the PSTX softstarter and the Anybus module for more than the configured fieldbus failure timeout time (parameter 19.12), the PSTX softstarter will trip on fieldbus communication failure protection (P1E00) and with the default configuration the motor will be stopped.



### INFORMATION

If the fieldbus communication system is setup in such a way that commands/requests are not continuously passed between the PLC and Softstarter, this protection function should be disabled. Set parameter 19.4 (Fieldbus failure op) to "Off".

### Fieldbus control

If you use the Softstarter with Fieldbus communication, set the Fieldbus interface to ON before it can take action

### Fieldbus address

If you use the Softstarter with Fieldbus communication, set a Fieldbus address for the Softstarter. Select a suitable and unoccupied number as the address.



### WARNING

The motor can start unexpectedly if there is a start signal present during one of the actions below.

- Changing from 1 type of control to another (Fieldbus control / hardwire control).
- Remember that when Fieldbus auto disable is active, this change can occur automatically.
- Re-programming of the programmable inputs.
- Reset all Settings (sets programmable input to Enable).

### Fieldbus failure operation

See chapter 7.17.21 Fieldbus failure protection.

## Fieldbus Inputs/Outputs

Functions set in the Softstarter as Fieldbus digital inputs (DI) are in fact the digital inputs to the PLC i.e. the data flow from the Softstarter through the network to the PLC.

Fieldbus digital outputs (DO) are not configurable. The output (DO) gives a description of data flow from the network to the Softstarter i.e. appears as an input, from the Softstarter point of view.

**Fieldbus communication has these parameters:**

Parameter	Description	Setting range	Default value
12.01 Com3 function	Sets the function of the Com3 port. The default value "Test" is needed during production test. It should be changed to "None" if not Modbus or Extension I/O is used.	None, Test, Modbus RTU slave, Extension I/O	Test
12.02 FB interface connector	Sets the Fieldbus interface selection.	FbPlug, Modbus RTU, Anybus, None	None
12.03 Fieldbus control	Enables control from fieldbus.	Off, On	Off
12.04 Fieldbus address	Sets the Bus address.	0 ... 65535	0
12.05 Fieldbus ip address	Fieldbus IP: Sets the IP-address.	0.0.0.0 ... 255.255.255.255	0.0.0.0
12.06 Fieldbus ip gateway	Fieldbus IP: Sets the default gateway.	0.0.0.0 ... 255.255.255.255	0.0.0.0
12.07 Fieldbus ip netmask	Fieldbus IP: Sets the netmask.	0.0.0.0 ... 255.255.255.255	255.255.255.0
12.08 Fieldbus ip dhcp client	Fieldbus IP: Enables dhcp.	Off, On	Off
12.09 FB baud rate*	Sets the baud rate of internal modbus-RTU interface, Anybus DeviceNet and Anybus modbus-RTU.	1200, 2400, 4800, 9600, 19200, 38400, 57600, 76800, 115200, 125000, 250000,500000, auto	* 19200
12.10 FB parity	Sets parity for Anybus modbus-RTU.	No parity, Odd parity, Even parity	Even parity
12.11 FB stop bits	Select stop bits for Anybus modbus-RTU.	1 Stop bit, 2 Stop bits	1 Stop bit

Parameter	Description	Setting range	Default value
12.12 Fieldbus DI 1	Sets the DI 1 programmable digital input signal.	None, Start feedback, Stop feedback, Fault reset feedback,	Run status
12.13 Fieldbus DI 2	Sets the DI 2 programmable digital input signal.	Slow speed rev feedback, Slow speed forw feedback, Start 1 feedback, Start 2 feedback,	TOR status
12.14 Fieldbus DI 3	Sets the DI 3 programmable digital input signal.	Start 3 feedback, Motor heating feedback, User defined feedback,	Line
12.15 Fieldbus DI 4	Sets the DI 4 programmable digital input signal.	Stand still brake feedback, Emergency mode feedback,	Phase sequence
12.16 Fieldbus DI 5	Sets the DI 5 programmable digital input signal.	Start reverse feedback, Run status, TOR status, Line,	Start feedback
12.17 Fieldbus DI 6	Sets the DI 6 programmable digital input signal.	Phase sequence, Event group 0 status, Event group 1 status,	Stop feedback
12.18 Fieldbus DI 7	Sets the DI 7 programmable digital input signal.	Event group 2 status, Event group 3 status, Event group 4 status, Event group 5 status,	Event group 0 status
12.19 Fieldbus DI 8	Sets the DI 8 programmable digital input signal.	Event group 6 status, Sequence 1 Run status, Sequence 2 Run status, Sequence 3 Run status,	Event group 1 status
12.20 Fieldbus DI 9	Sets the DI 9 programmable digital input signal.	Sequence 1 TOR status, Sequence 2 TOR status, Sequence 3 TOR status,	Event group 2 status
12.21 Fieldbus DI 10	Sets the DI 9 programmable digital input signal.	Run reverse status, Enable status, Digital In0 status, Digital In1 status, Digital In2 status, Local control status, Cancel brake status, Pump cleaning auto status, Pump cleaning forward status, Pump cleaning backward status, External digital 1DI0 status, External digital 1DI1 status, External digital 1DI2 status, External digital 1DI3 status, External digital 1DI4 status, External digital 2DI5 status, External digital 2DI6 status, External digital 2DI7 status, HW DI Start status, HW DI Stop status, Ready to start (line contactor)	Event group 3 status
12.22 Fieldbus AI 1	Sets the AI 1 programmable analog input signal.	None, Phase L1 current, Phase L2 current, Phase L3 current,	Phase L1 current
12.23 Fieldbus AI 2	Sets the AI 2 programmable analog input signal.	Active power (HP), Active power, Apparent power, Mains voltage, Power factor, Motor voltage,	Phase L2 current
12.24 Fieldbus AI 3	Sets the AI 3 programmable analog input signal.	Active energy (resettable), EOL time to trip, Mains frequency,	Phase L3 current
12.25 Fieldbus AI 4	Sets the AI 4 programmable analog input signal.	Max phase current, Motor current, Motor run time (resettable), Motor temperature, Motor temperature percent, Number of starts (resettable), Phase sequence, PT100 temperature, PTC resistance, Reactive energy (resettable), Reactive power, Remaining time to start, Thyristor temperature, Thyristor temperature percent, EOL time to cool, Top event code, Motor current percent, Thyristor run time (resettable), Motor connection,	Max phase current
12.26 Fieldbus AI 5	Sets the AI 5 programmable analog input signal.	Phase L1 current (high range), Phase L2 current (high range), Phase L3 current (high range), Active power (HP) (high range), Active power (high range), Apparent power (high range), Reactive power (high range), Max phase current (high range), Motor current (high range), Active energy (high range), Reactive energy (high range), Number of starts (high precision)	Mains frequency
12.27 Fieldbus AI 6	Sets the AI 6 programmable analog input signal.		Motor voltage
12.28 Fieldbus AI 7	Sets the AI 7 programmable analog input signal.		Motor temperature percent
12.29 Fieldbus AI 8	Sets the AI 8 programmable analog input signal.		Number of starts (resettable)
12.30 Fieldbus AI 9	Sets the AI 9 programmable analog input signal.		Motor run time (resettable)
12.31 Fieldbus AI 10	Sets the AI 10 programmable analog input signal.		Top event code
12.32 Allow CIP reset	Sets if CIP reset is allowed or not	Yes, No	No

Parameter	Description	Setting range	Default value
12.33 Fieldbus BACnet Device Instance	Fieldbus BACnet Device Instance	0 ... 4194303	4194303
12.34 BACnet FDR IP address	DBACnet foreign device registration IP address	0.0.0.0 ... 255.255.255.255	0.0.0.0
12.35 BACnet foreign device registration UDP port	BACnet foreign device registration UDP port	1 ... 65535	47808
12.36 BACnet foreign device registration time interval	BACnet foreign device registration time interval	0 ... 65535 s	0 s
12.37 Fieldbus AO 1	Sets the AO 1 programmable analog output signal	FBT argument 2, Internal analog out	FBT argument 2
12.38 Fieldbus AO 2	Sets the AO 2 programmable analog output signal	FBT argument 3, External analog out	FBT argument 3
12.39 Change SNMP community string	Change the Profinet SNMP default community strings (both read-only and read-write)	Yes, No	No
12.40 SNMP community string part 1	Profinet SNMP community string part 1	0 ... 4294967295	1094861357
12.41 SNMP community string part 2	Profinet SNMP community string part 2	0 ... 4294967295	1347638360

\*) Restrictions on which baud rates you can use for different protocols.

Baudrate	Modbus RTU on Com 3	Modbus RTU Anybus	Devicenet on Anybus
1200		x	
2400		x	
4800		x	
9600	x	x	
19200	x	x	
38400	x	x	
57600	x	x	
76800	x	x	
115200	x	x	
125000			x
250000			x
500000			x
Auto baud			x

## 7.16 Event groups

An event group consists of a number of supervision functions that have been assigned to it.

There are three different types of supervision functions:

- Faults, default Eventgroup 0 (0000001)
- Protections, default Eventgroup 1 (0000010)
- Warnings, default Eventgroup 2 (0000100)

The supervision functions generate events based on different conditions in the motor and in the Softstarter itself. Each different event can be assigned to 1 or more Event groups. An Event group can be mapped to a relay output or/and a Fieldbus signal.

For each supervision function there is a parameter for assigning the related event to 1 or more Event groups.

In PSTX there are 7 Event groups, numbered from 0 to 6. All supervision functions are set as default to 1 Event group.

There are 7 event groups that you can use in any way. Event groups 4-6 are completely unassigned by default and are convenient to use for custom applications. The other groups have events assigned to them by default.

### Example:

In this example the user collects all internal faults in the event group 6 and connects the event group to relay output K6. The faults are connected to event group 0 by default (indicated with value 0000001). The new value (1000001) assigns the fault to both event group 0 and event group 6.

### Parameter Default value New value :

Parameter	Default value	New value
25.01 Shunt fault out	0000001	1000001
25.03 Short circuit out	0000001	1000001
25.05 Open circuit thyr out	0000001	1000001
25.07 Thyristor OL out	0000001	1000001
25.09 Heat sink over temp out	0000001	1000001
25.11 Unspecified fault out	0000001	1000001
25.13 Electronics failure out	0000001	1000001
10.06 K6 function	Event group 0	Event group 6

## 7.17 Protections

The Softstarter has a number of protection functions to protect the Softstarter, motor and other equipment.

In addition to the type of operations mentioned below, which are available for all protections, some protections have more options.

Protections can be enabled or disabled by the user. The protection parameters can only be changed if the protection is in operation.

When a protection function senses a risk of damage, the unit does these actions:

- Protection LED comes ON
- The unit shows the type of event
- The unit stores the type of event in the event list

Protections can be set to have automatic reset or manual reset. For every protection, there is a parameter called Operation, which can be set to:

- Stop-Automatic – The engine stops, and resets automatic when the fault condition is inactive \*.
- Stop-Manual – The engine stops, and must be reset manually when the fault condition is inactive \*.
- Off
- Indication

\*) You cannot reset a fault when the fault condition is still active.  
Example: If you set EOL Operation (engine is too warm) to stop-manual, you can only reset the Softstarter when the temperature of the engine has decreased to the correct temperature.

Protections can be set to an Event group by the Out parameter. The Event group can be set for relay output to control other devices in an application

By default all parameters are set to the same Eventgroup.



## 7.17.1 Electronic overload protection

The motor is overloaded because of too high current during a certain time. The Electronic overload protection resets when the motor temperature decreases to 60% of EOL trip level.

**Electronic overload protection has these parameters:**

Parameter	Description	Setting range	Default value
13.01 EOL mode	Set the EOL mode to Normal or Dual.	Normal/ Dual	Normal
13.02 EOL class	Sets the EOL trip class.	10 A, 10, 20, 30	10
13.03 EOL dual class	Sets the protection class used when in top of ramp. This parameter is only applicable when EOL protection mode is set to dual.	10 A, 10, 20, 30	10 A
13.04 EOL out	Identifies the Event groups this protection is part of.	Eventgroup 0 ...6	000010
13.05 EOL operation	Sets the operation of this protection.	Off, Stop-Manual, Stop-Automatic, Indication	Stop-Manual

## 7.17.2 Locked rotor protection

The motor is running stiff.

This protection only operates in the Top of ramp state.

**Locked rotor protection has these parameters:**

Parameter	Description	Setting range	Default value
13.06 Locked rotor level	Set the locked rotor trip level	0.5 ... 8.0 x I <sub>e</sub>	4.0 x I <sub>e</sub>
13.07 Locked rotor trip time	Sets the time that the current is above the trip level to trip.	0.20 ... 10.00 s	1.00 s
13.08 Locked rotor delay time	Sets the time after top of ramp that the protection is enabled.	1.00 ... 30.00 s	5.00 s
13.09 Locked rotor out	Identifies the Event groups this protection is part of.	Eventgroup 0 ... 6	000010
13.10 Locked rotor op	Sets the operation of this protection.	Off, Stop-Manual, Stop-Automatic, Indication	Off

## 7.17.3 Max number of starts per hour protection

Sets the minimum time between 2 consecutive starts.

This protection is connected to the signal Remaining time to start, that you can add in the Home view through the Options menu

**Max number of starts protection has these parameters:**

Parameter	Description	Setting range	Default value
13.11 Max no of starts per hour	Sets the limitation in number of starts per hour. When you set this parameter to 6, the minimum time between starts is 10 minutes, allowing a maximum of 6 starts per hour.	1 ... 100	6
13.12 Max no of starts per hour out	Identifies the Event groups this protection is part of.	Eventgroup 0 ... 6	000010
13.13 Max no of starts per hour op	Sets the operation of this protection.	Off, Stop-Manual, Stop-Automatic, Indication	Off

## 7.17.4 Current underload protection

The motor current is below the specified value.

This protection only operates in the Top of ramp state

**Current underload protection has these parameters:**

Parameter	Description	Setting range	Default value
14.01 Curr underload level	Sets the Current underload trip level.	0.3 ... $0.9 \times I_e$	$0.5 \times I_e$
14.02 Curr underload trip time	Sets the time that the current is below the trip level to trip..	0 ... 30 s	10 s
14.03 Curr underload delay time	Sets the time after Top of ramp that the protection is enabled.	0 ... 30 s	5 s
14.04 Curr underload out	Identifies the Event groups this protection is part of.	Eventgroup 0 ... 6	0000010
14.05 Curr underload op	Sets the operation of this protection.	Off, Stop-Manual, Stop-Automatic, Indication	Off

## 7.17.5 Power factor underload protection

The power factor is below the normal level.

Use the Power factor underload protection to supervise the load of the motor. If the load decreases the power factor also decreases.

7

This protection only operates in the Top of ramp state.

**Power factor underload protection has these parameters:**

Parameter	Description	Setting range	Default value
14.06 Pwr factor underload level	Sets the Power factor underload trip level.	0.00 ... 1.00	0.50
14.07 Pwr factor underload trip time	Sets the time that the Power factor is below the trip level to trip.	0 ... 30 s	10 s
14.08 Pwr factor underload delay time	Sets the time after Top of ramp that the protection is enabled.	0 ... 30 s	5 s
14.09 Pwr factor underload out	Identifies the Event groups this protection is part of.	Eventgroup 0 ... 6	0000010
14.10 Pwr factor underload op	Sets the operation of this protection.	Off, Stop-Manual, Stop-Automatic, Indication	Off

## 7.17.6 Current imbalance protection

This protection senses if there is imbalance in the currents. Correctly all 3 phases have the same current.

This protection only operates in the Top of ramp state.

**Current imbalance protection has these parameters:**

Parameter	Description	Setting range	Default value
14.11 Curr imb level	Sets the permitted Current imbalance level between the phase with the highest current and the phase with the lowest current.	10 ... 80%	80%
14.12 Curr imb trip time	Sets the time that the Current imbalance is below the trip level to trip.	1 ... 30 s	10 s
14.13 Curr imb delay time	Sets the time after Top of ramp that the protection is enabled.	1 ... 30 s	5 s
14.14 Curr imb out	Identifies the Event groups this protection is part of.	Eventgroup 0 ...6	000010
14.15 Curr imb operation	Sets the operation of this protection.	Off, Stop-Manual, Stop-Automatic, Indication	Off

## 7.17.7 Overvoltage protection

This protection senses if the main voltage is too high.

This protection does not operate in the Standby state.

**Overvoltage protection has these parameters:**

Parameter	Description	Setting range	Default value
15.01 Overvoltage level	Sets the Overvoltage trip level.	165 ... 850 V	760 V
15.02 Overvoltage trip time	Sets the time that the voltage is above the trip level to trip.	0.1 ... 100.0 s	1.0 s
15.03 Overvoltage out	Identifies the Event groups this protection is part of.	Eventgroup 0 ... 6	000010
15.04 Overvoltage op	Sets the operation of this protection.	Off, Stop-Manual, Stop-Automatic, Indication	Off

## 7.17.8 Undervoltage protection

This protection only operates in the Top of ramp state.

**Undervoltage protection has these parameters:**

Parameter	Description	Setting range	Default value
15.05 Undervoltage level	Sets the Undervoltage trip level.	165 ... 760 V	165 V
15.06 Undervoltage trip time	Sets the time that the voltage is below the trip level to trip.	0.1 ... 100.0 s	1.0 s
15.07 Undervoltage op	Sets the operation of this protection.	Off, Stop manual, Stop auto, Indication.	Off
15.08 Undervoltage out	Identifies the Event groups this protection is part of.	Eventgroup 0 ... 6	000010

## 7.17.9 Voltage imbalance protection

This protection senses voltage imbalance. Normally there is the same voltage in all 3 phases. If the voltage is different in the phases, the engine can run bumpy.

**Voltage imbalance protection has these parameters:**

Parameter	Description	Setting range	Default value
15.09 Voltage imb level	Sets the permitted voltage imbalance level between the phase with the highest voltage and the phase with the lowest voltage.	1 ... 100%	10%
15.10 Voltage imb out	Identifies the Event groups this protection is part of.	Eventgroup 0 ... 6	0000010
15.11 Voltage imb op	Sets the operation of this protection.	Off, Stop manual, Stop auto, Indication.	Off
15.11 Voltage imb trip time	Sets the time of voltage imbalance in order to trip.	1...100 s	10 s

### 7.17.10 Phase reversal protection

7

This protection senses if the phases are connected incorrectly.

The order in which the phases are connected to the in-stream power has no effect on the Softstarter, but it may be relevant to the motor, which is connected to the Softstarter. The motor can for example run in the wrong direction if the phases are connected incorrectly. This protection senses if the phases are connected in the wrong order and then prevents the engine from starting.

**Phase reversal protection has these parameters**

Parameter	Description	Setting range	Default value
16.01 Phase rev out	Identifies the Event groups this protection is part of.	Eventgroup 0 ... 6	0000010
16.02 Phase rev operation	Sets the operation of this protection.	Off, Stop-Manual, Stop-Automatic, Indication	Off
16.12 Phase rev expected sequence	Expected phase sequence	L1->L2->L3, L1->L3->L2	L1->L2->L3

### 7.17.11 Frequency range protection

Sets the trip level for the frequency.

#### Frequency range protection has these parameters:

Parameter	Description	Setting range	Default value
16.03 Freq range lower trip lvl	Sets the lower trip level for the frequency.	40 ...72 Hz	45 Hz
16.04 Freq range upper trip lvl	Sets the upper trip level for the frequency.	40 ...72 Hz	66 Hz
16.05 Freq range trip time	Sets the time that the frequency is outside the trip range to trip.	0 ... 60 s	5 s
16.06 Freq range out	Identifies the Event groups this protection is part of.	Eventgroup 0 ... 6	0000010
16.07 Freq range operation	Sets the operation of this protection.	Off, Stop-Manual, Stop-Automatic, Indication	Off

### 7.17.12 Bypass open protection

This protection senses if the Bypass contactor or relay did not close when Top of ramp is reached.

Speak to ABB Sales Offices for service.

#### Bypass open protection has these parameters:

Parameter	Description	Setting range	Default value
16.08 Bypass open out	Identifies the Event groups this protection is part of.	Eventgroup 0 ... 6	0000010
16.09 Bypass open operation	Sets the operation of this protection.	Off, Stop-Manual, Stop-Automatic, Indication	Indication
16.13 Bypass open trip time	Sets the time that the bypass contactor may be detected as open before tripping.	1 ... 300 s	10 s

7

### 7.17.13 24V output protection

This protection senses if the 24 V voltage output is overloaded or shorted.

#### 24V output protection has these parameters:

Parameter	Description	Setting range	Default value
16.10 24V output out	Identifies the Event groups this protection is part of.	Eventgroup 0 ... 6	0000010
16.11 24V output operation	Sets the operation of this protection.	Off, Stop manual, Stop auto, Indication.	Indication

## 7.17.14 Temperature sensors

### PTC

The PTC temperature input can measure a motor temperature in the range of -25° to 250°. The PTC measurement obeys the standard for a Mark-A detector. Refer to IEC60947-8.

### PT100

The Softstarter has a 3-wire PT100 input. The trip temperature is set by the user. The maximum trip temperature is 250° and lowest is -25°. The PT100 measurement must have an accuracy of +/-3° with 3 wires measuring if the 3 connecting cables have the same resistance.

### Bi-metal switch

You can combine temperature input with bi-metal switches for detecting overtemperature. These temperature sensors behave like a switch that opens or close at the trip temperature. Each type (NO – normally open or NC – normally closed) is supported. The maximum current through the bi-metal switches is 100 mA.

**External thermal sensor has these parameters:**

Parameter	Description	Setting range	Default value
10.11 Ext therm sensor - ID	Sets the External thermal sensor modes. it is required to change it to the used type of sensor.	No sensor, PTC element, Three-wire PT100, Two-wire PT100, Bimetal switch (NC), Bimetal switch (NO)	No sensor

#### 7.17.14.1 External thermal sensor - PTC/Bi-metal switch protection

The external thermal sensor detected a temperature higher than the trip level. The Softstarter has a temperature input where a PTC element can be connected. See chapter **5.1.2.11 Temperature sensor input**. This can be set to trip if it goes above a certain temperature.

For Bi-metal switch protection: 10.11 = Bimetal switch (NO) or (NC). Use 17.01 and 17.02 to set functionality for the protection

#### Error caused by the line

The error caused by the line resistance is to approximately 2.5 Kelvin per ohm. If you don't know the resistance of the line and you cannot measure it, you can make an estimation of the error caused by the line with

**Table 1 Temperature errors in ohm.**

### Temperature errors in ohm

The table below shows temperature errors in ohms, at an ambient temperature of 20 °C, for different line lengths and conductor cross sections for PT100 sensors. Set this number in parameter 17.03 PT100 2wire res.

**Table 1** Temperature errors in ohm

Line length in m	Wire size mm <sup>2</sup>			
	0.50	0.75	1	1.5
10	0.72	0.48	0.36	0.24
25	1.80	1.20	0.92	0.60
50	3.60	2.40	1.80	1.20
75	5.44	3.60	2.72	1.80
100	7.24	4.84	3.60	2.40
200	15.72	9.68	7.24	4.84
500	36.64	24.32	18.20	12.08

### External thermal sensor - PTC/Bi-metal switch protection has these parameters:

Parameter	Description	Setting range	Default value
17.01 PTC out	Identifies the Event groups this protection is part of.	Eventgroup 0 ... 6	0000010
17.02 PTC op	Sets the operation of this protection.	Off, Stop-Manual, Stop-Automatic, Indication	Off

### 7.17.14.2 External thermal sensor - PT100 protection

The external thermal sensor detected a temperature higher than the trip level.

The Softstarter has a temperature input where a PTC100 element can be connected. See chapter **5.1.2.11**

**Temperature sensor input.** This can be set to trip if it goes above a certain temperature.

### External thermal sensor - PT100 protection has these parameters:

Parameter	Description	Setting range	Default value
17.03 PT100 2wire res	Sets the 2-wire resistance for PT100.	0.0 ... 100.0 Ohm	5.0 Ohm
17.04 PT100 trip temp	Sets the PT100 trip temperature level.	-50° ... 250°	60°
17.05 PT100 PT100 reset temp	Sets the PT100 reset temperature.	-50° ... 250°	40°
17.06 PT100 out	Identifies the Event groups this protection is part of.	Eventgroup 0 ... 6	0000010
17.07 PT100 op	Sets the operation of this protection.	Off, Stop-Manual, Stop-Automatic, Indication	Off

## 7.17.15 User defined protection

You can use a Programmable digital input in combination with an external device/sensor to use your own specified protection. An example is the CEM11-FBP ground fault sensor.

**User defined protection has these parameters:**

Parameter	Description	Setting range	Default value
18.01 User defined DI status	Sets if the signal is active high or active low.	Active low, Active high	Active high
18.02 User defined trip time	Sets the time to trip.	0.0 ... 60.0 s	1.0 s
18.03 User defined out	Identifies the Event groups this protection is part of.	Eventgroup 0 ... 6	0000010
18.04 User defined op	Sets the operation of this protection.	Off, Stop-Manual, Stop-Automatic, Indication	Off

## 7.17.16 Ground fault protection

This protection senses if the absolute value of the sum of the 3 line currents is too high, which indicates that there is a ground fault.

7

Note that the currents measurement in the Softstarter is not accurate or fast enough to protect people. The only purpose of this function is to protect equipment.

**Ground fault protection has these parameters:**

Parameter	Description	Setting range	Default value
18.05 Ground fault trip time	Sets the trip time for the ground fault protection.	0.1 ... 10.0 s	0.5 s
18.06 Ground fault out	Identifies the Event groups this protection is part of.	Eventgroup 0 ... 6	0000010
18.07 Ground fault op	Sets the operation of this protection.	Off, Stop-Manual, Stop-Automatic, Indication	Off

## 7.17.17 Too long current limit protection

This protection sense if the current limit is longer in operation than the set trip time. The starting condition is too heavy for the set current limit.

**Too long current limit protection has these parameters:**

Parameter	Description	Setting range	Default value
18.08 Too long curr lim trip time	Sets the trip time for the too long time at current limit protection.	1 ... 600 s	10 s
18.09 Too long curr lim out	Identifies the Event groups this protection is part of.	Eventgroup 0 ... 6	0000010
18.10 Too long curr lim op	Sets the operation of this protection.	Off, Stop-Manual, Stop-Automatic, Indication	Off



## 7.17.18 Too long start time protection

Too long start time protection

**Too long start time protection has these parameters:**

Parameter	Description	Setting range	Default value
18.11 Too long start trip time	Trip time in seconds.	1.0 ... 500.0 s	500.0 s
18.12 Too long start out	Specifies the Event groups this protection belongs to.	Eventgroup 0 ... 6	0000010
18.13 Too long start op	Sets the operation of this protection.	Off, Stop-Manual, Stop-Automatic, Indication, Fast ramp	Off

## 7.17.19 Auto restart protection

Auto restart protection

**Auto restart protection has these parameters:**

Parameter	Description	Setting range	Default value
18.14 Auto restart max delay	Max restart time in seconds	2 ... 3600 s	3600 s
18.15 Auto restart time-out out	Specifies the Event groups this protection belongs to.	Eventgroup 0 ... 6	0000010
18.16 Auto restart time-out op	Sets the operation of this protection.	Off, Stop-Manual, Stop-Automatic, Indication	Off

7

## 7.17.20 HMI failure protection

This protection senses errors in communication between the Softstarter and the HMI, while the Softstarter is in local control.

If the communication with the HMI is lost for more than approximately 600 ms this protection is on.

This protection has a special action in addition to the common types of operation:

Stop HMI control - stop the local control and change to remote control i.e digital input or Fieldbus.

**HMI failure protection has these parameters:**

Parameter	Description	Setting range	Default value
19.01 HMI failure out	Identifies the Event groups this protection is part of.	Eventgroup 0 ... 6	0000010
19.02 HMI failure op	Sets the operation of this protection.	Off, Stop-Manual, Stop-Automatic, Indication, Stop HMI control	Stop-Manual

## 7.17.21 Fieldbus failure protection

This protection senses errors in Fieldbus communication between the Softstarter and the PLC.

This protection is on when all following criteria are met

- 12.02 FB interface connector is set to FBPlug, Modbus RTU or Anybus (see chapter **7.15 Fieldbus**)
- 12.03 Fieldbus control is set to ON
- The Fieldbus communication is lost for a specified time.

For FBPlug the specified communication lost time is 300 ms.

For internal Modbus RTU and Anybus modules the specified time is configurable with 19.12 Fieldbus failure timeout. This parameter has to be set before the Anybus module is started.

This protection has a special action in addition to the common types of operation:

Switch to I/O control.

With the Change to I/O control set to enable, the control of the Softstarter automatically changes from the Fieldbus to the hard wire inputs when the Fieldbus malfunctions. When the Fieldbus starts to work again, the control is automatically switched back to the Fieldbus.

7

**Fieldbus failure protection has these parameters:**

Parameter	Description	Setting range	Default value
19.03 Fieldbus failure out	Identifies the Event groups this protection is part of.	Eventgroup 0 ... 6	0000010
19.04 Fieldbus failure op	Sets the operation of this protection.	Off, Stop-Manual, Stop-Automatic, Indication, Switch to I/O control	Stop-Manual
19.12 Fieldbus failure timeout	Sets the fieldbus failure timeout.	0.5 ... 60.0 s	0.5 s

## 7.17.22 Extension I/O failure protection

This protection senses errors in communication between the Softstarter and the Extension I/O module.

If Com3 function is set to Extension I/O and the communication to the Extension I/O is lost during the set trip time this protection is on.

**Extension I/O failure protection has these parameters:**

Parameter	Description	Setting range	Default value
19.05 Ext IO failure trip time	Sets the trip time for extension I/O failure protection.	300 ... 30000 ms	1000 ms
19.06 Ext IO failure out	Identifies the Event groups this protection is part of.	Eventgroup 0 ... 6	0000010
19.07 Ext IO failure op	Sets the operation of this protection.	Off, Stop-Manual, Stop-Automatic, Indication	Stop-Manual

### 7.17.23 IO controller protection

Profinet IO controller with an established connection is set in STOP mode.



#### **WARNING**

When fieldbus failure protection is used in combination with IO controller protection do not set 19.12 Fieldbus failure timeout to more than 3 seconds. Otherwise you might get a restart, after IO controller protection trip, before tripping on fieldbus failure.

#### **IO controller protection has these parameters:**

Parameter	Description	Setting range	Default value
19.13 IO controller stop out	Identifies the Event groups this protection is part of.	Eventgroup 0 ... 6	0000010
19.14 IO controller stop op	Sets the operation of this protection.	Off, Stop-Manual, Stop-Automatic, Indication	Off

## 7.18 Warnings

The Softstarter has a number of warning functions to signal malfunctioning or other potential risks, before asserting the protection or fault. The difference between a warning and a protection is that a warning cannot stop the Softstarter and a reset of a warning is not necessary. The warning level and all other additional information to enable the warning can be set by the user.

A warning is stored in the event list. Warnings can be Enable or Disable. There is sometimes a percentage setting were the user can set at which percentage level the warning occurs.

Set warnings to an Event group by the Out parameter. The Event group can be set for relay output to control other devices in an application.

As default, all parameters are set to the same Eventgroup.

Warnings show on the HMI, but do not change the behavior of the Softstarter.

### 7.18.1 Electronic overload warning

7

Electronic overload warning is dependent of Electronic overload protection configuration (see **7.17.1 Electronic overload protection**). The EOL level is temperature in percentage of the temperature where Electronic overload protection will trip (100% will trigger a protection). Electronic overload warning is a warning of being close to trip on Electronic overload protection.

Electronic overload warning is disabled when Electronic overload protection is disabled.

**Electronic overload warning has these parameters:**

Parameter	Description	Setting range	Default value
20.01 EOL level	Sets the EOL warning level.	40.0 ... 99.0%	90.0%
20.02 EOL out	Identifies the Event groups this warning is part of.	Eventgroup 0 ... 6	0000100
23.03 EOL warning	Enables EOL warning.	Off, On	Off

### 7.18.2 Locked rotor warning

A warning signal will be given if the current exceeds the settable warning level.

The motor is running stiff.

**Locked rotor warning is configured with the following parameters:**

Parameter	Description	Setting range	Default value
20.04 Locked rotor level	Sets the Locked rotor warning level.	0.2 ... 10.0 x $I_e$	1.2 x $I_e$
20.05 Locked rotor init time	Sets the time delay after top of ramp when the warning is enabled.	1.0 ... 30.0 s	5.0 s
20.06 Locked rotor out	Identifies the Event groups this warning is part of.	Eventgroup 0 ... 6	0000100
20.07 Locked rotor	Enables locked rotor warning.	Off, On	Off
20.10 Locked rotor trip time	Sets the time that the rotor is locked before trip.	0.1...100.0 s	0.1 s

### 7.18.3 Thyristor overload warning

The thyristor temperature is higher than 90 % of the trip level.

**Thyristor overload warning has these parameters:**

Parameter	Description	Setting range	Default value
20.08 Thyristor OL out	Identifies the Event groups this warning is part of.	Eventgroup 0 ... 6	0000100
20.09 Thyristor OL	Enables thyristor overload warning.	Off, On	Off

### 7.18.4 Current underload warning

The line current decreases below the specified value during continuous operation.

**Current underload warning has these parameters:**

Parameter	Description	Setting range	Default value
21.01 Curr underload level	Sets the Current underload warning level.	0.1 ... $1.0 \times I_e$	$0.8 \times I_e$
21.02 Curr underload trip time	Sets the time that the current is lower than the Warning level to trip.	0 ... 30 s	1 s
21.03 Curr underload delay time	Sets the time delay after Top of ramp when the warning is enabled.	0 ... 30 s	5 s
21.04 Curr underload out	Identifies the Event groups this warning is part of.	Eventgroup 0 ... 6	0000100
21.05 Curr underload	Enables Current underload warning.	Off, On	Off

7

### 7.18.5 Power factor underload warning

The power factor is below the warning level.

**Power factor underload warning has these parameters:**

Parameter	Description	Setting range	Default value
21.06 Pwr factor underload level	Sets the Power factor underload limit.	0.0 ... 1.0	0.7
21.07 Pwr factor underload trip time	The time it is below limit until trip.	0 ... 30 s	1 s
21.08 Pwr factor underload delay time	The time until diagnoser starts to work in Top of ramp.	0 ... 30 s	5 s
21.09 Pwr factor underload out	Identifies the Event groups this warning is part of.	Eventgroup 0 ... 6	0000100
21.10 Pwr factor underload	Enables Power factor underload warning.	Off, On	Off

### 7.18.6 Current imbalance warning

The phase imbalance between the currents (in %) is higher than the set value.

**Current imbalance warning has these parameters**

Parameter	Description	Setting range	Default value
21.11 Current imb level	Sets the permitted Current imbalance warning level between the phase with the highest current and the phase with the lowest current.	10 ... 80%	70%
21.12 Current imb out	Identifies the Event groups this warning is part of.	Eventgroup 0 ... 6	0000100
21.13 Current imbalance	Enables the Current imbalance warning.	Off, On	Off
21.14 Current imbalance trip time	User set time until warning in seconds.	0.1...100.0 s	5.0 s

## 7.18.7 Overvoltage warning

The voltage is higher than the set value.

**Overvoltage warning has these parameters:**

Parameter	Description	Setting range	Default value
22.01 Overvoltage level	User set warning level in Volts.	208 ... 760 V	650 V
22.02 Overvoltage trip time	User set time until warning in seconds.	0.1 ... 100.0 s	1.0 s
22.03 Overvoltage out	Identifies the Event groups this warning is part of.	Eventgroup 0 ... 6	0000100
22.04 Overvoltage	Parameter to enable Overvoltage warning.	Off, On	Off

## 7.18.8 Undervoltage warning

The main voltage is lower than the set warning level.

**Undervoltage warning has these parameters:**

Parameter	Description	Setting range	Default value
22.05 Undervoltage level	User set warning level in Volts.	208 ... 850 V	208 V
22.06 Undervoltage trip time	User set time until warning in seconds.	0.1 ... 100.0 s	0.5 s
22.07 Undervoltage out	Identifies the Event groups this warning is part of.	Eventgroup 0 ... 6	0000100
22.08 Undervoltage	Parameter to enable Undervoltage warning.	Off, on	Off

7

## 7.18.9 Voltage imbalance warning

The voltage imbalance between the phases is higher than the set warning level.

**Voltage imbalance warning has these parameters:**

Parameter	Description	Setting range	Default value
22.09 Voltage imb level	Sets the permitted Voltage imbalance level between the phase with the highest voltage and the phase with the lowest voltage.	1 ... 10 %	5 %
22.10 Voltage imb out	Identifies the Event groups this warning is part of.	Eventgroup 0 .. 6	0000100
22.11 Voltage imbalance	Enables Voltage imbalance warning.	Off, On	Off
22.12 Voltage imbalance trip time	User set time until warning in seconds.	0.1...100.0 s	5.0 s

## 7.18.10 Electronic overload time-to-trip warning

The predicted time before EOL trip is below the set warning level. The predicted time to trip assumes that the current stays on existing level.

**Electronic overload time-to-trip warning has these parameters:**

Parameter	Description	Setting range	Default value
23.01 EOL time-to-trip time	Sets how long time before the EOL protection trips the warning is on.	1 ... 1000 s	5 s
23.02 EOL time-to-trip out	Identifies the Event groups this warning is part of.	Eventgroup 0 ... 6	0000100
23.03 EOL time-to-trip	Enables EOL time to trip warning.	Off, On	Off

## 7.18.11 Total Harmonic Distortion warning

The actual power system voltage differs from the ideal sine wave. Total Harmonic Distortion (THD) is higher than the warning level.

**Total Harmonic distortion warning has these parameters:**

Parameter	Description	Setting range	Default value
23.04 THD(U) level	Sets the warning level for Total Harmonic Distortion (U).	1 ... 10%	10%
23.05 THD(U) out	Identifies the Event groups this warning is part of.	Eventgroup 0 ... 6	0000100
23.06 THD(U)	Enables Total Harmonic Distortion warning.	Off, On	Off
23.09 THD(U) trip time	User set time until warning in seconds.	0.1 ... 100.0 s	10.0 s

7

## 7.18.12 Short circuit warning

There is an internal short circuit and limp mode is enabled. If limp mode is off, this is a short circuit fault instead. Speak to ABB Sales Offices for service.

**Short circuit warning has these parameters:**

Parameter	Description	Setting range	Default value
23.07 Short circuit out	Identifies the Event groups this warning is part of.	Eventgroup 0 ... 6	0000100
23.08 Short circuit	Enables Short circuit warning.	Off, On	On

## 7.18.13 Number of starts warning

User configurable limit of Number of starts (resettable). When the Number of starts exceeds the limit a warning will be generated.

**Number of starts warning has these parameters:**

Parameter	Description	Setting range	Default value
24.01 Number of starts limit	Max number of starts	1 ... 65535	65535
24.02 Number of starts out	Specifies the Event groups this warning belongs to.	Eventgroup 0 ... 6	0000100
24.03 Number of starts	Enables Number of starts warning	Off, On	Off

## 7.18.14 Phase loss warning

Phase loss warning.

**Phase loss warning has these parameters:**

Parameter	Description	Setting range	Default value
24.07 Phase loss trip time	Trip time in seconds	0.5 ... 100.0 s	3.0 s
24.08 Phase loss out	Specifies the Event groups this warning belongs to.	Eventgroup 0 ... 6	0000100
24.09 Phase loss	Enables Phase loss warning	Off, On	Off

## 7.18.15 Motor runtime warning

User configurable limit of Motor run time (resettable).

When the Motor run time exceeds the limit a warning will be generated.

**Motor runtime warning has these parameters:**

Parameter	Description	Setting range	Default value
24.10 Motor runtime limit	Max runtime in hours	1 ... 100 000 h	10 000 h
24.11 Motor runtime out	Specifies the Event groups this warning belongs to.	Eventgroup 0 ... 6	0000100
24.12 Motor runtime	Enables Motor runtime warning	Off, On	Off

7

## 7.18.16 Parameter storage warning

Parameters could not be stored. Will not impact current run cycle, but a power cycle may restore default settings. Contact ABB sales office for service.

**Parameter storage warning has these parameters:**

Parameter	Description	Setting range	Default value
24.13 Storage warning out	Specifies the Event groups this warning belongs to.	Eventgroup 0 ... 6	0000100
24.14 Storage warning	Enables Parameter storage warning	Off, On	Off



## 7.19 Faults

The Softstarter has a number of fault detection functions to protect the Softstarter. Faults detection always runs as default. The user cannot set the fault detection to off. If a signal malfunctions in the Softstarter, the motor or in the power network level, a fault occurs. Supervised faults can be internal or external faults.

### Internal fault:

The Softstarter has a fault. see chapter **10 Troubleshooting**, and speak to ABB sales office if necessary.

### External fault:

There is a fault in the equipment that is connected to the Softstarter. see chapter **10 Troubleshooting**, and speak to ABB sales office if necessary.

When a fault occur, the type of fault will be described on the home screen and the red Fault LED light will illuminate.

When a fault occurs, the unit does these basic actions:

1. The fault LED illuminates
2. The home screen gives the type of fault
3. The type of event is stored on the event list
4. The power supply to the motor which is connected to the Softstarter is set to off (Direct stop).

You can set faults to have automatic reset or manual reset. Every fault has a parameter option called **Operation**, that you can set as:

- **Stop-Automatic** – The engine stops and resets automatically after you correct the fault condition\*.
- **Stop-Manual** – The engine stops and must be reset manually after you correct the fault condition\*.
- **Indication** – Emergency mode only, see chapter **7.20.1 Emergency mode**.

\*) You cannot reset a fault before you correct the fault condition.

You can set faults to an Event group by a parameter option called Out. You can set the Event group for relay output to control other devices in an application.

As default all parameters are set to the same Eventgroup.

You can add further actions for each fault, or change the basic actions. If multiple faults occur they are all stored in a sequence. Do a reset for each fault if manual reset is selected.

## 7.19.1 Internal faults

### 7.19.1.1 Shunt fault

The Softstarter has been shorted and cannot stop the power to the motor.

If Softstarter is connected in-line, shunt fault is on if 2 or 3 phases are shorted.

If Softstarter is connected inside-delta, shunt fault is on if 1 or more phases are shorted.

If the user puts shunt fault on 1 relay and connect it to a line contactor or a circuit breaker, the user can break off the motor.

Shunt fault trip time is set with parameter 28.49.

Shunt fault trip level is set with parameter 28.50.

Speak to ABB sales office for service.

#### Shunt fault has these parameters:

Parameter	Description	Setting range	Default value
25.01 Shunt fault out	Identifies the Event groups this fault is part of.	Eventgroup 0 ... 6	0000001
25.02 Shunt fault op	Sets the operation of this fault.	Stop-Manual, Stop Automatic	Stop-Manual

## 7

### 7.19.1.2 Short circuit fault

The Softstarter has a short circuit thyristor or bypass. The Softstarter can run in Limp mode function, even if 1 phase become shorted.



#### INFORMATION

If Automatic restart is set to on, a short circuit fault will automatically start the motor again.

For more information about Automatic restart, see **chapter 7.13 Automatic restart**.

If 1 or multiple thyristors are shorted, speak to ABB sales office for service.

Short circuit thyristor trip time is 1s.

#### Short circuit fault has these parameters:

Parameter	Description	Setting range	Default value
25.03 Short circuit out	Identifies the Event groups this fault is part of.	Eventgroup 0 ... 6	0000001
25.04 Short circuit fault op	Sets the operation of this fault.	Stop-Manual, Stop Automatic	Stop-Manual

### 7.19.1.3 Open circuit thyristor fault

The Softstarter cannot close 1 or more thyristors.  
There will be a trip on open circuit thyristor after 100 consecutive failed attempts to trigger the thyristor.



#### INFORMATION

If Automatic restart is set to on, an open circuit thyristor fault will automatically start the motor again.

For more information about Automatic restart see chapter **7.13 Automatic restart.**

**Open circuit thyristor fault has these parameters:**

Parameter	Description	Setting range	Default value
25.05 Open circuit thyr out	Identifies the Event groups this fault is part of.	Eventgroup 0 ... 6	0000001
25.06 Open circuit thyr op	Sets the operation of this fault.	Stop-Manual, Stop Automatic	Stop-Manual

### 7.19.1.4 Thyristor overload fault

The thyristors in the Softstarter are overloaded.  
If the estimated thyristor junction temperature is higher than the maximum permitted value, this fault is signaled, to protect thyristors from overheating.



#### INFORMATION

If Automatic restart is set to on, a thyristor overload fault will automatically start the motor again.

For more information about Automatic restart see chapter **7.13 Automatic restart.**

**Thyristor overload fault has these parameters:**

Parameter	Description	Setting range	Default value
25.07 Thyristor OL out	Identifies the Event groups this fault is part of.	Eventgroup 0 ... 6	0000001
25.08 Thyristor OL op	Sets the operation of this fault.	Stop-Manual, Stop Automatic	Stop-Manual

### 7.19.1.5 Heatsink overtemperature fault

The Softstarter measures the heatsink temperature. If the temperature gets to high this fault is signaled. The purpose of the heatsink is to keep the thyristors cool.

For a trip to occur, the heat sink temperature has to be greater than 105 degrees for more than 1 s.

**Heatsink overtemperature fault has these parameters:**

Parameter	Description	Setting range	Default value
25.09 Heatsink overtemp out	Identifies the Event groups this fault is part of.	Eventgroup 0 ... 6	0000001
25.10 Heatsink overtemp op	Sets the operation of this fault.	Stop-Manual, Stop Automatic	Stop-Manual

### 7.19.1.6 Unspecified fault

#### Unspecified fault has these parameters:

Parameter	Description	Setting range	Default value
25.11 Unspecified fault out	Identifies the Event groups this fault is part of.	Eventgroup 0 ... 6	0000001
25.12 Unspecified fault op	Set the operation of this fault.	Stop-Manual, Stop Automatic	Stop-Manual

### 7.19.1.7 Electronics failure

Circuit fault detected during hardware initialization.

#### Electronics failure has these parameters:

Parameter	Description	Setting range	Default value
25.13 Electronics failure out	Identifies the Event groups this fault is part of.	Eventgroup 0 ... 6	0000001
25.14 Electronics failure op	Set the operation of this fault.	Stop-Manual, Stop Automatic	Stop-Manual

## 7

### 7.19.2 External faults

#### 7.19.2.1 Phase loss fault

Voltage to one or more phases are missing.

When motor is not running, the trip time is equal to 5 s.

When motor is running the trip time is equal to 500 ms.

#### Phase loss fault has these parameters:

Parameter	Description	Setting range	Default value
26.01 Phase loss out	Identifies the Event groups this fault is part of.	Eventgroup 0 ... 6	0000001
26.02 Phase loss op	Set the operation of this fault.	Stop-Manual, Stop Automatic	Stop-Manual

#### 7.19.2.2 Bad network fault

Bad network quality fault is signaled if there is too much frequency interference in the network. During these conditions the softstarter will experience issues with the thyristor control algorithm, and for safety reasons, the softstarter will not continue to operate until the conditions are resolved.

For this trip to occur, the bad network quality conditions have to be present for more than 1 s.

#### Bad network fault has these parameters:

Parameter	Description	Setting range	Default value
26.03 Bad network out	Identifies the Event groups this fault is part of.	Eventgroup 0 ... 6	0000001
26.04 Bad network op	Set the operation of this fault.	Stop-Manual, Stop Automatic	Stop-Manual

### 7.19.2.3 Low supply voltage fault

Low supply voltage fault is signaled if the control supply voltage is too low. The Softstarter will stop the motor.

There will be a trip on low supply voltage as soon the internal 24 VDC supply voltage dips below 19 V.

**Low supply fault has these parameters:**

Parameter	Description	Setting range	Default value
26.05 Low supply voltage out	Identifies the Event groups this fault is part of.	Eventgroup 0 ... 6	0000001
26.06 Low supply voltage op	Sets the operation of this fault.	Stop-Manual, Stop Automatic	Stop-Manual

### 7.19.2.4 High current fault

A fault signal will be given if the motor current exceeds the fixed set level which is  $8 \cdot I_r$  for the duration of the fixed set time which is 200 ms.

**High current fault is configured with the following parameters:**

Parameter	Description	Setting range	Default value
26.07 High current out	Specifies the Event groups this fault belongs to.	Eventgroup 0 ... 6	0000001
26.08 High current op	Sets the operation of this fault.	Stop-Manual, Stop Automatic	Stop-Manual

### 7.19.2.5 Faulty usage fault

Faulty usage fault is on if the user tries to use motor heating, stand-still brake and slow speed functions when the motor is connected inside delta or if the user tries to use demo mode when mains three phase voltage is connected.

There will be a trip as soon as faulty usage is detected.

**Faulty usage fault has these parameters:**

Parameter	Description	Setting range	Default value
26.09 Faulty usage out	Identifies the Event groups this fault is part of.	Eventgroup 0 ... 6	0000001
26.10 Faulty usage op	Sets the operation of this fault.	Stop-Manual, Stop Automatic	Stop-Manual

### 7.19.2.6 Connection fault

Connection fault signals a fault when a faulty connection is detected for each type of connection, in line and inside delta.

Trip time is 5 s.

**Connection fault has these parameters:**

Parameter	Description	Setting range	Default value
26.11 Faulty connection out	Identifies the Event groups this fault is part of.	Eventgroup 0 ... 6	0000001
26.12 Faulty connection op	Sets the operation of this fault.	Stop-Manual, Stop Automatic	Stop-Manual

## 7.20 Special feature

This chapter gives a description of features that are available to all users, but beyond the normal range of use for the Softstarter.

The features are:

- Emergency mode
- Line contactor close time
- Limp mode
- Start without start command
- Step down level
- System mode
- TOR relay delay time
- Voltage sag detection

### 7.20.1 Emergency mode

The normal operation of the Softstarter when a fault is detected is to do a direct stop. The programmable digital input can be set to Emergency mode (active low) or Emergency mode (active high), see chapter 7.14.2 Digital Inputs When Emergency mode is active, a symbol in the upper right corner of the HMI screen will be visible, see chapter 6.1.5 Symbols in the screen

When the Softstarter is in Emergency mode, and a fault or protection is detected, the Softstarter will try to run the motor with the start and stop signals, ignore safety and continue to run regardless of consequences. This can be done as long as the PCBA is not broken.

The programmable output relays can be programmed to Event group 0...6 but will not be activated to an event during Emergency mode. This is important in the case the output relays is used to control a line contactor or circuit breaker All events will be stored in the event log.

- If the build-in bypass is not working the circuit to the motor is closed by using the thyristors
- If the thyristors are not working the circuit to the motor is closed by using the built-in bypass.



---

#### **WARNING**

Warranty for damage on the thyristors or the built-in bypass are not valid during Emergency mode.

---

## 7.20.2 Line contactor close time

This feature allow time for the line contactor to close before the Softstarter assumes that it has correct 3 phase supply.

This is useful to avoid timing problems that can lead to unnecessary trips on for example Phase loss protection.

### Line contactor close time has these parameters:

Parameter	Description	Setting range	Default value
28.02 Line contactor close time	Allow time for line contactor to close. Sets the time between start signal and beginning of diagnostic measurements.	0 ... 65535 ms	250 ms

## 7.20.3 Limp mode

This feature allows the PSTX to operate with only 2 controlled phases in case of short circuit of 1 set of thyristors. When PSTX trips for fault "Short circuit thyristor" and error code F0900 the customer can check with external equipment which phase is shorted. Always verify the fault by measuring the phase.

If error code is: F0901 - L1 is shorted, F0902 - L2 is shorted, F0903 - L3 is shorted. Set parameter Limp mode and Motor connection as described. The fault will be replaced with a warning to enable start in limp mode. Replace the thyristors when this warning is on (if the short circuit warning is enabled).

### Limp mode has these parameters:

Parameter	Description	Setting range	Default value
28.42 Limp mode	Set to On if a phase is shorted.	Off, On	Off
28.43 Motor connection	When Limp mode is On, set depending on which phase that is shorted, Two phase (Lx shorted)	Inline, Inside delta UI, Inside delta IU, Two phase (L1 shorted), Two phase (L2 shorted), Two phase (L3 shorted)	-

## 7.20.4 Start without start command

This feature can be used for a customer that would like to use the Softstarter in the same way as a contactor is used, i.e. as soon as the control supply to the Softstarter is turned on the Softstarter will automatically start the motor. No wiring of start and stop signals is necessary.

### Start without start command has these parameters:

Parameter	Description	Setting range	Default value
28.04 Start without start command	Starts the motor without needing an external start command.	Off, On	Off

## 7.20.5 Step down level

When the Softstarter receives a stop signal the Softstarter first decreases the output voltage to the motor in a quick stop ramp, from full voltage down to set Step down voltage level. Then the Softstarter controls the output voltage in a stop ramp.

You can adjust the step down level for torque control.

When using voltage ramp, set it to 80%. It can be necessary to adjust the step down level if the load is too high or too low.

**Step down level has these parameters:**

Parameter	Description	Setting range	Default value
28.05 Step down level	Set the level from where the stop ramp initiates.	10% ... 100%	80%

## 7.20.6 System mode

Select between:

- Normal mode
- Demo mode
- Small motor mode

### Normal mode

Normal mode is the default setting and is used in all situations except the ones given below.

### Demo mode

Demo is used mainly for training purposes to simulate a load condition without having the Softstarter connected to main power.



### INFORMATION

When the Softstarter is connected to three phase voltage it will not be possible to start a motor in demo mode.

### Small motor mode

Small motor mode is used for basic testing purposes, when using a smaller motor than the PSTX is specified for. The Softstarter is able to start the motor, but some functions and protections are disabled.



### INFORMATION

The current through the Softstarter has to be at least 3A when using small motor mode.

**System mode has these parameters:**

Parameter	Description	Setting range	Default value
28.41 System mode	Sets the run mode.	Normal, Demo, small motor	Normal



## 7.20.7 TOR relay delay time

Set the delay time from Top Of Ramp until the Top Of Ramp relay is on

**TOR relay delay time has these parameters:**

Parameter	Description	Setting range	Default value
28.03 TOR relay delay time	Set the delay time from Top Of Ramp until the Top Of Ramp relay is on	0.0 ... 300.0 s	0.0 s

## 7.20.8 Voltage sag detection

This function makes it possible to monitor the quality of the mains voltage.

A voltage dip under 65% of nominal voltage for more than 200 ms combined with a fault or protection generates a Voltage sag detection-event in the Run log. This event indicates that the original fault or protection was triggered by a voltage sag.

A voltage dip under 65% of nominal voltage for more than 200 ms and immediately followed by increase up to 90% of nominal voltage also generates a Voltage sag detection-event in the Run log. Common reoccurrence of such events can indicate poor quality of mains voltage.

## 7.21 Pump cleaning

Pump cleaning function makes the pump motor alternate between forward and reverse direction. This sequence can release or cut through solid objects and flush away effluent.

The pump cleaning function can be used to solve these two problems which are common especially in waste water plants.

- **Jamming:** Occurs when a semi large solid object like a piece of plastic or wood gets stuck in the pump blades.
- **Clogging:** When the liquid that is being pumped contains small particles and effluent, the risk is that this material will over time get permanently attached within the pipes and cause water flow problems which will decrease the pump efficiency and can damage the pump.

Solving these problems will result in an overall improved pump efficiency, reduced down time and low maintenance costs.

To detect when a pump is jammed or clogged, it's recommended to use one of the following methods.

- When an object is stuck in the pump, the motor uses more current and the Softstarter will trip on EOL (Electronic overload), see chapter **7.17.1 Electronic overload protection** or Locked rotor protection, see chapter **7.17.2 Locked rotor protection**.
- During a soft start the Too long starting time, see chapter **7.17.18 Too long start time protection**, or Too long time at current limit, see chapter **7.17.17 Too long current limit protection**, can be used to indicate that an object is stuck in the pump.
- A water flow sensor can be used to detect if the pipes are clogged. The sensor output can be connected to one of the PSTX programmable inputs and configure it as user defined protection, see chapter **7.17.15 User defined protection**

7



### INFORMATION

The Softstarter cannot automatically start the pump cleaning sequence when the fault events mentioned above occur. External logic have to be used to give the pump cleaning commands if and when the protection events occur.

Pump cleaning can also be used as preventive maintenance by running the function once a day/week.

## 7.21.1 Manual pump cleaning

Manual means that the user at any point in time decides which direction the motor shall rotate by activating the forward and reverse pump cleaning commands. The commands can be given in the HMI, or using hardware I/O's or the fieldbus. The same parameters that are used for Automatic pump cleaning are also used for Manual pump cleaning, see chapter **7.21.2 Automatic pump cleaning**

## 7.21.2 Automatic pump cleaning

Automatic means that the Softstarter runs the pump cleaning sequence only when the automatic pump cleaning command is activated and stops as soon as it is deactivated. When automatic pump cleaning is run, the motor first starts rotating in the backward direction.

Different motor control functions are combined to achieve the forward and reverse run of the motor.

1. Slow speed jog reverse. Parameter 29.01 (Pump clean reverse speed) decides which slow speed should be used. The parameter 29.02 (Pump clean reverse strength) decides how fast the motor accelerates to the slow speed in the reverse direction. It is recommended to set it to a high value (60 – 100%) to achieve an aggressive acceleration for clogging or enough torque for jamming.
2. Forward direction. Parameter 29.03 (Pump clean forward start mode) decides which start method should be used to accelerate the motor in the forward direction. Default is Full voltage start which very quickly accelerated the motor up to full speed in the forward direction. If a softer start is needed parameter 29.03 (Pump clean forward start mode) can be set to Torque ramp or Voltage ramp, then the parameter 02.03 (Start ramp initial level) and 02.04 (Start ramp time) are used in the pump cleaning forward start. 29.04 (Pump clean auto forward time) decides how long time the motor should be run in the forward direction.
3. When it is time to switch direction from forward to reverse the parameter 29.08 (Pump clean stop mode) decides if a stop ramp should be run to avoid any water hammering that might otherwise occur. Immediately after the stop ramp a dynamic brake quickly bring the motor to stand still. Parameter 29.08 (Pump clean stop mode) is set default to Torque ramp and brake. The Torque ramp or Voltage ramp in the Pump clean stop mode can be adjusted by parameter 02.05 (Stop ramp end level) and parameter 02.06 (Stop ramp time). The Dynamic brake in the Pump clean stop mode can be adjusted by the parameter 29.06 (Pump clean brake strength) and parameter 29.07 (Pump clean brake timeout). The parameter 29.06 (Pump clean brake strength) decides how fast the motor will decelerate from full speed. It is recommended to set a high value (50 – 60%) to achieve an aggressive deceleration. If the brake takes longer time than 10s, increase the parameter 29.07 (Pump clean brake timeout).

4. The whole sequence is repeated and start from 1 again until the Auto button on the HMI is released or signal from I/O or fieldbus is removed.

See **Figure 7.9** .

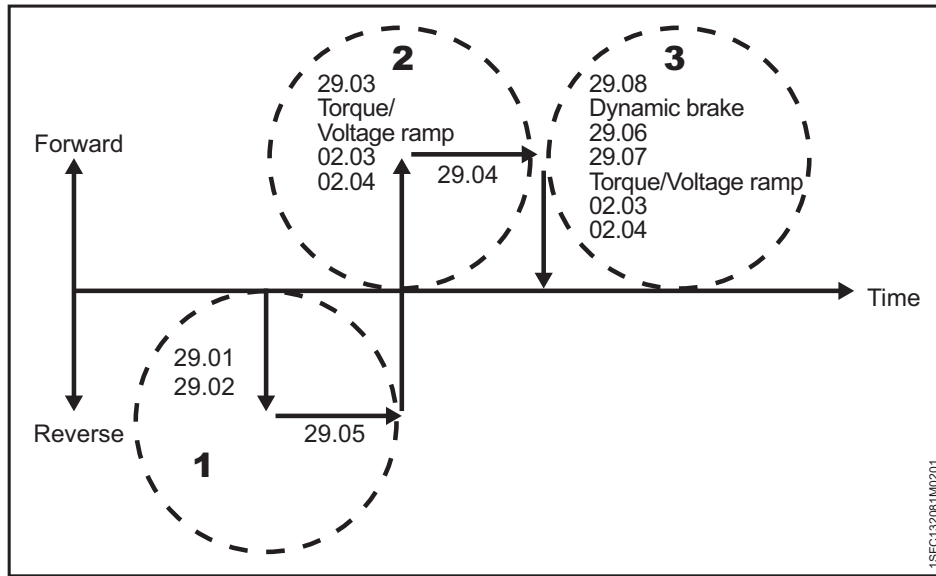


Figure 7.9

Automatic pump sequence

7

**Water hammering**

If water hammering is not a problem parameter 29.08 (Pump clean stop mode) can be set to Dynamic brake which will ensure a quicker deceleration and therefore better pump cleaning performance. The Dynamic brake can be adjusted by the parameter 29.06 (Pump clean brake strength) and parameter 29.07 (Pump clean brake timeout).

However if water hammering, which can damage the pipes, is a problem the parameter 29.08 (Pump clean stop mode) can be set to Voltage ramp and brake or Torque ramp and brake. The parameter 02.05 (Stop ramp end level) and parameter 02.06 (Stop ramp time) are also used in the Voltage ramp and Torque ramp.

### 7.21.3 Pump cleaning control

Operate this function through the HMI, I/O or Fieldbus.




#### HMI

Pump cleaning menu, see **Figure 7.10**.

Control the pump cleaning menu, see **Figure 7.11**

**Path in menu:**

**Menu > Pump cleaning**

- Press left button  for manual backward pump cleaning
- Press right button  for manual forward pump cleaning
- Press up button  for automatic pump cleaning

#### Hardware I/O

**Path in menu: Menu > Parameters > Complete list > 10 Internal In0, In1, In2 / 11 External IO 1DI0, 1DI1, 1DI2, 1DI3, 1DI4, 2DI5, 2DI6, 2DI7**

Configure the parameters to either Pump cleaning automatic, Pump cleaning forward or Pump cleaning backward.



#### INFORMATION

An Extension I/O module, see chapter 5.1.3 Extension I/O, is necessary if the **11 External IO** is going to be used.

#### Fieldbus configuration

Fieldbus digital outputs (from PLC to Softstarter) can be used to run Pump cleaning automatic, Pump cleaning forward or Pump cleaning backward.

For more information about the communication, see chapter **8 Communication**

**Pump cleaning is configured with the following parameters:**

Parameter	Description	Setting range	Default value
29.01 Pump clean reverse speed	Sets the slow speed reverse. Fast jog reverse is 33 %, jog reverse is 20 % and creep reverse is 9 % of the nominal motor speed.	Fast jog, Jog, Creep	Jog
29.02 Pump clean reverse strength	Parameter related to the torque that is generated during slow speed in the reverse direction. Choose suitable value for the application. Too high value could cause oscillations and if too low the motor may not start.	10 ... 100 %	45 %
29.03 Pump clean forward start mode	Sets the desired start mode: Voltage start ramp = Increases voltage linearly, Torque start ramp = Increases torque in a pre-defined pattern, Full Voltage start = Ramps up to full voltage within one third of a second	Voltage ramp, Torque ramp, Full voltage start	Full voltage start
29.04 Pump clean auto forward time	Sets the number of seconds to run forward per sequence for automatic pump cleaning.	1.0 ... 100.0 s	5.0 s
29.05 Pump clean auto reverse time	Sets the number of seconds to run reverse per sequence for automatic pump cleaning.	1.0 ... 100.0 s	5.0 s
29.06 Pump clean brake strength	Sets the pump cleaning braking strength to 10-100 %. Only used for pump cleaning in forward direction.	10 ... 100 %	45 %
29.07 Pump clean brake timeout	Sets the motor brake timeout used when pump cleaning forward has finished.	1.0 ... 100.0 s	10.0 s
29.08 Pump clean stop mode	Sets the mode for stop used when pump cleaning forward has finished: Stop ramp followed by dynamic brake, or dynamic brake only. See chapter <b>7.2.2 Voltage stop ramp</b> and <b>7.3.2 Torque stop ramp</b> for stop ramp parameters. See chapter <b>7.11 Motor braking</b> for speed threshold and delay time.	Voltage ramp and brake, Torque ramp and brake, Dynamic brake	Torque ramp and brake

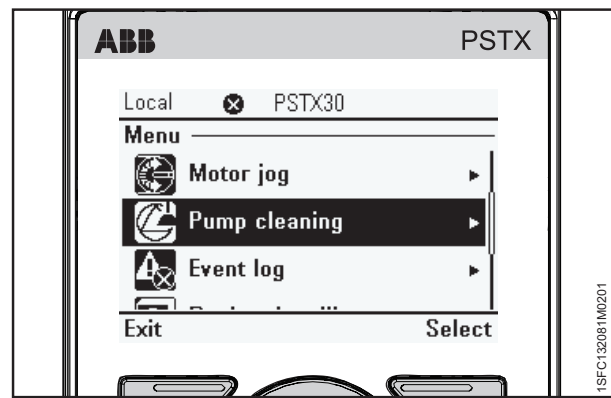


Figure 7.10

Pump cleaning menu

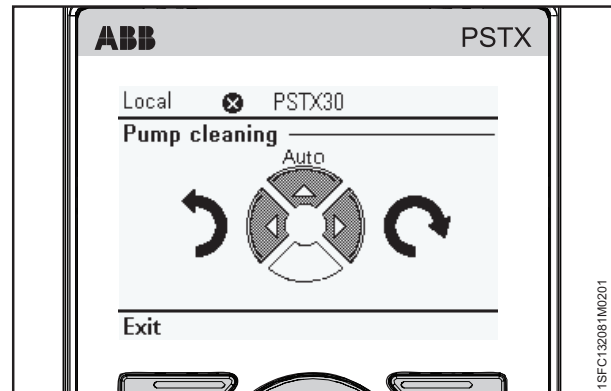


Figure 7.11

Control the pump cleaning menu



---

**INFORMATION**

If many pump cleaning cycles are used and run often, it is recommended to use a one size larger Softstarter.

---

**WARNING**

Pump cleaning is only working when the Softstarter is connected in-line

---

**WARNING**

Because the Pump clean reverse function warms up the motor we recommend to use a PTC or PT100 element for temperature monitoring. In some conditions, the built-in EOL is not accurate for this feature.

---

**WARNING**

Do not use pump cleaning on pumps which have impeller or rotating shaft parts which can loosen or jam during reverse rotation. If you do not obey these instructions, this can cause equipment damage.

---

## 7.22 Fast take-off

The PSTX is equipped with a fast take-off functionality. This means that by delaying some non-critical functions, the time from the start signal is given until the voltage is applied to the motor is reduced. The Fast take-off enables motor voltage after approximate 600 ms from received start signal, which is approximate 500 ms faster than the regular operation of 1100 ms .

To reduce this time even more the parameter 28.02 Line contactor close time can be set to 0, default is 250 ms, see chapter 7.20.2. Then the time for received start to voltage is applied will approximately be 350 ms and the regular operation time will approximately be 850 ms.

The parameter 28.43 Motor connection is default Auto this can be set to the actual motor connection then the time for received start to voltage will be decreased by approximately 100 ms.

**Note:** Torque control- and dynamic brake performance might be affected in a minor way in specific situations.

## 7.23 Settings

The settings menu contains these Softstarter set-up parameters:

- Language
- Date and time
- Display settings (for HMI)
- Reset from defaults

For settings and navigation, **see chapter 6.4.6 Settings.**

## 7.24 Assistants

The Assistants menu contains default settings and parameters. Use this menu to set only the necessary parameters before you can start the motor. All necessary input data shows up in an automatic loop. The Assistants menu is divided in:

- **Basic set-up**
- **Application set-up**



---

### INFORMATION

After you select an application and make your changes, do not select this application again because this resets the application to the default settings.

---

### Enter the Assistants menu

Push “Menu” and select Assistants with the Navigation keys.

Push “Select” to enter the Assistants menu.

### Basic set-up

The Basic set-up menu is divided in 5 steps: Language, Date and time, Motor data and System configuration.

### Application set-up

The Application set-up are quick settings for Applications, Values and Tune settings. Use the Navigation keys to select Application set-up. Push “Select” to enter the Application set-up.

Select for what type of application you use the Softstarter by pushing “Select”.

For more details, see chapter **2 Quick start.**

## 7.24.1 Table Application settings

	Recommended basic settingsg							
	Start ramp time	Stop ramp time	Start ramp initial level	Stop ramp end level	Current limit level	Start mode	Stop mode	
Normal start (class 10)	Band saw	10	-	30	30	4	Voltage ramp	No ramp
	Bow thruster	10	-	30	30	3	Voltage ramp	No ramp
	Centrifugal pump	10	10	30	30	4	Voltage ramp	Torque ramp
	Circular saw	10	-	30	30	4	Voltage ramp	No ramp
	Conveyor belt short	10	-	40	30	3,5	Voltage ramp	No ramp
	Cutter	10	-	30	30	4	Voltage ramp	No ramp
	Escalator	10	-	30	30	3,5	Voltage ramp	No ramp
	High pressure pump	10	10	40	30	4,5	Voltage ramp	Torque ramp
	Hydraulic pump	10	-	30	30	3	Voltage ramp	No ramp
	Lift/Elevator	10	-	30	30	3,5	Voltage ramp	No ramp
	Piston compressor	5	-	50	30	3	Voltage ramp	No ramp
	Scroll compressor	2	-	50	30	3	Voltage ramp	No ramp
Heavy duty start (class 30)	Axial fan	10	-	30	30	4	Voltage ramp	No ramp
	Conveyor belt long	10	-	40	30	3,5	Voltage ramp	No ramp
	Crusher	10	-	30	30	4	Voltage ramp	No ramp
	Centrifugal fan	10	-	30	30	4	Voltage ramp	No ramp
	Grinder	10	-	30	30	4	Voltage ramp	No ramp
	Mixer	10	-	30	30	3,5	Voltage ramp	No ramp

Note: These parameter are a rough indication. Often it is necessary to tune the unit because of variations in load conditions.



## 7.25 Complete parameter list

Parameter number	Description	Setting range	Number of decimals	Fieldbus ID	Default value	Actual setting
<b>01</b>	<b>Motor rated current I<sub>e</sub></b>					
01.01	Motor rated current I <sub>e</sub>	9.0 ... 1250.0 A	1	1	30 A	
<b>02</b>	<b>Start and stop</b>					
02.01	Start mode	Voltage ramp, Torque ramp, Full voltage start	0	2	Voltage ramp	
02.02	Stop mode	No ramp, Voltage ramp, Torque ramp, Dynamic brake	0	3	No ramp	
02.03	Start ramp initial level	10 ... 99%	0	4	30%	
02.04	Start ramp time	1 ... 120 s	0	5	10 s	
02.05	Stop ramp end level	10 ... 99%	0	6	30%	
02.06	Stop ramp time	1 ... 120 s	0	7	10 s	
02.07	Pre-start function	Pre start off, Motor heating, Stand still brake Slow speed forward, Slow speed reverse	0	93	Pre start off	
02.08	Pre-start time	0.0 ... 7200.0 s	1	128	10.0 s	
<b>03</b>	<b>Limit</b>					
03.01	Current limit type	Off, Normal, Dual, Ramp	0	18	Normal	
03.02	Current limit level	1.5 ... 7.5 x I <sub>e</sub>	1	19	4.0 x I <sub>e</sub>	
03.03	2nd curr lim level	0.5 ... 7.5 x I <sub>e</sub>	1	20	7.0 x I <sub>e</sub>	
03.04	2nd curr lim time	2 ... 120 s	0	21	8 s	
03.05	Torque limit level	20 ... 200%	0	170	150%	
<b>04</b>	<b>Kick start</b>					
04.01	Kick start	On / Off	0	22	Off	
04.02	Kick start level	50 ... 100%	0	23	70%	
04.03	Kick start time	0.20 ... 2.00 s	2	24	0.20 s	
<b>05</b>	<b>Slow speed</b>					
05.01	Slow speed forward	Fast jog, Jog, Creep	0	184	Jog	
05.02	Slow speed fwd strength	10 ... 100%	0	187	50%	
05.03	Slow speed reverse	Fast jog, Jog, Creep	0	188	Jog	
05.04	Slow speed rev strength	10 ... 100%	0	189	50%	
<b>06</b>	<b>Motor heating</b>					
06.01	Motor heating capacity	10 ... 100000 W	0	304	10 W	
<b>07</b>	<b>Motor braking</b>					
07.01	Stand still brake strength	10 ... 100%	0	305	50%	
07.02	Motor brake time	1.0 ... 900.0 s	1		1.0 s	
07.03	Dynamic brake strength	10 ... 100%	0		40%	
07.04	DC brake strength	10 ... 100%	0		40%	
07.05	DC brake switch speed threshold	10 ... 100%	0		28%	
07.06	DC brake switch delay time	0.1 ... 100.0 s	1		3.0 s	
<b>08</b>	<b>Sequence start</b>					
08.01	Sequence mode	Off, Start several motors	0	8	Off	
08.02	I <sub>e</sub> seq 1	9.0 ... 1250.0 A	1	190	30 A	
08.03	Start mode seq 1	Voltage ramp, Torque ramp, Full voltage start	0	191	Voltage ramp	
08.04	Start ramp time seq 1	1 ... 120 s	0	192	10 s	
08.05	Start ramp init lvl seq 1	10 ... 99%	0	193	30%	
08.06	Curr lim level seq 1	0.5 ... 7.5 x I <sub>e</sub>	1	194	7.0 x I <sub>e</sub>	
08.07	Kick start seq 1	On, Off	0	195	Off	
08.08	Kick start level seq 1	50 ... 100%	0	196	70%	
08.09	Kick start time seq 1	0.20 ... 2.0 s	2	197	0.20 s	
08.10	Torque lim lvl seq 1	20 ... 200%	0	198	150%	
08.11	Torque tune seq 1	0 ... 1000%	0	199	100%	
08.12	Torque ctrl gain seq 1	0.01 ... 10.00	2	200	0.02	
08.30	I <sub>e</sub> seq 2	9.0 ... 1250.0 A	1	201	30 A	
08.31	Start mode seq 2	Voltage ramp, Torque ramp, Full voltage start	0	202	Voltage ramp	
08.32	Start ramp time seq 2	1 ... 120 s	0	203	10 s	
08.33	Start ramp init lvl seq 2	10 ... 99%	0	204	30%	

Parameter number	Description	Setting range	Number of decimals	Fieldbus ID	Default value	Actual setting
08.34	Curr lim level seq 2	0.5 ... 7.5 x I <sub>e</sub>	1	205	7.0 x I <sub>e</sub>	
08.35	Kick start seq 2	On / Off	0	206	Off	
08.36	Kick start level seq 2	50 ... 100%	0	207	70%	
08.37	Kick start time seq 2	0.20 ... 2.00 s	2	208	0.20 s	
08.39	Torque tune seq 2	0 ... 1000%	0	210	100%	
08.40	Torque ctrl gain seq 2	0.01 ... 10.00	2	211	0.02	
08.60	I <sub>e</sub> seq 3	9.0 ... 1250 A	1	212	30 A	
08.61	Start mode seq 3	Voltage ramp, Torque ramp, Full voltage start	0	213	Voltage ramp	
08.62	Start ramp time seq 3	1 ... 120 s	0	214	10 s	
08.63	Start ramp init lvl seq 3	10 ... 99%	0	215	30%	
08.64	Curr lim level seq 3	0.5 ... 7.5 x I <sub>e</sub>	1	216	7.0 x I <sub>e</sub>	
08.65	Kick start seq 3	On, Off	0	217	Off	
08.66	Kick start level seq 3	50 ... 100%	0	218	70%	
08.67	Kick start time seq 3	0.20 ... 2.00 s	2	219	0.20 s	
08.68	Torque limit lvl seq 3	20 ... 200%	0	220	150%	
08.69	Torque tune seq 3	0 ... 1000%	0	221	100%	
08.70	Torque ctrl gain seq 3	0.01 ... 10.00	2	222	0.02	
<b>09</b>	<b>Automatic restart</b>					
09.01	Auto-reset delay time	0 ... 3600 s	0	223	10 s	
09.02	Auto-restart	On, Off	0	224	Off	
09.03	Auto-restart max attempts	1 ... 10	0	225	5	
<b>10</b>	<b>Internal IO</b>					
10.01	In0 function	None, Reset, Enable, Slow speed forward, Slow speed reverse, Motor heating, Stand still brake, Start reverse, User defined protection, Emergency mode (active high), Emergency mode (active low), Fieldbus disable control, Start 1, Start 2, Start 3. Switch to remote control, Cancel brake, Pump cleaning automatic, Pump cleaning forward, Pump cleaning backward, Hold in Remote (Active High), Hold in Remote (Active Low), Lock Parameters (Active High), Lock Parameters (Active Low)	0	130	Reset	
10.02	In1 function	Same settings as for In0 function.	0	131	None	
10.03	In2 function	Same settings as for In0 function.	0	132	None	
10.04	K4 function	None, Run, Top of ramp, Event group 0, Event group 1, Event group 2, Event group 3, Event group 4, Event group 5, Event group 6, Sequence 1 RUN, Sequence 2 RUN, Sequence 3 RUN, Sequence 1 TOR, Sequence 2 TOR, Sequence 3 TOR, Run reverse, Ready to start, Fieldbus[%]	0	133	Run	
10.05	K5 function	Same settings as for K4 function.	0	134	Top of ramp	
10.06	K6 function	Same settings as for K4 function.	0	135	Event group 0	
10.07	AO reference	0-10 mA, 0-20 mA, 4-20 mA, 0-10 V	0	137	4-20 mA	
10.08	AO type	Motor current [A], Mains voltage [V], Active power [kW], Active power [HP], Reactive power [kVAR], Apparent power [kVA], Active energy [kWh], Reactive energy [kVArh], COS Φ, Motor temperature [%], Thyristor temperature [%], Motor voltage [%], Mains frequency [Hz], PT100 temperature [centigrade], PTC resistance [Ω], Fieldbus[%]	0	138	Motor current [A]	
10.09	AO max value	0 ... 1000000	0	139	500	
10.10	AO min value	0 ... 1000000	0	140	0	
10.11	Ext therm sensor - ID	No sensor, PTC element, 3-wire PT100, 2-wire PT100, Bi-metal switch (NC), Bimetal switch (NO)	0	226	No sensor	

Parameter number	Description	Setting range	Number of decimals	Fieldbus ID	Default value	Actual setting
<b>11</b>	<b>External IO</b>					
11.01	1DI0 function	None, Reset, Enable, Slow speed forward, Slow speed reverse, Motor heating, Stand still brake, Start reverse, User defined protection, Emergency mode (active high), Emergency mode (active low), Fieldbus disable control, Start 1, Start 2, Start 3. Switch to remote control, Cancel brake, Pump cleaning automatic, Pump cleaning forward, Pump cleaning backward, Hold in Remote (Active High), Hold in Remote (Active Low), Lock Parameters (Active High), Lock Parameters (Active Low)	0	145	None	
11.02	1DI1 function	Same settings as for 1DI0 function.	0	146	None	
11.03	1DI2 function	Same settings as for 1DI0 function.	0	147	None	
11.04	1DI3 function	Same settings as for 1DI0 function.	0	148	None	
11.05	1DI4 function	Same settings as for 1DI0 function.	0	149	None	
11.06	2DI5 function	Same settings as for 1DI0 function.	0	150	None	
11.07	2DI6 function	Same settings as for 1DI0 function.	0	151	None	
11.08	2DI7 function	Same settings as for 1DI0 function.	0	152	None	
11.09	1DO0 function	Same settings as for 1DI0 function.	0	153	None	
11.10	1DO1 function	Same settings as for 1DI0 function.	0	154	None	
11.11	2DO2 function	Same settings as for 1DI0 function.	0	155	None	
11.12	2DO3 function	Same settings as for 1DI0 function.	0	156	None	
11.13	1A00 reference	0-10 mA, 0-20 mA, 4-20 mA, 0-10 V	0	157	4-20 mA	
11.14	1A00 type	Motor current [A], Mains voltage [V], Active power [kW], Active power [HP], Reactive power [kVAr], Apparent power [kVA], Active energy [kWh], Reactive energy [kVArh], COS $\phi$ , Motor temperature [%], Thyristor temperature [%], Motor voltage [%], Mains frequency [Hz], PT100 temperature [centigrade], PTC resistance [ $\Omega$ ], Fieldbus[%]	0	158	Motor current [A]	
11.15	1A00 max value	0 ... 1000000	0	159	500	
11.16	1A00 min value	0 ... 1000000	0	160	0	
<b>12</b>	<b>Communication</b>					
12.01	Com3 function	None, Test, Modbus RTU slave. Extension I/O	0	26	Test	
12.02	FB interface connector	FbPlug, Modbus RTU, Anybus, None	0	32	None	
12.03	Fieldbus control	On, Off	0	45	Off	
12.04	Fieldbus address	0 ... 65535	0	51	0	
12.05	Fieldbus IP address	0.0.0.0 ... 255.255.255.255	0	58	0.0.0.0	
12.06	Fieldbus IP gateway	0.0.0.0 ... 255.255.255.255	0	59	0.0.0.0	
12.07	Fieldbus IP netmask	255.255.255.000	0	83	255.255.255.0	
12.08	Fieldbus IP DHCP client	On, Off	0	92	Off	
12.09	FB baud rate	1200, 2400, 4800, 9600, 19200, 38400, 57600, 76800, 115200, 125000, 250000, 500000, auto	0	185	19200	
12.10	FB parity	No parity, Odd parity, Even parity	0	136	Even parity	
12.11	FB stop bits	1 Stop bit, 2 Stop bits	0	141	1 Stop bit	

Parameter number	Description	Setting range	Number of decimals	Fieldbus ID	Default value	Actual setting
12.12	The functions of the programmable Digital inputs are controlled by the parameters Fieldbus DI 1 through Fieldbus DI 10. The following functions are available for selection:	None, Start feedback, Stop feedback, Fault reset feedback, Slow speed rev feedback, Slow speed forw feedback, Start 1 feedback, Start 2 feedback, Start 3 feedback, Motor heating feedback, User defined feedback, Stand-still brake feedback, Emergency mode feedback, Start reverse feedback, Run status, TOR status, Line, Phase sequence, Event group 0 status, Event group 1 status, Event group 2 status, Event group 3 status, Event group 4 status, Event group 5 status, Event group 6 status, Sequence 1 Run status, Sequence 2 Run status, Sequence 3 Run status, Sequence 1 TOR status, Sequence 2 TOR status, Sequence 3 TOR status, Run reverse status, Enable status, Digital In0 status, Digital In1 status, Digital In2 status, Local control status, Cancel brake status, Pump cleaning auto status, Pump cleaning forward status, Pump cleaning backward status	0	142	Run status	
12.13	Fieldbus DI 2	Same settings as for Fieldbus DI 1.	0	143	TOR status	
12.14	Fieldbus DI 3	Same settings as for Fieldbus DI 1.	0	144	Line	
12.15	Fieldbus DI 4	Same settings as for Fieldbus DI 1.	0	161	Phase sequence	
12.16	Fieldbus DI 5	Same settings as for Fieldbus DI 1.	0	162	Start feedback	
12.17	Fieldbus DI 6	Same settings as for Fieldbus DI 1.	0	163	Stop feedback	
12.18	Fieldbus DI 7	Same settings as for Fieldbus DI 1.	0	164	Event group 0 status	
12.19	Fieldbus DI 8	Same settings as for Fieldbus DI 1.	0	165	Event group 1 status	
12.20	Fieldbus DI 9	Same settings as for Fieldbus DI 1.	0	166	Event group 2 status	
12.21	Fieldbus DI 10	Same settings as for Fieldbus DI 1.	0	167	Event group 3 status	
12.22	Fieldbus AI 1	None, Phase L1 current, Phase L2 current, Phase L3 current, Active power (HP), Active power, Apparent power, Mains voltage, Power factor, Motor voltage, Active energy (resettable), EOL time to trip, Mains frequency, Max phase current, Motor current, Motor run time (resettable), Motor temperature, Motor temperature percent, Number of starts (resettable), Phase sequence, PT100 temperature, PTC resistance, Reactive energy (resettable), Reactive power, Remaining time to start, Thyristor temperature, Thyristor temperature percent, EOL time to cool, Top event code, Motor current percent, Thyristor run time (resettable), Motor connection, Phase L1 current (high range), Phase L2 current (high range), Phase L3 current (high range), Active power (HP) (high range), Active power (high range), Apparent power (high range), Reactive power (high range), Max phase current (high range), Motor current (high range), Active energy (high range), Reactive energy (high range), Number of starts (high precision)	0	168	Phase L1 current	
12.23	Fieldbus AI 2	Same settings as for Fieldbus AI 1.	0	169	Phase L2 current	

Parameter number	Description	Setting range	Number of decimals	Fieldbus ID	Default value	Actual setting
12.24	Fieldbus AI 3	Same settings as for Fieldbus AI 1.	0	172	Phase L3 current	
12.25	Fieldbus AI 4	Same settings as for Fieldbus AI 1.	0	174	Max phase current	
12.26	Fieldbus AI 5	Same settings as for Fieldbus AI 1.	0	177	Mains frequency	
12.27	Fieldbus AI 6	Same settings as for Fieldbus AI 1.	0	178	Motor voltage	
12.28	Fieldbus AI 7	Same settings as for Fieldbus AI 1.	0	179	Motor temperature percent	
12.29	Fieldbus AI 8	Same settings as for Fieldbus AI 1.	0	180	Number of starts (resettable)	
12.30	Fieldbus AI 9	Same settings as for Fieldbus AI 1.	0	183	Motor run time (resettable)	
12.31	Fieldbus AI 10	Same settings as for Fieldbus AI 1.	0	186	Top event code	
12.32	Allow CIP reset	Yes, No	0	322	No	
12.33	Fieldbus BACnet Device Instance	0 ... 4194303	0	323	4194303	
12.34	BACnet FDR IP address	0.0.0.0 ... 255.255.255.255	0	324	0.0.0.0	
12.35	BACnet foreign device registration UDP port	1 ... 65535	0	325	47808	
12.36	BACnet foreign device registration time interval	0 ... 65535 s	0	326	0 s	
12.37	Fieldbus AO 1	FBT argument 2, Internal analog out	0	327	FBT argument 2	
12.38	Fieldbus AO 2	FBT argument 3, External analog out	0	328	FBT argument 3	
12.39	Change SNMP community string	Yes, No	0	357	No	
12.40	SNMP community string part 1	0 ... 4294967295	0	358	1094861357	
12.41	SNMP community string part 2	0 ... 4294967295	0	359	1347638360	
<b>13</b>	<b>Protections list 1</b>					
13.01	EOL mode	Normal, Dual	0	55	Normal	
13.02	EOL class	10A, 10, 20, 30	0	56	10	
13.03	EOL dual class	10A, 10, 20, 30	0	57	10A	
13.04	EOL out	Eventgroup 0 ... 6	0	84	0000010	
13.05	EOL operation	Off, Stop-Manual, Stop-Automatic, Indication	0	227	Stop-Manual	
13.06	Locked rotor level	0.5 ... 8.0 x I <sub>e</sub>	1	54	4.0 x I <sub>e</sub>	
13.07	Locked rotor trip time	0.20 ... 10.00 s	2	53	1.00 s	
13.08	Locked rotor delay time	1.00 ... 30.00 s	2	52	5.00 s	
13.09	Locked rotor out	Eventgroup 0 ... 6	0	85	0000010	
13.10	Locked rotor op	Off, Stop-Manual, Stop-Automatic, Indication	0	228	Off	
13.11	Max no of starts per hour	1 ... 100	0	229	6	
13.12	Max no of starts per hour out	Eventgroup 0 ... 6	0	230	0000010	
13.13	Max no of starts per hour op	Off, Stop-Manual, Stop-Automatic, Indication	0	231	Off	
<b>14</b>	<b>Protections list 2</b>					
14.01	Curr underload level	0.3 ... 0.9 x I <sub>e</sub>	1	232	0.5 x I <sub>e</sub>	
14.02	Curr underload trip time	0 ... 30 s	0	233	10 s	
14.03	Curr underload delay time	0 ... 30 s	0	234	5 s	
14.04	Curr underload out	Eventgroup 0 ... 6	0	87	0000010	
14.05	Curr underload op	Off, Stop-Manual, Stop-Automatic, Indication	0	235	Off	
14.06	Pwr factor underload level	0.00 ... 1.00	2	236	0.50	
14.07	Pwr factor underload trip time	0 ... 30 s	0	237	10 s	
14.08	Pwr factor underload delay time	0 ... 30 s	0	238	5 s	
14.09	Pwr factor underload out	Eventgroup 0 ... 6	0	86	0000010	

Parameter number	Description	Setting range	Number of decimals	Fieldbus ID	Default value	Actual setting
14.10	Pwr factor underload op	Off, Stop-Manual, Stop-Automatic, Indication	0	239	Off	
14.11	Curr imb level	10 ... 80%	0	61	80%	
14.12	Curr imb trip time	1 ... 30 s	0	63	10 s	
14.13	Curr imb delay time	1 ... 30 s	0	62	5 s	
14.14	Curr imb out	Eventgroup 0 ... 6	0	64	0000010	
14.15	Curr imb operation	Off, Stop-Manual, Stop-Automatic, Indication	0	60	Off	
<b>15</b>	<b>Protections list 3</b>					
15.01	Overvoltage level	170 ... 850 V	0	67	760 V	
15.02	Overvoltage trip time	0.1 ... 100.0 s	1	65	1.0 s	
15.03	Overvoltage out	Eventgroup 0 ... 6	0	68	0000010	
15.04	Overvoltage op	Off, Stop-Manual, Stop-Automatic, Indication	0	66	Off	
15.05	Undervoltage level	165 ... 760 V	0	71	165 V	
15.06	Undervoltage trip time	0.1 ... 100.0 s	1	69	1.0 s	
15.07	Undervoltage op	Off, Stop-Manual, Stop-Automatic, Indication	0	70	Off	
15.08	Undervoltage out	Eventgroup 0 ... 6	0	72	0000010	
15.09	Voltage imb level	1 ... 100%	0	77	10%	
15.10	Voltage imb out	Eventgroup 0 ... 6	0	78	0000010	
15.11	Voltage imb op	Off, Stop-Manual, Stop-Automatic, Indication	0	76	Off	
15.12	Voltage imb trip time	1 ... 100 s	0	329	10 s	
<b>16</b>	<b>Protections list 4</b>					
16.01	Phase rev out	Eventgroup 0 ... 6	0	89	0000010	
16.02	Phase rev operation	Off, Stop-Manual, Stop-Automatic, Indication	0	240	Off	
16.03	Freq range lower trip lvl	40 ... 72 Hz	0	241	45 Hz	
16.04	Freq range upper trip lvl	40 ... 72 Hz	0	242	66 Hz	
16.05	Freq range trip time	0.0 ... 60.0 s	1	243	5.0 s	
16.06	Freq range out	Eventgroup 0 ... 6	0	91	0000010	
16.07	Freq range operation	Off, Stop-Manual, Stop-Automatic, Indication	0	244	Off	
16.08	Bypass open out	Eventgroup 0 ... 6	0	95	0000010	
16.09	Bypass open operation	Off, Stop-Manual, Stop-Automatic, Indication	0	245	Indication	
16.10	24V output out	Eventgroup 0 ... 6	0	82	0000010	
16.11	24V output operation	Off, Stop-Manual, Stop-Automatic, Indication	0	81	Indication	
16.12	Phase rev expected sequence	L1->L2->L3, L1->L3->L2, Unknown	0	330	L1->L2->L3	
16.13	Bypass open trip time	1 ... 300 s	0	-	10 s	
<b>17</b>	<b>Protections list 5</b>					
17.01	PTC out	Eventgroup 0 ... 6	0	88	0000010	
17.02	PTC op	Off, Stop-Manual, Stop-Automatic, Indication	0	246	Off	
17.03	PT100 2wire res	0.0 ... 100.0 ohm	1	247	5.0 ohm	
17.04	PT100 trip temp	-50 ... 250 °C	0	248	60 °C	
17.05	PT100 reset temp	-50 ... 250 °C	0	240	40 °C	
17.06	PT100 out	Eventgroup 0 ... 6	0	98	0000010	
17.07	PT100 op	Off, Stop-Manual, Stop-Automatic, Indication	0	250	Off	
<b>18</b>	<b>Protections list 6</b>					
18.01	User defined DI status	Active low, Active high	0	251	Active high	
18.02	User defined trip time	0.0 ... 60.0 s	1	252	1.0 s	
18.03	User defined out	Eventgroup 0 ... 6	0	90	0000010	
18.04	User defined op	Off, Stop-Manual, Stop-Automatic, Indication	0	253	Off	
18.05	Ground fault trip time	0.1 ... 1.0 s	1	73	0.5 s	
18.06	Ground fault out	Eventgroup 0 ... 6	0	75	0000010	
18.07	Ground fault op	Off, Stop-Manual, Stop-Automatic, Indication	0	74	Off	
18.08	Too long curr lim trip time	1 ... 600 s	0	254	10 s	
18.09	Too long curr lim out	Eventgroup 0 ... 6	0	255	0000010	
18.10	Too long curr lim op	Off, Stop-Manual, Stop-Automatic, Indication. Fast ramp	0	256	Off	
18.11	Too long start trip time	1.0 ... 500.0 s	1		500.0 s	
18.12	Too long start out	Eventgroup 0 ... 6	0		0000010	

Parameter number	Description	Setting range	Number of decimals	Fieldbus ID	Default value	Actual setting
18.13	Too long start op	Off, Stop-Manual, Stop-Automatic, Indication, Fast ramp	0		Off	
18.14	Auto-restart max delay	2 ... 3600 s	0		3600	
18.15	Auto-restart time-out out	Eventgroup 0 ... 6	0		0000010	
18.16	Auto-restart time-out op	Off, Stop-Manual, Stop-Automatic, Indication	0		Off	
<b>19</b>	<b>Protections list 7</b>					
19.01	HMI failure out	Eventgroup 0 ... 6	0	100	0000010	
19.02	HMI failure op	Off, Stop-Manual, Stop-Automatic, Indication, Switch of HMI control	0	257	Stop-Manual	
19.03	Fieldbus failure out	Eventgroup 0 ... 6	0	97	0000010	
19.04	Fieldbus failure op	Off, Stop-Manual, Stop-Automatic, Indication, Switch to I/O control	0	258	Stop-Manual	
19.05	Ext IO failure trip time	300 ... 30000 ms	0	259	1000 ms	
19.06	Ext IO failure out	Eventgroup 0 ... 6	0	99	0000010	
19.07	Ext IO failure op	Off, Stop-Manual, Stop-Automatic, Indication	0	260	Stop-Manual	
19.12	Fieldbus failure timeout	0.5 ... 60.0 s	1	337	0.5 s	
19.13	IO controller stop out	Eventgroup 0 ... 6	0	365	0000010	
19.14	IO controller stop op	Off, Stop-Manual, Stop-Automatic, Indication	0	366	Off	
<b>20</b>	<b>Warnings list 1</b>					
20.01	EOL level	40.0 ... 99.0%	1	181	90.0%	
20.02	EOL out	Eventgroup 0 ... 6	0	123	0000100	
20.03	EOL warning	On, Off	0	182	Off	
20.04	Locked rotor level	0.2 ... 10.0 x I <sub>ϑ</sub>	1	261	1.2 x I <sub>ϑ</sub>	
20.05	Locked rotor init time	1.0 ... 30.0 s	1	262	5.0 s	
20.06	Locked rotor out	Eventgroup 0 ... 6	0	125	0000100	
20.07	Locked rotor	On, Off	0	263	Off	
20.08	Thyristor OL out	Eventgroup 0 ... 6	0	124	0000100	
20.09	Thyristor OL	On, Off	0	122	Off	
20.10	Locked rotor trip time	0.1 ... 100.0 s	1	-	0.1 s	
<b>21</b>	<b>Warnings list 2</b>					
21.01	Curr underload level	0.4 ... 1.0 x I <sub>ϑ</sub>	1	264	0.8 x I <sub>ϑ</sub>	
21.02	Curr underload trip time	0 ... 30 s	0	265	1 s	
21.03	Curr underload delay time	0 ... 30 s	0	266	5 s	
21.04	Curr underload out	Eventgroup 0 ... 6	0	126	0000100	
21.05	Curr underload	On, Off	0	267	Off	
21.06	Pwr factor underload level	0.00 ... 1.00	2	268	0.70	
21.07	Pwr factor underload trip time	0 ... 30 s	0	269	1 s	
21.08	Pwr factor underload delay time	0 ... 30 s	0	270	5 s	
21.09	Pwr factor underload out	Eventgroup 0 ... 6	0	127	0000100	
21.10	Pwr factor underload	On, Off	0	271	Off	
21.11	Current imb level	10 ... 80%	0	102	70%	
21.12	Current imb out	Eventgroup 0 ... 6	0	103	0000100	
21.13	Current imbalance	On, Off	0	101	Off	
21.14	Current imbalance trip time	0.1 ... 100.0	1		5.0 s	
<b>22</b>	<b>Warnings list 3</b>					
22.01	Overvoltage level	208 ... 760 V	0	104	650 V	
22.02	Overvoltage trip time	0.1 ... 100.0 s	1	105	1.0 s	
22.03	Overvoltage out	Eventgroup 0 ... 6	0	107	0000100	
22.04	Overvoltage	On, Off	0	106	Off	
22.05	Undervoltage level	208 ... 760 V	0	108	208 V	
22.06	Undervoltage trip time	0.1 ... 100.0 s	1	109	0.5 s	
22.07	Undervoltage out	Eventgroup 0 ... 6	0	111	0000100	
22.08	Undervoltage	On, Off	0	110	Off	
22.09	Voltage imb level	1 ... 10	0	119	5	
22.10	Voltage imb out	Eventgroup 0 ... 6	0	120	0000100	
22.11	Voltage imbalance	On, Off	0	118	Off	
22.12	Voltage imbalance trip time	0.1 ... 100.0 s	1		5.0 s	

Parameter number	Description	Setting range	Number of decimals	Fieldbus ID	Default value	Actual setting
<b>23</b>	<b>Warnings list 4</b>					
23.01	EOL time-to-trip time	1 ... 1000 s	0	114	5 s	
23.02	EOL time-to-trip out	Eventgroup 0 ... 6	0	112	0000100	
23.03	EOL time-to-trip	On, Off	0	113	Off	
23.04	THD(U) level	1 ... 10%	0	116	10%	
23.05	THD(U) out	Eventgroup 0 ... 6	0	117	0000100	
23.06	THD(U)	On, Off	0	115	Off	
23.07	Short circuit out	Eventgroup 0 ... 6	0	129	0000100	
23.08	Short circuit	On, Off	0	121	Off	
23.09	THD(U) trip time	0.1 ... 100.0 s	1		10.0 s	
<b>24</b>	<b>Warnings list 5</b>					
24.01	Number of starts limit	1 ... 65535	0	-	65535	
24.02	Number of starts out	Eventgroup 0 ... 6	0	-	0000100	
24.03	Number of starts	On, Off	0	-	Off	
24.07	Phase loss trip time	0.5 ... 100.0	1		3.0	
24.08	Phase loss out	Eventgroup 0 ... 6	0		0000100	
24.09	Phase loss	On, Off	0		Off	
24.10	Motor run time limit	0 ... 100000 h	0		10000 h	
24.11	Motor run time out	Eventgroup 0 ... 6	0		0000100	
24.12	Motor run time	On, Off	0		Off	
24.13	Storage warning out	Eventgroup 0 ... 6	0	362	0000100	
24.14	Storage warning	On, Off	0	363	On	
<b>25</b>	<b>Internal faults</b>					
25.01	Shunt fault out	Eventgroup 0 ... 6	0	42	0000001	
25.02	Shunt fault op	Stop-Manual, Stop-Automatic	0	272	Stop-Manual	
25.03	Short circuit out	Eventgroup 0 ... 6	0	50	0000001	
25.04	Short circuit fault op	Stop-Manual, Stop-Automatic	0	273	Stop-manual	
25.05	Open circuit thyr out	Eventgroup 0 ... 6	0	44	0000001	
25.06	Open circuit thyr op	Stop-Manual, Stop-Automatic	0	274	Stop-Manual	
25.07	Thyristor OL out	Eventgroup 0 ... 6	0	47	0000001	
25.08	Thyristor OL op	Stop-Manual, Stop-Automatic	0	275	Stop-Manual	
25.09	Heatsink over temp out	Eventgroup 0 ... 6	0	48	0000001	
25.10	Heatsink over temp op	Stop-Manual, Stop-Automatic	0	276	Stop-Manual	
25.11	Unspecified fault out	Eventgroup 0 ... 6	0	43	0000001	
25.12	Unspecified fault op	Stop-Manual, Stop-Automatic	0	277	Stop-Manual	
25.13	Electronics failure out	Eventgroup 0 ... 6	0	360	0000001	
25.14	Electronics failure op	Stop-Manual, Stop-Automatic	0	361	Stop-Manual	
<b>26</b>	<b>External faults</b>					
26.01	Phase loss out	Eventgroup 0 ... 6	0	96	0000001	
26.02	Phase loss op	Stop-Manual, Stop-Automatic	0	278	Stop-Manual	
26.03	Bad network out	Eventgroup 0 ... 6	0	36	0000001	
26.04	Bad network op	Stop-Manual, Stop-Automatic	0	279	Stop-Manual	
26.05	Low supply voltage out	Eventgroup 0 ... 6	0	46	0000001	
26.06	Low supply voltage op	Stop-Manual, Stop-Automatic	0	280	Stop-Manual	
26.07	High current out	Eventgroup 0 ... 6	0	49	0000001	
26.08	High current op	Stop-Manual, Stop-Automatic	0	281	Stop-Manual	
26.09	Faulty usage out	Event group 0 ... 6	0	282	Event group 0	
26.10	Fault usage op	Stop-Manual, Stop-Automatic	0	283	Stop-Manual	
26.11	Faulty connection out	Eventgroup 0 ... 6	0	282	0000001	
26.12	Faulty connection op	Stop-Manual, Stop-Automatic	0	283	Stop-Manual	
<b>27</b>	<b>Presentation</b>					
27.01	Language	English, Spanish, Finnish, French, Italian, Dutch, Polish, Portuguese, Russian, Swedish, Turkish, Indonesian, Chinese (simplified Chinese), Arabic, Czech, German, Greek	0	173	English	
27.02	Basic set-up at power on	Yes, No	0	284	Yes	



Parameter number	Description	Setting range	Number of decimals	Fieldbus ID	Default value	Actual setting
<b>28</b>	<b>Service</b>					
28.01	ID	Invalid ID, 30, 37, 45, 60, 72, 85, 105, 142, 170, 210, 250, 300, 370, 470, 570, 720, 840, 1050, 1250	0		-	
28.02	Line contactor close time	0 ... 65535 ms	0	175	250 ms	
28.03	TOR relay delay time	0.0 ... 300.0 s	1	286	0.0 s	
28.04	Start without start command	On / Off	0	287	Off	
28.05	Step down level	10 ... 100%	0	9	80%	
28.06	Torque profile start	Constant setpoint, Linear ramp, Progressive curve, High inertia curve	0	10	Linear ramp	
28.07	Torque finish	30 ... 500%	0	17	100%	
28.08	Torque tune	0 ... 1000%	0	11	100%	
28.09	Torque ctrl gain	0.01 ... 10.00	2	12	0.02	
28.10	Torque PI integration time	0.001 ... 10.000 s	3	13	0.004 s	
28.11	Torque slip	0.1 ... 100%	1	14	1.0%	
28.12	Torque diff	0.1 ... 100%	1	15	2.0%	
28.13	Torque filter time	0.01 ... 10.00 s	2	16	0.02 s	
28.14	Mains lock setting	Automatic lock, 50 Hz manual lock 60 Hz manual lock	0	-	Automatic lock	
28.15	Minimum trig time	0.000 ... 1.000 ms	3	-	0.208 ms	
28.16	Accel adapt U start ramp	On, Off	0	290	Off	
28.17	U start ramp switch level	10 ... 100%	0	-	22%	
28.18	T start ramp switch level	10 ... 100%	0	-	30%	
28.19	Stop ramp switch level	10 ... 100%	0	-	52%	
28.20	In-Line gain	0.0 ... 30.0	1	-	0.0	
28.21	Inside delta gain	0.0 ... 30.0	1	-	3.0	
28.22	Phase loss	On, Off	0	-	On	
28.23	Phase loss during TOR	On, Off	0	-	On	
28.24	Phase loss trip time	20 ... 4000 ms	0	-	500 ms	
28.25	Phase loss trip angle 1	1 ... 240	0	-	12	
28.26	Phase loss trip angle 2	1 ... 240	0	-	70	
28.27	Bad network quality	On, Off	0	-	On	
28.28	Low supply voltage	On, Off	0	-	On	
28.29	High current fault	On, Off	0	-	On	
28.30	Shunt fault	On, Off	0	-	On	
28.31	Short circuit thyristor	On, Off	0	-	On	
28.32	Open circuit thyristor	On, Off	0	-	On	
28.33	Thyristor overload	On, Off	0	-	On	
28.34	Heatsink over temp	On, Off	0	-	On	
28.35	Faulty connection	On, Off	0	-	On	
28.36	Faulty usage	On, Off	0	-	On	
28.37	Close bypass curr I <sub>v</sub>	0.5 ... 4.0 x I <sub>e</sub>	1	-	1.2 x I <sub>e</sub>	
28.38	Simulation motor	M3AA 100L 2 (I <sub>e</sub> = 5.2 A), M3BP 112M 4 (I <sub>e</sub> = 7.4 A), M2AA 180MLA 6G (I <sub>e</sub> = 29.3 A), M2AA 180MLB 4G (I <sub>e</sub> = 39.9 A), M3AA 250SMA 8 (I <sub>e</sub> = 62.3 A), M3AA 200MLB 2 (I <sub>e</sub> = 59.2 A), M2AA 225SMA 2G (I <sub>e</sub> = 74.7 A), M2BP 250SMA 4G (I <sub>e</sub> = 96.6 A), M2BA 280SMB 2L (I <sub>e</sub> = 144.9 A), M2BA 315SMB 4L (I <sub>e</sub> = 221.8 A), M2BA 315MLA 2L (I <sub>e</sub> = 319.6A), M4BP 200MLB 2G (I <sub>e</sub> = 59.3 A), M3BP 315LKB 4K (I <sub>e</sub> = 330.4 A), M3BP 315MLA 2M (I <sub>e</sub> = 255.4 A), M3BP 280MLA 4M (I <sub>e</sub> = 151.5 A), M3BP 355SMC 6K (I <sub>e</sub> = 325.6 A),	0	29	M3AA 250SMA 8 (I <sub>e</sub> = 62.3 A)	
28.39	Simulation load	No load, Linear Load, Progressive load, High inertia load	0	30	Progressive load	
28.40	Simulation connection	Auto, In line, Inside delta UI, Inside delta IU, Two phase (L1 shorted), Two phase (L2 shorted), Two phase (L2 shorted), Unknown	0	303	In line	

Parameter number	Description	Setting range	Number of decimals	Fieldbus ID	Default value	Actual setting
28.41	System mode	Normal, Demo, Small motor	0	31	Normal	
28.42	Limp mode	On, Off	0	25	Off	
28.43	Motor connection	Auto, In line, Inside delta UI, Inside delta IU, Two phase (L1 shorted), Two phase (L2 shorted), Two phase (L2 shorted), Unknown	0	27	Auto	
28.48	Disable service profile	Yes, No	0		No	
28.49	Shunt fault trip time	0.1 ... 120.0 s	1		5.0 s	
28.50	Shunt fault trip level	0.1 ... 100.0%	1		3.0%	
28.52	Auxiliary condition	On, Off	0		Off	
28.55	Fast take-off	Off, On	0	355	Off	
28.63	Flux support min speed	10 ... 100%	0	0	35%	
28.64	Electronics failure	On, Off	0	-	On	
28.65	By-pass open detection voltage	2 ... 1000 V	0	-	15 V	
<b>29</b>	<b>Pump clean</b>					
29.01	Pump clean reverse speed	Fast jog, Jog, Creep	0	306	Jog	
29.02	Pump clean reverse strength	10 ... 100%	0	307	45%	
29.03	Pump clean forward start mode	Voltage ramp, Torque ramp, Full voltage start	0	308	Full voltage start	
29.04	Pump clean auto forward time	1.0 ... 100.0 s	1	309	5.0 s	
29.05	Pump clean auto reverse time	1.0 ... 100.0 s	1	310	5.0 s	
29.06	Pump clean brake strength	20 ... 100%	0	311	45%	
29.07	Pump clean brake timeout	1.0 ... 100.0 s	1	312	10.0 s	
29.08	Pump clean stop mode	Voltage ramp and brake, Torque ramp and brake, Dynamic brake	0	313	Torque ramp and brake	

# 8 Communication

<b>8.1 Built in modbus RTU</b>	146
<hr/>	
<b>8.2 Anybus CompactCom (option)</b>	146
<hr/>	
8.3.1 Instructions	147
8.2.2 Necessary components	146
<hr/>	
<b>8.3 ABB Fieldbus plug interface (option)</b>	147
<hr/>	
8.3.1 Instructions	147
8.3.2 Necessary components	147
<hr/>	
<b>8.4 MINI USB interface</b>	147
<hr/>	

## 8.1 Built in modbus RTU

The PSTX Softstarter has a non-isolated RS485 physical interface, com 3, for external devices with support for RS485 based communication.

You can use this interface to control the Softstarter, get status information, and for the upload and download of parameters.

The Softstarter uses the RS485 interface for a modbus RTU slave connection.

### 8.1.1 Instructions

Instructions for the set-up of input and output telegrams, parameter settings, instructions, etc. are available at:

<https://solutions.abb/softstarters>

- Built-in Modbus RTU 1SFC132089M0201

## 8.2 Anybus CompactCom (option)

The PSTX Softstarter has an interface on the front, com 1, for connecting the Anybus CompactCom (CC) module, used for Fieldbus communication. You can use this interface to control the Softstarter, get status information, and for the upload and download of parameters.



### INFORMATION

When fastening the module into the com1 port, make sure that the module is properly aligned into the com 1 and the socket prior to applying any force. Rough handling and/or excessive force in combination with misalignment may cause mechanical damage to the module and/or the com1 and socket.



### INFORMATION

The ports used for communication are the standard ports for each Ethernet based communication protocol. Ethernet/IP: TCP port number 44818 : UDP port number 2222  
The PROFINET use any of the standardized ports.  
Modbus TCP: TCP port number 502

When replacing or retrofitting an Anybus communication module with any of the modules listed in **Table 1** a software upgrade of the PSTX Softstarter with a control board (CB) firmware version below v.1.36.2 is needed to ensure compatibility. The ordering code and product ID is found printed on the Anybus module package and product label respectively. Please refer to section 6.4.5 and 9.3 for instructions on how to both determine and upgrade the PSTX Softstarter firmware if necessary.

Table 1

Module	Ordering Code	Product ID
Anybus Ethernet/IP (Dual ports)	1SFA899300R1006	AB6966-B
Anybus Modbus TCP (Dual ports)	1SFA899300R1008	AB6967-B

### 8.2.1 Instructions

Instructions for the set-up of input and output telegrams, parameter settings, instructions, etc. are available at:

<https://solutions.abb/softstarters>

- DeviceNet 1SFC132084M0201
- Profibus (DPV1) 1SFC132085M0201
- Modbus RTU 1SFC132086M0201
- Modbus TCP 1SFC132087M0201
- EtherNet/IP 1SFC132088M0201
- Profinet 1SFC132094M0201
- BACnet MS/TP 1SFC132381M0201
- BACnet IP 1SFC132381M0201
- EtherCAT 1SFC132382M0201

### 8.2.2 Necessary components

These Anybus CC connection devices are available:

- DeviceNet
- Profibus (DPV1)
- Modbus RTU
- Modbus TCP
- EtherNet/IP
- Profinet
- BACnet MS/TP
- BACnet IP
- EtherCAT

## 8.3 ABB Fieldbus plug interface (option)

The PSTX Softstarter has an interface, com 2, on the front for connecting the ABB Fieldbus Plug Adapter (FBPA) used for Fieldbus communication.

You can use this interface to control the Softstarter, get status information, and for the upload and download of parameters.

The interface between the Softstarter and the FieldBus Plug is independent of the Fieldbus protocol used. Independent of Softstarter type or delivery date, you can connect 1 of the available Fieldbus protocols, because this is specified in the FieldBus Plug itself.

Connect the Fieldbus communication plug to the ABB Fieldbus Plug Adapter (FBPA).

Make sure that the plug is in the correct position and tighten the screw with 0,8 Nm (7,1 lb in) and additional 1/4 turn.

These Fieldbus protocols are available:

- DeviceNet
- Profibus (DPV0/DPV1)
- Modbus RTU

### 8.3.1 Instructions

Instructions for the set-up of input and output telegrams, parameter settings, instructions, etc. are available at:

**<https://solutions.abb/softstarters>**

- DeviceNet 1SFC132090M0201
- Profibus (DPV0/DPV1) 1SFC132091M0201
- Modbus RTU 1SFC132092M0201

### 8.3.2 Necessary components

To connect the PSTX Softstarter to a Fieldbus system, these components are necessary:

- ABB Fieldbus Plug Adapter, for presenting Fieldbus protocol (make sure that the cable length is sufficient).
- Connectors for bus connection.
- End plug (some protocols).
- Software for PLC set-up.

## 8.4 MINI USB interface

The PSTX Softstarter has an USB interface for communication with PC. The USB interface is on the front of the movable HMI.

You can use this interface to get status information, and for the upload and download of parameters.



# 9 Maintenance

9.1 Regular maintenance	150
9.2 Service and repair	150
9.3 Firmware upgrade	150

This chapter gives a description of basic maintenance for the PSTX Softstarter.



### WARNING

Dangerous voltage: Can cause death or serious injury.

Make sure that the Softstarter is de-energized before doing maintenance, service or repair.

Do not open the Softstarter or touch live parts when the main and supply voltage is connected.



### WARNING

Service and repair must be done by authorized personnel only. Note that unauthorized repair has an effect on safety and warranty.



### INFORMATION

ABB personnel must obey the instructions in **ABB CISE 15.4**.

## 9.1 Regular maintenance

- Make sure that all installation bolts/screws are fastened. Tighten if necessary.
- Tighten the terminal screws and bolts on the connection bars, if necessary.  
For tightening torques, see chapter

### 5.1.1.1 Tightening torques and cable dimensions.



### WARNING

- Make sure that the Softstarter is de-energized before tightening the bolts/screws.

- Make sure that all connections of control- and supply circuits are fastened.  
For tightening torques, see chapter **5.1.1.1 Tightening torques and cable dimensions**.
- If the Softstarter is installed inside a cabinet, do a check of the external filters. Clean them, if necessary.
- Make sure that the airways are free from dirt and dust.



### WARNING

Do not use pressurized air to clean the Softstarter.

- Check that the fans are running for at least 3 minutes after each start and stop cycle.
- Make sure that the fan works and rotates freely. The blades must rotate without resistance.
- Do a check of the time of the Softstarter and adjust if necessary.
- In case of a fault, or if a fault cannot be reset, see chapter **10 Troubleshooting**.

## 9.2 Service and repair

For repair of the PSTX Softstarter, speak to your ABB reseller/Office or speak to ABB through <https://solutions.abb/softstarters>



### WARNING

A short circuit on the load side of the Softstarter can cause large damage to the unit and cause danger to personnel.

By using a correctly rated short circuit protection device, e.g. a fuse or a circuit breaker, the damage is limited to 1 of the 2 categories, specified in IEC 60947-4-2 and EN 60947-4-2:

Type 1: The Softstarter can have damage and it can be necessary to replace some or all parts.

Type 2: The device can operate after a short circuit.

Type 2: Use a semiconductor fuse to get coordination. A coordination table is found in the catalogue and online through:

<https://solutions.abb/softstarters>

For warranty for damage on the thyristors, the coordination type 2 is necessary.

## 9.3 Firmware upgrade

For firmware upgrade see document Softstarter Firmware Upgrade- 2CMT001197D0169.



# 10 Troubleshooting

10.1 General	152
10.2 Troubleshooting	152
10.3 Overview of faults, protections and warnings	155
10.4 Protection indication shown on screen	157
10.5 Fault indication shown on screen	158
10.6 Warning indication shown on screen	161

## 10.1 General

Use this chapter when problems occur with the Softstarter or the application.



### WARNING

Dangerous voltage: Can cause death or serious injury. Always set the power switch to off and lock out all power to this device before you start to work on the equipment.



### WARNING

Make sure that the Softstarter is de-energized before you do maintenance.  
Do not open the Softstarter or touch live parts when the main and supply voltage is connected.



### INFORMATION

ABB personnel must follow the **ABB CISE 15.4** instructions

The Softstarter indicates a fault with LED Fault, and the screen shows which type of fault occurred. When a protection is on, the LED Protection illuminates and the screen shows which type of protection is active.

When a warning occurs, the screen shows the type of warning.

In this chapter you can also find issues that the Softstarter does not show, such as humming sounds.

## 10.2 Troubleshooting

**Table 1** Troubleshooting

Status	Possible cause	Solution
Motor humming / starts without given start signal.	Bypass relay closed, because of inaccurate handling. (PSTX30...170 only).	<ul style="list-style-type: none"> <li>Disconnect the operation voltage and the control supply voltage. Remove USB cable from the computer if connected. Connect voltage in this sequence:               <ol style="list-style-type: none"> <li>Control supply voltage on terminals 1 and 2. See chapter <b>5.1.2 Control supply and control circuit</b>.</li> <li>Wait 4 seconds, and then connect operation voltage on terminals L1, L2 and L3.</li> </ol> </li> <li>If the fault stays, speak to your ABB Sales Office.</li> </ul>
	Bypass contactor/relay stuck in closed position.	<ul style="list-style-type: none"> <li>Speak to your ABB Sales Office.</li> </ul>
	Shorted thyristor.	<ul style="list-style-type: none"> <li>Speak to your ABB Sales Office.</li> </ul>
Bad motor sound during start.	The motor connection is not correct.	<ul style="list-style-type: none"> <li>Examine and correct the wiring. Check jumper connectors in motor's terminal box. Connect the control supply voltage. Refer to the circuit diagram. See chapter <b>11 Wiring and application diagrams</b>.</li> </ul>
	Inside delta connection and one gate cable disconnected	<ul style="list-style-type: none"> <li>Make sure all six gate cables are connected.</li> </ul>
	Incorrect ramp time for start.	<ul style="list-style-type: none"> <li>Try different ramp times (some adjustments can be necessary for best result). See chapter <b>7 Functions</b>.</li> </ul>

Status	Possible cause	Solution
<b>Bad motor sound during start.</b>	Incorrect Initial/End level.	<ul style="list-style-type: none"> <li>Try different settings for the parameter Initial /End Voltage. See chapter <b>7 Functions</b>, or speak to your ABB Sales Office.</li> </ul>
	Incorrect Current limit level or Torque limit level.	<ul style="list-style-type: none"> <li>Try different settings for the parameter Current limit level or Torque limit level. See chapter <b>7 Functions</b>, or speak to your ABB Sales Office.</li> </ul>
	The motor is too small. (Current is out of measuring range.)	<ul style="list-style-type: none"> <li>Make sure that you have the correct Softstarter for this motor size. For test purposes you can use small motor mod. See chapter <b>7 Functions</b>.</li> </ul>
	Thyristor conductivity is bad.	<ul style="list-style-type: none"> <li>Contact your ABB Sales Office.</li> </ul>
	Incorrect ramp time for start.	<ul style="list-style-type: none"> <li>Make sure that you have the correct Softstarter for this motor size. For test purposes you can use small motor mode. See chapter <b>7 Functions</b>.</li> </ul>
	Start and stop command given at the same time.	<ul style="list-style-type: none"> <li>Make sure that start and stop command is not given at the same time.</li> </ul>
	The operation voltage is below 175 V.	<ul style="list-style-type: none"> <li>Do a check of the operation voltage.</li> </ul>
<b>Motor does not start when given start command by the hardwire inputs.</b>	Control wiring is not correct. Start and stop command given at the same time. Keypad is in Local control mode.	<ul style="list-style-type: none"> <li>Do a check of the connections for start and stop.</li> <li>Make sure that start and stop command is not given at the same time.</li> <li>Make sure that the keypad is not in Local Control mode.</li> <li>Push the R/L-key to change to Remote Control mode.</li> <li>Make sure that parameter Fieldbus control is set to No.</li> <li>Do a reset on an active event.</li> <li>Reset tripping events.</li> </ul>
<b>Motor does not start with Fieldbus.</b>	Softstarter has tripped on fault or protection.	<ul style="list-style-type: none"> <li>Do a reset on an active event.</li> <li>Reset tripping events.</li> </ul>
	Softstarter is in Local mode.	<ul style="list-style-type: none"> <li>Make sure that the Stop bit of the binary output telegram setting is set to 1.</li> <li>Make sure that parameters match between the PLC and the Softstarter Fieldbus documentation for the used Fieldbus protocol.</li> <li>Make sure that the Auto mode bit of the binary output telegram setting is set to 1.</li> <li>Do a check if the HMI is set to remote mode.</li> <li>Make sure that the Local Mode digital input on the ABB FieldBus Plug adapter is set to Remote.</li> <li>Make sure that Fieldbus disable control in DI is not connected.</li> <li>Make sure that the Fieldbus control parameter is set to On.</li> </ul>
	Fieldbus operation when fault parameter is set to Change to I/O control.	<ul style="list-style-type: none"> <li>If the parameter Fieldbus failure op is set to Change to I/O control when fault occurs, there is a 10 seconds delay before you can re-start after communication is connected.</li> </ul>

Status	Possible cause	Solution
Loading of parameters with Fieldbus does not work correctly.	Fieldbus settings.	<ul style="list-style-type: none"> <li>• Make sure that parameters match between the PLC and the Softstarter Fieldbus documentation for the used Fieldbus protocol.</li> <li>• Make sure that the Auto mode bit of the binary output telegram setting is 1.</li> <li>• Do a check if the HMI is set to remote control.</li> <li>• Make sure that the Local Mode digital input on the ABB FieldBus Plug adapter is set to Remote.</li> <li>• Make sure that Fieldbus disable control in DI is not connected.</li> <li>• Make sure that the Fieldbus control parameter is set to On.</li> </ul>
Shown phase currents in screen do not agree with motor current.	Inside Delta connection.	<ul style="list-style-type: none"> <li>• If the Softstarter is connected Inside Delta, the phase currents shown are = 58% (<math>1/\sqrt{3}</math>) of the motor current.</li> </ul>
Shown current in screen is not stable.	The motor is too small. The load on the motor is too small. (Current is out of measuring range.)	<ul style="list-style-type: none"> <li>• Make sure that you have the correct Softstarter for this motor size..</li> </ul>
Dark screen and LED is active	Power save mode.	<ul style="list-style-type: none"> <li>• Touch a key on the keypad.</li> </ul>
Blank screen and no LED is active	Supply voltage is not connected.  <ul style="list-style-type: none"> <li>• The RJ45 plug is missing between the HMI and the Softstarter.</li> <li>• RJ45 Network cable is damaged.</li> </ul>	<ul style="list-style-type: none"> <li>• Connect the Supply voltage. Refer to the circuit diagram.</li> <li>• If problem stays, speak to your ABB Sales Office.</li> <li>• Do a check of the RJ45 plug.</li> <li>• Do a check of the RJ45 Network cable</li> </ul>

## 10.3 Overview of faults, protections and warnings

This table shows in which state the different indications for protections, faults and warnings can show.

		Event code*	Softstarter states **					Individual function
		(Hexadecimal)	Stand by	Pre-start	Start Ramp	Top of ramp	Stop ramp	
Protections	Electronic overload	P0Fxx	X	X	X	X	X	X
	Locked rotor	P10xx				X		
	Phase reversal	P11xx		X	X	X	X	X
	Current imbalance	P12xx				X		
	Current underload	P13xx				X		
	User defined protection	P14xx	X	X	X	X	X	X
	Ground fault	P15xx		X	X	X	X	X
	Overvoltage	P16xx				X		
	Undervoltage	P17xx				X		
	Voltage imbalance	P18xx		X	X	X	X	X
	PT100 protection	P19xx	X	X	X	X	X	X
	PTC protection	P1Axx	X	X	X	X	X	X
	Power factor underload	P1Bxx				X		
	Too long current limit	P1Cxx			X			
	Bypass open	P1Dxx				X		
	Fieldbus communication failure	P1Exx	X	X	X	X	X	X
	24V output	P1Fxx	X	X	X	X	X	X
	HMI failure	P20xx	X	X	X	X	X	X
	Extension I/O failure	P21xx	X	X	X	X	X	X
	Max number of starts per hour	P22xx						
Auto-restart time-out	P31xx	X	X	X	X	X	X	
Too long start time	P32xx			X				
Frequency range	P33xx		X	X	X	X	X	

\*) Only the first 2 digits are important

\*\*) For softstarter states description, see chapter **7.1.2 Softstarter states**

		Event code*	Softstarter states **					
		(Hexadecimal)	Stand by	Pre-start	Start Ramp	Top of ramp	Stop ramp	Individual function
Faults	High current	F02xx	X	X	X	X	X	X
	Phase loss	F03xx		X	X	X	X	X
	Heatsink overtemperature	F04xx	X	X	X	X	X	X
	Bad network quality	F05xx		X	X		X	
	Shunt fault	F06xx	X		X		X	
	Low supply voltage	F07xx	X	X	X	X	X	X
	Thyristor overload	F08xx	X	X	X	X	X	X
	Short circuit thyristor	F09xx		X	X		X	X
	Open circuit thyristor	F0Axx		X	X			X
	Unspecified fault	F0Bxx	X	X	X	X	X	X
	Invalid ID	F0Cxx	X	X	X	X	X	X
	Faulty connection	F0Dxx						
	Faulty usage	F0Exx					X	X
	Electronics failure	F36xx	X	X	X	X	X	X
Warnings	Current imbalance	W23xx				X		
	Current underload	W24xx				X		
	EOL warning	W26xx	X	X	X	X	X	X
	Locked rotor	W27xx				X		
	Overvoltage	W28xx				X		
	Undervoltage	W29xx				X		
	Power factor underload	W2Axx				X		
	THD(U)	W2Bxx				X		
	Thyristor overload	W2Cxx	X	X	X	X	X	X
	Voltage imbalance	W2Dxx		X	X	X	X	X
	Short circuit	W2Exx		X	X		X	X
	EOL time-to-trip	W2Fxx				X		
	Phase loss	W30xx	X					
	Number of starts limit	W34xx	X	X	X	X	X	X
Motor run time limit	W35xx	X	X	X	X	X	X	

\*) Only the first 2 digits are important

\*\*) For softstarter states description, see chapter 7.1.2 Softstarter states

## 10.4 Protection indication shown on screen

For a description of the protections, see chapter **7.17 Protections**.

**Table 2** Protection indication

Status	Code	Possible cause	Solution
Electronic overload	P0Fxx	The motor got an overload because the current is too high during some time. (The load on the motor shaft is too high)	<b>In Line / Inside Delta</b> <b>At start</b> <ul style="list-style-type: none"> <li>Examine start conditions and EOL settings.</li> <li>Examine and correct the reason for the overload.</li> <li>Make sure that Current limit level is not set too low.</li> <li>Make sure that the ramp time for start is not too long.</li> <li>Make sure that correct overload class is used.</li> <li>Make sure that parameter Setting Ie is correct.</li> </ul>
			<b>Continuous run</b> <ul style="list-style-type: none"> <li>Do a check of the rating of the plate for Ie.</li> <li>Do a check of the operation voltage.</li> <li>Use a motor with more power, and a Softstarter rated for higher current.</li> <li>Examine and correct the reason for the overload.</li> <li>Make sure that correct EOL Class is used.</li> </ul>
Locked rotor	P10xx	The motor does not run easily. A possible cause is a damaged bearing or a load stock.	<ul style="list-style-type: none"> <li>Examine the bearings of the motor and load.</li> <li>Make sure that the load runs easily.</li> </ul>
Phase reversal	P11xx	The phase sequence is not correct. Current imbalance between the phases.	<ul style="list-style-type: none"> <li>Change the phase sequence on the line side to (L1-L2-L3).</li> <li>Start the motor again and do a check of the main currents and voltage.</li> </ul>
Current imbalance	P12xx	Current imbalance between the phases.	<ul style="list-style-type: none"> <li>Start the motor again and do a check of the main currents and voltage.</li> </ul>
Current underload	P13xx	The motor current is below the specified value.	<ul style="list-style-type: none"> <li>Examine and correct the reason for the underload.</li> <li>Make sure that the motor current parameter (Ie) is set correctly.</li> </ul>
User defined protection	P14xx	With the programmable digital input and an external device/ sensor the user can use his own specified protection.	<ul style="list-style-type: none"> <li>Set the programmable input signal to inactive state before you reset the protection event.</li> </ul>
Ground fault	P15xx	Equipment protection. In a symmetrical 3-phase system, the sum of the instantaneous line currents is equal to zero. Ground fault indicates if the sum differs more than the specified value. This can indicate a serious condition of the motor.	<ul style="list-style-type: none"> <li>Examine motor cables.</li> <li>Examine the motor.</li> </ul>
Overvoltage	P16xx	The main voltage is too high	<ul style="list-style-type: none"> <li>Do a check of the main voltage.</li> </ul>
Undervoltage	P17xx	The main voltage is too low.	<ul style="list-style-type: none"> <li>Do a check of the main voltage.</li> </ul>
Voltage imbalance	P18xx	Voltage imbalance between the phases.	<ul style="list-style-type: none"> <li>Do a check of the main voltage and start the motor again.</li> </ul>
External thermal sensor - PTC protection - PT100 protection	P1Axx P19xx	The external thermal sensor detected a temperature higher than the trip level in the motor or PT100.	<ul style="list-style-type: none"> <li>Make sure that the PTC, Bi-metal switch or PT100 circuit is closed and that the inputs are connected.</li> <li>Examine and correct the reason for the high temperature.</li> <li>Wait for the temperature of the motor to decrease sufficiently and start again.</li> </ul>

Status	Code	Possible cause	Solution
Power factor underload	P1Bxx	The power factor is below the normal level.	<ul style="list-style-type: none"> <li>Examine and correct the reason for the underload.</li> </ul>
Too long current limit	P1Cxx	The time at current limit is higher than the set value. The starting condition is too heavy for the set current limit.	<ul style="list-style-type: none"> <li>Do a check of the starting conditions and parameters.</li> </ul>
Bypass open	P1Dxx	Bypass contactor or relay does not close when reached TOR.	<ul style="list-style-type: none"> <li>Do a check and speak to your ABB sales office.</li> </ul>
Fieldbus communication failure	P1Exx	There is a communication error between the Softstarter and PLC.	<ul style="list-style-type: none"> <li>Make sure that the FieldBus Plug is connected correctly.</li> <li>Make sure that correct type of FieldBus Plug is used.</li> <li>Make sure that the parameter Fieldbus Type is set for the present Fieldbus type.</li> </ul>
24V output	P1Fxx	The 24V voltage output is overloaded or shorted.	<ul style="list-style-type: none"> <li>Do a check of the connections.</li> </ul>
HMI failure	P20xx	There is a communication error between the Softstarter and the HMI.	<ul style="list-style-type: none"> <li>Do a check of the connections and correct it.</li> </ul>
		The HMI is removed.	<ul style="list-style-type: none"> <li>Put the HMI back.</li> </ul>
Extension I/O failure	P21xx	There is a communication error between the Softstarter and the extension I/O module.	<ul style="list-style-type: none"> <li>Do a check of the connections and correct it.</li> </ul>
Max number of start per hour	P22xx	The Softstarter made more starts than the pre-set limited number of starts.	<ul style="list-style-type: none"> <li>Wait for the next start interval. For parameter, see chapter <b>7 Functions</b>.</li> </ul>
Auto-restart time-out	P31xx	The time between trip and auto-restart attempt exceeds setting.	<ul style="list-style-type: none"> <li>Do a check of the automatic restart parameters and correct it.</li> </ul>
Too long start time	P32xx	The time to soft start the motor is longer than the set value.	<ul style="list-style-type: none"> <li>Do a check of the starting conditions and current limit..</li> </ul>
Frequency range	P33xx	The frequency has been outside the allowed range longer than the allowed time.	<ul style="list-style-type: none"> <li>Do a check of the main voltage.</li> </ul>

## 10.5 Fault indication shown on screen

For a description of the faults, see chapter **7.19 Faults**

**Table 3** Fault indication

Status	Code	Possible cause	Solution
High current	F02xx	A fault current, higher than 8 times the Softstarter rated current, has occurred..	<ul style="list-style-type: none"> <li>Do a check of the circuits and the motor for an insulation fault phase to phase or ground fault.</li> </ul>
Phase loss	F03xx	Voltage to 1 or more phases is missing.	<ul style="list-style-type: none"> <li>Make sure that the mains are connected and that no line contactor or breaker is open.</li> </ul>
		Fuse is blown.	<ul style="list-style-type: none"> <li>Do a check of the fuses for all 3 phases. Replace blown fuse.</li> </ul>
		Power loss on operation current for 1 or multiple phases.	<ul style="list-style-type: none"> <li>Do a check of the operation network supply. Correct it.</li> </ul>
		The line contactor or circuit breaker is open.	<ul style="list-style-type: none"> <li>Do a check of the contactor/breaker or an external switch device. Close it.</li> </ul>
		Line contactor opens too quickly at stop.	<ul style="list-style-type: none"> <li>Control Line contactor with Run signal relay on terminal 4. See <b>chapter 5.1.2.6 Programmable output relay - K4, terminals 4, 5 and 6</b>.</li> <li>Add a time relay before contactor opens.</li> <li>If Stop Ramp is not necessary, set Stop mode to direct stop.</li> </ul>



Status	Code	Possible cause	Solution
Heatsink overtemperature	F04xx	The heatsink temperature is too high. If the fault stays after reset, the heatsink is too hot and the temperature must decrease.	<ul style="list-style-type: none"> <li>• Make sure that the fans work correctly.</li> <li>• Make sure that airways are free from dirt and dust.</li> <li>• Make sure that the ambient temperature is not too high.</li> </ul>
Bad network quality	F05xx	Excessive interference in the operation supply network.	<ul style="list-style-type: none"> <li>• Do a check for harmonics or frequency interference in the supply network and correct supply operation network.</li> </ul>
		Short power loss on all 3 phases in the operation network.	<ul style="list-style-type: none"> <li>• Do a check of the supply operation network. Correct it.</li> </ul>
Shunt fault	F06xx	The Softstarter cannot stop the motor because of internal short circuit.	<ul style="list-style-type: none"> <li>• Speak to ABB sales office for service.</li> </ul>
		Bypass relay closed, because of inaccurate handling. (PSTX30...170 only).	<ul style="list-style-type: none"> <li>• Disconnect operation voltage and control supply voltage. Connect voltage in correct order. <ol style="list-style-type: none"> <li>1. Control supply voltage on terminals 1 and 2. See chapter <b>5.1.2 Control supply and control circuit</b>.</li> <li>2. Wait 4 seconds, and then connect operation voltage on terminals L1, L2 and L3.</li> </ol> </li> <li>• If same fault stays, speak to your ABB Sales Office.</li> </ul>
Low supply voltage	F07xx	The control supply voltage is too low on terminals 1 and 2.	<ul style="list-style-type: none"> <li>• Do a check for voltage dips or interruptions and correct control supply voltage.</li> </ul>
		Short power loss on the control supply network.	<ul style="list-style-type: none"> <li>• Do a check of the control supply network for short interruptions.</li> </ul>
Thyristor overload	F08xx	The thyristors are too hot.	<ul style="list-style-type: none"> <li>• Do a check of the start conditions and the fans.</li> <li>• Decrease current limit if possible.</li> <li>• Let the temperature of the thyristors decrease before you start again.</li> </ul>
Short circuit thyristor	F09xx	One or multiple thyristors are shorted due to: <ul style="list-style-type: none"> <li>- Short circuit in the main circuit</li> <li>- Usage of thyristors outside the softstarter specification</li> <li>- Incorrect size of softstarter</li> </ul>	<ul style="list-style-type: none"> <li>• Speak to your ABB sales office for service.</li> <li>• If possible, measure the resistance on each phase between motor and load side of the Softstarter. If one phase is shorted there might be a shorted thyristor or a welded contactor, see below for test.</li> </ul>
		Incorrect connections	<ul style="list-style-type: none"> <li>• Check motor wiring</li> <li>• Check jumper connectors in motor's terminal box</li> </ul>
		Harmonics outside softstarter specification makes false trip	<ul style="list-style-type: none"> <li>• Measure harmonics levels and reduce them with filters</li> </ul>
		Bypass is closed/welded	<ul style="list-style-type: none"> <li>• Speak to your ABB sales office</li> <li>• Test the bypass contactor: <ol style="list-style-type: none"> <li>1. Disconnect main. Be 100% sure that main will not become active during the test. If it does, the Softstarter can be harmed.</li> <li>2. Maintain supply (100-250 VAC, 50/60 Hz)</li> <li>3. Change parameter 28.41 to demo mode</li> <li>4. Change parameter 28.38 to a motor with I<sub>e</sub> corresponding to the softstarter (62.3 A by default)</li> <li>5. Press L/R button to set it in local mode</li> <li>6. Press green start button to make a "fake start"</li> <li>7. Let it ramp up</li> <li>8. Listen for the bypass relay click</li> <li>9. Measure the voltage and resistance over each phase (between L1-T1, between L2-T2 and between L3-T3) with a megger/multimeter</li> <li>10. The resistance should be close to zero since if the bypass is closed there will be a closed circuit and the bypass relay will work.</li> </ol> </li> </ul>

Status	Code	Possible cause	Solution
Open circuit thyristor	F0Axx	One or multiple thyristors do not conduct.	<ul style="list-style-type: none"> <li>Speak to your ABB sales office for service.</li> </ul>
		The Operation voltage is below 175 V.	<ul style="list-style-type: none"> <li>Make sure that you have the correct Softstarter for this motor size.</li> </ul>
		The motor or load is too small	<ul style="list-style-type: none"> <li>For test purposes you can use small motor mode. See chapter <b>7 Functions</b>.</li> </ul>
		Control card is broken	<ul style="list-style-type: none"> <li>Speak to your ABB sales office</li> </ul>
		The control card has been replaced and the gate cables are not attached	<ul style="list-style-type: none"> <li>Verify the gate cables connections if possible</li> <li>Speak to your ABB sales office for service</li> </ul>
Unspecified fault	F0Bxx	N/A	<ul style="list-style-type: none"> <li>Disconnect the supply voltage (Us). Connect it again and start again.</li> <li>If the same fault stays, speak to your ABB sales office.</li> </ul>
Invalid ID	F0Cxx	ID parameter out of range	<ul style="list-style-type: none"> <li>Cycle the control power (power off and then power on), this will "restart" the Softstarter.</li> <li>If you get Invalid ID after every power off, then the parameters are not set correctly before the Softstarter is power off.</li> <li>Note that changing the ID parameter will result in all le parameters being set to their default value followed by a restart of the device.</li> <li>The reason why we have several le parameters is because of the sequence start function.</li> <li>Procedure on how to restore the ID parameter               <ol style="list-style-type: none"> <li>Set Softstarter ID (parameter 28.01)</li> <li>Wait for the device to restart.</li> </ol> <p>Note: this will result in all le values being set to default. On next power on you won't get the Invalid ID fault.</p> </li> </ul>
Faulty connection	F0Dxx	Motor connection unknown when trying to start motor.	<ul style="list-style-type: none"> <li>Change motor connection from Auto detection to the motor connection that is used (parameter 28.43)</li> </ul>
Faulty usage	F0E01	Inside delta motor connection or one phase shorted when you try to jog forward.	<ul style="list-style-type: none"> <li>Do not use these functions with Inside delta motor connection or one phase shorted.</li> </ul>
	F0E02	Inside delta motor connection or one phase shorted when you try to jog backward.	
	F0E03	Inside delta motor connection or one phase shorted when you try to heat motor.	
	F0E04	Inside delta motor connection or one phase shorted when you try to do a stand still brake.	
	F0E05	Inside delta motor connection or one phase shorted when you try to use a prestart function.	
	F0E06	One phase shorted when you try to use dynamic brake.	
	F0E10	Demo mode when mains three phase voltage is connected.	<ul style="list-style-type: none"> <li>Do not use demo mode when three phase voltage is connected.</li> </ul>
Electronics failure	F36xx	Circuit fault detected during hardware initialization.	<ul style="list-style-type: none"> <li>Speak to your ABB sales office for service.</li> </ul>

## 10.6 Warning indication shown on screen

For a description of the warnings, see chapter **7.18 Warnings**.

**Table 4 Warning indication**

Status	Code	Cause/Possible cause
Current imbalance	W23xx	Current imbalance between the phases is higher than the warning level.
Current underload	W24xx	The motor current is below the warning level. Make sure that the motor current parameter (Ie) is set correctly.
EOL warning	W26xx	The calculated motor temperature is higher than the warning level.
Locked rotor	W27xx	The motor current is higher than the warning level. A damaged bearing or a stuck load can be possible causes.
Overvoltage	W28xx	The RMS phase to phase voltage in the line side is higher than the adjustable value.
Undervoltage	W29xx	The RMS phase to phase voltage in the line side decreased below the adjustable value.
Power factor underload	W2Axx	The power factor decreased below the adjustable value during continuous operation.
THD(U)	W2Bxx	THD(U) is higher than the warning level. Do a check of the quality of the network.
Thyristor overload	W2Cxx	The calculated thyristor temperature is higher than the warning level
Voltage imbalance	W2Dxx	Voltage imbalance between the phases is higher than the warning level.
Short circuit	W2Exx	There is an internal short circuit and the Softstarter runs in limp mode. See chapter 7 Functions.
EOL time-to-trip	W2Fxx	The predicted time before EOL trip is at the warning level.
Phase loss	W30xx	Voltage to one or more phases missing. Check that the mains are connected and that no line contactor or breaker is open.
Number of starts limit	W34xx	The number of starts exceeds the warning level. Time for service! The warning will stay active until the Number of starts (resettable) value have been reset. Use menu: Menu → Settings → Reset to defaults → Reset operating data and select Number of starts (resettable) to perform the reset.
Motor run time limit	W35xx	The Motor runtime exceeds warning level. Time for service! The warning will stay active until the Motor run time (resettable) value have been reset. Use menu: Menu → Settings → Reset to defaults → Reset operating data and select Motor run time (resettable) to perform the reset.



# 11 Wiring and application diagrams

## 11.1 Circuit diagram PSTX

	164
11.1.1 Circuit diagram	
PSTX30...PSTX1250 (IEC version)	164
11.1.2 Circuit diagram	
PSTX30...PSTX1250 (UL version)	164

## 11.2 Application diagrams

	164
11.2.1 Inside Delta	165
11.2.2 Start at optional direction	165
11.2.3 Start at optional direction, alternative	166
11.2.4 With pole change, one winding motor	166
11.2.5 With pole change, two winding motor	167
11.2.6 InLine contactor control	167
11.2.7 Dual motor start	168
11.2.8 Sequence start	169
11.2.9 Softstarter in network with high harmonic disturbances	170

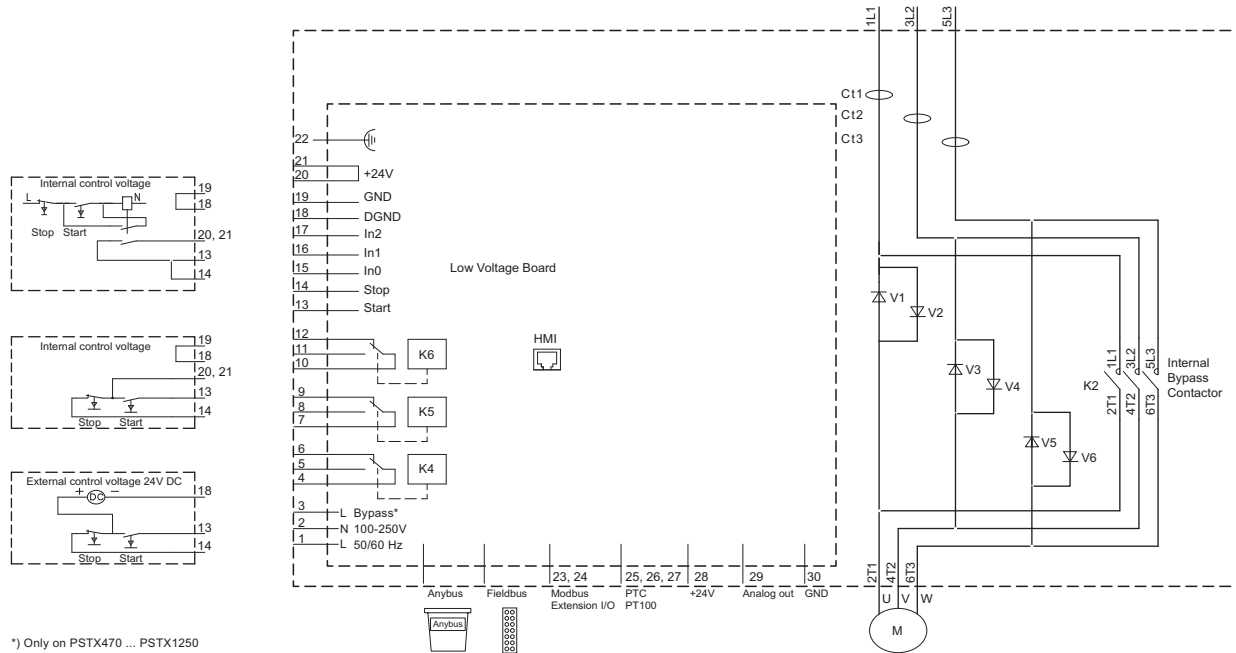
## 11.1 Circuit diagram PSTX

### 11.1.1 Circuit diagram PSTX30...PSTX1250 (IEC version)



#### WARNING

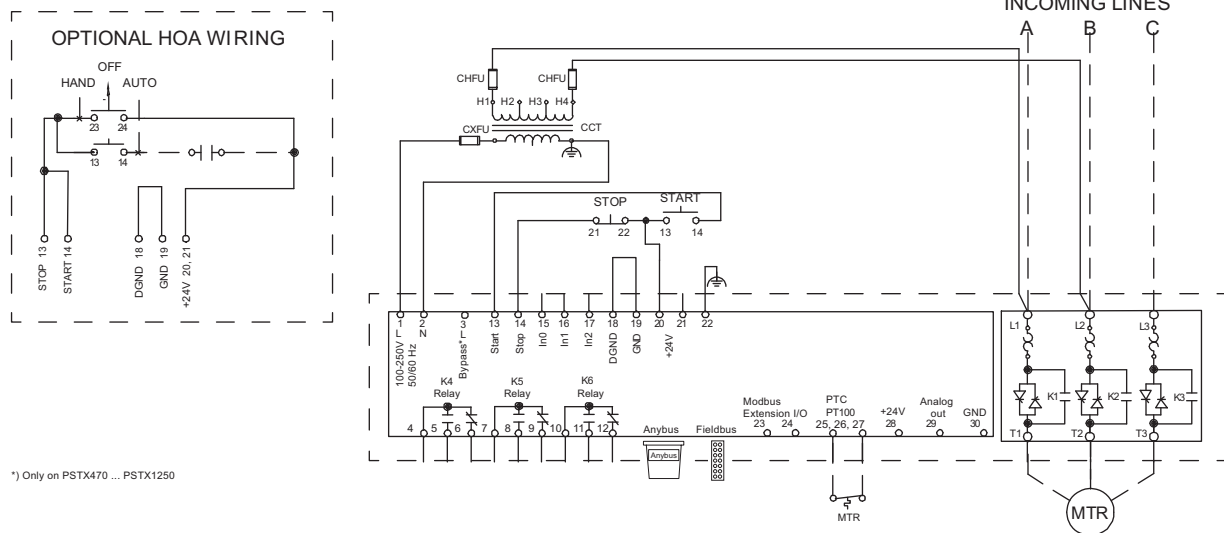
Terminal 22 is a function ground, it is not a protection ground. It shall be connected to the mounting plate.



\*) Only on PSTX470 ... PSTX1250

11

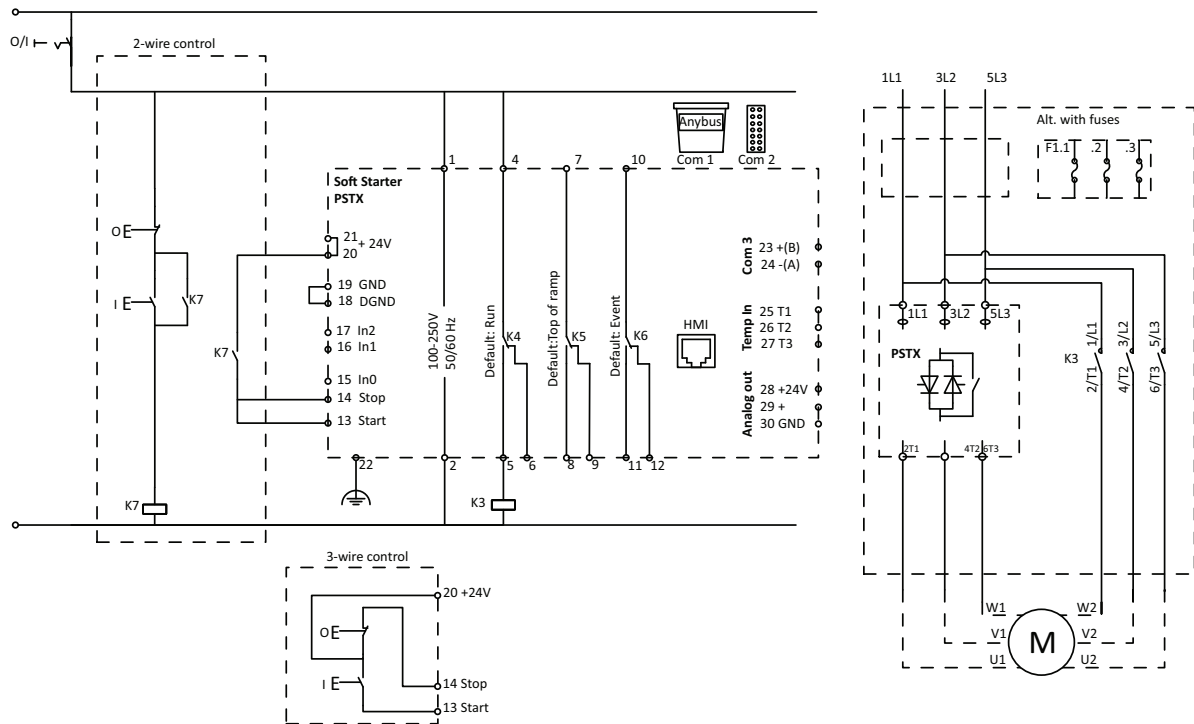
### 11.1.2 Circuit diagram PSTX30...PSTX1250 (UL version)



\*) Only on PSTX470 ... PSTX1250

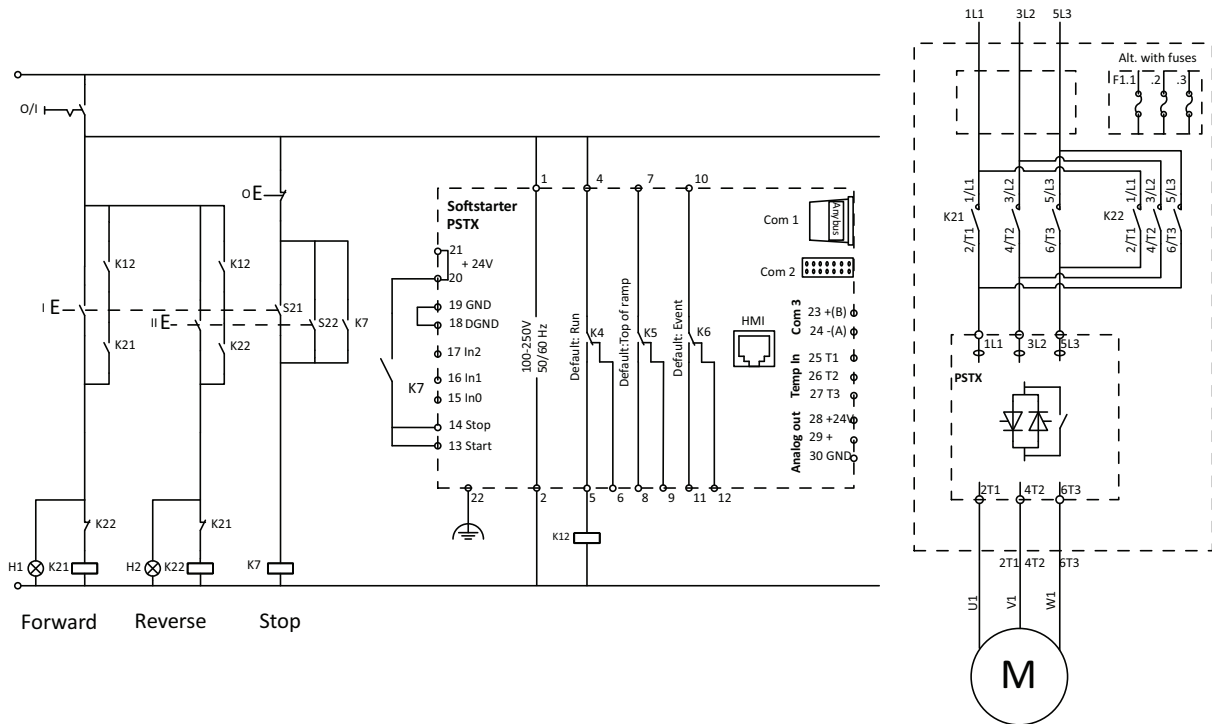
## 11.2 Application diagrams

### 11.2.1 Inside Delta



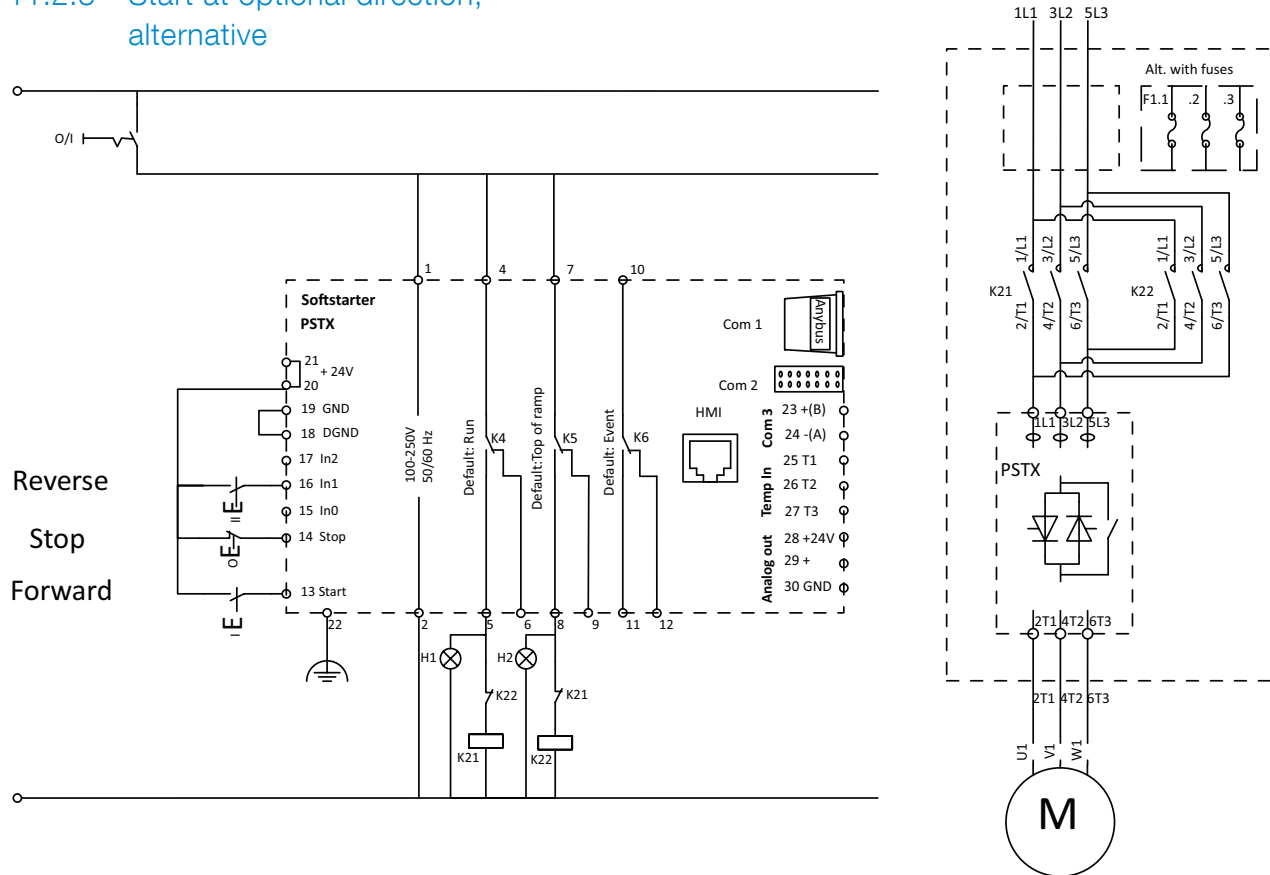
Inside Delta can be used with a lower rated Softstarter than for Inline. Parameter 01.01 Motor rated current  $I_e = 58\%$  of the Motor rated current listed in the Motor number plate. Coil consumption for Inside Delta contactor, Pull-in max 15A, Holding max 1.5 A. If the pull-in or holding values are higher, the Inside Delta contactor must be controlled via an auxiliary contactor.

### 11.2.2 Start at optional direction



Start at optional direction must be used to achieve the ability to run the motor at full speed both forward and reverse. Before changing direction, motor must be stopped.

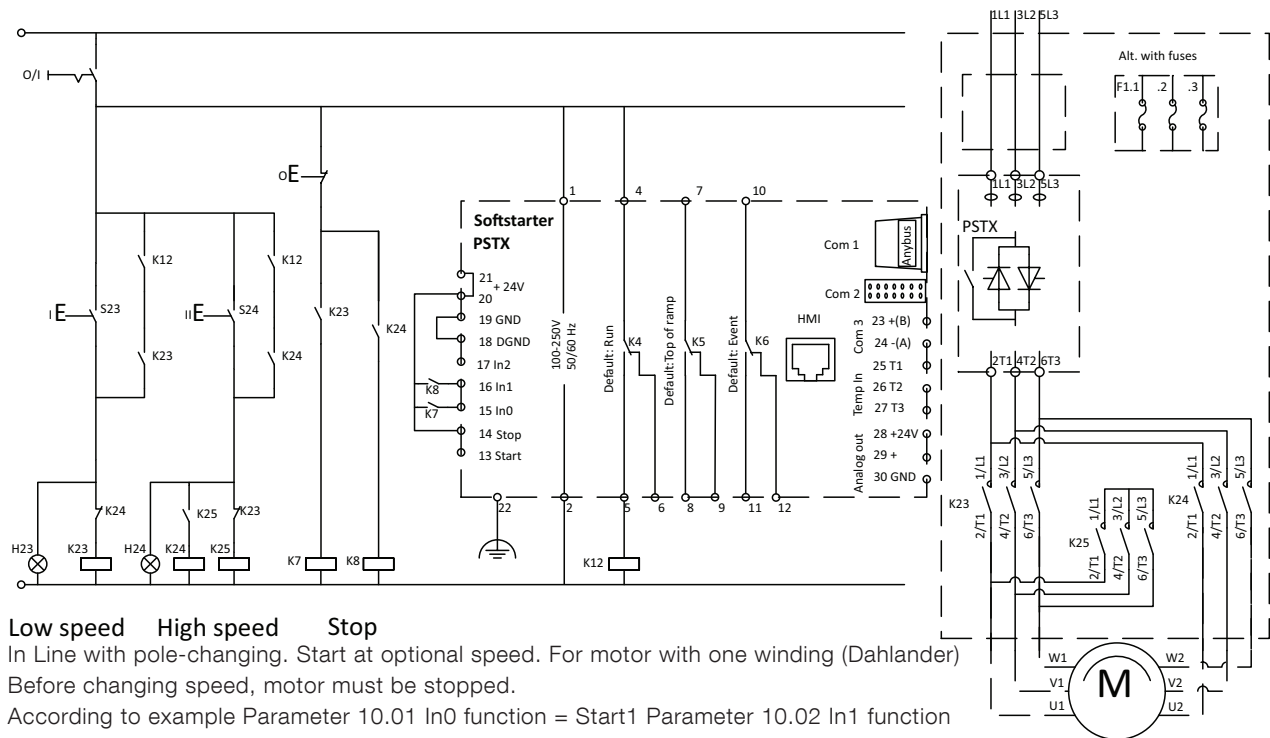
### 11.2.3 Start at optional direction, alternative



Alternative In Line with reversing, less external connections. Before changing direction, motor must be stopped.  
According to example Parameter 10.02 In1 function = Start reverse Parameter 10.05 K5 function = Run reverse

### 11.2.4 With pole change, one winding motor

11



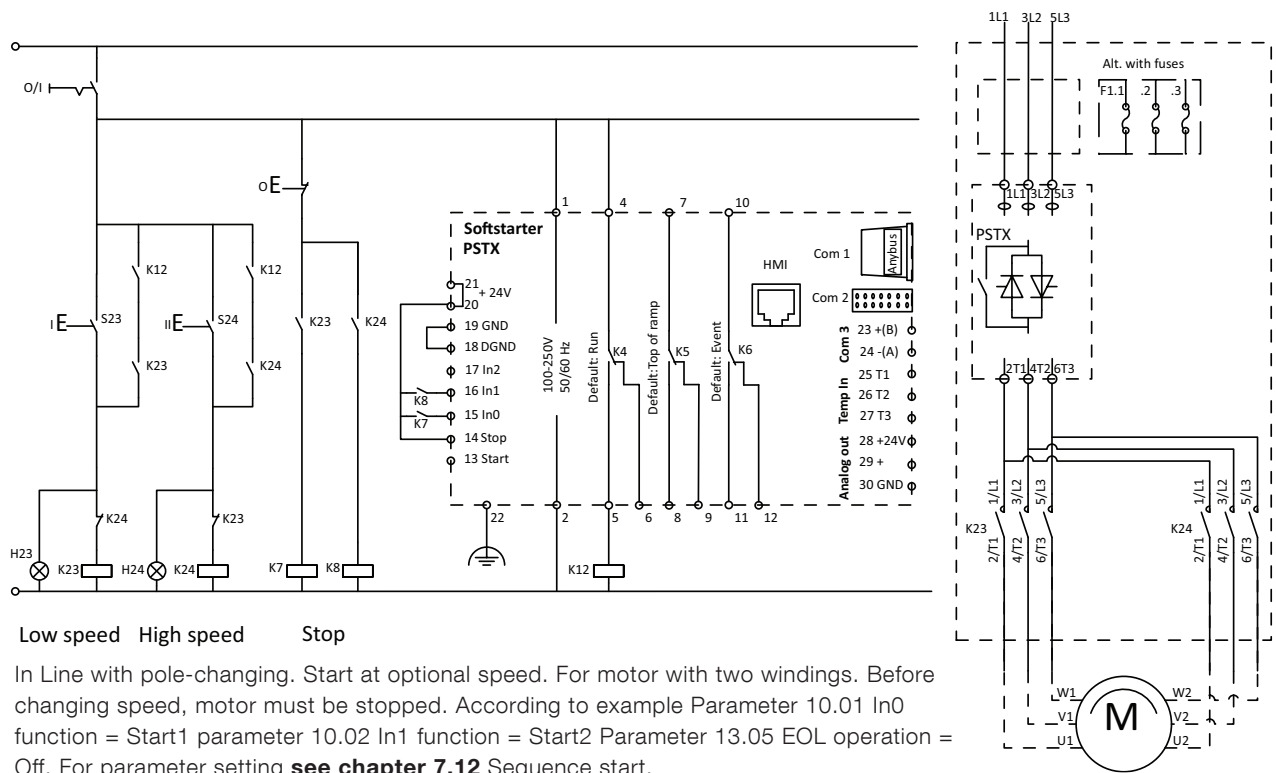
Low speed High speed Stop

In Line with pole-changing. Start at optional speed. For motor with one winding (Dahlander) Before changing speed, motor must be stopped.

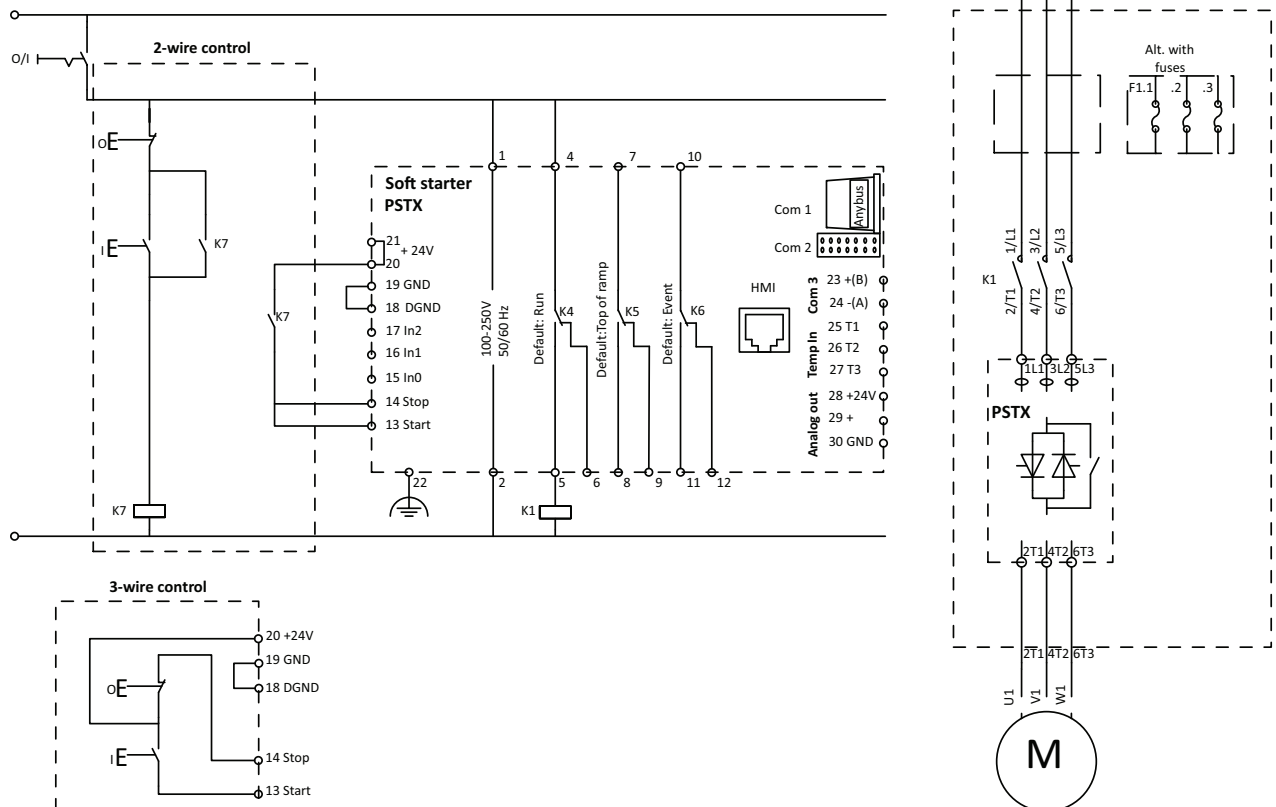
According to example Parameter 10.01 In0 function = Start1 Parameter 10.02 In1 function = Start2 Parameter 13.05 EOL operation = Off. For parameter setting **see chapter 7.12** Sequence start.



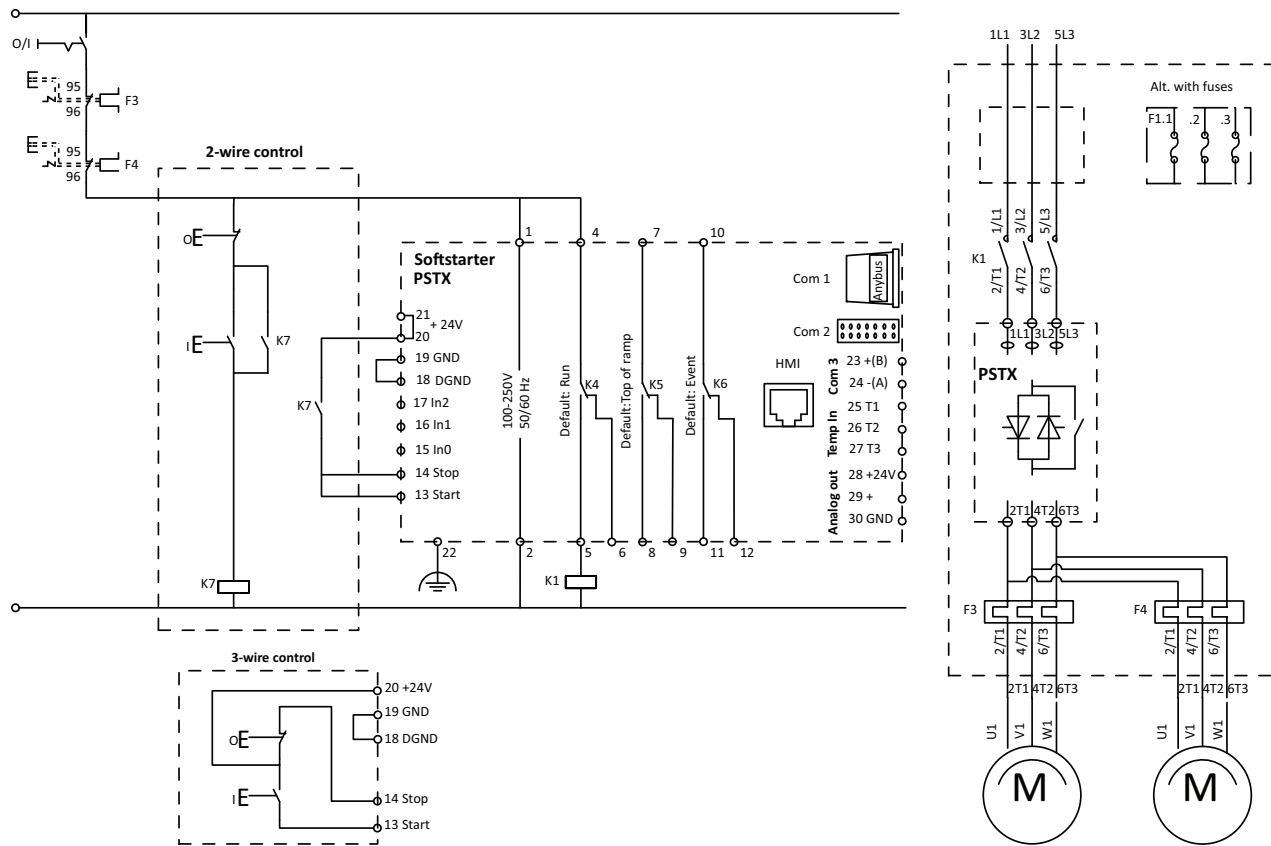
## 11.2.5 With pole change, two winding motor



## 11.2.6 InLine contactor control



## 11.2.7 Dual motor start

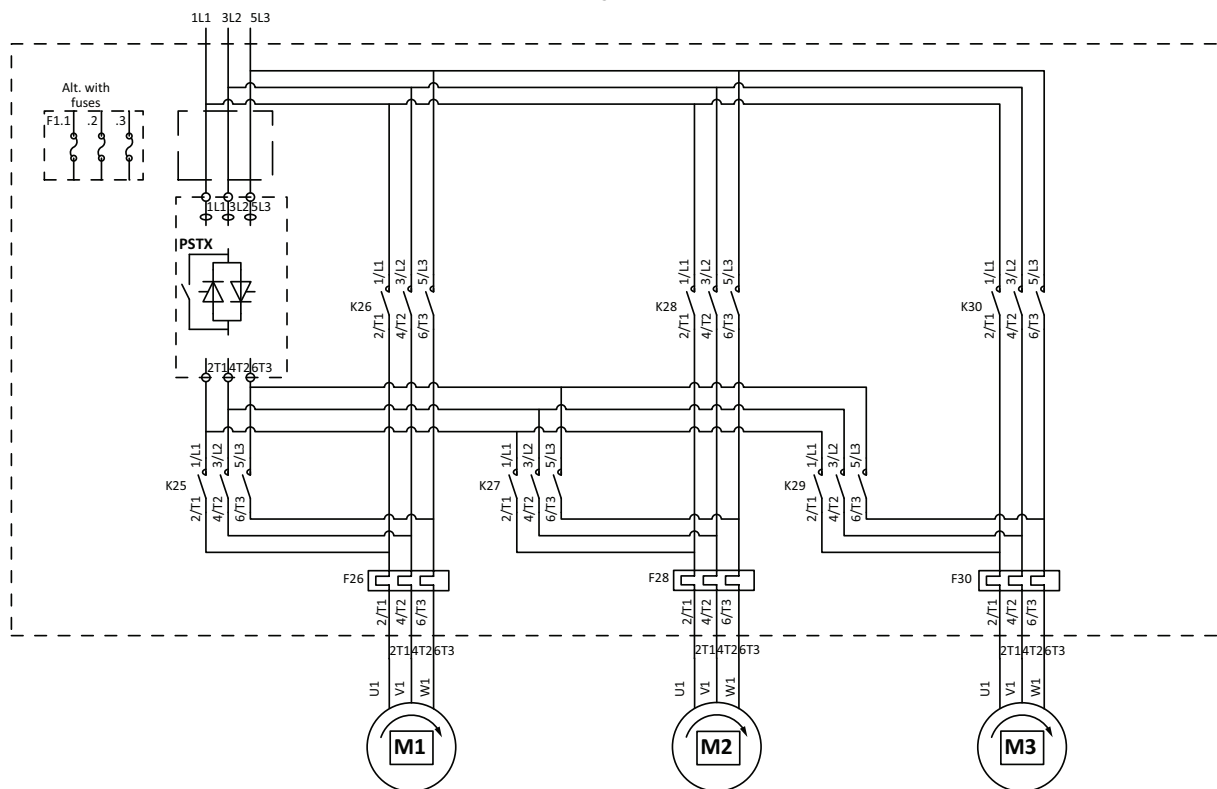
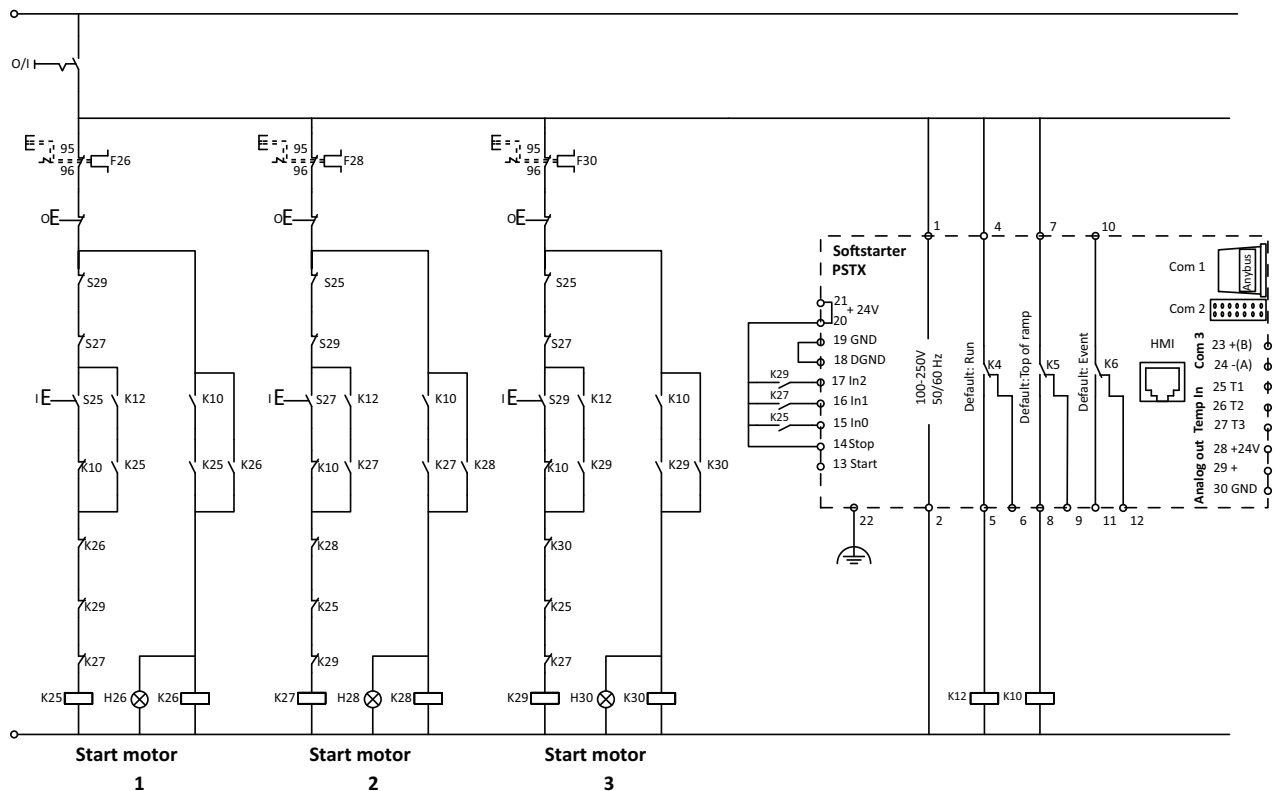


In Line with main contactor for start of 2 motors in parallell. Internal EOL shall be deactivated.

Parameter 13.05 EOL operation = Off

Coil consumption for main contactors, Pull-in max 15A, Holding max 1.5 A. If the pull-in or holding values are higher, the main contactors must be controlled via an auxillary contactor.

## 11.2.8 Sequence start



In Line for sequential start of 3 motors, no soft stop.

Internal EOL shall be deactivated. 13.05 EOL operation = Off

Start of optional motor. According to example 10.01 In0 function = Start1. 10.02 In1 function = Start2. 10.03 In2 function = Start3 For parameter settings see chapter 7.12 Sequence start.

### 11.2.9 Softstarter in network with high harmonic disturbances

When using a softstarter in a network with high harmonic disturbances, there is a risk to damage the softstarter. An example could be installations where VSDs (variable speed drives) are connected to the same transformer as the softstarter.

The harmonics are only harmful for the softstarter when it's not running the motor. To avoid problems with harmonics, either reduce the harmonics with filters on the line side, or install a line contactor to switch off the line side when the softstarter isn't running the motor.

# 12 Third party licenses

The 3rd party software components in the following sections are all part of the PSTX HMI firmware.

## 12.1 Pawn AMX Abstract Machine Wrapper

12.1 Pawn AMX Abstract Machine Wrapper	172
12.2 Zlib	174

## 12.1 Pawn AMX Abstract Machine Wrapper

PSTX HMI use the Pawn AMX Abstract Machine Wrapper as is. The software is licensed under the Apache license Version 2.0.

### Apache License Version 2.0, January 2004

<http://www.apache.org/licenses/>

TERMS AND CONDITIONS FOR USE, REPRODUCTION,  
AND DISTRIBUTION

#### 1. Definitions

“License” shall mean the terms and conditions for use, reproduction, and distribution as defined by Sections 1 through 9 of this document.

“Licensor” shall mean the copyright owner or entity authorized by the copyright owner that is granting the License.

“Legal Entity” shall mean the union of the acting entity and all other entities that control, are controlled by, or are under common control with that entity. For the purposes of this definition, “control” means (i) the power, direct or indirect, to cause the direction or management of such entity, whether by contract or otherwise, or (ii) ownership of fifty percent (50%) or more of the outstanding shares, or (iii) beneficial ownership of such entity.

“You” (or “Your”) shall mean an individual or Legal Entity exercising permissions granted by this License.

“Source” form shall mean the preferred form for making modifications, including but not limited to software source code, documentation source, and configuration files.

“Object” form shall mean any form resulting from mechanical transformation or translation of a Source form, including but not limited to compiled object code, generated documentation, and conversions to other media types.

“Work” shall mean the work of authorship, whether in Source or Object form, made available under the License, as indicated by a copyright notice that is included in or attached to the work (an example is provided in the Appendix below).

“Derivative Works” shall mean any work, whether in Source or Object form, that is based on (or derived from) the Work and for which the editorial revisions, annotations, elaborations, or other modifications represent, as a whole, an original work of authorship. For the purposes of this License, Derivative Works shall not include works that remain separable from, or merely link (or bind by name) to the interfaces of, the Work and Derivative Works thereof.

“Contribution” shall mean any work of authorship, including the original version of the Work and any modifications or additions to that Work or Derivative Works thereof, that is intentionally submitted to Licensor for inclusion in the Work by the copyright owner or by an individual or Legal Entity authorized to submit on behalf of the copyright owner. For the purposes of this definition, “submitted” means any form of electronic, verbal, or written communication sent to the Licensor or its representatives, including but not limited to communication on electronic mailing lists, source code control systems, and issue tracking systems that are managed by, or on behalf of, the Licensor for the purpose of discussing and improving the Work, but excluding communication that is conspicuously marked or otherwise designated in writing by the copyright owner as “Not a Contribution.”

“Contributor” shall mean Licensor and any individual or Legal Entity on behalf of whom a Contribution has been received by Licensor and subsequently incorporated within the Work.

#### 2. Grant of Copyright License

Subject to the terms and conditions of this License, each Contributor hereby grants to You a perpetual, worldwide, non-exclusive, no-charge, royalty-free, irrevocable copyright license to reproduce, prepare Derivative Works of, publicly display, publicly perform, sublicense, and distribute the Work and such Derivative Works in Source or Object form.

### 3. Grant of Patent License

Subject to the terms and conditions of this License, each Contributor hereby grants to You a perpetual, worldwide, non-exclusive, no-charge, royalty-free, irrevocable (except as stated in this section) patent license to make, have made, use, offer to sell, sell, import, and otherwise transfer the Work, where such license applies only to those patent claims licensable by such Contributor that are necessarily infringed by their Contribution(s) alone or by combination of their Contribution(s) with the Work to which such Contribution(s) was submitted. If You institute patent litigation against any entity (including a cross-claim or counterclaim in a lawsuit) alleging that the Work or a Contribution incorporated within the Work constitutes direct or contributory patent infringement, then any patent licenses granted to You under this License for that Work shall terminate as of the date such litigation is filed.

### 4. Redistribution

You may reproduce and distribute copies of the Work or Derivative Works thereof in any medium, with or without modifications, and in Source or Object form, provided that You meet the following conditions:

- a. You must give any other recipients of the Work or Derivative Works a copy of this License; and
- b. You must cause any modified files to carry prominent notices stating that You changed the files; and
- c. You must retain, in the Source form of any Derivative Works that You distribute, all copyright, patent, trademark, and attribution notices from the Source form of the Work, excluding those notices that do not pertain to any part of the Derivative Works; and
- d. If the Work includes a "NOTICE" text file as part of its distribution, then any Derivative Works that You distribute must include a readable copy of the attribution notices contained within such NOTICE file, excluding those notices that do not pertain to any part of the Derivative Works, in at least one of the following places: within a NOTICE text file distributed as part of the Derivative Works; within the Source form or documentation, if provided along with the Derivative Works; or, within a display generated by the Derivative Works, if and wherever such third-party notices normally appear. The contents of the NOTICE file are for informational purposes only and do not modify the License. You may add Your own attribution notices within Derivative Works that You distribute, alongside or as an addendum to the NOTICE text from the Work, provided that such additional attribution notices cannot be construed as modifying the License.

You may add Your own copyright statement to Your modifications and may provide additional or different license terms and conditions for use, reproduction, or distribution of Your modifications, or for any such Derivative Works as a whole, provided Your use, reproduction, and distribution of the Work otherwise complies with the conditions stated in this License.

### 5. Submission of Contributions

Unless You explicitly state otherwise, any Contribution intentionally submitted for inclusion in the Work by You to the Licensor shall be under the terms and conditions of this License, without any additional terms or conditions. Notwithstanding the above, nothing herein shall supersede or modify the terms of any separate license agreement you may have executed with Licensor regarding such Contributions.

### 6. Trademarks

This License does not grant permission to use the trade names, trademarks, service marks, or product names of the Licensor, except as required for reasonable and customary use in describing the origin of the Work and reproducing the content of the NOTICE file.

### 7. Disclaimer of Warranty.

Unless required by applicable law or agreed to in writing, Licensor provides the Work (and each Contributor provides its Contributions) on an "AS IS" BASIS, WITHOUT WARRANTIES OR CONDITIONS OF ANY KIND, either express or implied, including, without limitation, any warranties or conditions of TITLE, NON-INFRINGEMENT, MERCHANTABILITY, or FITNESS FOR A PARTICULAR PURPOSE. You are solely responsible for determining the appropriateness of using or redistributing the Work and assume any risks associated with Your exercise of permissions under this License.

### 8. Limitation of Liability

In no event and under no legal theory, whether in tort (including negligence), contract, or otherwise, unless required by applicable law (such as deliberate and grossly negligent acts) or agreed to in writing, shall any Contributor be liable to You for damages, including any direct, indirect, special, incidental, or consequential damages of any character arising as a result of this License or out of the use or inability to use the Work (including but not limited to damages for loss of goodwill, work stoppage, computer failure or malfunction, or any and all other commercial damages or losses), even if such Contributor has been advised of the possibility of such damages.

## 9. Accepting Warranty or Additional Liability

While redistributing the Work or Derivative Works thereof, You may choose to offer, and charge a fee for, acceptance of support, warranty, indemnity, or other liability obligations and/or rights consistent with this License. However, in accepting such obligations, You may act only on Your own behalf and on Your sole responsibility, not on behalf of any other Contributor, and only if You agree to indemnify, defend, and hold each Contributor harmless for any liability incurred by, or claims asserted against, such Contributor by reason of your accepting any such warranty or additional liability.

END OF TERMS AND CONDITIONS

## 12.2 Zlib

PSTX HMI use the inflate component PUFF from the compression library zlib. The component has been adapted by ABB. The software is licensed under the zlib/libpng license.

### The zlib/libpng License

Copyright (c) 2002-2010 Mark Adler

This software is provided 'as-is', without any express or implied warranty. In no event will the authors be held liable for any damages arising from the use of this software.

Permission is granted to anyone to use this software for any purpose, including commercial applications, and to alter it and redistribute it freely, subject to the following restrictions:

1. The origin of this software must not be misrepresented; you must not claim that you wrote the original software. If you use this software in a product, an acknowledgment in the product documentation would be appreciated but is not required.
2. Altered source versions must be plainly marked as such, and must not be misrepresented as being the original software.
3. This notice may not be removed or altered from any source distribution.





# 13 Revision

The following revisions is done on this document:

Document number	Revision	Chapter	Description	Date
1SFC132081M0201	A	-	First release	2014-06-27
1SFC132081M0201	B	4-11	New numbering of images	201x-xx-xx
1SFC132081M0201	B	5 -10	Updated technical description	2014-09-19
1SFC132081M0201	C	5, 7	Text and illustration updated	2014-11-14
1SFC132081M0201	D	3, 7	Text and illustration updated	2015-06-26
1SFC132081M0201	E	-	Text and illustration updated	2015-09-30
1SFC132081M0201	F	5	Illustrations updated	2015-10-23
1SFC132081M0201	G	-	ABB Update	201x-xx-xx
1SFC132081M0201	H	-	Text and illustration updated. New chapters: 11.2	2016-07-21
1SFC132081M0201	I	7, 12	Chapter 7-20-1 edited. Chapter 12 Third party licenses added.	2016-11-28
1SFC132081M0201	J		ABB Update	2017-09-01
1SFC132081M0201	K		ABB Update	2017-09-07
1SFC132081M0201	L	1, 7-9	ABB Update	2018-07-06
1SFC132081M0201	M		ABB Update	2019-10-02
1SFC132081M0201	N	0-1, 3-11, 13-14	ABB Update	2021-07-24
1SFC132081M0201	O		ABB Update	2021-09-15
1SFC132081M0201	P		ABB Update	2022-01-17
1SFC132081M0201	Q	5,7,9	ABB Update	2022-03-31



# 14 Index

## Symboler

2-wire measurement for PT100 47  
2-wire measurement for PTC 48  
3-wire measurement for PT100 47

## A

ABB Fieldbus plug interface (option) 147  
Acronyms and abbreviations 9  
Active faults/protections and warnings 60  
Add information screens to home view 59  
Analog output 48, 95  
Anybus CompactCom 146  
Application Setting 14, 15, 65, 133  
Application set-up 15, 65  
Assistants 65, 132

- Application set-up 65
- Basic set-up 65

Automatic restart 90  
Available protections 18. Se även Protections  
Available warnings 19. Se även Warnings

## B

Backup handling 67

- Create backup 67, 152, 153, 154, 155
- Replace backup 67
- Uploading of parameters 67

Bad network fault 122  
Basic set-up 14, 65  
Bi-metal switch 108  
Built in modbus RTU 146  
Bypass 18  
Bypass open protection 107

## C

Changing the Rated motor current  
(Setting Ie). 55  
Communication 145  
Communication protocols 22  
Complete list 62  
Complete parameter list 135  
Configuration 14  
Connection 12  
Connection fault 123  
control circuit 9  
Control supply and control circuit 40  
Control supply voltage 9  
Control supply voltage - terminals 1 and 2 40  
cooling 33  
Cooling system 22  
Create backup 67, 152, 153, 154, 155  
current 9  
Current imbalance protection 105  
Current imbalance warning 115  
Current Lim

- Dual current limit 83
- Ramp current limit 83

Current limit 83

- Normal current limit 83, 87

Current underload protection 104  
Current underload warning 115

## D

Date and time 70  
Delivery note 32  
Description 17  
Detachable keypad 34  
Dimensions and drilling plan 34  
Direct stop 81  
Display decimals 60  
Display name 60  
Display settings 70  
Display slot 59  
Display style 60  
Document number 2  
Drilling plan 34  
Dual current limit 83

## E

Earth fault protection 110  
Edit home view 59  
Edit information screens in home view 59  
Edit parameter values 54  
Electrical connection 38  
Electronic overload protection 103  
Electronic overload time-to-trip warning 117  
Electronic overload warning 114  
Electronics failure 122  
Emergency mode 124  
Environmental influence 21  
EOL 9  
Error caused by the line 108  
Event groups 101  
Event log

- Faults 66
- Parameter changed 66
- Protections 66
- Run 66
- Warnings 66

Extension I/O failure protection 112  
Extension IO (Option) 91  
External control voltage 42  
External fault 119  
External faults 122  
External thermal sensor - PT100 protection 109  
External thermal sensor - PTC protection 108

## F

Fault 22  
Fault detection functions 19  
Faults 66, 119

- External fault 119
- Internal fault 119

Faults indication 164  
Faulty usage fault 123  
Favorites 64  
Fieldbus 97

- Fieldbus address 97

- Fieldbus control 97
- Fieldbus Inputs/Outputs 98

Fieldbus control 97  
 Fieldbus failure operation 97. Se även Fieldbus failure protection  
 Fieldbus failure protection 112  
 Fieldbus Inputs/Outputs 98  
 Frequency range protection 107  
 Full voltage 9  
 Full voltage start 81  
 Functional earth - terminal 22 40  
 Functions 73

## H

Handling when mounting 33  
 Heat sink over temperature fault 121  
 High current fault 123  
 HMI 9  
 How to set a parameter 55  
 How to start/stop the motor 15  
 Human-Machine Interface 9  
 Humidity 21

## I

le 9  
 i-key 53  
 Individual function 74  
 Inputs/outputs 91
 

- Analog output 95
- Relay outputs 94
- Temperature sensor 96

 Insulation 22  
 Internal fault 119
 

- Internal fault 119

 Internal faults 120  
 Internal IO 91  
 IO controller protection 113

## K

Keypad
 

- i-key 53
- Navigation keys 53
- R/L-key 53
- Start key 53
- Stop key 53

 Kick start 84

## L

Language 69  
 LED 9  
 LED indicators 52  
 LED status 52  
 Limp mode 125  
 Line contactor close time 125  
 Local control from keypad 57
 

- R/L-key 57
- Start key 57
- Stop key 57

 Locked rotor protection 103  
 Locked rotor warning 114  
 Low supply voltage fault 123

## M

Maintenance 149  
 Maximum mounting angle 34  
 Max number of starts protection 103  
 Menu screen 62
 

- Favorites 64
- Modified 64
- Parameters 62

 Minimum distance to wall/fron 33  
 Minimum enclosure size 34  
 MINI USB interface 147  
 Motor Current le 75  
 Motor heating 86, 87  
 Motor jog 58  
 Mount 33  
 Mounting Detachable HMI 35

## N

Navigation keys 53  
 Navigation Overview 52  
 Normal current limit 83, 87

## O

On/off switch 54  
 Open circuit thyristor fault 121  
 Optional accessories 49  
 Options screen 59  
 Output relay 22  
 Overview 18  
 Overview of faults, protections and warnings 161  
 Overvoltage protection 105  
 Overvoltage warning 116

## P

Parameter changed 66  
 Parameters 62
 

- Complete list 62

 Parameter storage warning 118  
 Phase loss fault 122  
 Phase reversal protection 106  
 PLC 9  
 Pollution degree 21  
 Power factor underload protection 104  
 Power factor underload warning 115  
 Presentation settings 68  
 Pre-start 74  
 Programmable inputs (Sequence start) 44  
 Programmable inputs - terminals 15, 16 and 17 43  
 Programmable output relay - K4, terminals 4, 5 and 6 45  
 Programmable output relay - K5, terminals 7, 8 and 9 45  
 Programmable output relay - K6, terminals 10, 11 and 12 45  
 Protection 21  
 Protection functions 18  
 Protection indication 163, 167  
 Protection indication shown on screen 163  
 Protections 66, 102  
 PT100 108  
 PTC 96  
 PTC/PT100 input 47

## Q

Quick start 11

## R

Ramp current limit 83

Real time clock 70

Receive, unpack and check 32

Relay outputs 94

Replace backup 67

Reset operating data 71

Reset to defaults 71

R\L-key 53, 57

Run 66

## S

Scale value range 60

Selection list 54

Selection softkeys 53

Semi-conductor fuses 22

Sequence start 89

Service and repair 151, 152

Settings 68, 128

- Date and time 70
- Display settings 70
- Language 69
- Reset to defaults 71

Short circuit fault 120

Short circuit warning 117

Signal 59

Signal max 60

Signal min 60

Slow speed 85

Softstarter overview 20

Softstarter ratings 23

Softstarter states 74

- Individual function 74
- Pre-start 74
- Stand by 74
- Start ramp 75
- Stop ramp 75
- Top of ramp 75

Special feature 124

- Emergency mode 124
- Limp mode 125
- Line contactor close time 125
- Start without start command 125
- Step down level 126
- System mode 126
- TOR relay delay time 127

Specifications 21

Stand by 74

Stand still brake 82

Start and Stop - terminals 13, 14, 18, 19, 20, 21 41

Start key 53, 57

Start ramp 75

Start without start command 125

Step down level 126

Stop key 53, 57

Stop ramp 75

Storage 21, 22

System info 68

System mode 126

## T

Table Application settings 134

Technical data 22

Technical data for external keypad 22

Temperature 9, 21, 22

Temperature errors in °C / K 109

Temperature sensor 96

- External thermal sensor - PT100 protection 109
- External thermal sensor - PTC protection 108
- PT100 108
- PTC 96
- Thermistor switch 108

Temperature sensors 108

The numerical setting 54

Thyristor 9

Thyristor overload fault 121

Thyristor overload warning 115

Too long current limit protection 110

Top level 57

Top of ramp 75

Shunt fault TOR 9

Torque ramp 78

- Torque stop ramp 80

Torque start ramp 79

Torque stop ramp 80

TOR relay delay time 127

Total Harmonic Distortion warning 117

Troubleshooting 157

- Overview of faults, protections and warnings 161
- Protection indication shown on screen 163

Type designation 21

## U

Uc 9

Ue 9

Undervoltage protection 105

Undervoltage warning 116

Unspecified fault 122

Uploading of parameters 67

Us 9

User defined protection 19

User interface 18

## V

Voltage imbalance warning 116

Voltage outputs protection 107

Voltage ramp 76

- Voltage start ramp 76
- Voltage stop ramp 77

Voltage sag detection 127

Voltage start ramp 76

Voltage stop ramp 77

## W

Warning functions 19

Warnings 66, 114

Weights 22



---

**ABB Electrification Sweden AB**  
**Smart Power - Motor Starting & Safety**  
SE-721 61 Västerås  
Sweden  
E-mail: sales@se.abb.com

<https://solutions.abb/softstarters>





SOFTSTARTER TYPE PSTX

# Fieldbus communication

## Built-in Modbus RTU



PREPARED 2021-03-12	STATUS Approved	SECURITY LEVEL Public		
RELEASED 2021-05-03	DOCUMENT KIND Manual			
OWNING ORGANIZATION Motor Starting & Safety Softstarters	DOCUMENT ID. 1SFC132089M0201	REV. F	LANG. en	PAGE 1/36
© Copyright 2021 ABB. All rights reserved.				

# Contents

- 1. Modbus RTU ..... 3**
- 2. Modbus Addressing ..... 4**
  - 2.1. Protocol Address ..... 4
  - 2.2. Modicon Address ..... 4
  - 2.3. Translating Modicon address to protocol address ..... 5
- 3. PSTX Data ..... 5**
  - 3.1. Digital input telegram ..... 5
  - 3.2. Programmable Digital Inputs ..... 6
  - 3.3. Analog input telegram ..... 8
  - 3.4. Status word ..... 8
  - 3.5. Programmable Analog Inputs ..... 9
  - 3.6. Digital output telegram ..... 11
  - 3.7. Analog output telegram ..... 12
  - 3.8. Control words ..... 13
- 4. Modbus RTU - A set-up example ..... 14**
  - 4.1. Softstarter PSTX Modbus RTU communication ..... 14
  - 4.2. Settings ..... 14
  - 4.3. Read digital input telegram ..... 16
  - 4.4. Write digital output telegram ..... 17
  - 4.5. Read analog input telegram ..... 18
  - 4.6. Write analog output telegram ..... 19
- 5. Fieldbus Tasks ..... 20**
  - 5.1. FBT Control Word ..... 20
  - 5.2. Task ID ..... 20
  - 5.3. Response ID ..... 20
  - 5.4. Error codes ..... 21
  - 5.5. Request parameter value, lower word ..... 21
    - 5.5.1. Arguments ..... 21
    - 5.5.2. Return Value ..... 21
  - 5.6. Change parameter value ..... 21
    - 5.6.1. Arguments ..... 21
    - 5.6.2. Return Value ..... 21
  - 5.7. Set date and time ..... 22
    - 5.7.1. Arguments ..... 22
    - 5.7.2. Return Value ..... 22
  - 5.8. Request parameter value, upper word ..... 22
    - 5.8.1. Arguments ..... 22
    - 5.8.2. Return Value ..... 22
  - 5.9. Parameter numbers and values ..... 23
    - 5.9.1. Negative values ..... 23
- 6. Troubleshooting ..... 24**
- 7. Example application with Automation Builder ..... 24**
  - 7.1. Create a new project in Automation Builder ..... 24
  - 7.2. Add Modbus RTU master to project ..... 26
  - 7.3. Build a START-STOP program ..... 27
  - 7.4. Connect to PLC using TCP/IP ..... 34
  - 7.5. Build and run the PLC demo program ..... 36
- 8. Contact us ..... 36**

# 1. Modbus RTU

Modbus is a master-slave protocol and only one device can transmit on the line at any time. The master (which in most cases is a PLC) manages the exchanges and only it can take the initiative. It interrogates each of the slaves in succession and no slave can send a message unless it is invited to do so. The master repeats the question when there is an incorrect exchange and declares the interrogated slave absent if no response is received within a given time. If a slave does not understand a message, it sends an exception response to the master who may or may not repeat the request.

The Modbus protocol is a fieldbus protocol that provides full control and status information of the softstarter, reading as well as writing of parameters. Through the fieldbus it is possible to start and stop the motor, read out currents and frequency, get information about protections, warnings, faults and much more.

See chapter 8 in the Installation and commissioning manual, document 1SFC132081M0201, for fieldbus related settings.

Before the Modbus RTU can be taken in operation following parameters must be set in the softstarter:

- Parameter 12.2 FB interface connector set to Modbus RTU.
- Parameter 12.3 Fieldbus control set to On (This parameter can be set to Off if the fieldbus interface is only used to monitor the softstarter)
- Parameter 12.9 FB baud rate set to a value matching existing Modbus network (supported baud rates are 9600, 19200, 38400, 57600, 76800 and 115200 Baud).
- Parameter 12.10 FB parity set to a value matching existing Modbus network.
- Parameter 12.11 FB stop bits set to a value matching existing Modbus network.
- Parameter 12.4 Fieldbus address set to an available Modbus slave id. In the examples (section 4) the fieldbus address is set to 47, but this parameter can be set to any value between 1-247.
- Parameter 12.1 Com3 function set to Modbus RTU slave.



### Information

After changing any of the communication parameters it is needed to perform a power cycle of the device for the parameter values to be taken into effect. Or another way for a communication parameter value change to be taken into effect is to set parameter 12.2 FB interface connector to “None” and then set it back to “Modbus RTU”.

If there is no message passed between the PSTX softstarter and the Modbus master for more than the configured fieldbus failure timeout time (parameter 19.12), the PSTX softstarter will trip on fieldbus communication failure protection (P1E00) and with the default configuration the motor will be stopped. If the communication system is setup in such a way that commands/requests are not continuously passed between the PLC and softstarter, this protection function should be disabled. The parameter 19.4 (Fieldbus failure op) can then be set to “Off”.

STATUS	SECURITY LEVEL	DOCUMENT ID.	REV.	LANG.	PAGE
Approved	Public	1SFC132089M0201	F	en	3/36

**Information**

The DX111 or DX112 expansion IO module shares the same terminals (23 and 24) as the internal Modbus RTU communication, so both cannot be used at the same time.

**Caution!**

The motor may start unexpectedly if there is a start signal present when doing any of the actions listed below.

- Switching from one type of control to another (fieldbus control/hardwire control)
- Reset all Settings

## 2. Modbus Addressing

When talking about Modbus addressing, there is often a misunderstanding about what an address really is. This section will try to clarify the conventions in this document.

### 2.1. Protocol Address

The Modbus standard specification uses one kind of address, a two-byte unsigned integer (0-65535).

This is the address that is actually transmitted to the device.

### 2.2. Modicon Address

Modbus was originally developed by Modicon and the notation used then is still often used today, though considered obsolete by present standards.

The Modicon notation combines two pieces of information in a single number:

1. The register type
2. The register number

A register number offset defines the type and makes it possible to translate between the two types of addresses.

**Table 1 Register types and ranges**

Prefix	Register Type	Range
0x	Coil	00001-00001
1x	Discrete Input	10001-19999
3x	Input Register	30001-39999
4x	Holding Register	40001-49999

## 2.3. Translating Modicon address to protocol address

**An example:**

Modicon address 40002 selects the holding register at protocol address 0001 (40002 – 40001 = 1). The protocol address 0001 will be transmitted in the message packet.

# 3. PSTX Data

## 3.1. Digital input telegram

To PLC from the softstarter. The input data is updated every 20 ms.

Use Modbus function code 01, Read Coil Status.

Protocol Address	Modicon Address	Data	Description
0000h	00001	Auto Mode status <sup>1</sup>	0 = Softstarter control through Modbus disabled 1 = Softstarter control through Modbus enabled
0001h	00002	Event status	0 = No active fault/warning/protection 1 = Active fault/warning/protection
0002h	00003	Ready to start	0 = A start will probably cause a fault, 1 = A start will probably not cause a fault
0003h	00004	FBT Response 0	See Fieldbus Tasks
0004h	00005	FBT Response 1	See Fieldbus Tasks
0005h	00006	FBT Toggle Bit	See Fieldbus Tasks
0006h	00007	Programmable Digital Input 1	Function of programmable digital input, see section 3.2
0007h	00008	Programmable Digital Input 2	
0008h	00009	Programmable Digital Input 3	
0009h	00010	Programmable Digital Input 4	
000Ah	00011	Programmable Digital Input 5	
000Bh	00012	Programmable Digital Input 6	
000Ch	00013	Programmable Digital Input 7	
000Dh	00014	Programmable Digital Input 8	
000Eh	00015	Programmable Digital Input 9	
000Fh	00016	Programmable Digital Input 10	

<sup>1)</sup> Auto mode reflects the control state of the Softstarter. This is affected by a combination of:

- The Auto mode input signal from the PLC (protocol address 0000h in the digital output telegram or bit 3 in the control word).
- The state of the Local/Remote switch on the HMI.

- The parameter “Fieldbus control”.
- The digital input “Fieldbus disable”.

Digital input telegram is also available as a status word on protocol address 01FFh (see section 3.4).

### 3.2. Programmable Digital Inputs

The functions of the programmable Digital inputs are controlled by the parameters `Fieldbus DI 1` through `Fieldbus DI 10`. The following functions are available for selection:

Function	Data
None	Value is set to 0.
Start feedback	Status of Start signal.
Stop feedback	Status of Stop signal.
Fault reset feedback	Status of Reset signal.
Slow speed reverse feedback	Status of Slow speed reverse signal.
Slow speed forward feedback	Status of Slow speed forward signal.
Start 1 feedback	Status of Start 1 signal.
Start 2 feedback	Status of Start 2 signal.
Start 3 feedback	Status of Start 3 signal.
Motor heating feedback	Status Motor heating signal.
User defined feedback	Status of User defined protection signal.
Stand still brake feedback	Status of Stand still brake signal.
Emergency mode feedback	Status of Emergency mode signal.
Start reverse feedback	Status of Start reverse signal.
Run status	1 = Indicates when the softstarter gives voltage to the motor.
TOR status	Top of Ramp. 1 = Indicates that motor runs on full voltage.
Line	Line or Inside Delta Connection; 0 = Line, 1 = Delta.
Phase sequence	0 = L1, L2, L3; 1 = L1, L3, L2.
Event group 0 status	0 = No active events present in group 0.
Event group 1 status	0 = No active events present in group 1.
Event group 2 status	0 = No active events present in group 2.
Event group 3 status	0 = No active events present in group 3.
Event group 4 status	0 = No active events present in group 4.
Event group 5 status	0 = No active events present in group 5.
Event group 6 status	0 = No active events present in group 6.
Sequence 1 Run status	Run status of sequence connected motor 1.
Sequence 2 Run status	Run status of sequence connected motor 2.
Sequence 3 Run status	Run status of sequence connected motor 3.
Sequence 1 TOR status	Top of Ramp status of sequence connected motor 1.
Sequence 2 TOR status	Top of Ramp status of sequence connected motor 2.

Function	Data
Sequence 3 TOR status	Top of Ramp status of sequence connected motor 3.
Run reverse status	1 = Indicates when the softstarter gives voltage to the motor after a reverse start.
Enable status	Status of Enable signal.
Digital In0 status	Status of internal digital input In0.
Digital In1 status	Status of internal digital input In1.
Digital In2 status	Status of internal digital input In2.
Local control status	0 = Remote control, 1 = Local control (HMI).
Cancel brake feedback	Status of Cancel brake signal.
Pump cleaning auto status	Status of automatic pump cleaning.
Pump cleaning forward status	Status of forward pump cleaning.
Pump cleaning backward status	Status of reverse pump cleaning.
External digital 1DI0 status	Status of external digital input 1DI0 (not supported when using internal Modbus RTU).
External digital 1DI1 status	Status of external digital input 1DI1 (not supported when using internal Modbus RTU).
External digital 1DI2 status	Status of external digital input 1DI2 (not supported when using internal Modbus RTU).
External digital 1DI3 status	Status of external digital input 1DI3 (not supported when using internal Modbus RTU).
External digital 1DI4 status	Status of external digital input 1DI4 (not supported when using internal Modbus RTU).
External digital 2DI5 status	Status of external digital input 2DI5 (not supported when using internal Modbus RTU).
External digital 2DI6 status	Status of external digital input 2DI6 (not supported when using internal Modbus RTU).
External digital 2DI7 status	Status of external digital input 2DI7 (not supported when using internal Modbus RTU).
HW DI Start status	Status of the hard wire internal digital input Start.
HW DI Stop status	Status of the hard wire internal digital input Stop.
Ready to start (line contactor)	Same conditions as the Ready To Start bit except that the incoming three phase voltage condition is excluded. The bit can be used when a line contactor is connected.

### 3.3. Analog input telegram

To PLC from the softstarter.

All analog data values are represented as 16-bit values. The input data is updated every 20 ms.

Use Modbus function code 3 Read Holding Registers or function code 04, Read Input Registers.

Protocol Address	Modicon Address	Data	Representation
01FFh	30512	Status word	See section 3.4 Status word
0200h	30513	FBT Return Value	See Fieldbus Tasks
0201h	30514	Programmable Analog Input 1	Function of programmable analog input, see section 3.5
0202h	30515	Programmable Analog Input 2	
0203h	30516	Programmable Analog Input 3	
0204h	30517	Programmable Analog Input 4	
0205h	30518	Programmable Analog Input 5	
0206h	30519	Programmable Analog Input 6	
0207h	30520	Programmable Analog Input 7	
0208h	30521	Programmable Analog Input 8	
0209h	30522	Programmable Analog Input 9	
020Ah	30523	Programmable Analog Input 10	

### 3.4. Status word

The status word register is used to monitor the motor. This register can be used as an alternative to using the digital input telegram (section 3.1). Read status word using Modbus function code 3 Read Holding Registers or 4 Read Input Registers.

Protocol Address	Bit	Data	Description
01FFh	0	Auto Mode status <sup>1</sup>	0 = Softstarter control through Modbus disabled 1 = Softstarter control through Modbus enabled
	1	Event status	0 = No active fault/warning/protection 1 = Active fault/warning/protection
	2	Ready To Start	0 = A start will probably cause a fault, 1 = A start will probably not cause a fault
	3	FBT Response 0	See Fieldbus Tasks
	4	FBT Response 1	See Fieldbus Tasks
	5	FBT Toggle Bit	See Fieldbus Tasks
	6	Programmable Digital Input 1	Function of programmable digital input, see section 3.2
	7	Programmable Digital Input 2	
	8	Programmable Digital Input 3	
	9	Programmable Digital Input 4	



10	Programmable Digital Input 5
11	Programmable Digital Input 6
12	Programmable Digital Input 7
13	Programmable Digital Input 8
14	Programmable Digital Input 9
15	Programmable Digital Input 10

<sup>1)</sup> Auto mode reflects the control state of the Softstarter. This is affected by a combination of:

- The Auto mode input signal from the PLC ((protocol address 0000h in the digital output telegram or bit 3 in the control word).
- The state of the Local/Remote switch on the HMI.
- The parameter “Fieldbus control”.
- The digital input “Fieldbus disable”.

### 3.5. Programmable Analog Inputs

The functions of the programmable analog inputs are controlled by the parameters Fieldbus AI 1 through Fieldbus AI 10. The following functions are available for selection:

Function	Representation
None	Value is set to 0
Phase L1 current <sup>1</sup>	Value = 1000 ⇒ 100A
Phase L2 current <sup>1</sup>	Value = 1000 ⇒ 100A
Phase L3 current <sup>1</sup>	Value = 1000 ⇒ 100A
Active power (hp)	Value = 1000 ⇒ 10hp
Active power	Value = 1000 ⇒ 10kW
Apparent power	Value = 1000 ⇒ 10kVA
Mains voltage	Value = 1000 ⇒ 100V
Power factor	Value = 100 ⇒ 1 Example: 87 ⇒ 0.87
Motor voltage	Value = 100 ⇒ 100%
Active energy (resettable)	Value = 1000 ⇒ 10kWh
EOL time to trip	Value = 100 ⇒ 100s Value = 65535 ⇒ No overload Value = 0 ⇒ Trip already occurred
Mains frequency	Value = 1000 ⇒ 100Hz
Max phase current1	Value = 1000 ⇒ 100A
Motor current	Value = 1000 ⇒ 100A
Motor run time (resettable)	Value = 100 ⇒ 1000h
Motor temperature	Value = 100 ⇒ 100°C
Motor temperature percent	Value = 100 ⇒ 100%
Number of starts (resettable)	Value = 1 ⇒ 100

STATUS	SECURITY LEVEL	DOCUMENT ID.	REV.	LANG.	PAGE
Approved	Public	1SFC132089M0201	F	en	9/36

Function	Representation
Phase sequence	Value = 0 ⇒ L1->L2->L3 Value = 1 ⇒ L1->L3->L2 Value = 2 ⇒ No sequence detected
PT100 temperature	Value = n ⇒ n/10 – 50°C Example: 750 ⇒ 25°C
PTC resistance	Value = 100 ⇒ 100Ω
Reactive energy (resettable)	Value = 1000 ⇒ 10kVArh
Reactive power	Value = 1000 ⇒ 100VAr
Remaining time to start	Value = 100 ⇒ 100s
Thyristor temperature	Value = 100 ⇒ 100°C
Thyristor temperature percent	Value = 100 ⇒ 100%
EOL time to cool	Value = 100 ⇒ 100s
Top event code	Value = 1000 ⇒ 1000
Motor current in percent of IE.	Value = 100 ⇒ 100%
Thyristor run time (resettable)	Value = 1 ⇒ 10h
Motor connection	Value = 0 ⇒ auto Value = 1 ⇒ In-line Value = 2 ⇒ Inside delta – UI Value = 3 ⇒ Inside delta – IU Value = 4 ⇒ 2-phase L1 shorted Value = 5 ⇒ 2-phase L2 shorted Value = 6 ⇒ 2-phase L3 shorted
Phase L1 current high range <sup>2</sup>	Value = 100 ⇒ 100A
Phase L2 current high range <sup>2</sup>	Value = 100 ⇒ 100A
Phase L3 current high range <sup>2</sup>	Value = 100 ⇒ 100A
Active power (hp) high range <sup>2</sup>	Value = 100 ⇒ 100hp
Active power high range <sup>2</sup>	Value = 100 ⇒ 100kW
Apparent power high range <sup>2</sup>	Value = 100 ⇒ 100kVA
Reactive power high range <sup>2</sup>	Value = 100 ⇒ 100kVAr
Max phase current high range <sup>2</sup>	Value = 100 ⇒ 100A
Max motor current high range <sup>2</sup>	Value = 100 ⇒ 100A
Active energy high range <sup>2</sup>	Value = 1 ⇒ 10000kWh
Reactive energy high range <sup>2</sup>	Value = 1 ⇒ 10000kVArh
Number of starts (high precision)	Value = 1 ⇒ 1

<sup>1)</sup> Phase current L1, L2 and L3 indicate the current through the softstarter, while the Max phase current is always the line current.

<sup>2)</sup> High Range alternatives are available for a few signals where there is a possibility for the values to wrap. The values are 16-bit so the maximum value for each signal is 65535. The High Range alternatives have different scaling and will never wrap around but instead have lower precision.

### 3.6. Digital output telegram

From PLC to the softstarter.

Use Modbus function code 15 (0Fh), Force Multiple Coils.

Protocol Address	Modicon Address	Data	Description
0100h	257	Start	Commence a start when signal is set.
0101h	258	Stop	Commence a stop when signal is negated.
0102h	259	Fault reset	Reset signal for possible events.
0103h	260	Auto mode	This must be set for controlling the motor.
0104h	261	Slow speed reverse	Perform slow speed reverse when signal is set.
0105h	262	Slow speed forward	Perform slow speed when signal is set.
0106h	263	Spare	
0107h	264	Start1	Start1 if sequence start.
0108h	265	Start2	Start2 if sequence start.
0109h	266	Start3	Start3 if sequence start.
010Ah	267	Motor heating	Perform motor heating when signal is set.
010Bh	268	Stand still brake	Perform stand still brake when signal is set.
010Ch	269	Start reverse	Commence a reverse start when signal is set.
010Dh	270	Spare	
010Eh	271	Emergency mode	Set to "1" to enable emergency mode.
010Fh	272	FBT Toggle Bit	See Fieldbus Tasks.
0110h	273	User defined trip	Set to "1" to trigger user defined protection.
0111h	274	Switch to remote control	Switch to remote control when signal is set (rising edge triggered).
0112h	275	Pump cleaning automatic	Perform automatic pump cleaning when signal is set.
0113h	276	Pump cleaning forward	Perform forward pump cleaning when signal is set.
0114h	277	Pump cleaning reverse	Perform reverse pump cleaning when signal is set.
0115h	278	K4 relay command	Set "1" to activate the internal K4 output relay. Note that parameter 10.4 K4 function has to be set as "Fieldbus"
0116h	279	K5 relay command	Set "1" to activate the internal K5 output relay. Note that parameter 10.5 K5 function has to be set as "Fieldbus"
0117h	280	K6 relay command	Set "1" to activate the internal K6 output relay. Note that parameter 10.6 K6 function has to be set as "Fieldbus"
0118h	281	1DO0 relay command	Set "1" to activate the external 1DO0 output relay. Note that parameter 11.9 1DO0 function has to be set as "Fieldbus"

Protocol Address	Modicon Address	Data	Description
0119h	282	1DO1 relay command	Set "1" to activate the external 1DO1 output relay. Note that parameter 11.10 1DO1 function has to be set as "Fieldbus"
011Ah	283	2DO2 relay command	Set "1" to activate the external 2DO2 output relay. Note that parameter 11.11 2DO2 function has to be set as "Fieldbus"
011Bh	284	2DO3 relay command	Set "1" to activate the external 2DO3 output relay. Note that parameter 11.12 2DO3 function has to be set as "Fieldbus"
011Ch	285	Refresh parameters	Restart fieldbus interface to refresh communication parameters
011Dh	286	Spare	
011Eh	287	Spare	
011Fh	288	Spare	

Digital output telegram is also available as a control words on protocol addresses 02FEh and 02FFh (see section 3.8).

### 3.7. Analog output telegram

From PLC to the softstarter.

All analog data values are represented as 16-bit values.

Use Modbus function code 6 Write Single Register or 16 (10h) Write Multiple Registers.

Protocol Address	Modicon Address	Data	Representation
02FEh	40767	Control word 1	See section 3.8 Control words
02FFh	40768	Control word 2	See section 3.8 Control words
0300h	40769	FBT Control Word	This register is used to read parameters (see fieldbus tasks).
0301h	40770	Fieldbus AO 1 (FBT Argument 2 or Internal analog output)	Parameter 12.37 Fieldbus AO1 decides the use of this register. If set as "FBT Argument 2", it is used to write parameters and set time (see fieldbus tasks). If set as "Internal analog output" this value of this register controls the internal analog output. Note that parameter 10.8 AO type needs to be set as "Fieldbus [%]".
0302h	40771	Fieldbus AO 2 (FBT Argument 3 or External analog output)	Parameter 12.38 Fieldbus AO2 decides the use of this register. If set as "FBT Argument 3", it is used to write parameters and set time (see fieldbus tasks). If set as "External analog output" this value of this register controls the external analog output. Note that parameter 11.14 1AOO type needs to be set as "Fieldbus [%]".

### 3.8. Control words

The control word registers are used to control the motor. These registers can be used as an alternative to using the digital output telegram (section 3.6).

Write control word using Modbus function code 6 Write Single Register or 16 (10h) Write Multiple Registers.

Protocol Address	Bit	Data	Description
02FEh	0	Start	Commence a start when signal is set.
	1	Stop	Commence a stop when signal is negated.
	2	Fault reset	Reset signal for possible events.
	3	Auto mode	This must be set for controlling the motor.
	4	Slow speed reverse	Perform slow speed reverse when signal is set.
	5	Slow speed forward	Perform slow speed when signal is set.
	6	Spare	
	7	Start1	Start1 if sequence start.
	8	Start2	Start2 if sequence start.
	9	Start3	Start3 if sequence start.
	10	Motor heating	Perform motor heating when signal is set.
	11	Stand still brake	Perform stand still brake when signal is set.
	12	Start reverse	Commence a reverse start when signal is set.
	13	Spare	
	14	Emergency mode	Set to "1" to enable emergency mode.
15	FBT Toggle Bit	See Fieldbus Tasks.	
02FFh	0	User defined trip	Set to "1" to trigger user defined protection.
	1	Switch to remote control	Switch to remote control when signal is set (rising edge triggered).
	2	Pump cleaning automatic	Perform automatic pump cleaning when signal is set.
	3	Pump cleaning forward	Perform forward pump cleaning when signal is set.
	4	Pump cleaning reverse	Perform reverse pump cleaning when signal is set.
	5	K4 relay command	Set "1" to activate the internal K4 output relay. Note that parameter 10.4 K4 function has to be set as "Fieldbus"
	6	K5 relay command	Set "1" to activate the internal K5 output relay. Note that parameter 10.5 K5 function has to be set as "Fieldbus"
7	K6 relay command	Set "1" to activate the internal K6 output relay. Note that parameter 10.6 K6 function has to be set as "Fieldbus"	

8	1DO0 relay command	Set "1" to activate the external 1DO0 output relay. Note that parameter 11.9 1DO0 function has to be set as "Fieldbus"
9	1DO1 relay command	Set "1" to activate the external 1DO1 output relay. Note that parameter 11.10 1DO1 function has to be set as "Fieldbus"
10	2DO2 relay command	Set "1" to activate the external 2DO2 output relay. Note that parameter 11.11 2DO2 function has to be set as "Fieldbus"
11	2DO3 relay command	Set "1" to activate the external 2DO3 output relay. Note that parameter 11.12 2DO3 function has to be set as "Fieldbus"
12	Refresh parameters	Automatic restart of fieldbus driver to refresh parameters
13	Spare	
14	Spare	
15	Spare	

It is recommended to give the start/stop commands to the Softstarter using bit 0, 1 in the control word 1 or protocol address 0100h, 0101h. Which of these registers that will be acknowledged by the device depends on the auto mode configuration.

If auto mode is set using protocol address 0103h, then the start/stop commands can be given using protocol address 0100h, 0101h. But if bit 3 in the control word 1 (protocol address 02FEh) is set, then the start/stop commands can be given using bit 0, 1 in the control word 1.

However, if auto mode is set in both protocol address 0103h and bit 3 in the control word 1, then start/stop commands will not be acknowledged by the device due to incorrect configuration.

Fault reset, FBT Toggle Bit, Switch to remote control, K4 relay command, K5 relay command, and K6 relay command can be done from both the digital output telegram and the control words even when auto mode is not enabled.

## 4. Modbus RTU - A set-up example

### 4.1. Softstarter PSTX Modbus RTU communication

This document describes an application example between a Modbus RTU master (PLC CPU, PC, etc.) and the ABB softstarter PSTX using the built-in Modbus RTU interface.

Please always use the actual softstarter manuals. In this particular example following documents has been used:

- Softstarter PSTX Installation and commissioning manual, document 1SFC132081M0201

### 4.2. Settings

#### 1. Set the softstarter address and field bus communication

Change the address of the softstarter to 47 (Fieldbus Address) and enable fieldbus control (Fieldbus control = On).

STATUS	SECURITY LEVEL	DOCUMENT ID.	REV.	LANG.	PAGE
Approved	Public	1SFC132089M0201	F	en	14/36

2. **Set the communication parameters**

Change the communication parameters baud rate, parity, stop bits to match the Modbus network settings.

3. **Select Com3 function**

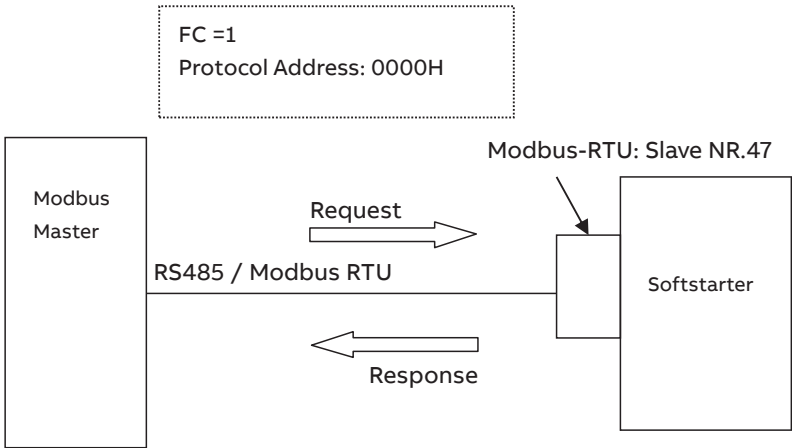
Change parameter Com3 function to Modbus RTU Slave to make the Modbus RTU interface available.

4. **Select the Modbus RTU interface**

The previous changes are taken in effect when the fieldbus interface is changed. Change parameter FB interface connector to Modbus RTU.

STATUS	SECURITY LEVEL	DOCUMENT ID.	REV.	LANG.	PAGE
Approved	Public	1SFC132089M0201	F	en	15/36

### 4.3. Read digital input telegram



E.g.: Read 16 bit starting at the address: 0000H

**Request:**  
 2F 01 00 00 00 10 3B 88

}    }    }

Slave 47	FC = 01	Address	16 bit	CRC
----------	---------	---------	--------	-----

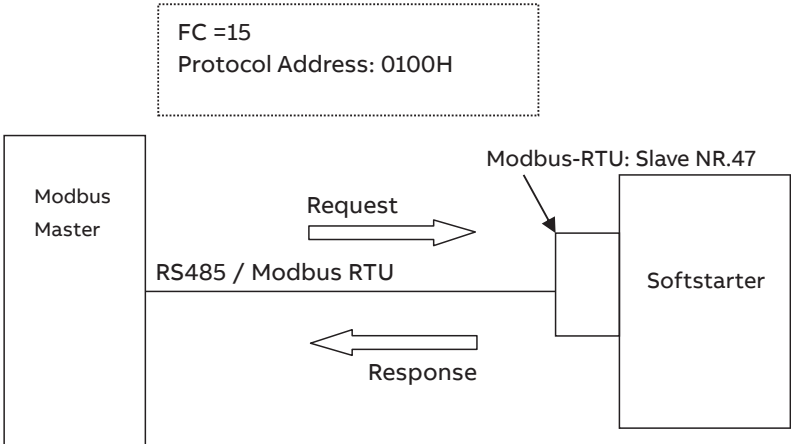
**Response:**  
 2F 01 02 00 00 51 FA

}

Slave 47	FC = 01	0 Byte	1 Byte	2 Byte	CRC
----------	---------	--------	--------	--------	-----



### 4.4. Write digital output telegram



E.g.: Write 16 bit starting at the address: 0100H

**Request:**

2F 0F 01 00 00 10 02 00 00 27 41



Slave 47	FC = 15	Address	16 bit	2 byte	Output	CRC
----------	---------	---------	--------	--------	--------	-----

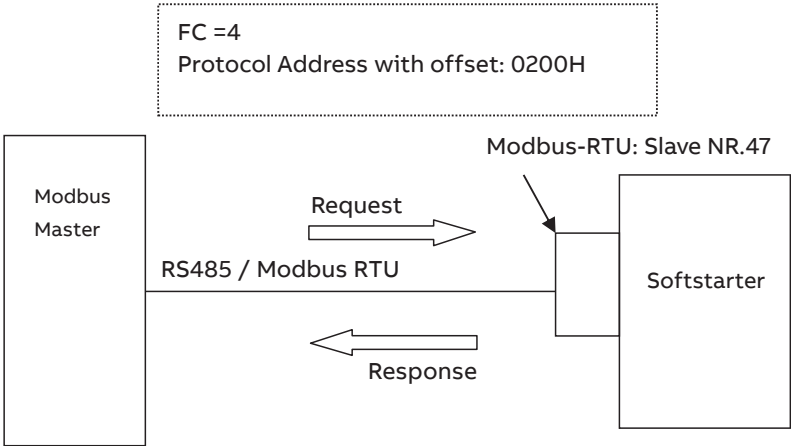
**Response:**

2F 0F 01 00 00 10 53 B5



Slave 47	FC = 15	Address	16 bit	CRC
----------	---------	---------	--------	-----

### 4.5. Read analog input telegram



E.g.: Read analog output words 2 & 3. Phase L1 current and Phase L2 current with default settings.

**Request:**

2F 04 02 01 00 02 27 FD



Slave 47  
 FC =4  
 Address  
 2 words  
 CRC

**Response:**

2F 04 04 00 00 00 00 35 86

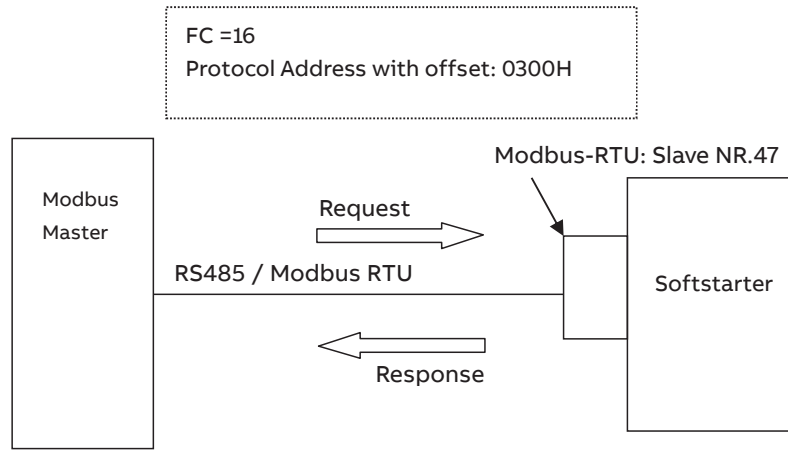


Slave 47  
 FC = 04  
 4 Byte  
 W0  
 W1  
 CRC

W0: Phase L1 current

W1: Phase L2 current

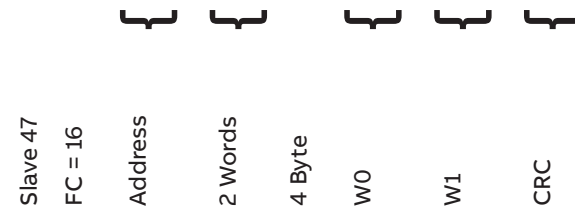
## 4.6. Write analog output telegram



E.g.: Write analog output words 1 & 2. FBT Control Word and FBT Argument 2.

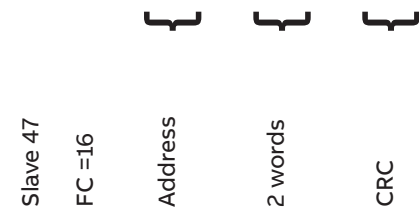
**Request:**

2F 10 03 00 00 02 04 00 00 00 00 78 77



**Response:**

2F 10 03 00 00 02 47 C2



W0: FBT Control Word

W1: FBT Argument 2

## 5. Fieldbus Tasks

By using Fieldbus Tasks it is possible to read/write parameters and set the real-time clock.

Which task to execute is selected by filling in the FBT Control Word. There are three signals for arguments to the task:

- FBT Argument 1 is packed together with the Task ID in the FBT Control Word.
- There are two additional 16-bit arguments in separate analog output signals, FBT Argument 2 and FBT Argument 3.

To control when the task is executed, the digital output signal FBT Toggle Bit shall be changed. The softstarter will detect the change, execute the task, fill in the return values, and toggle the digital input signal FBT Toggle Bit as acknowledgement. Thus, the return values must be disregarded if the two toggle bits have different value.

### 5.1. FBT Control Word

The control word is a 16-bit analog output value sent from the PLC to the softstarter. It consists of a Task ID and an 11-bit argument packed together.

<b>15</b>	<b>14, 13, 12,</b>	<b>11</b>	<b>10, 9, 8, 7, 6, 5, 4, 3, 2, 1, 0</b>
-	Task ID	-	Argument 1

### 5.2. Task ID

The task identifier controls which function should be performed.

Task ID	Task	Response ID	
		Positive	Negative
0	No task	0	-
1	Request parameter value, lower word	1	2
2	Change parameter value	1	2
3	Set date and time	1	2
4	Request parameter value, upper word	1	2

### 5.3. Response ID

The response ID is the softstarter response to a task. It tells whether a task was executed successfully. If there was an error, an additional error code is returned in the FBT Return Value analog input. The Response ID is transmitted as two digital input signals, FBT Response 0 and FBT Response 1.

Response ID	FBT Response 1	FBT Response 0	Explanation
0	0	0	No response
1	0	1	Task executed
2	1	0	Task cannot be executed (with error number)
3	1	1	Reserved.

## 5.4. Error codes

The following error codes are sent when a task cannot be executed.

Error code	Explanation
0	Illegal parameter number
1	Parameter value cannot be changed
3	Lower or upper limit violated
4	Invalid argument
5	No error
6	Invalid task number

## 5.5. Request parameter value, lower word

This task reads the lower 16 bits of the specified parameter. See chapter 5.9 for parameter number and value scaling information.

### 5.5.1. Arguments

- FBT Argument 1: parameter number.

### 5.5.2. Return Value

- Response ID 1 and parameter value in FBT Return Value on success.
- Response ID 2 and error number in FBT Return Value on failure.

## 5.6. Change parameter value

This task writes a specified value to a parameter. See chapter 5.9 for parameter number and value scaling information.

### 5.6.1. Arguments

- FBT Argument 1: parameter number.
- FBT Argument 2: parameter value (lower word)
- FBT Argument 3: parameter value (upper word)

### 5.6.2. Return Value

- Response ID 1 on success.
- Response ID 2 and error number in FBT Return Value on failure.

## 5.7. Set date and time

This task updates the real-time clock on the softstarter. The date and time fields have the following limits:

- Year: 0-63 (2000-2063)
- Month: 1-12
- Day: 1-31
- Hour:0-23
- Minute:0-59
- Second:0-59

### 5.7.1. Arguments

- FBT Argument 2: year, month, day and least significant bit of seconds

<b>15</b>	<b>14, 13, 12, 11, 10, 9</b>	<b>8, 7, 6, 5</b>	<b>4, 3, 2, 1, 0</b>
s0	year	month	day

- FBT Argument 3: hour, minute, seconds, bit 1-5

<b>15, 14, 13, 12, 11</b>	<b>10, 9, 8, 7, 6, 5</b>	<b>4, 3, 2, 1, 0</b>
Hour	minute	seconds, bit 1-5

### 5.7.2. Return Value

- Response ID 1 on success.
- Response ID 2 and error number in FBT Return Value on failure. In case the supplied time didn't differ from the set time, error code 5 (no error) is used.

## 5.8. Request parameter value, upper word

This task reads the upper 16 bits of the specified parameter. See chapter 5.9 for parameter number and value scaling information.

### 5.8.1. Arguments

- FBT Argument 1: parameter number.

### 5.8.2. Return Value

- Response ID 1 and parameter value in FBT Return Value on success.
- Response ID 2 and error number in FBT Return Value on failure.

STATUS	SECURITY LEVEL	DOCUMENT ID.	REV.	LANG.	PAGE
Approved	Public	1SFC132089M0201	F	en	22/36

## 5.9. Parameter numbers and values

To access parameters from the fieldbus a unique parameter number is needed, this can be found in document 1SFC132081M0201, Chapter 7.25 Complete parameter list.

Since the parameter values need to be represented as integers on the fieldbus while, the parameter values with greater precision need to be scaled. In document 1SFC132081M0201, Chapter 7.25 Complete parameter list, there is a column specifying the number of decimals for each parameter.

Parameter values that are read from the fieldbus needs to be divided by  $10^{\text{number of decimals}}$ .

Parameters values that are written from the fieldbus needs to be multiplied by  $10^{\text{number of decimals}}$ .

### For example:

The parameter Kick start time has parameter number 24 and 2 decimals. To read this parameter:

1. Set FBT Task ID to 1.
2. Set FBT Argument 1 to 24 to specify the parameter.
3. Toggle FBT Toggle Bit output and wait for the FBT Toggle Bit input to update.
4. Response ID 1 should now contain value 1, indicating success.
5. FBT Return Value contains the value 50 (this is an example and depends on the actual set value).
6. The return value should be interpreted as  $50/10^2 = 0.5s$ .

### To change the Kick start time parameter to 1s:

1. Set FBT Task ID to 2.
2. Set FBT Argument 1 to 24.
3. Set FBT Argument 2 to  $1 \cdot 10^2 = 100$ .
4. Set FBT Argument 3 to 0 as  $100 \leq 65535$  which means it doesn't require more than 16 bits.
5. Toggle FBT Toggle Bit output and wait for the FBT Toggle Bit input to update.
6. Response ID 1 should now contain value 1, indicating success.

### 5.9.1. Negative values

Negative values are represented internally using 32-bit two's complement numbers.

#### Example:

Setting parameter 17.5 PT100 reset temp (parameter number 249) to a value of -25°C: The two's complement of -25 is FFFFFFFE<sub>hex</sub>. The upper word is FFFF<sub>hex</sub> and the lower FFE7<sub>hex</sub>, in decimal notation 65535 and 65511.

1. Set FBT Task ID to 2 for Change parameter value.
2. Set FBT Argument 1 to 249 to specify the parameter.
3. Set FBT Argument 2 to 65511 to specify the lower word.
4. Set FBT Argument 3 to 65535 to specify the upper word.
5. Toggle FBT Toggle Bit output and wait for the FBT Toggle Bit input to update.
6. Response ID 1 should now contain value 1, indicating success.

STATUS	SECURITY LEVEL	DOCUMENT ID.	REV.	LANG.	PAGE
Approved	Public	1SFC132089M0201	F	en	23/36

## 6. Troubleshooting

### RS485

- Are the termination resistors placed at the end of the line?
- Only 2 termination resistors in one segment?
- Are 2 termination resistors placed at each bus segment?
- Are bias resistors connected in each bus segment?
- Is the line polarity correct? Are the lines by accident swapped?
- Never place any termination resistors on a drop cable.
- Is the maximum line length exceeded?

### Modbus slave

- Has the device a unique Modbus address?
- Is the function code supported by the device?
- Has the request a valid address?
- Has the request a valid quantity of coils, inputs, registers?
- Is the power supply turned on?

### Modbus master

- Is the Modbus master in RTU mode?
- Is the request to response timeout correct?
- Is the Modbus master silent interval between two telegrams > 3.5 character times?
- Notice that the slave device will not give any response when it is addressed with a broadcast (slave address = 0).
- Check if PLC is in run mode.

## 7. Example application with Automation Builder

This section shows a demo about how to start and stop motor by sending commands from fieldbus that is controlled by Programmable logic controller (PLC). We use Automation Builder as an example platform and show the demo about building such communication setting.

### 7.1. Create a new project in Automation Builder

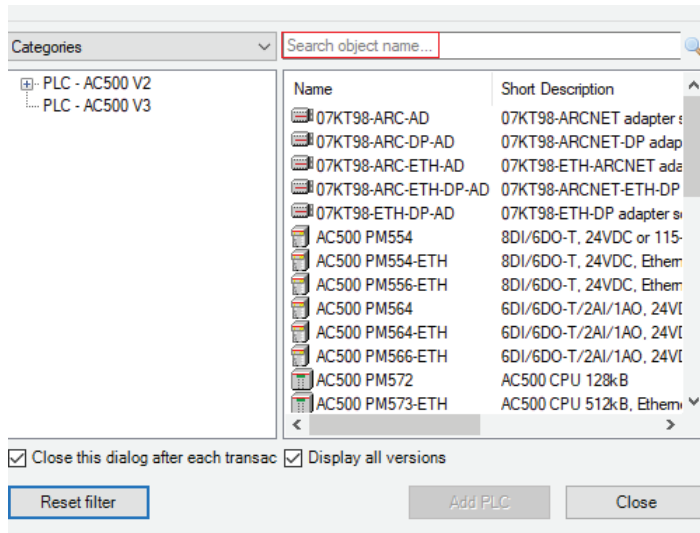
We perform the following steps in Automation Builder 2.1 for PLC AC500 PM573.

1. Open Automation Builder
2. Select File->New Project->AC500 project->OK

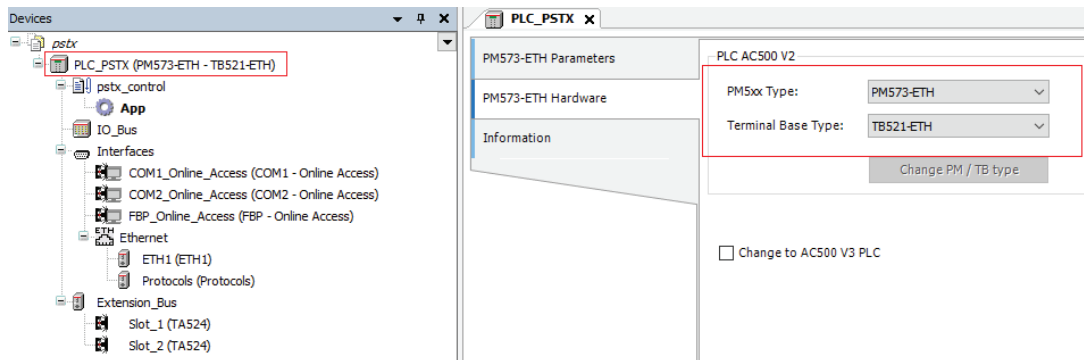
STATUS	SECURITY LEVEL	DOCUMENT ID.	REV.	LANG.	PAGE
Approved	Public	1SFC132089M0201	F	en	24/36



3. Select the correct PLC CPU in Search object name ...-> Add PLC.

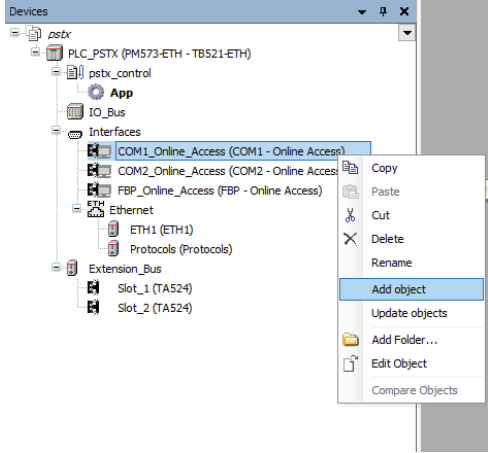


4. Check that the correct device type is selected by double clicking the device name in Devices field. Check that the correct Terminal Base Type is also selected for the tag for Hardware.

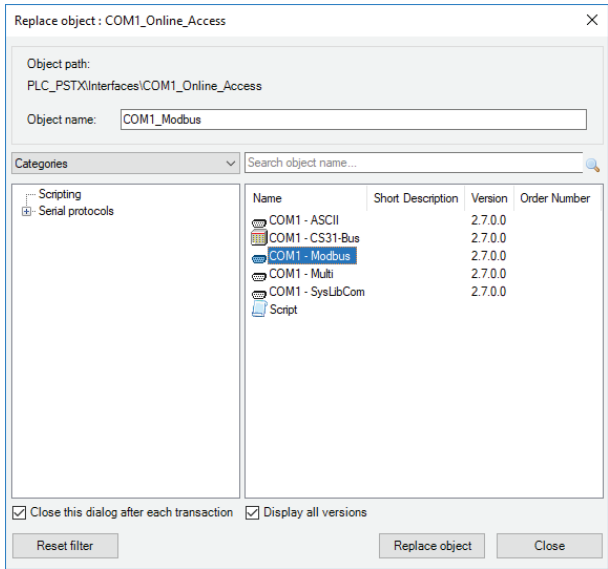


## 7.2. Add Modbus RTU master to project

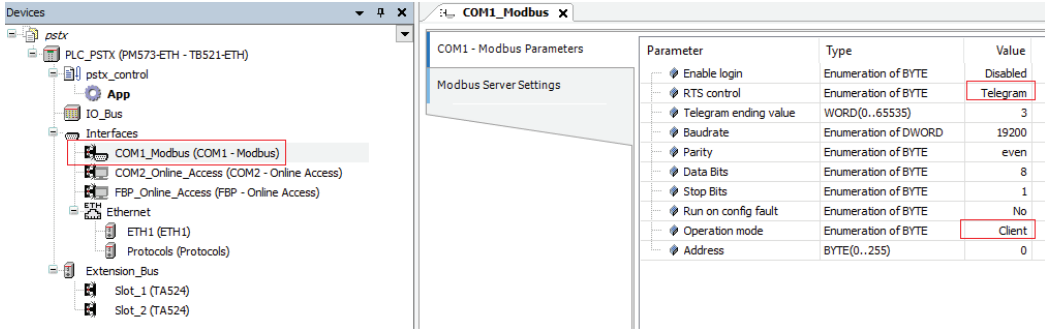
1. Right click on one of the COM ports and select Add object



2. Select COM1 - Modbus and click Replace object



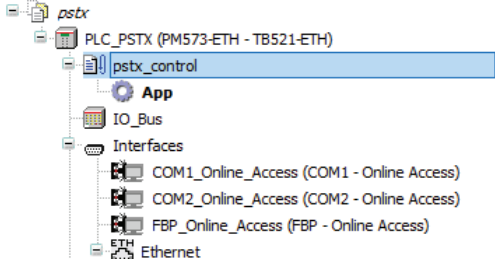
3. Double click interfaces, COM1\_Modbus, from the device tree. Set RTS control to Telegram and Operation mode to Client for COM1 – Modbus Parameters in COM1\_Modbus



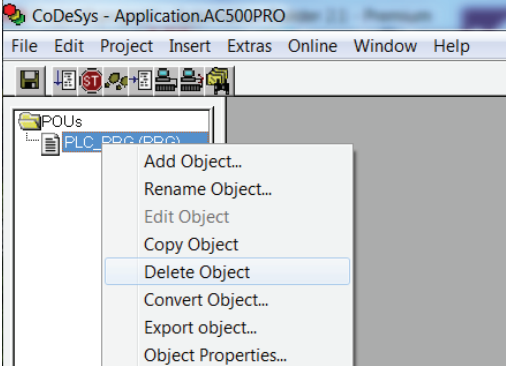
### 7.3. Build a START-STOP program

We perform the following steps for building our start-stop demo program in CoDeSys.

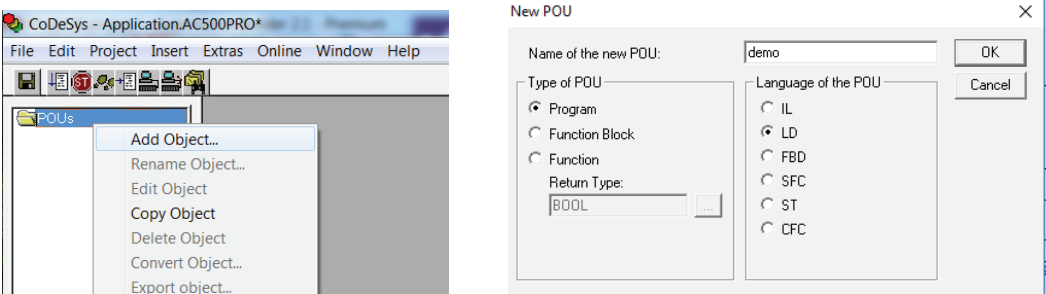
- 1. Open CoDeSys by double clicking your application in Devices file in Automation Builder, if it is not opened yet.



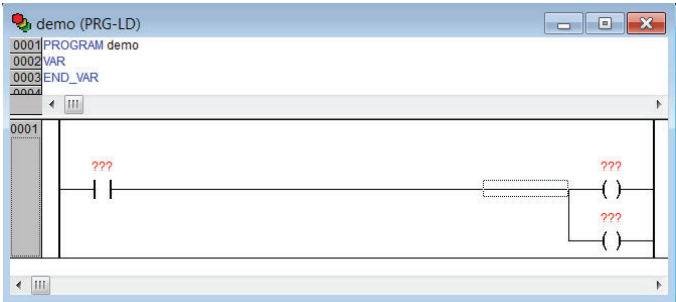
- 2. Delete the default POU by right click on it and select



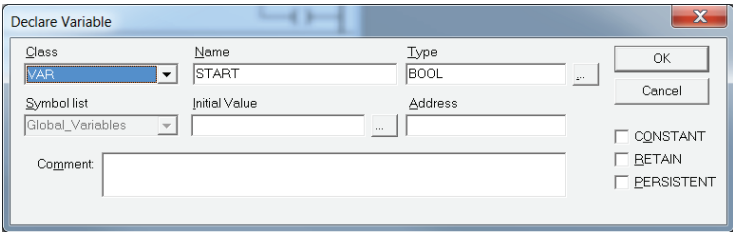
- 3. We choose to use LD as the language of the POU here by right click POU's -> Add Object... -> Insert Name of the new POU -> Choose "LD" for "Language of the POU" -> OK



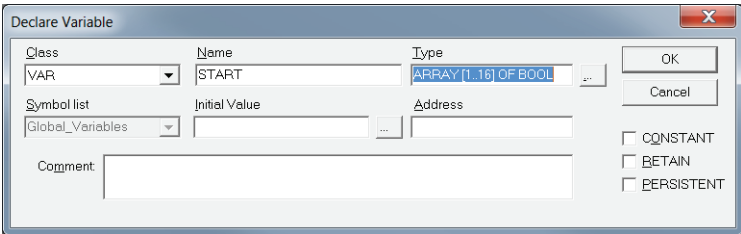
- 4. Open the newly created POU by double click it and select the first network, create a contact (by CTRL+K) and two coils (by CTRL+L)



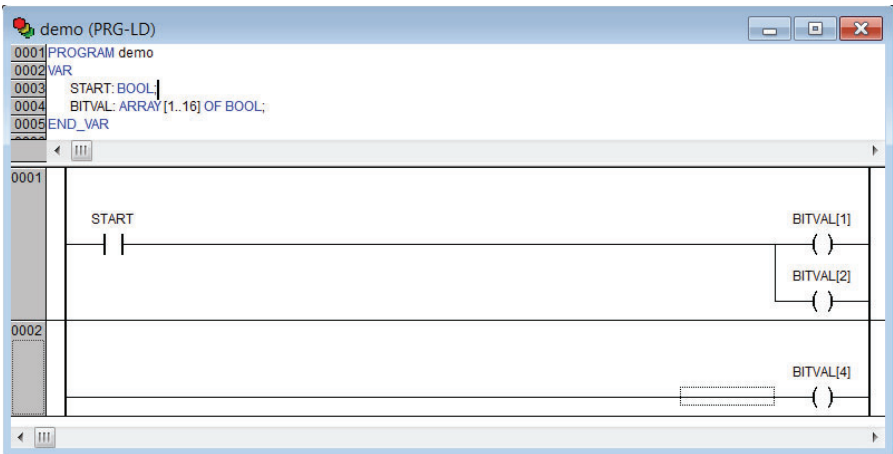
- 5. Name the contact START by changing the ??? to START, select type BOOL



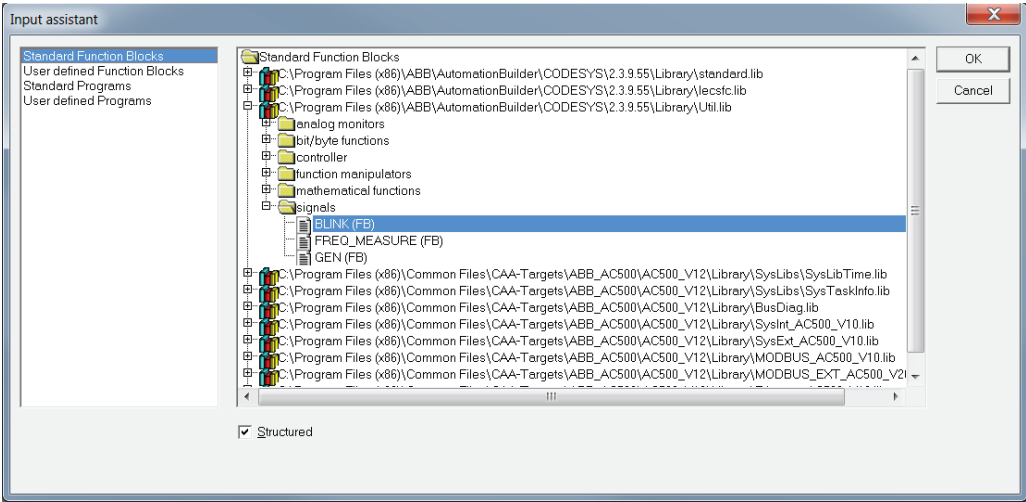
- 6. Name the coils "BITVAL[1]" and "BITVAL[2]", set the type to "ARRAY [1..16] OF BOOL"



- 7. Add a second network by CTRL+T and add a single coil (by CTRL+L) named "BITVAL[4]"

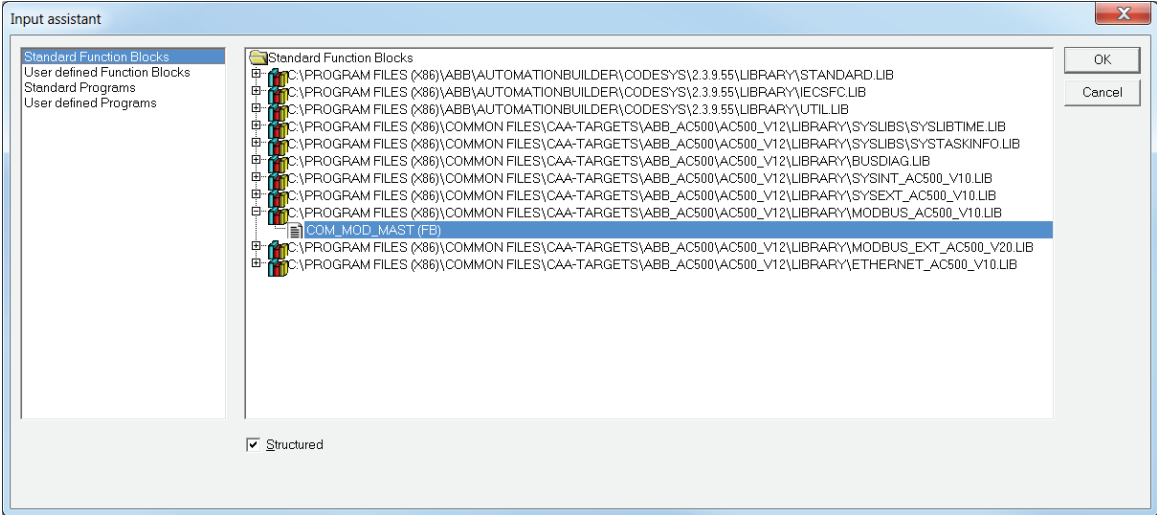


8. Add another network by CTRL+T. Create a function block “BLINK” by CTRL+B and select Standard Function Blocks -> Util.lib -> signals-> BLINK(FB)->Ok.

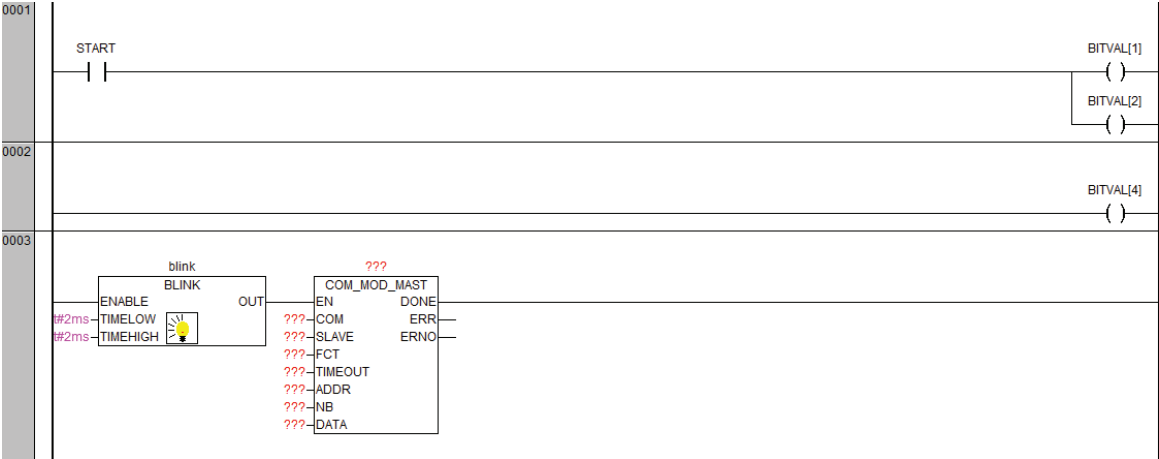


9. We name the BLINK function block as blink. We set t#2ms for TIMELOW and TIMEHIGH.

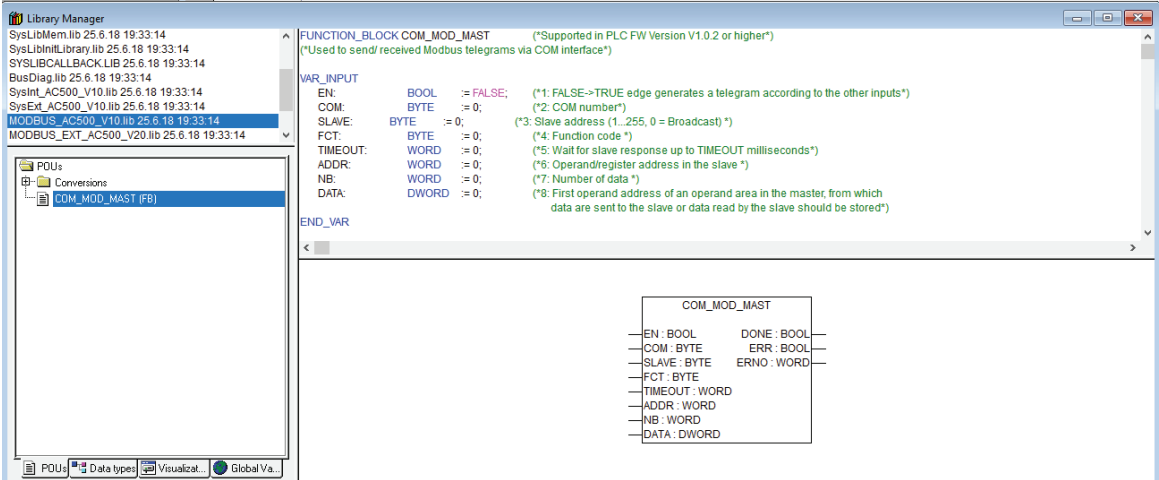
10. Continue to create a function block “COM\_MOD\_MAST” by CTRL+B and select Standard Function Blocks -> MODBUS\_AC500\_V10.LIB -> COM\_MOD\_MAST(FB) -> OK.



Now, we should have two function blocks in network 0003.



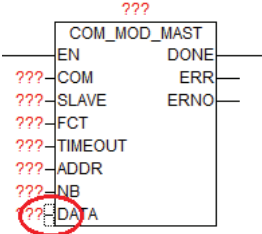
The COM\_MOD\_MAST is a function block for sending/receiving OpenModbus. Their definition is available from CoDeSys -> Resources -> Library Manager.



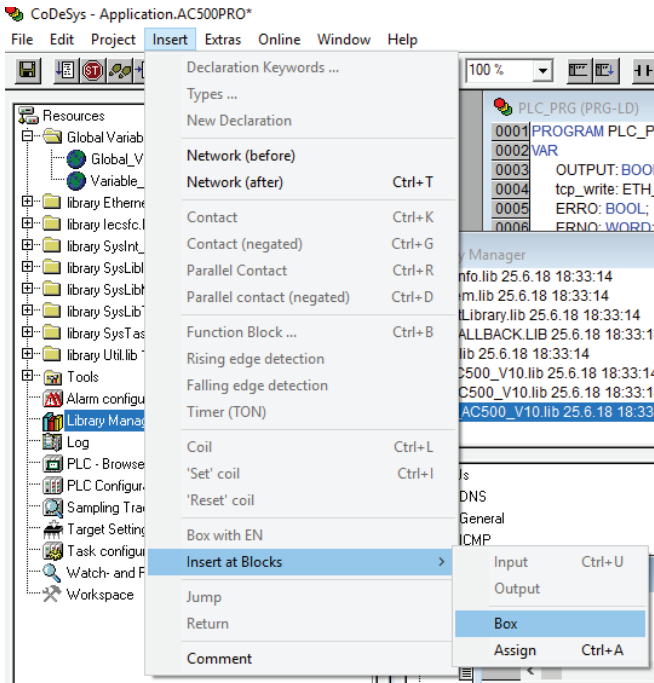
To enable this function block, it is required to send a FALSE->TRUE edge at input EN and therefore we introduce BLINK, which is for creating a flip-flop signal.

11. DATA (the data to send) require DWORD inputs. We can convert data with a box, "ADR".

a) Select the bar in front of DATA



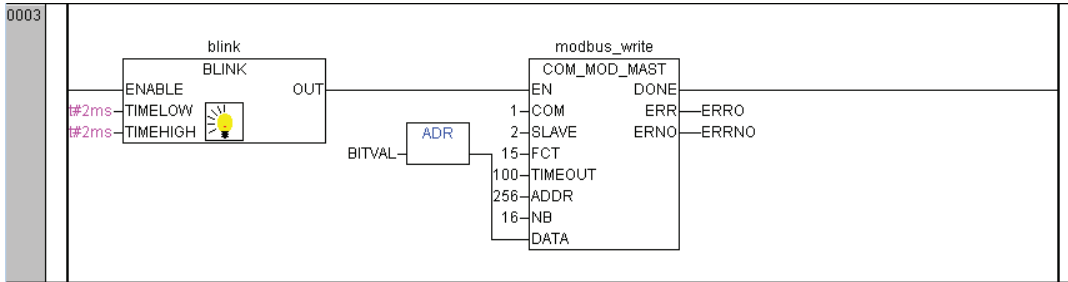
b) Choose Insert-> Insert at Blocks-> Box



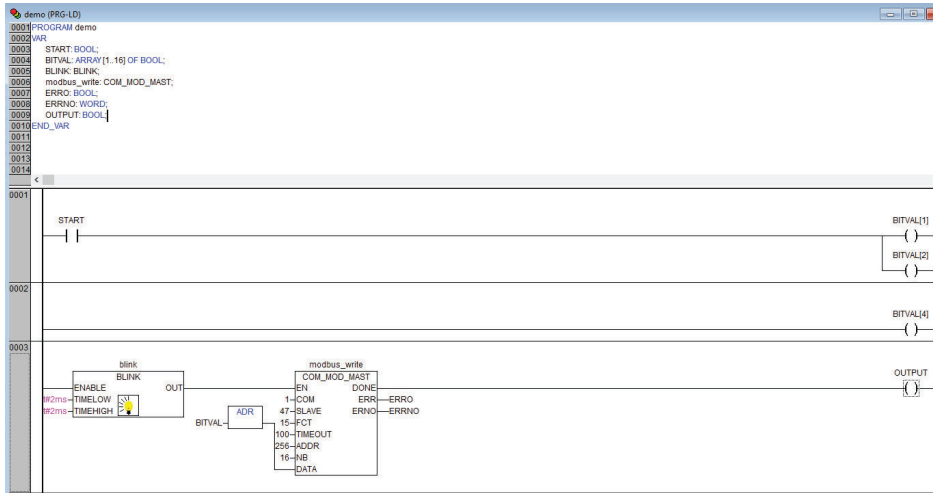
The default box is “AND”, change the name to ADR and it will be an ADR box.

12. Set:

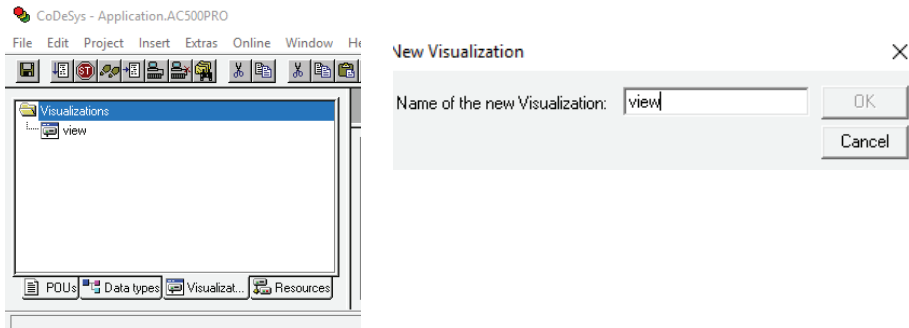
- The name of the block to modbus\_write
- COM to 1 or 2 depending on comport used
- Slave to the value of “Fieldbus address” (Parameter 12.4 in PSTX)
- FCT to 15
- TIMEOUT to 100
- ADDR to 256, according to Section 3.6, the first Protocol Address is 0100h.
- NB to 16
- ERR to ERRO (new BOOL variable)
- ERRNO (new WORD variable)




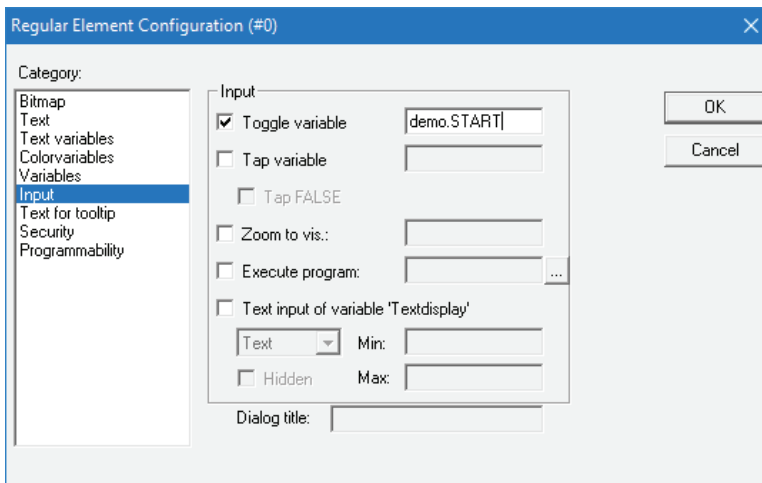
13. Insert a coil named "OUTPUT" in the last network and the LD-program is done.



14. Now we want to create one control button for signing the value of "START" from the first network into TRUE. We do this by Visualization -> right click -> Add object -> Write name of the new Visualization as "view" -> OK.

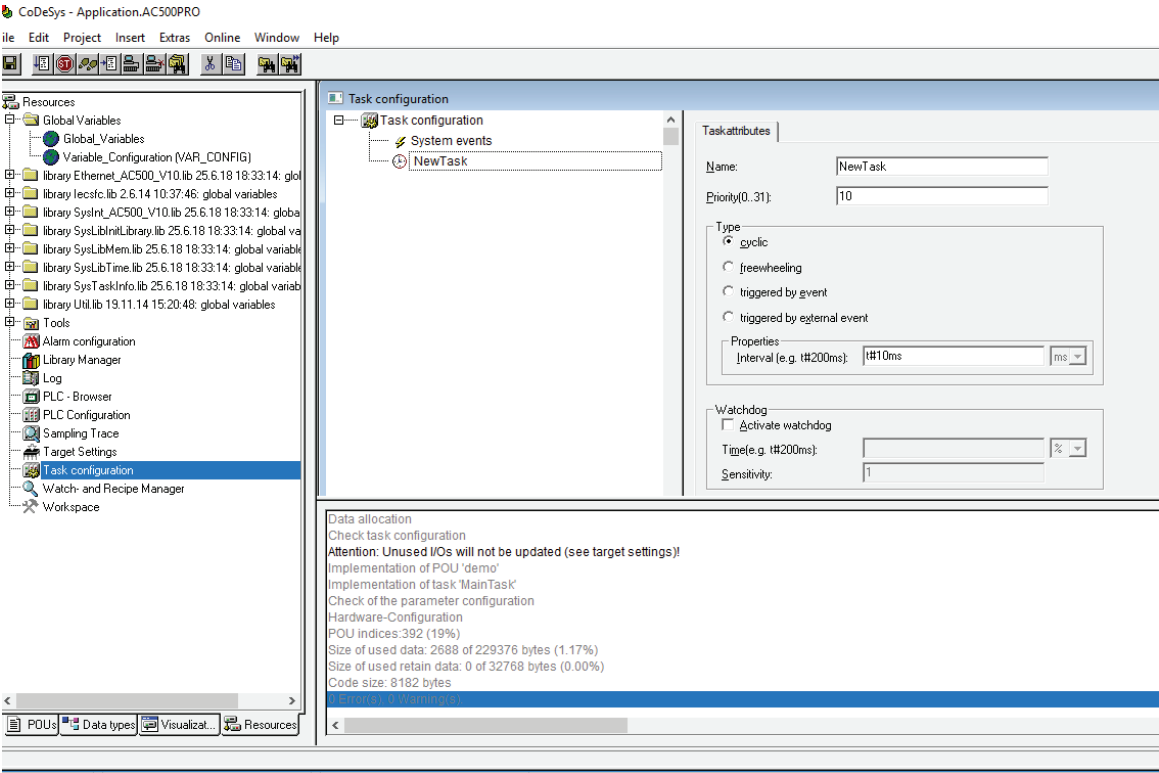


15. We draw a shape as the button  -> double click the shape -> Regular Element Configuration -> Input -> check Toggle variable -> insert "demo.START" ->OK.

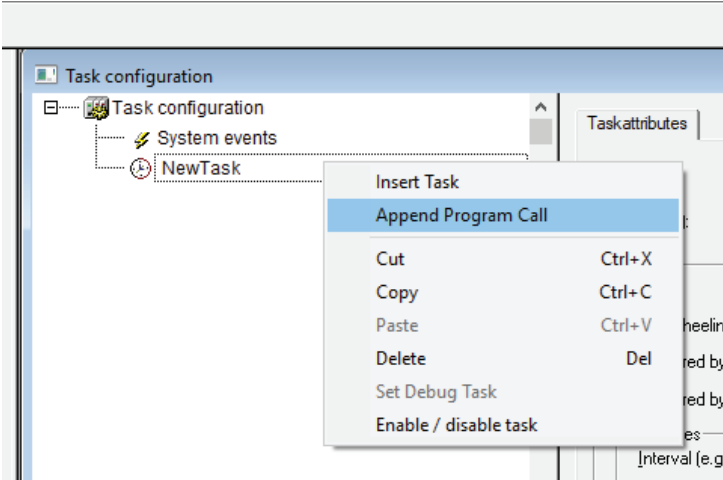




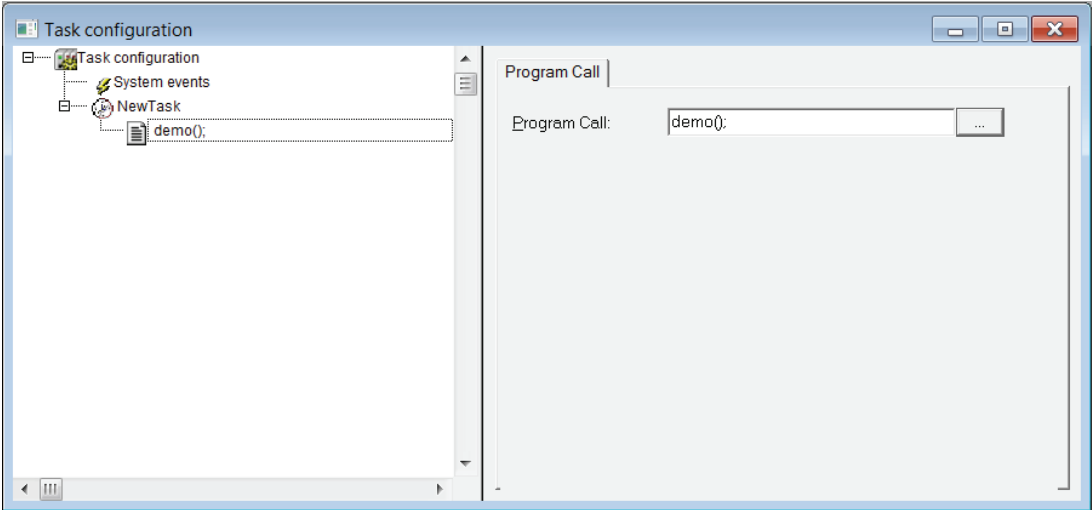
16. We configure this program into task configuration by Resource -> Task configuration -> Right click Task configuration -> Append Task -> Insert t#10ms in Properties in Taskattributes. Then we need to sign our program to this task by right click NewTask-> Append Program Call-> Choose demo(PRG) by clicking the select button in Program Call ->OK.



17. Right click on the NewTask and select Append Program Call.



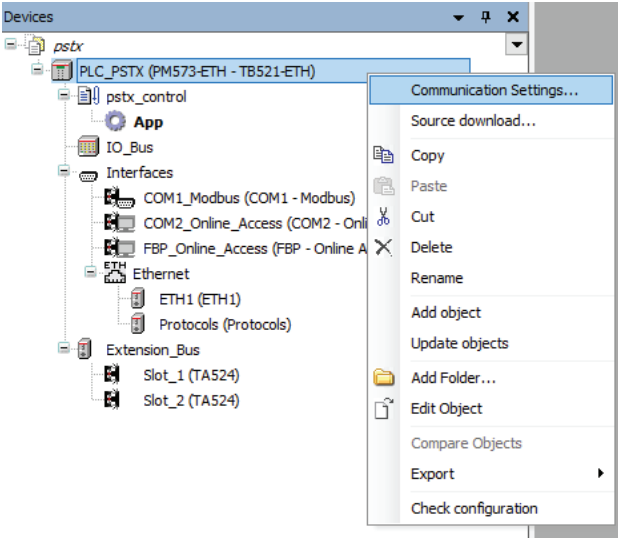
18. Select the demo program call.



19. Now we can build the project by Project -> Build. Check again if fieldbus is connected correctly. We can then run the program by pressing ALT+F8 and then F5.

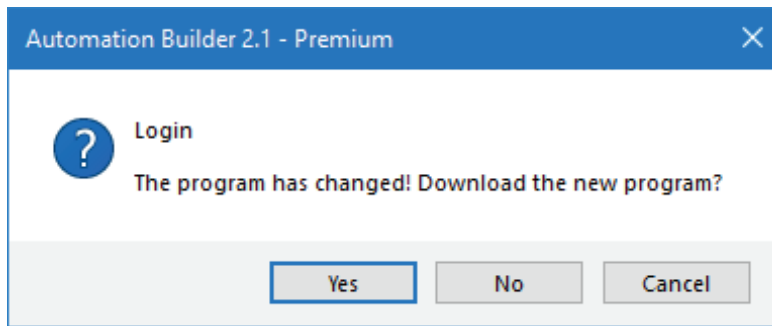
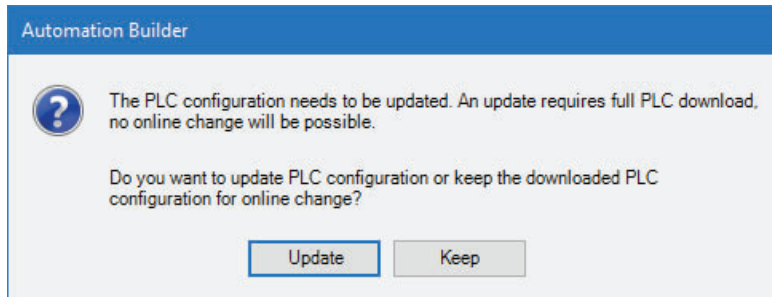
### 7.4. Connect to PLC using TCP/IP

1. Control the IP address for the device is also correct by right click the device name and then chose communication setting. The IP address should be the address of PLC CPU device.



2. Control that the IP address for PC and the PLC is in the same network but not the same IP address. This can be checked by using through Ethernet Properties.

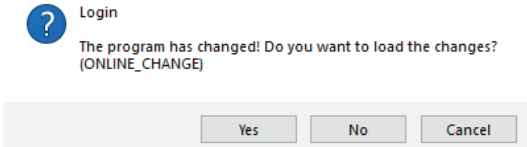
3. Click the icon “Login”, for building the configuration and checking if configuration is correct.
4. If the configuration is correct, a program for building PLC should be opened in the PLC environment, CoDeSys. Automation Builder will ask for downloading PLC configuration. Choose “Update”. Automation Builder will confirm that the program has changed.



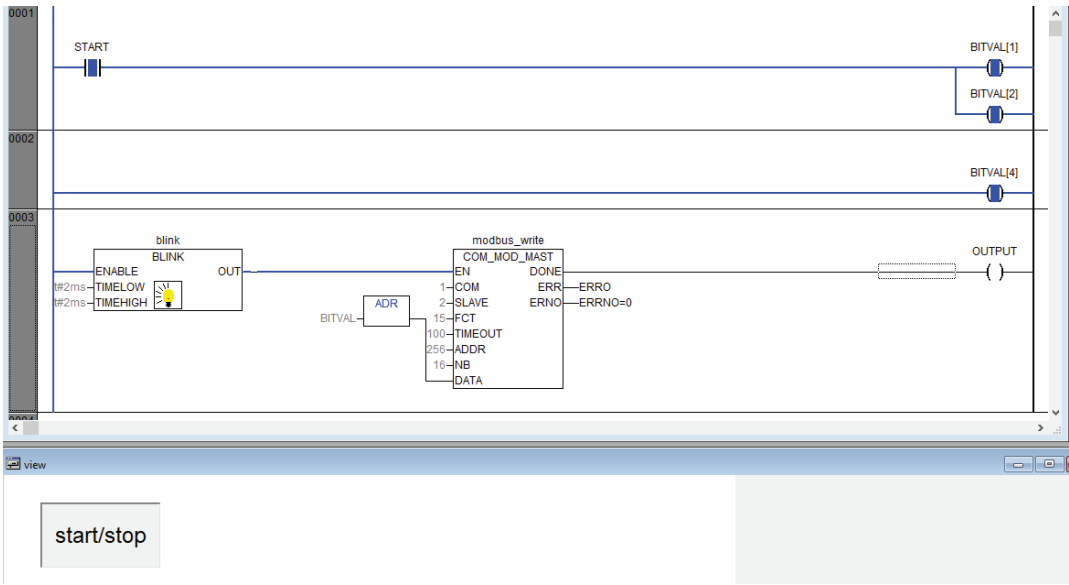
STATUS	SECURITY LEVEL	DOCUMENT ID.	REV.	LANG.	PAGE
Approved	Public	1SFC132089M0201	F	en	35/36

### 7.5. Build and run the PLC demo program

Use the key, F11, to build the program once. Login and start project from Automation Builder by clicking Alt+F8 to login the CodeSys. Click yes to login



Click F5 to start. Switch to CoDeSys and click Alt+F8 to login demo. The program can be controlled with the view from CodeSys



### 8. Contact us

For more information, please contact your local ABB representative or visit <https://solutions.abb/softstarters>

INSTRUCTION

# Softstarter Firmware Upgrade

## SoftstarterCare

### Contents

<b>1. Firmware upgrade</b> .....	<b>2</b>
1.1. How to upgrade PSTX firmware.....	2
1.2. How to upgrade PSE firmware.....	5
<b>2. Additional Information</b> .....	<b>10</b>
2.1. Listing of related documents.....	10
<b>3. Revisions</b> .....	<b>10</b>

PREPARED	STATUS	SECURITY LEVEL		
2022-02-10      Gustaf Soderlund	Approved	Public		
APPROVED	DOCUMENT KIND			
2022-02-21      Arshad Simitko	Technical Instruction			
OWNING ORGANIZATION	DOCUMENT ID.	REV.	LANG.	PAGE
Motor Starting & Safety	2CMT001197D0169	C	en	1/10

# 1. Firmware upgrade

Download and install the softstarter configuration tool SoftstarterCare from ABB Library. The latest softstarter firmware is also downloaded from ABB Library but requires ABB personnel privilege. Please click the following links to download the required firmware.

- SoftstarterCare™ – Service Engineer Tool
- ABB Softstarter firmware - PSTX
- ABB Softstarter firmware - PSE

## 1.1. How to upgrade PSTX firmware

The following sections explain how to perform a firmware upgrade on an ABB PSTX Softstarter.

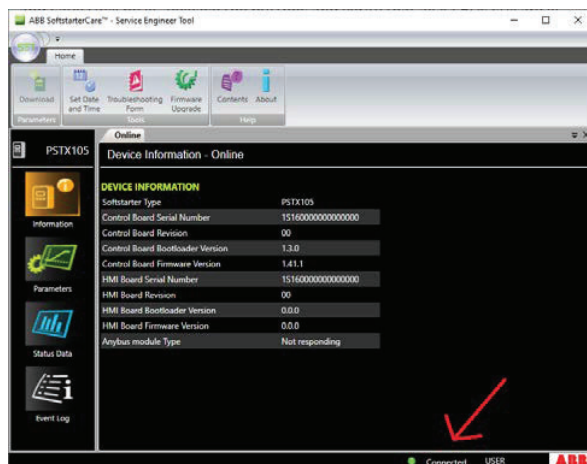
### 1.1.1. Control board firmware v1.22 and higher

1. Ensure that the PSTX softstarter is disconnected from operational voltage and control supply voltage (100-250V).
2. Set the PSTX HMI in boot mode.



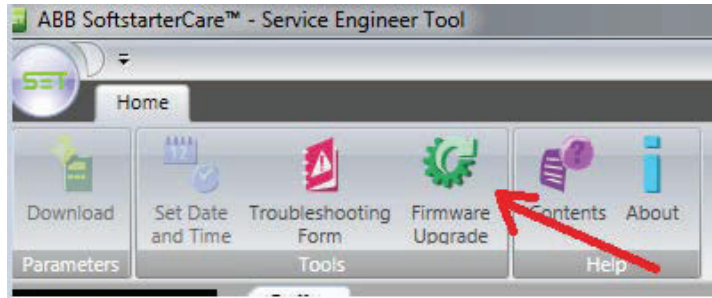
Hold both the stop and L/R button when connecting the USB cable between the PC and the PSTX HMI. This will set the HMI in boot mode and all four LEDs (Ready, Run, Protection and Fault) will be lit. Release the buttons and verify that all 4 LEDs still are lit.

3. Start SoftstarterCare and confirm that the softstarter is connected.

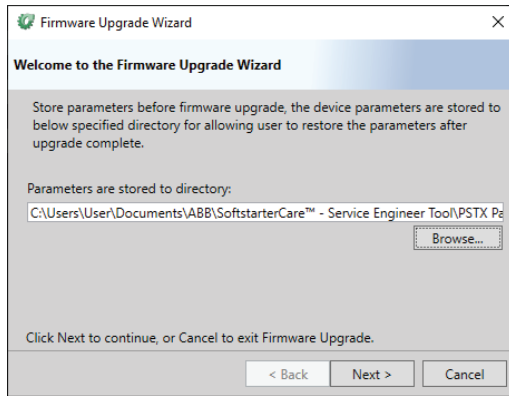


STATUS	SECURITY LEVEL	DOCUMENT ID.	REV.	LANG.	PAGE
Approved	Public	2CMT001197D0169	C	en	2/10

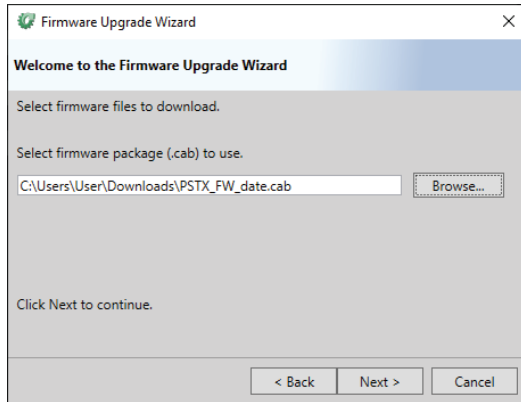
- Click on Firmware upgrade to start the firmware upgrade wizard.



- Select the directory SoftstarterCare will use to store the Softstarter parameter configuration and click Next.

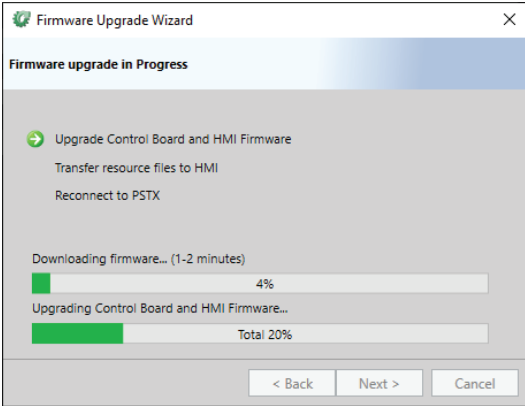


- Select the firmware (.cab) file downloaded from ABB Library and click Next.

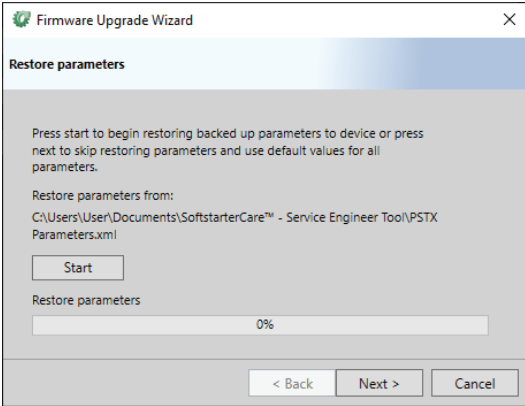


STATUS	SECURITY LEVEL	DOCUMENT ID.	REV.	LANG.	PAGE
Approved	Public	2CMT001197D0169	C	en	3/10

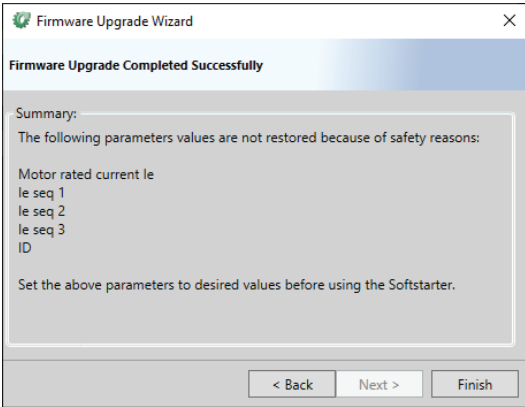
7. The firmware upgrade is now in progress and takes about 5 minutes to complete.



8. Click the Start button to restore the parameter configuration.



9. The upgrade is now completed. Click Finish to close the Firmware upgrade wizard.



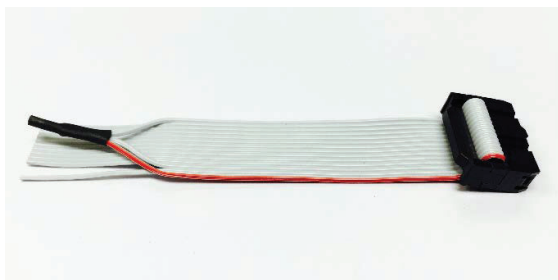


### 1.1.2. Control board firmware v1.22 and lower

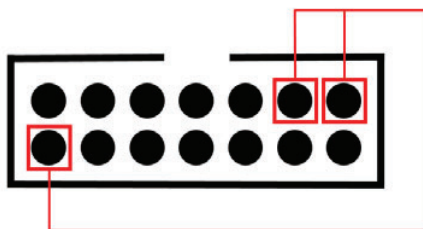
**IMPORTANT:** This instruction shall only be used for softstarters with control board firmware version lower than 1.22.0.

SoftstarterCare has very limited support for softstarters with old control board firmware, i.e., parameters backup/restore is not supported, only firmware upgrade is supported. In addition to the firmware upgrade instruction of softstarters with new control board firmware, two additional steps are needed for old control board firmware to not lose parameter configuration during firmware upgrade.

1. Write down all modified parameters. These parameters must be manually restored after firmware upgrade. To list the modified parameters, use the HMI and navigate to Menu->Parameters->Modified.
2. Ensure that the PSTX softstarter is disconnected from operational voltage and control supply voltage (100-250V).
3. Connect a jumper cable to the COM2 port to set the control board in boot mode. Contact softstarters support ([se-softstarters-support@abb.com](mailto:se-softstarters-support@abb.com)) to order one.



If you don't have the cable, it's still possible to get into boot mode by connecting the 3 pins shown in the picture below.



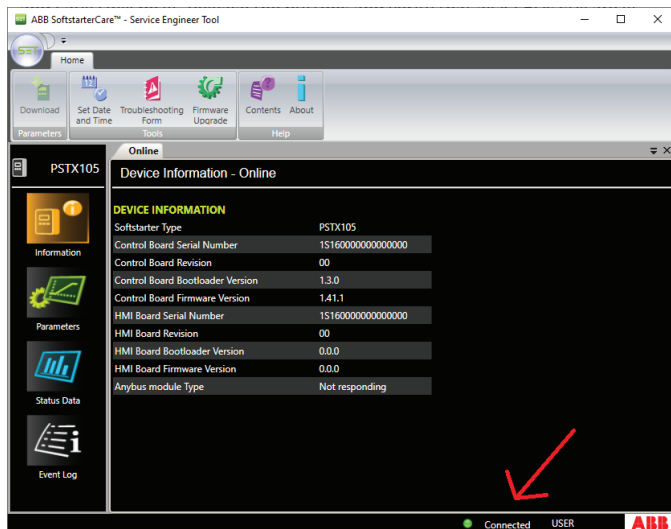
4. Set the PSTX HMI in boot mode.



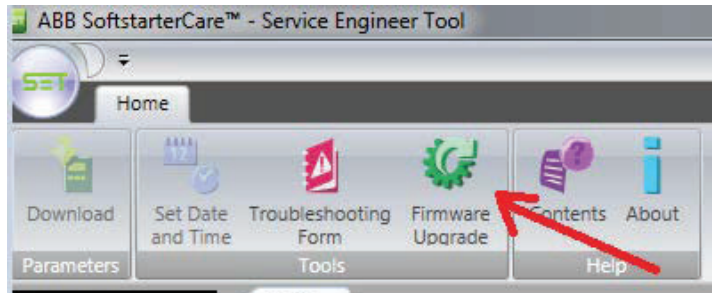
STATUS	SECURITY LEVEL	DOCUMENT ID.	REV.	LANG.	PAGE
Approved	Public	2CMT001197D0169	C	en	5/10

Hold both the stop and L/R button when connecting the USB cable between the PC and the PSTX HMI. This will set the HMI in boot mode and all four LEDs (Ready, Run, Protection and Fault) will be lit. Release the buttons and verify that all 4 LEDs still are lit.

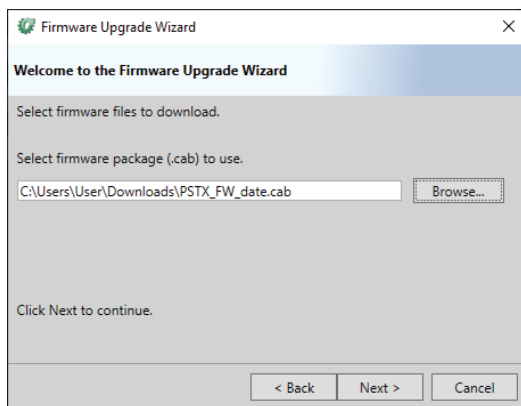
5. Disconnect the jumper cable from the COM2 port on the control board.
6. Start SoftstarterCare and confirm that the softstarter is connected.



7. Click on Firmware upgrade to start the firmware upgrade wizard.

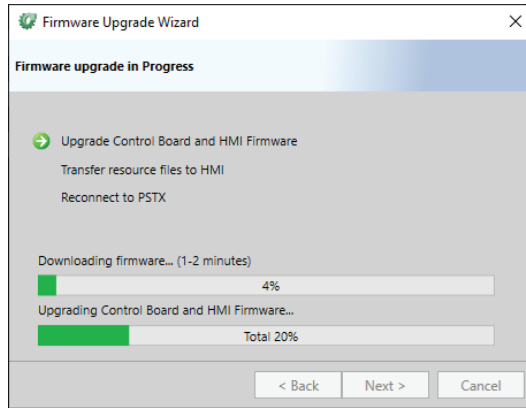


8. Select the firmware (.cab) file downloaded from ABB Library and click Next.

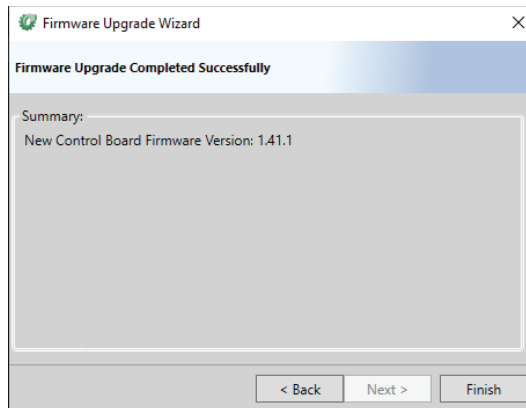


STATUS	SECURITY LEVEL	DOCUMENT ID.	REV.	LANG.	PAGE
Approved	Public	2CMT001197D0169	C	en	6/10

9. The firmware upgrade is now in progress and takes about 5 minutes to complete.



10. The upgrade is now completed. Click Finish to close the Firmware upgrade wizard.

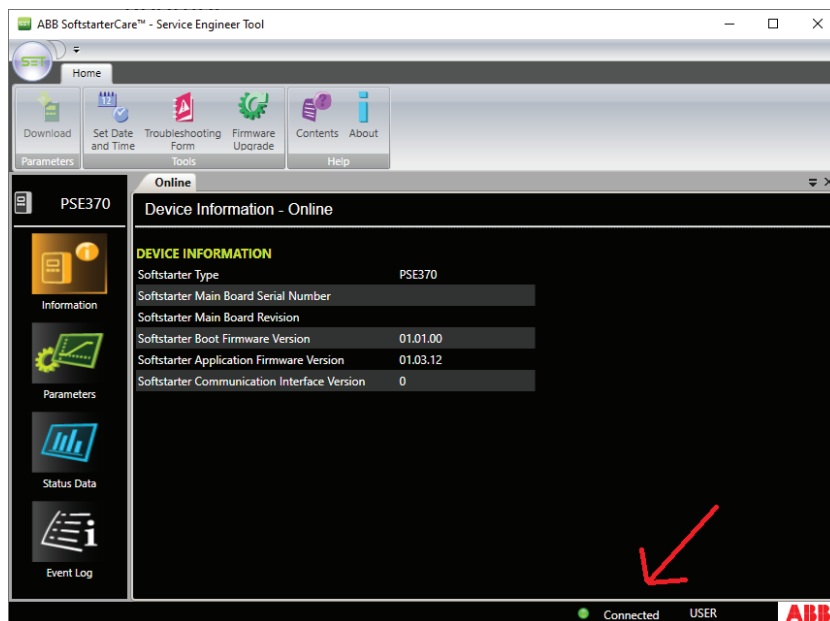


11. Restore the softstarter parameter configuration by setting each parameter according to the values saved in step 1.

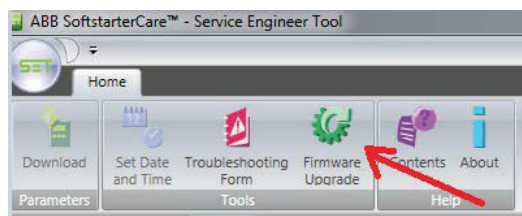
STATUS	SECURITY LEVEL	DOCUMENT ID.	REV.	LANG.	PAGE
Approved	Public	2CMT001197D0169	C	en	7/10

# How to upgrade PSE firmware

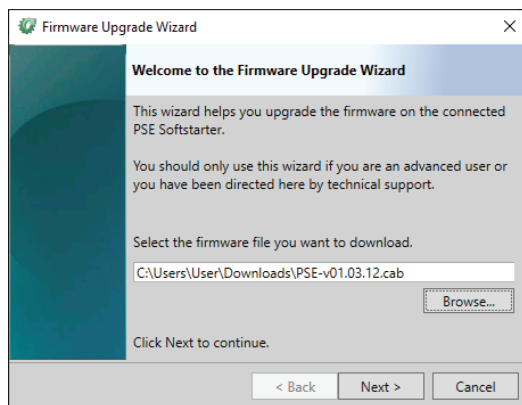
1. Ensure that the PSE softstarter is disconnected from operational voltage and control supply voltage (100-250V).
2. Use a PSECA USB cable to connect the PSE softstarter to your computer.
3. Start SoftstarterCare and confirm that the softstarter is connected.



4. Click on Firmware upgrade to start the firmware upgrade wizard.

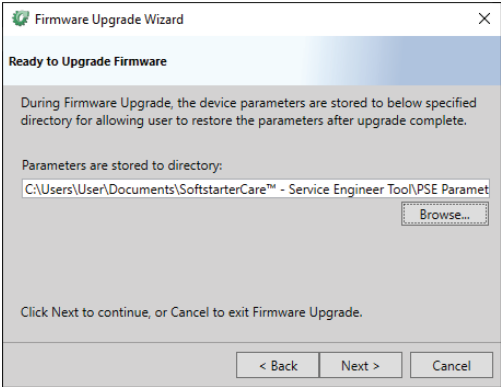


5. Select the firmware (.cab) file downloaded from ABB Library and click Next.

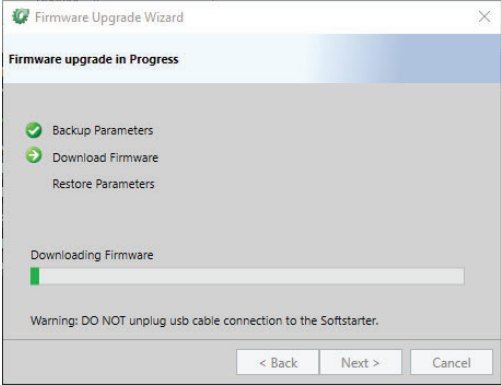


STATUS	SECURITY LEVEL	DOCUMENT ID.	REV.	LANG.	PAGE
Approved	Public	2CMT001197D0169	C	en	8/10

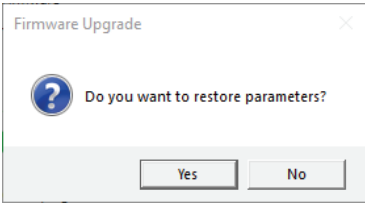
6. Select the directory SoftstarterCare will use to store the softstarter parameter configuration and click Next.



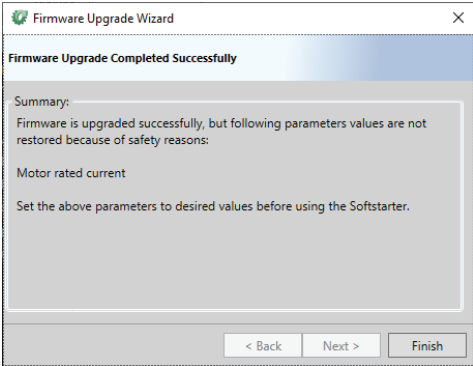
7. The firmware upgrade is now in progress. The upgrade takes about 1 minute to complete.



8. A message box asks whether you want to restore parameters or not. Click Yes to restore parameters.



9. The upgrade is now completed. Click Finish to close the Firmware upgrade wizard.



## 2. Additional Information

### 2.1. Listing of related documents

Ref #	Document Kind, Title	Document No.
1	PSTX - Installation and commissioning manual	1SFC132081M0201
2	PSE - Installation and commissioning manual	1SFC132057M0201

## 3. Revisions

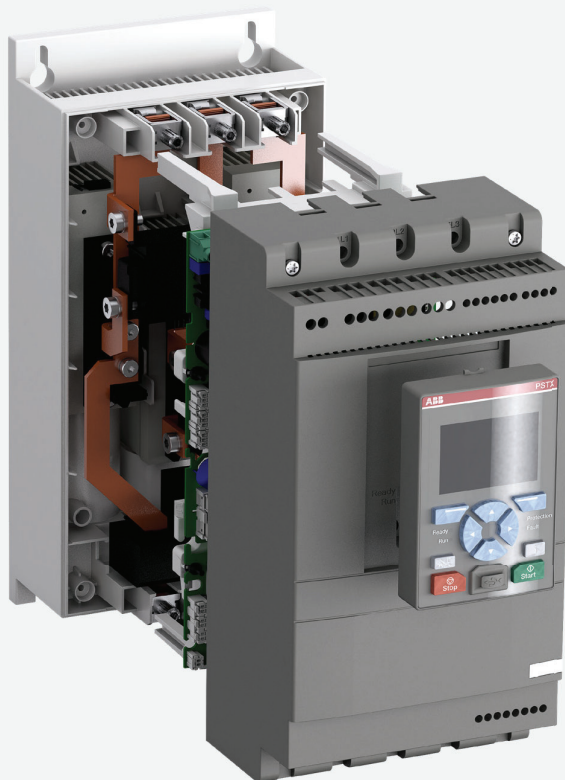
Rev.	Page (P) Chapt. (C)	Description	Date Dept./Init.
C		Added PSTX single CAB file instruction	2022-02-15

STATUS	SECURITY LEVEL	DOCUMENT ID.	REV.	LANG.	PAGE
Approved	Public	2CMT001197D0169	C	en	10/10

CATALOG

# Softstarter spare parts

## Type PSTX, PSE, PST(B), PSS



---

**The softstarters from ABB normally don't require any maintenance more than to brush off dust when needed.**

**It can of course happen that some component breaks down by external reason. In this catalogue you will find all the main parts available, also incl the HMI and plastic covers etc. We recommend using an ABB certified partner for the service.**



---

# Contents

**04**            **Service for softstarters**

**06**            **PSTX softstarter**

**26**            **Extended warranty**

---

# Service for softstarters

## Motor starting matters



ABB's softstarters increase a motor's lifetime by protecting it from electrical stresses. They do so by letting you optimize starting currents that with conventional starting methods put lots of stress on the motor. With many built-in motor protection features, your motor is safe in its hands. ABB's softstarters are also installation-friendly and can cut your assembly and startup time by being easy to use and easy to learn.

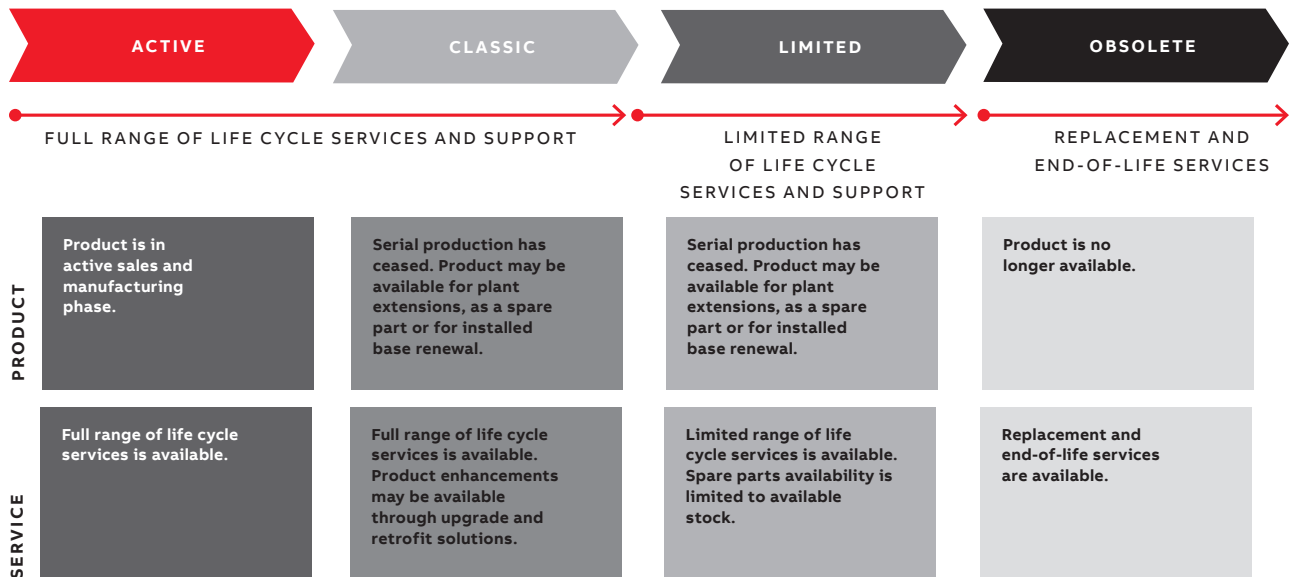
With everything that you need in one unit, from bypass contactor to overload protection, a single softstarter makes for a compact and complete starting solution. Furthermore, with many application specific features, ABB's softstarters can ultimately help you increase productivity. Torque control, pump cleaning and many more features let you do more than simply softstarting.



For more manuals and marketing materials scan the QR code or visit:  
[solutions.abb.com/softstarter-manuals](https://solutions.abb.com/softstarter-manuals)

You're in control of every life cycle phase of your softstarter. This table defines the services recommended and available throughout softstarter lifespan.

- Secure motor reliability
- Improve installation efficiency
- Increase application productivity

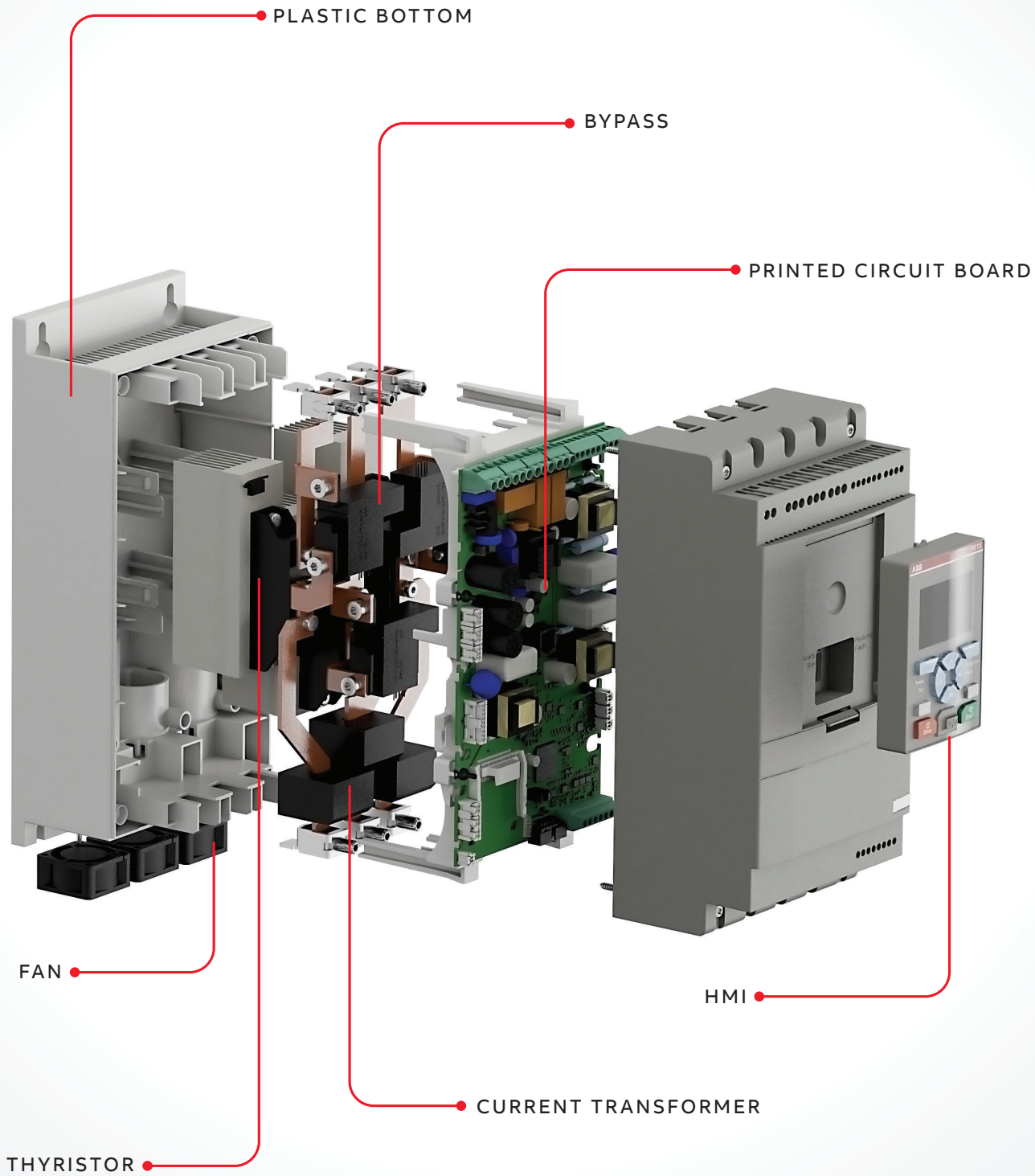


Legend of the column titles	
Description	A short description of the spare part
For softstarter type	The softstarter type the spare part is intended to
Type	The type code of the part
Order code	The global catalog number
Pcs/unit	The amount that is required for one softstarters
Pkg qty	The amount that is delivered per type code
Kg	The total weight of the package
Price	Enter your local price
Main voltage	If this is specified, it means that the part can handle the specified voltage. Otherwise, it will be applicable for all softstarters for this particular model and size.

**Example 2:** The cooling fan with ID 1SFA899215R1040 and type code PSFA-40 is delivered individual. If all three should be replaced, please order 3 x 1SFA899215R1040

**Example 3:** The thyristors in a PSTX470 for 600 V need to be replaced. The pkg quantity is 2, and the pcs per softstarter required is 6. If all thyristors should be replaced, 3 x 1SFA899211R2880 should be ordered.


# PSTX softstarter



## PSTX softstarter

### Spare parts

#### HMI

Description	For softstarter type	Type	Order code	Pcs/unit	Pkg qty	kg	Price
 HMI module <sup>1)</sup>	PSTX30... PSTX1250	PSDKP-1	1SFA899319R1001	1	1	0.33	
HMI spare part kit <sup>2)</sup>	PSTX30... PSTX1250	PSACC-1	1SFA899320R1001	1	1	0.14	

<sup>1)</sup>Including RJ45 connector, keypad unit and manual  
<sup>2)</sup>Including RJ45 connector, RJ45 cable, anybus connection cover, HMI gasket and nut, and rubber cover for HMI front.

Note: please read more in this document 1SFC132098M0201


PSDKP-1

#### USB cable for PSTX-PC connection

Description	For softstarter type	Type	Order code	Pcs/unit	Pkg qty	kg	Price
 Cable	PSTX30... PSTX1250	PSCA-1	1SFA899314R1001	1	1	0.05	


PSCA-1

#### Printed circuit board

Description	For softstarter type	Type	Order code	Pcs/unit	Pkg qty	kg	Price
 Control board 1	PSTX30...PSTX170	PSPCB-CB-1	1SFA899301R1007	1	1	0.65	
Control board 2	PSTX210...PSTX370	PSPCB-CB-2	1SFA899301R1008	1	1	0.66	
Control board 3	PSTX470...PSTX1250	PSPCB-CB-3	1SFA899301R1009	1	1	0.67	

PSPCB

#### Cooling fan

Description	For softstarter type	Type	Order code	Pcs/unit	Pkg qty	kg	Price
 Cooling fan	PSTX30...PSTX105	PSFA-40	1SFA899215R1040	3	1	0.03	
Cooling fan	PSTX142...PSTX170	PSFA-60	1SFA899215R1060	3	1	0.06	
Cooling fan	PSTX210...PSTX370	PSFA-80	1SFA899215R1080	3	1	0.07	
Cooling fan	PSTX470...PSTX1250	PSFA-80-1	1SFA899315R1080	4	1	0.09	

PSFA

Pcs/unit: The amount that is required for one softstarter  
 Pkg qty: The amount that is delivered per type code

## PSTX softstarter

### Spare parts

#### Side plate



PSSP-1

Description	For softstarter type	Type	Order code	Pcs/unit	Pkg qty	kg	Price
Side plate	PSTX470...PSTX570	PSSP-1	1SFA899304R1001	2	1	0.64	
Side plate	PSTX720...PSTX840	PSSP-2	1SFA899304R1002	2	1	1.17	
Side plate	PSTX1050...PSTX1250	PSSP-3	1SFA899304R1003	2	1	1.17	

#### End plate (Top plate)



PSEP-1

Description	For softstarter type	Type	Order code	Pcs/unit	Pkg qty	kg	Price
End plate	PSTX470...PSTX570	PSEP-1	1SFA899305R1001	1	1	0.17	
End plate	PSTX720...PSTX840	PSEP-2	1SFA899305R1002	1	1	0.32	
End plate	PSTX1050...PSTX1250	PSEP-3	1SFA899305R1003	1	1	0.36	

#### Fan plate



PSFP-1

Description	For softstarter type	Type	Order code	Pcs/unit	Pkg qty	kg	Price
Fan plate	PSTX470...PSTX570	PSFP-1	1SFA899306R1001	1	1	0.15	
Fan plate	PSTX720...PSTX840	PSFP-2	1SFA899306R1002	1	1	0.29	
Fan plate	PSTX1050...PSTX1250	PSFP-3	1SFA899306R1003	1	1	0.34	

#### Stays



PSSY-1

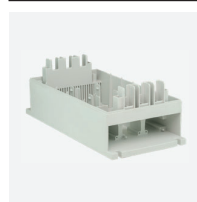
Description	For softstarter type	Type	Order code	Pcs/unit	Pkg qty	kg	Price
Stay	PSTX470...PSTX840	PSSY-1	1SFA899307R1840	2	1	0.13	
Stay	PSTX1050...PSTX1250	PSSY-2	1SFA899307R2250	2	1	0.15	

Pcs/unit: The amount that is required for one softstarter  
 Pkg qty: The amount that is delivered per type code

## PSTX softstarter

### Spare parts

#### Plastic bottom



PSEB-1

Description	For softstarter type	Type	Order code	Pcs/unit	Pkg qty	kg	Price
Plastic bottom	PSTX30...PSTX105	PSEB-1	1SFA899308R1001	1	1	1.27	
Plastic bottom	PSTX142...PSTX170	PSEB-2	1SFA899308R1002	1	1	1.90	
Plastic bottom	PSTX210...PSTX370	PSEB-3	1SFA899308R1003	1	1	3.67	

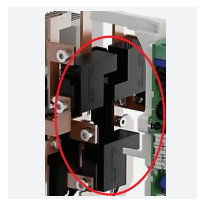
#### Bar holder



PSCBH-1

Description	For softstarter type	Type	Order code	Pcs/unit	Pkg qty	kg	Price
Circuit board bar holder	PSTX30...PSTX105	PSCBH-1	1SFA899312R1001	1	1	0.45	
Circuit board bar holder	PSTX142...PSTX170	PSCBH-2	1SFA899312R1002	1	1	0.62	
Circuit board bar holder	PSTX210...PSTX370	PSCBH-3	1SFA899312R1003	1	1	0.74	
Circuit board bar holder	PSTX470...PSTX1250	PSCBH-4	1SFA899312R1004	1	1	0.57	
Bar Holder	PSTX470...PSTX570	PSBH-5	1SFA899313R1005	2	1	0.84	
Bar holder	PSTX720...PSTX1250	PSBH-6	1SFA899313R1006	2	1	0.82	

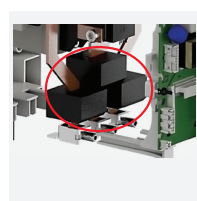
#### Bypass relay and contactor



PSBP-120

Description	For softstarter type	Type	Order code	Pcs/unit	Pkg qty	kg	Price
Bypass relay and contactor	PSTX30...PSTX105	PSBP-120	1SFA899201R1120	3	1	0.17	
Bypass relay and contactor	PSTX142...PSTX170	PSBP-200	1SFA899201R1200	2	1	0.33	
Bypass relay and contactor	PSTX210...PSTX370	PSBP-205	1SFA899301R1250	1	1	1.57	
Bypass relay and contactor	PSTX470...PSTX570	PSBP-370	1SFA899301R1570	1	1	4.61	
Bypass relay and contactor	PSTX720...PSTX1050	PSBP-750	1SFA899301R1750	1	1	15.0	
Bypass relay and contactor	PSTX1250	PSBP-1250	1SFA899301R2250	1	1	15.0	

#### Current transformers



PSCT-105

Description	Ratio	For softstarter type	Type	Order code	Pcs/unit	Pkg qty	kg	Price
Current transformer	105/0.025	PSTX30...PSTX105	PSCT-105	1SFA899302R1105	3	1	0.12	
Current transformer	175/0.025	PSTX142...PXTX170	PSCT-175	1SFA899302R1175	3	1	0.16	
Current transformer	370/0.200	PSTX210...PSTX370	PSCT-370	1SFA899302R1370	3	1	0.25	
Current transformer	570/0.200	PSTX470...PSTX570	PSCT-570	1SFA899302R1570	3	1	0.42	
Current transformer	840/0.200	PSTX720...PSTX840	PSCT-840	1SFA899302R1840	3	1	0.45	
Current transformer	1250/0.200	PSTX1050...PSTX1250	PSCT-1250	1SFA899302R2250	3	1	0.73	

Pcs/unit: The amount that is required for one softstarter  
 Pkg qty: The amount that is delivered per type code

## PSTX softstarter

### Spare parts

#### Terminal kit



Description	For softstarter type	Type	Order code	Pcs/unit	Pkg qty	kg	Price
Terminal kit	PSTX142...PSTX170	PSLE-185	1SFA899221R1002	2	2	0.20	
Terminal kit	PSTX210...PSTX370	PSLE-300	1SFA899221R1003	2	2	0.20	
Terminal kit	PSTX470...PSTX570	PSLE-460	1SFA899221R1004	6	6	0.56	
Terminal kit	PSTX720...PSTX1250	PSLE-750	1SFA899221R1005	6	6	0.68	

PSLE-185

#### Cleaning kit



Description	For softstarter type	Type	Order code	Pcs/unit	Pkg qty	kg	Price
Sufficient for replacing 10 thyristor blocks <sup>1)</sup>	PSTX30 ... PSTX370	PSPB-1	1SFA899012R1001	1	1	0.05	
Sufficient for replacing 20 thyristor disc <sup>2)</sup>	PSTX470 ... PSTX1250	PSPB-2	1SFA899012R1002	1	1	0.05	

<sup>1)</sup> The kit contains: Heat conducting paste tube ELFA NO 80-860-27 and instructions.

<sup>2)</sup> The kit contains: 25 ml Silicon oil, 1 pc Abrasive cloth, 2 pc Lint free paper, instructions.

PSPB-1



## PSTX softstarter

### Spare parts

#### Thyristor (SCR)



Thyristor

Description	Main voltage	For softstarter type	Type	Order code	Pcs/unit	Pkg qty	kg	Price
Thyristor (SCR)	<= 600 V	PSTX30	PSTHM-44/16	1SFA899210R1044	3	1	0.25	
Thyristor (SCR)	<= 600 V	PSTX37	PSTHM-56/16	1SFA899210R1056	3	1	0.25	
Thyristor (SCR)	<= 600 V	PSTX45	PSTHM-95/16	1SFA899210R1095	3	1	0.25	
Thyristor (SCR)	<= 600 V	PSTX60	PSTHM-95/16	1SFA899210R1095	3	1	0.25	
Thyristor (SCR)	<= 600 V	PSTX72	PSTHM-132/16	1SFA899210R1132	3	1	0.33	
Thyristor (SCR)	<= 600 V	PSTX85	PSTHM-132/16	1SFA899210R1132	3	1	0.33	
Thyristor (SCR)	<= 600 V	PSTX105	PSTHM-162/16	1SFA899210R1162	3	1	0.33	
Thyristor (SCR)	<= 600 V	PSTX142	PSTHM-200/16	1SFA899210R1200	3	1	0.33	
Thyristor (SCR)	<= 600 V	PSTX170	PSTHM-312/16	1SFA899210R1312	3	1	0.84	
Thyristor (SCR)	<= 600 V	PSTX210	PSTHM-312/16	1SFA899210R1312	3	1	0.84	
Thyristor (SCR)	<= 600 V	PSTX250	PSTHM-501/16	1SFA899210R1501	3	1	1.50	
Thyristor (SCR)	<= 600 V	PSTX300	PSTHM-501/16	1SFA899210R1501	3	1	1.50	
Thyristor (SCR)	<= 600 V	PSTX370	PSTHM-501/16	1SFA899210R1501	3	1	1.50	
Thyristor (SCR)	<= 600 V	PSTX470	PSTP-1880/16	1SFA899211R2880	6	2	0.51	
Thyristor (SCR)	<= 600 V	PSTX570	PSTP-2280/16	1SFA899211R3280	6	2	0.64	
Thyristor (SCR)	<= 600 V	PSTX720	PSTP-2880/16	1SFA899211R3880	6	2	0.65	
Thyristor (SCR)	<= 600 V	PSTX840	PSTP-3360/16	1SFA899211R4360	6	2	0.66	
Thyristor (SCR)	<= 600 V	PSTX1050	PSTP-4200/16	1SFA899211R5200	6	2	1.18	
Thyristor (SCR)	<= 600 V	PSTX1250	PSTP-5000/16	1SFA899211R6000	6	2	1.08	
Thyristor (SCR)	<= 690 V	PSTX30	PSTHM-44/18	1SFA899311R1044	3	1	0.25	
Thyristor (SCR)	<= 690 V	PSTX37	PSTHM-56/18	1SFA899311R1056	3	1	0.25	
Thyristor (SCR)	<= 690 V	PSTX45	PSTHM-95/18	1SFA899311R1095	3	1	0.25	
Thyristor (SCR)	<= 690 V	PSTX60	PSTHM-95/18	1SFA899311R1095	3	1	0.25	
Thyristor (SCR)	<= 690 V	PSTX72	PSTHM-132/18	1SFA899311R1132	3	1	0.33	
Thyristor (SCR)	<= 690 V	PSTX85	PSTHM-132/18	1SFA899311R1132	3	1	0.33	
Thyristor (SCR)	<= 690 V	PSTX105	PSTHM-162/18	1SFA899311R1162	3	1	0.33	
Thyristor (SCR)	<= 690 V	PSTX142	PSTHM-200/18	1SFA899311R1200	3	1	0.33	
Thyristor (SCR)	<= 690 V	PSTX170	PSTHM-312/18	1SFA899311R1312	3	1	0.84	
Thyristor (SCR)	<= 690 V	PSTX210	PSTHM-312/18	1SFA899311R1312	3	1	0.84	
Thyristor (SCR)	<= 690 V	PSTX250	PSTHM-501/18	1SFA899311R1501	3	1	1.50	
Thyristor (SCR)	<= 690 V	PSTX300	PSTHM-501/18	1SFA899311R1501	3	1	1.50	
Thyristor (SCR)	<= 690 V	PSTX370	PSTHM-501/18	1SFA899311R1501	3	1	1.50	
Thyristor (SCR)	<= 690 V	PSTX470	PSTP-1880/18	1SFA899311R2880	6	2	0.46	
Thyristor (SCR)	<= 690 V	PSTX570	PSTP-2280/18	1SFA899311R3280	6	2	0.64	
Thyristor (SCR)	<= 690 V	PSTX720	PSTP-2880/18	1SFA899311R3880	6	2	0.65	
Thyristor (SCR)	<= 690 V	PSTX840	PSTP-3360/18	1SFA899311R4360	6	2	0.66	
Thyristor (SCR)	<= 690 V	PSTX1050	PSTP-4200/18	1SFA899311R5200	6	2	1.18	
Thyristor (SCR)	<= 690 V	PSTX1250	PSTP-5000/18	1SFA899311R6000	6	2	1.08	

# Extended warranty

## For ABB Low Voltage products



—  
Scan the QR code for more information or visit: <https://to.abb/HT70ludG>

### Extended warranty

Warranty for ABB Low Voltage control products, extending the standard factory warranty up to 3 years has never been this simple.

Request extended warranty activation after the online registration in the "Extended warranty tool."

This web tool verifies that the device's application is within the recommended guidelines and grants the product registration.

The customer can request the extended warranty during the standard warranty period of already purchased products.

—  
The warranty covers any possible issues related to the product quality.

The extended warranty can be ordered by the following steps:

- 1 | Go to the Extended warranty tool
- 2 | Enter the product serial number in the "extended warranty tool" within the standard warranty period

—  
01 AF Contactors > 100 A



—  
02 UMC 100.3



—  
03 Softstarters



—  
04 CP-C.1 Power supplies



## Extended warranty timeline





—  
For more information, please contact  
your local ABB representative or visit:  
**[solutions.abb/softstarters](https://solutions.abb.com/softstarters)**

For more information about service visit:  
**<https://new.abb.com/low-voltage/service/service-for-low-voltage-products>**



To get more information,  
install QR code reader on  
your mobile device, scan the  
code and see more.

# Softstarter type PSTX30...370

## Spare part instruction - Replace the HMI and accessories

1SFC132098M0201 June 2015

Rev B

EN | Spare part instruction

| Softstarter type PSTX30...370

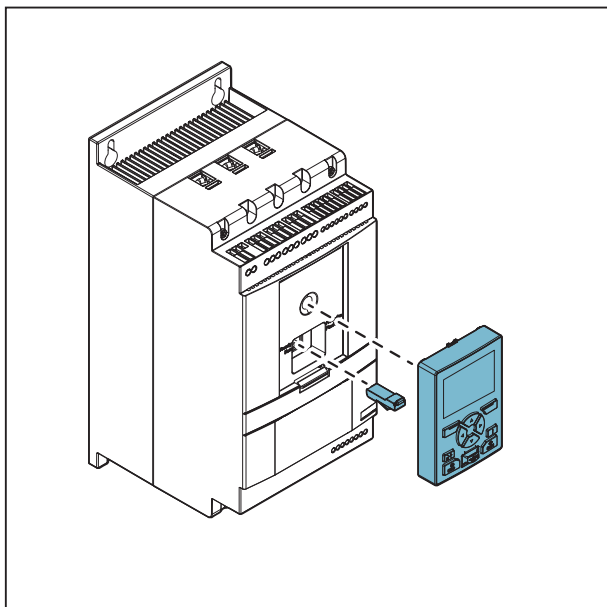
| Replace the HMI and accessories

### General

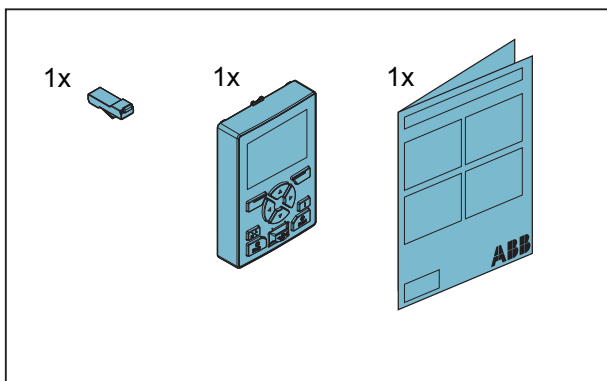
For complete information, see 1SFC132081M0201 - Softstarters Type PSTX30...PSTX370, Installation and Commissioning Manual available on: <http://www.abb.com/lowvoltage>

**i** Service and repair should be performed by authorized personnel only. Note that unauthorized repair affects safety and warranty.

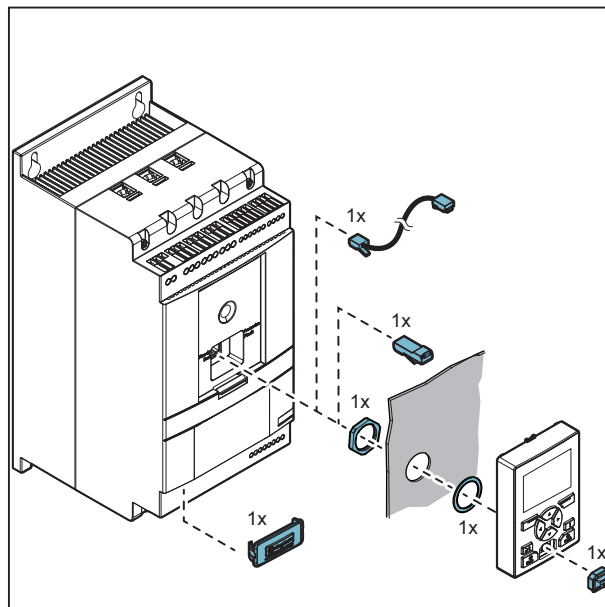
### 1. Replace the HMI



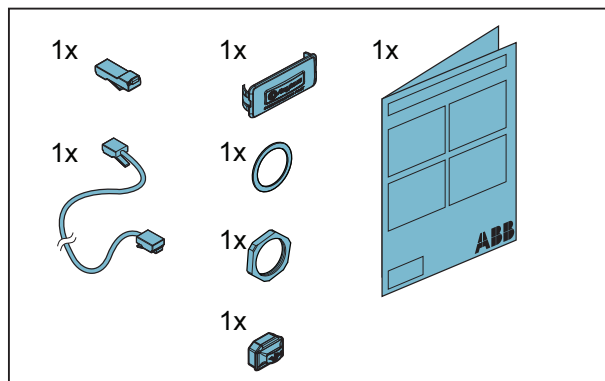
1SFA899319R1001 - PSDKP-1



### 2. Replace the accessories



1SFA899320R1001 - PSACC-1



## Safety information



**Important information:** A qualified electrician must carry out installation, commissioning and service on the product by following installation standards and regulations. The product user hazardous voltage that can cause death or serious injury. Always disconnect power before working on equipment. Do not touch terminals when voltage is applied, output terminals can have live voltage even when the device is in off position. The product should only be used within the specified ratings. Check that you have the correct product in regards to mains voltage, supply voltage and rated product data.



**Viktig information:** Installation, idrifttagning och service av denna produkt skall endast utföras av behörig el-personal. Säkerhets- och installationsnormer skall följas. Produkten använder livsfarlig spänning, innan arbete utförs ska alltid spänningen frånskiljas. Rör inga anslutningar när produkten är spänningssatt, anslutningarna är spänningssatta även när produkten är i frånläge. Produkten skall endast användas inom dess specificerade data, kontrollera den gentemot huvudspänning, kontrollspänning och övriga märkdata.



**Wichtige Information:** Installation, Inbetriebnahme und Service dieses Produktes darf nur durch qualifiziertes Fachpersonal unter Beachtung der nachfolgenden Hinweise und Erklärungen erfolgen. Die in dem Gerät vorhandenen Spannungen können bei Berührung zu tödlichen oder ernsthaften Verletzungen führen. Vor Arbeiten an dem Gerät ist grundsätzlich die Versorgung abzuschalten. Bei Anliegen der Versorgungsspannung dürfen keine Klemmen berührt werden, an den Ausgangsklemmen kann auch bei ausgeschaltetem Gerät eine gefährliche Spannung anliegen. Der Einsatz des Gerätes darf nur innerhalb der spezifizierten Bedingungen erfolgen. Überprüfen Sie vor Einsatz, dass die Geräetype bezüglich Versorgungsspannung, Schaltspannung und sonstiger Daten den Anforderungen entspricht.



**Informazioni importanti:** L'installazione, la messa in servizio e la manutenzione di questo prodotto devono essere effettuate solo da un elettricista qualificato, seguendo fedelmente le disposizioni in materia di installazione e sicurezza. Il prodotto utilizza tensioni pericolose che possono causare gravi danni o morte. Scollegare sempre l'alimentazione prima di accedere all'apparecchio. Non toccare mai i terminali quando l'apparecchio è sotto tensione: i terminali di uscita sono in tensione anche quando l'apparecchio è SPENTO. Prima dell'istallazione; verificare di aver scelto il prodotto corretto specialmente in termini di tensione di alimentazione, principale ed ausiliaria, ma più in generale per tutte le caratteristiche tecniche. Il prodotto va utilizzato solo nelle condizioni specificate.



**重要信息:** 产品的安装、调试及运行必须由具备资质的专业电工遵照相关标准及安全规范完成。产品使用能致命或引起严重伤害的危险电压。在产品上进行操作时务必断开电源。通电时不可接触接线端子，产品关断后输出端子仍有电压。产品仅能按照规定额定值使用。检查主回路电压，控制回路电压及其它产品参数符合产品规定。



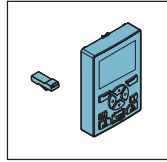
**Informations importantes:** Un électricien qualifié doit exécuter l'installation, la mise en service et l'entretien de ce produit en suivant les normes d'installation et les règles de sécurité. Le produit utilise une tension dangereuse qui peut causer la mort ou des blessures graves. Toujours débrancher l'alimentation avant de travailler sur l'équipement. Ne touchez pas les prises de raccordements lorsqu'une tension est appliquée, les prises de raccordements de sortie auront toujours une tension résiduelle, même si l'appareil est sur OFF. Le produit doit être seulement utilisé dans les calibres spécifiées. Vérifiez que vous avez le bon produit en ce qui concerne la tension du secteur, la tension d'alimentation nominale et les données produits.



**Важная информация:** Установка, ввод в эксплуатацию и обслуживание данного оборудования должны производиться квалифицированным персоналом, специально допущенным к таким работам, в соответствии с действующим законодательством и требованиями предъявляемыми к обслуживанию электроустановок и обеспечению безопасности. В изделии используется опасное для человека напряжение, которое может привести к смерти или серьезным травмам. Всегда отключайте напряжение перед началом любых работ на оборудовании. Не дотрагивайтесь до клемм и токоведущих частей когда приложено напряжение. На выходных клеммах может быть напряжение даже если прибор выключен. Прибор должен использоваться строго в соответствии с заявленными параметрами. Проверьте, что прибор подобран правильно и номинальные параметры находятся в соответствии с силовым напряжением и напряжением управления.

**تحذير:** يسمح فقط للفني أو المهندس الكهربائي المختص للقيام بأعمال التثبيت و التجهيز و الصيانة لهذا النوع من الاجهزة وذلك من خلال اتباع انظمة التوصيل والتثبيت الكهربائية العلامية وشروط السلامة المعتمدة. هذا النوع من الاجهزة يستخدم جهد خطر قد يؤدي لحدوث الاصابة أو الوفاة . دائما افصل مصدر التيار قبل بدء العمل على الجهاز . لاتلمس أطراف التوصيل عندما يكون هنالك جهد مطبق لأن مخارج أطراف التوصيل تحتفظ بلاجهد حتى بعد فصل مصدر الجهد. هذا الجهاز يجب استخدامه مع ما يناسبه من قيم محددة . تأد دائما من حصولك على الجهاز المناسب لمصدر الفولتية والتردد والقيم المحددة للتيار .

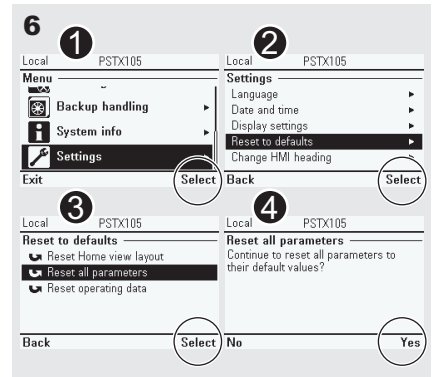
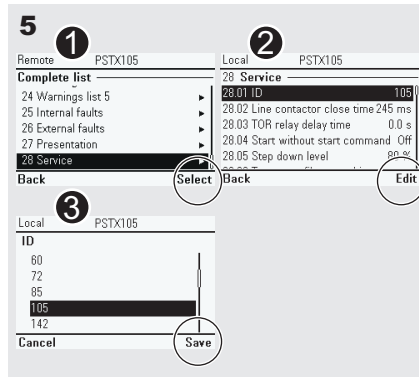
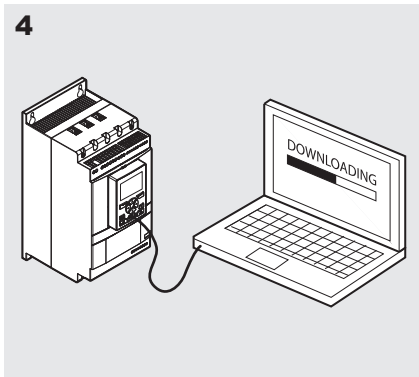
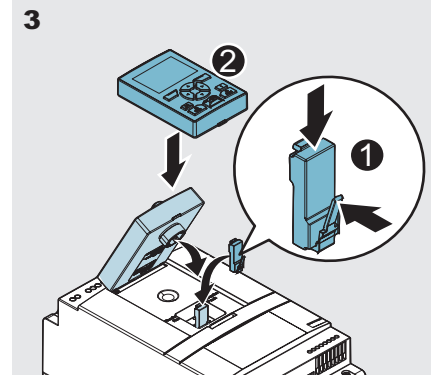
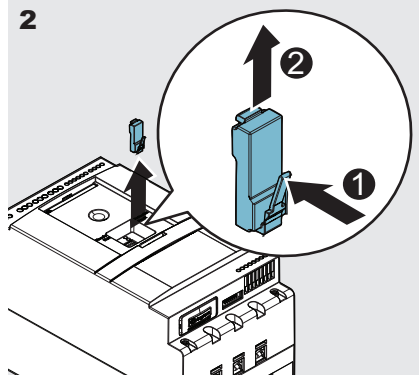
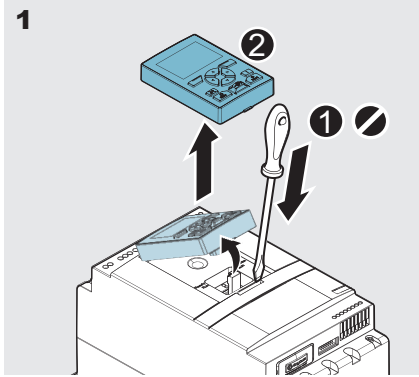
# 1. Instruction - Replace the HMI



## CAUTION

Always make sure that the power supply is switched off before doing maintenance on the Softstarter.

## PSTX30...370



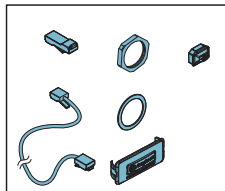
Firmware needs to be updated when changing the HMI. Please contact your ABB sales office for information. **See Figure 4**

## 2. Instruction - Replace the accessories

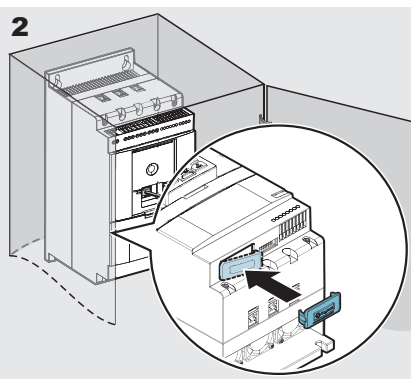
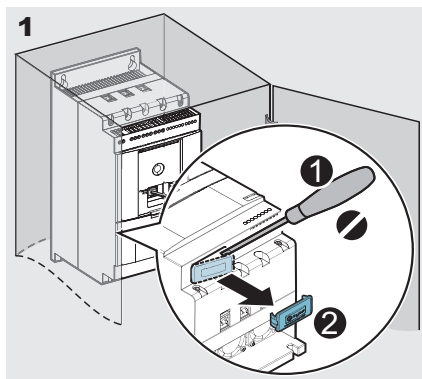
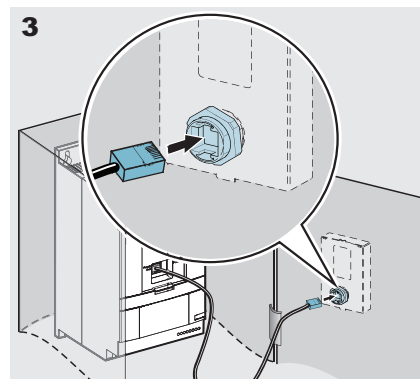
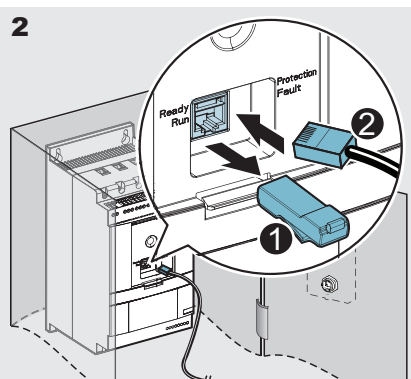
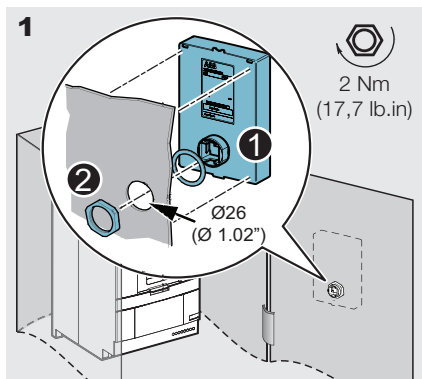
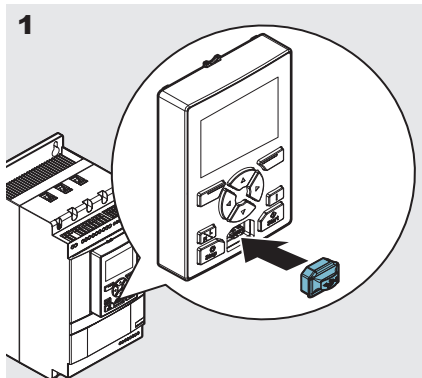


### CAUTION

Always make sure that the power supply is switched off before doing maintenance on the Softstarter.



### PSTX30...370



## Contact us

ABB AB  
Control Products  
Low voltage Products

SE-721 61 Västerås, Sweden  
Telephone: +46 (0) 21 32 50 00

[www.abb.com/lowvoltage](http://www.abb.com/lowvoltage)

© Copyright 2015, All rights reserved.  
Specification subject to change without notice.

Softstarter Type PSTX30...370, Spare part, 1SFC132098M0201, 2015-06-17, ABB AB, Control Products

Power and productivity  
for a better world™ **ABB**

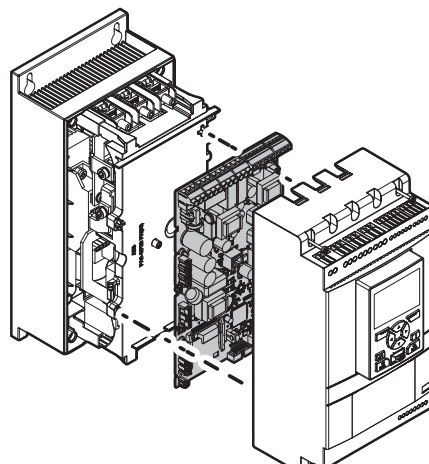


Installation Instruction

# Replace the softstarter PCBA

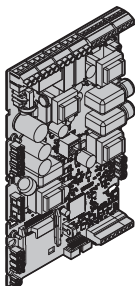
## PSTX30...370

Replace the PCBA

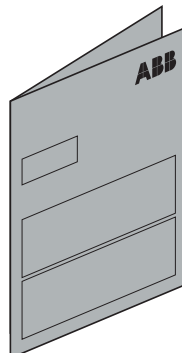


1SFA899300R1021 - PCBA

1x



1x



## Safety information



**Important information:** A qualified electrician must carry out installation, commissioning and service on the product by following installation standards and regulations. The product use hazardous voltage that can cause death or serious injury. Always disconnect power before working on equipment. Do not touch terminals when voltage is applied, output terminals can have live voltage even when the device is in off position. The product should only be used within the specified ratings. Check that you have the correct product in regards to mains voltage, supply voltage and rated product data.



**Viktig information:** Installation, idrifttagning och service av denna produkt skall endast utföras av behörig el-personal. Säkerhets- och installationsnormer skall följas. Produkten använder livsfarlig spänning, innan arbete utförs ska alltid spänningen frånskiljas. Rör inga anslutningar när produkten är spänningssatt, anslutningarna är spänningssatta även när produkten är i frånläge. Produkten skall endast användas inom dess specificerade data, kontrollera den gentemot huvudspänning, kontrollspänning och övriga märkdata.



**Wichtige Information:** Installation, Inbetriebnahme und Service dieses Produktes darf nur durch qualifiziertes Fachpersonal unter Beachtung der nachfolgenden Hinweise und Erklärungen erfolgen. Die in dem Gerät vorhandenen Spannungen können bei Berührung zu tödlichen oder ernsthaften Verletzungen führen. Vor Arbeiten an dem Gerät ist grundsätzlich die Versorgung abzuschalten. Bei Anliegen der Versorgungsspannung dürfen keine Klemmen berührt werden, an den Ausgangsklemmen kann auch bei ausgeschaltetem Gerät eine gefährliche Spannung anliegen. Der Einsatz des Gerätes darf nur innerhalb der spezifizierten Bedingungen erfolgen. Überprüfen Sie vor Einsatz, dass die Gerätetype bezüglich Versorgungsspannung, Schaltspannung und sonstiger Daten den Anforderungen entspricht.



**Informazioni importanti:** L'installazione, la messa in servizio e la manutenzione di questo prodotto devono essere effettuate solo da un elettricista qualificato, seguendo fedelmente le disposizioni in materia di installazione e sicurezza. Il prodotto utilizza tensioni pericolose che possono causare gravi danni o morte. Scollegare sempre l'alimentazione prima di accedere all'apparecchio. Non toccare mai i terminali quando l'apparecchio è sotto tensione: i terminali di uscita sono in tensione anche quando l'apparecchio è SPENTO. Prima dell'installazione; verificare di aver scelto il prodotto corretto specialmente in termini di tensione di alimentazione, principale ed ausiliaria, ma più in generale per tutte le caratteristiche tecniche. Il prodotto va utilizzato solo nelle condizioni specificate.



**重要信息：**产品的安装、调试及运行必须由具备资质的专业电工遵照相关标准及安全规范完成。产品使用能致命或引起严重伤害的危险电压。在产品上进行操作时务必断开电源。通电时不可接触接线端子，产品关闭后输出端子仍有电压。产品仅能按照规定额定值使用。检查主回路电压、控制回路电压及其它产品参数符合产品规定。



**Informations importantes:** Un électricien qualifié doit exécuter l'installation, la mise en service et l'entretien de ce produit en suivant les normes d'installation et les règles de sécurité. Le produit utilise une tension dangereuse qui peut causer la mort ou des blessures graves. Toujours débrancher l'alimentation avant de travailler sur l'équipement. Ne touchez pas les prises de raccordements lorsqu'une tension est appliquée, les prises de raccordements de sortie auront toujours une tension résiduelle, même si l'appareil est sur OFF. Le produit doit être seulement utilisé dans les calibres spécifiés. Vérifiez que vous avez le bon produit en ce qui concerne la tension du secteur, la tension d'alimentation nominale et les données produits.



**Важная информация:** Ус тановка, ввод в эксплуатацию и обслуживание данного оборудования должны производиться квалифицированным персоналом, специально допущенным к таким работам, в соответствии с действующим законодательством и требованиями предъявляемыми к обслуживанию электроустановок и обеспечению безопасности. В изделии используется опасное для человека напряжение, которое может привести к смерти или серьезным травмам. Всегда отключайте напряжение перед началом любых работ на оборудовании. Не дотрагивайтесь до клемм и токоведущих частей когда приложено напряжение. На выходных клеммах может быть напряжение даже если прибор выключен. Прибор должен использоваться строго в соответствии с заявленными параметрами. Проверьте, что прибор подобран правильно и номинальные параметры находятся в соответствии с силовым напряжением и напряжением управления.



**تحذير:** يسمح فقط للفني أو المهندس الكهربائي المختص للقيام بأعمال التثبيت و التجهيز و الصيانة لهذا النوع من الاجهزة وذلك من خلال اتباع انظمة التوصيل والتثبيت الكهربائية العالمية وشروط السلامة المعتمدة. هذا النوع من الاجهزة يستخدم جهد خطر قد يؤدي لحدوث الاصابة أو الوفاة . دائما افصل مصدر التيار قبل بدء العمل على الجهاز . لاتلمس أطراف التوصيل عندما يكون هنالك جهد مطبق لأن مخارج أطراف التوصيل تحتفظ بلاجهد حتى بعد فصل مصدر الجهد. هذا الجهاز يجب استخدامه مع ما يناسبه من قيم محددة . تأد دائما من حصولك على الجهاز المناسب لمصدر الفولتية والتردد والقيم المحددة للتيار .

# Installation Instruction - Replace the PCBA

## General

For complete information, see 1SFC132406M0201 - Softstarter PSRC10, Installation and commissioning manual available on: <https://solutions.abb/softstarters>



## WARNING

When performing maintenance on the Softstarter, an antistatic strap must be used. The antistatic strap should be worn on the wrist, and be connected to an electrical ground, to prevent electrostatic discharge (ESD) damage to the Softstarter.

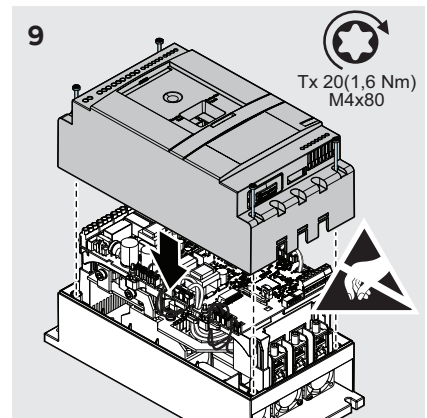
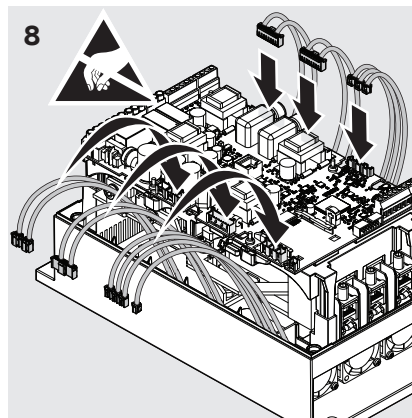
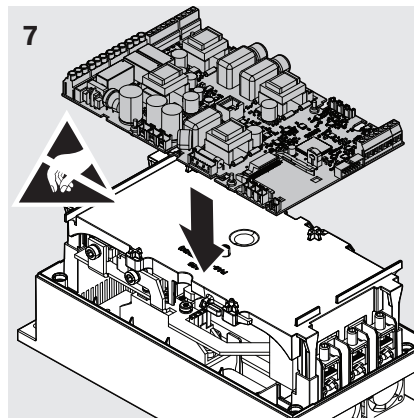
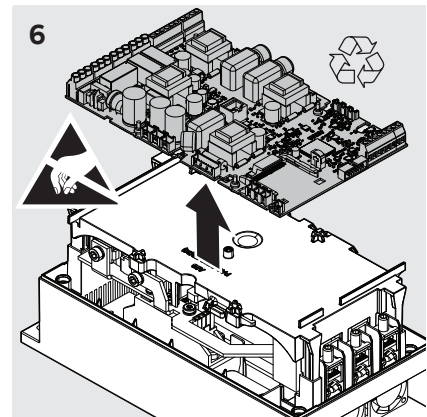
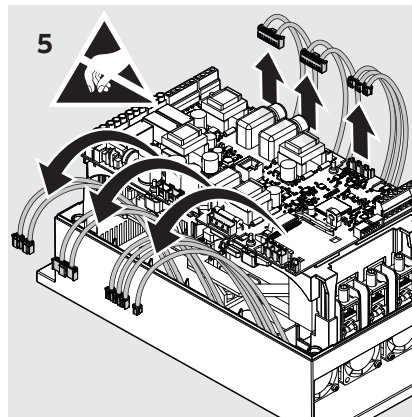
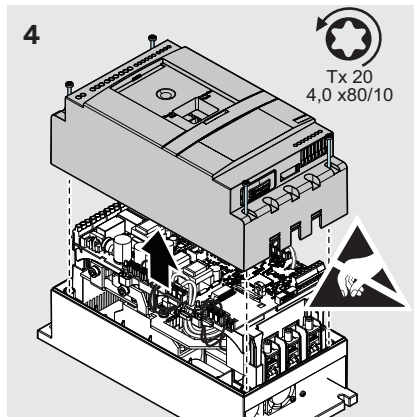
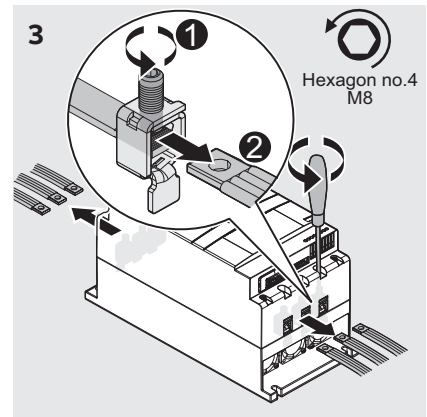
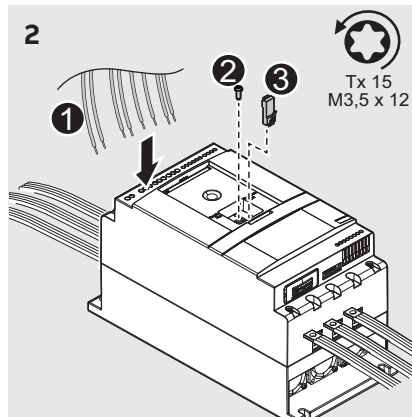
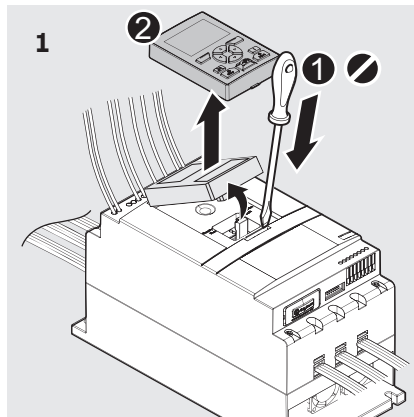


## CAUTION

Always make sure that the power supply is switched off before carrying out installation or maintenance on the Softstarter.



Service and repair should be performed by authorized personnel only. Note that unauthorized repair affects safety and warranty.



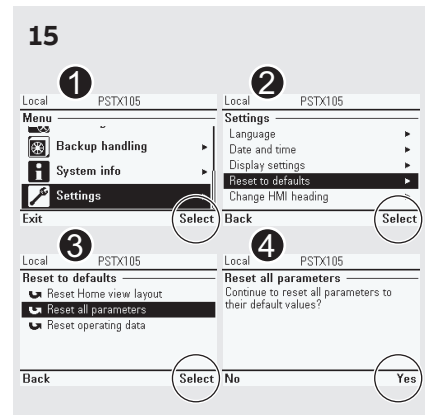
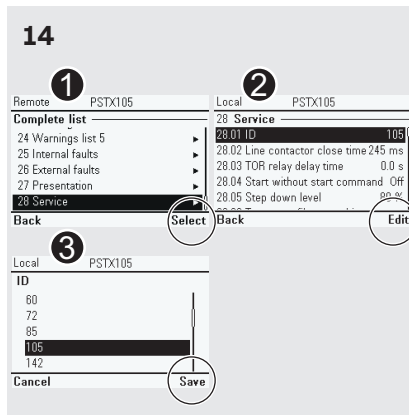
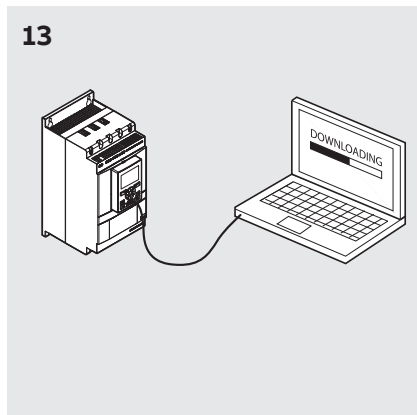
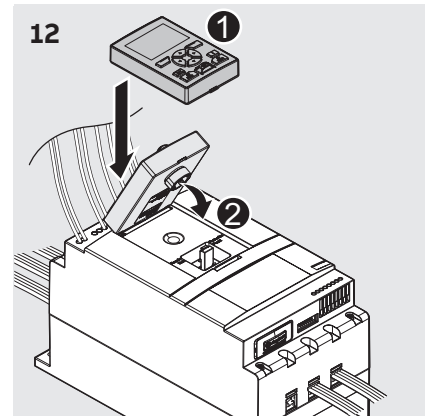
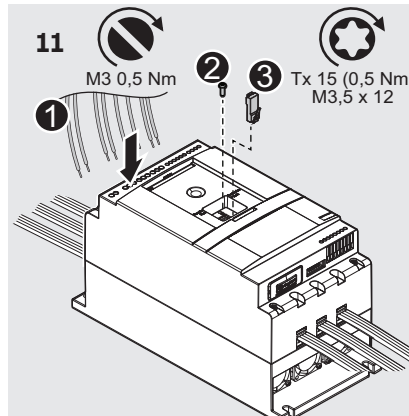
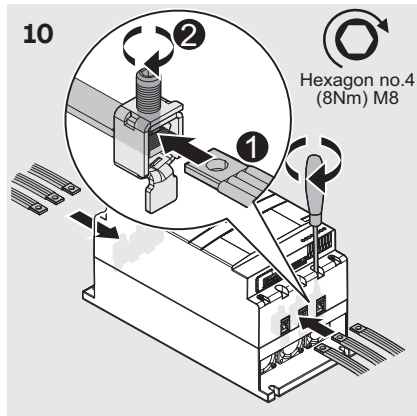
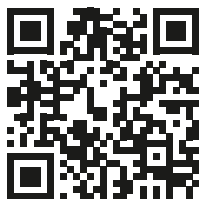


ABB Electrification Sweden AB  
**Smart Power - Motor Starting & Safety**  
 SE-721 61 Västerås  
 Sweden  
 E-mail: sales@se.abb.com

<https://solutions.abb/softstarters>



### Procedures after PCBA replacement

Firmware needs to be updated when changing the PCBA. Please contact your ABB sales office for information. See **Figure 13**.

Set the ID of the Softstarter after changing the PCBA. Changing the ID parameter will result in all le parameters being set to their default value followed by a restart of the device.

# Softstarter type PSTX30...1250

## Spare part instruction - Replace the fan

1SFC132108M0201 December 2015

Rev A

EN | Spare part instruction

| Softstarter type PSTX30...1250

| Replace the fan

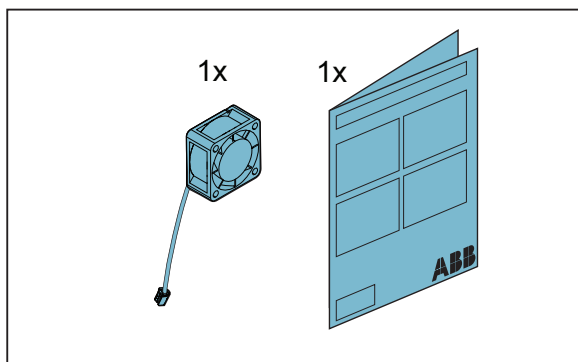
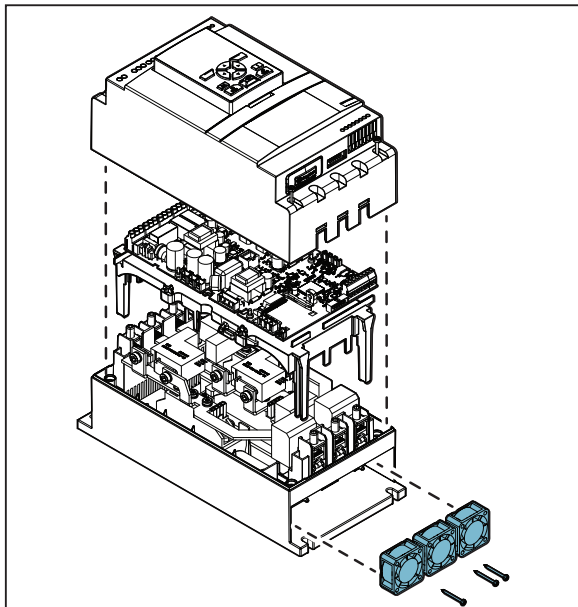
### General

For complete information, see 1SFC132081M0201 - Softstarters Type PSTX30...PSTX1250, Installation and Commissioning Manual available on: <http://www.abb.com/lowvoltage>

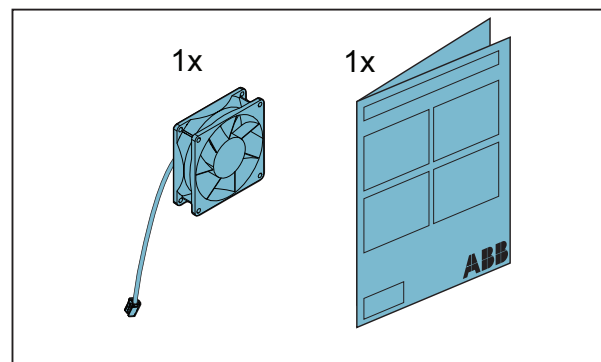
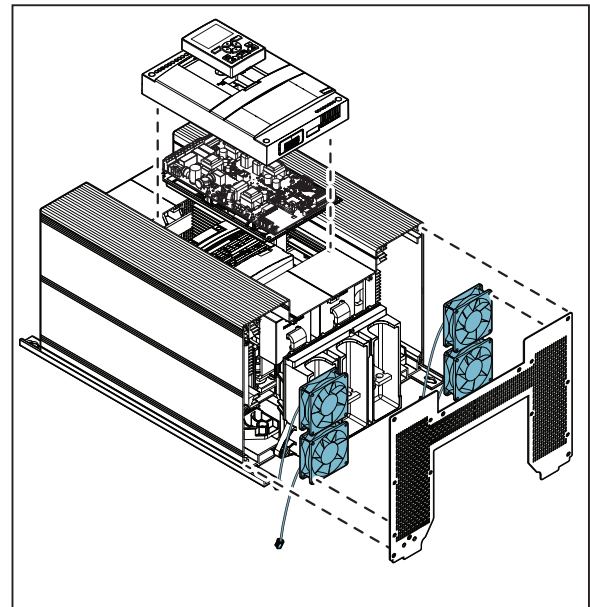


Service and repair should be performed by authorized personnel only. Note that unauthorized repair affects safety and warranty.

### 1. PSTX30...370 - Replace the fan



### 2. PSTX470...1250 - Replace the fan



Power and productivity  
for a better world™



## Safety information



**Warning!** A qualified electrician must carry out installation, commissioning and service on the product by following installation standards and regulations. The product user hazardous voltage that can cause death or serious injury. Always disconnect power before working on equipment. Do not touch terminals when voltage is applied, output terminals can have live voltage even when the device is in off position. The product should only be used within the specified ratings. Check that you have the correct product in regards to mains voltage, supply voltage and rated product data.



**Warning!** Installation, idrifttagning och service av denna produkt skall endast utföras av behörig el-personal. Säkerhets- och installationsnormer skall följas. Produkten använder livsfarlig spänning, innan arbete utförs ska alltid spänningen frånskiljas. Rör inga anslutningar när produkten är spänningssatt, anslutningarna är spänningssatta även när produkten är i frånläge. Produkten skall endast användas inom dess specificerade data, kontrollera den gentemot huvudspänning, kontrollspänning och övriga märkdata.



**Warnung!** Installation, Inbetriebnahme und Service dieses Produktes darf nur durch qualifiziertes Fachpersonal unter Beachtung der nachfolgenden Hinweise und Erklärungen erfolgen. Die in dem Gerät vorhandenen Spannungen können bei Berührung zu tödlichen oder ernsthaften Verletzungen führen. Vor Arbeiten an dem Gerät ist grundsätzlich die Versorgung abzuschalten. Bei Anliegen der Versorgungsspannung dürfen keine Klemmen berührt werden, an den Ausgangsklemmen kann auch bei ausgeschaltetem Gerät eine gefährliche Spannung anliegen. Der Einsatz des Gerätes darf nur innerhalb der spezifizierten Bedingungen erfolgen. Überprüfen Sie vor Einsatz, dass die Gerätype bezüglich Versorgungsspannung, Schaltspannung und sonstiger Daten den Anforderungen entspricht.



**Avvertenza!** L'installazione, la messa in servizio e la manutenzione di questo prodotto devono essere effettuate solo da un elettricista qualificato, seguendo fedelmente le disposizioni in materia di installazione e sicurezza. Il prodotto utilizza tensioni pericolose che possono causare gravi danni o morte. Scollegare sempre l'alimentazione prima di accedere all'apparecchio. Non toccare mai i terminali quando l'apparecchio è sotto tensione: i terminali di uscita sono in tensione anche quando l'apparecchio è SPENTO. Prima dell'istallazione; verificare di aver scelto il prodotto corretto specialmente in termini di tensione di alimentazione, principale ed ausiliaria, ma più in generale per tutte le caratteristiche tecniche. Il prodotto va utilizzato solo nelle condizioni specificate.



**警告!** 产品的安装、调试及运行必须由具备资质的专业电工遵照相关标准及安全规范完成。产品使用能致命或引起严重伤害的危险电压。在产品上进行操作时务必断开电源。通电时不可接触接线端子，产品关断后输出端子仍有电压。产品仅能按照规定额定值使用。检查主回路电压，控制回路电压及其它产品参数符合产品规定。



**Avertissement!** Un électricien qualifié doit exécuter l'installation, la mise en service et l'entretien de ce produit en suivant les normes d'installation et les règles de sécurité. Le produit utilise une tension dangereuse qui peut causer la mort ou des blessures graves. Toujours débrancher l'alimentation avant de travailler sur l'équipement. Ne techiez pas les prises de raccordements lorsqu'une tension est appliquée, les prises de raccordements de sortie auront toujours une tension résiduelle, même si l'appareil est sur OFF. Le produit doit être seulement utilisé dans les calibres spécifiées. Vérifiez que vous avez le bon produit en ce qui concerne la tension du secteur, la tension d'alimentation nominale et les données produits.

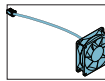


**Осторожно!** Установка, ввод в эксплуатацию и обслуживание данного оборудования должны производиться квалифицированным персоналом, специально допущенным к таким работам, в соответствии с действующим законодательством и требованиями предъявляемыми к обслуживанию электроустановок и обеспечению безопасности. В изделии используется опасное для человека напряжение, которое может привести к смерти или серьезным травмам. Всегда отключайте напряжение перед началом любых работ на оборудовании. Не затрагивайте до клемм и токоведущих частей когда приложено напряжение. На выходных клеммах может быть напряжение даже если прибор выключен. Прибор должен использоваться строго в соответствии с заявленными параметрами. Проверьте, что прибор подобран правильно и номинальные параметры находятся в соответствии с силовым напряжением и напряжением управления.



**تحذير!** يسمح فقط للفني أو المهندس الكهربائي المختص للقيام بأعمال التثبيت و التجهيز و الصيانة لهذا النوع من الاجهزة وذلك من خلال اتباع انظمة التوصيل والتثبيت الكهربائية العلامة وشروط السلامة المعتمدة. هذا النوع من الاجهزة يستخدم جهد خطر قد يؤدي لحدوث الاصابة أو الوفاة . دائما افصل مصدر التيار قبل بدء العمل على الجهاز . لاتلمس أطراف التوصيل عندما يكون هنالك جهد مطبق لأن مخارج أطراف التوصيل تحتفظ بلاجهد حتى بعد فصل مصدر الجهد. هذا الجهاز يجب استخدامه مع ما يناسبه من قيم محددة . تأد دائما من حصولك على الجهاز المناسب لمصدر الفولتية والتردد والقيم المحددة للتيار .

# 1. PSTX30...370 - Replace the fan



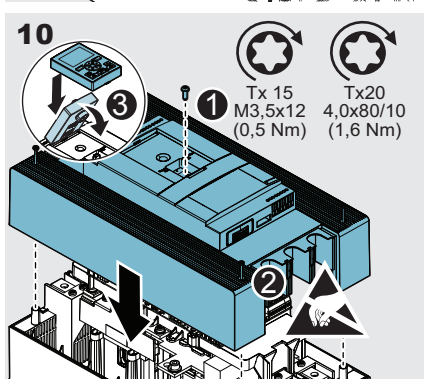
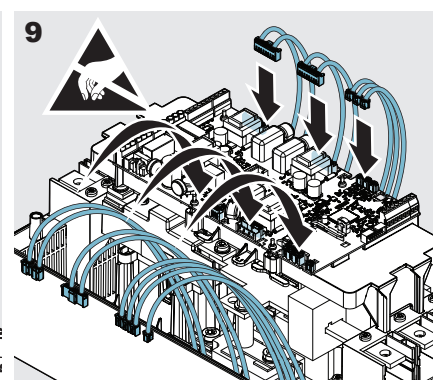
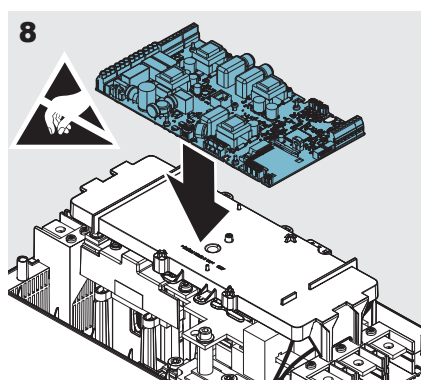
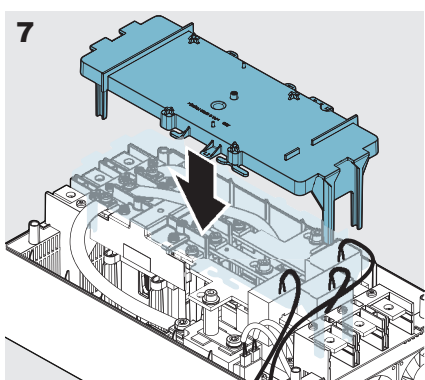
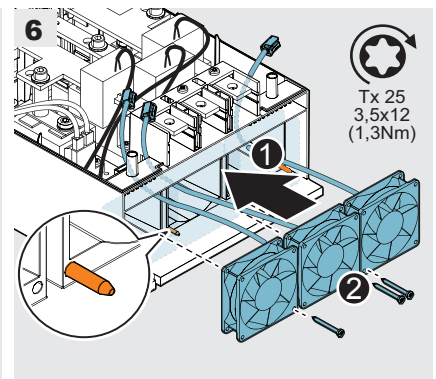
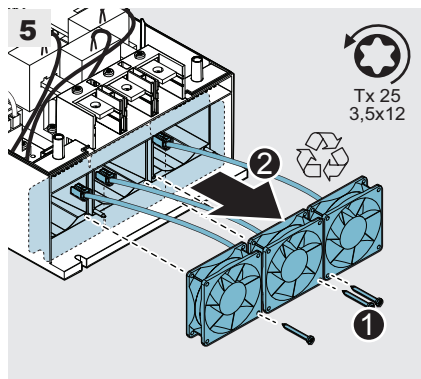
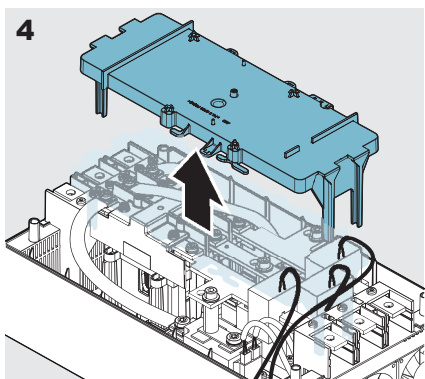
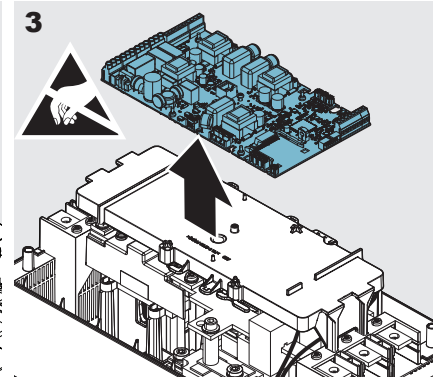
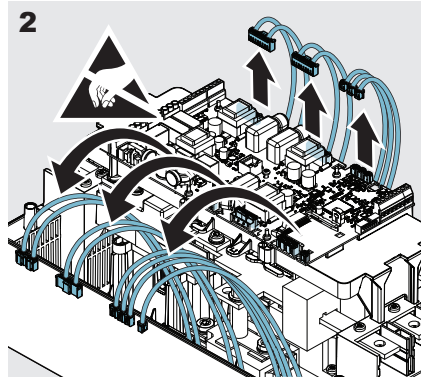
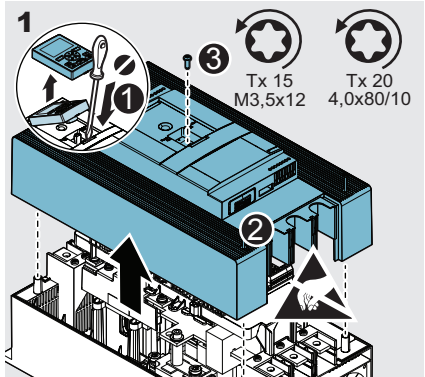
## WARNING

Always make sure that the power supply is switched off before doing maintenance on the Softstarter.

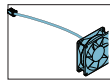


## WARNING

When performing maintenance on the Softstarter, an antistatic strap must be used. The antistatic strap should be worn on the wrist, and be connected to an electrical ground, to prevent electrostatic discharge (ESD) damage to the Softstarter.



## 2. PSTX470...1250 - Replace the fan



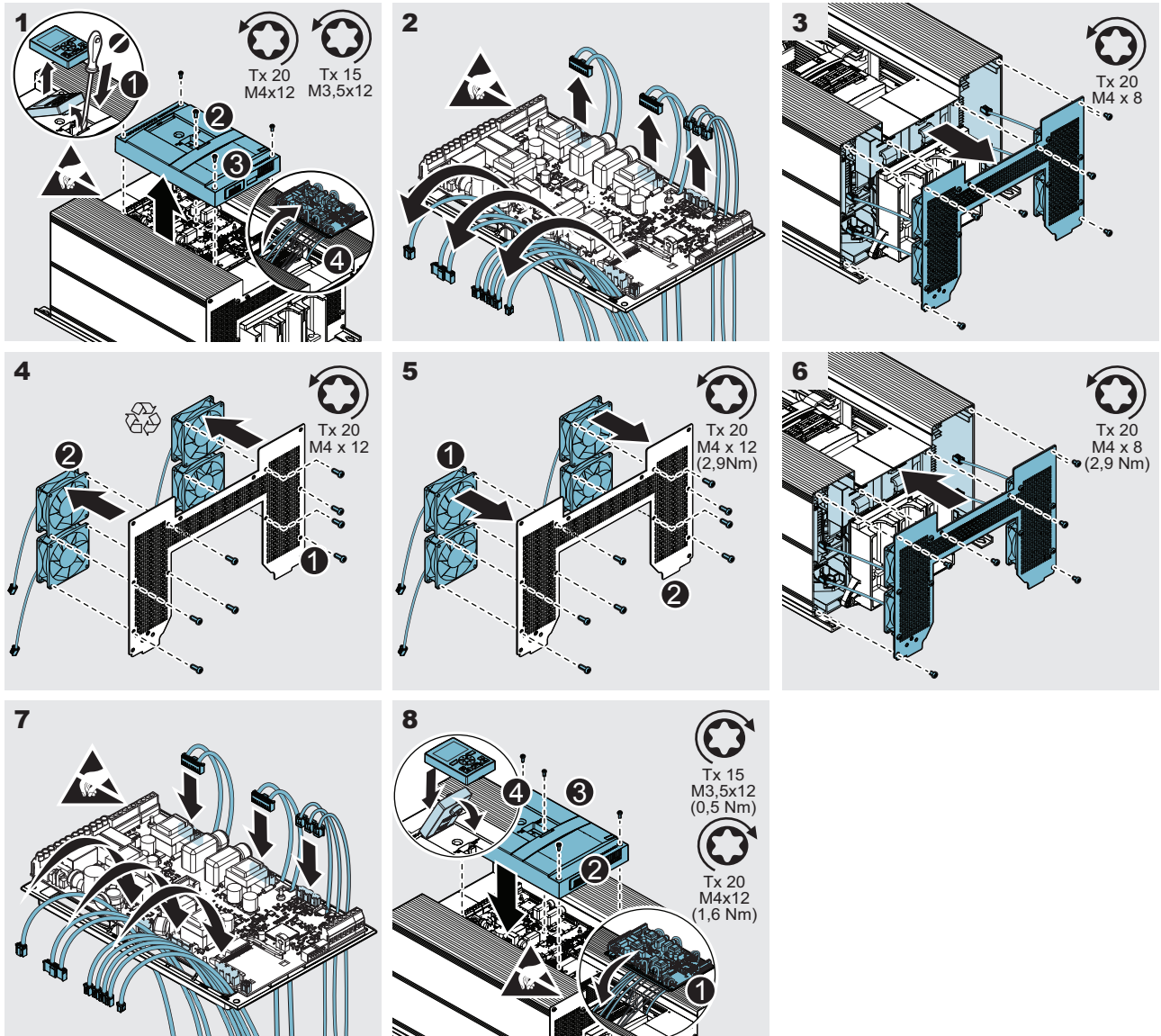
### WARNING

Always make sure that the power supply is switched off before doing maintenance on the Softstarter.



### WARNING

When performing maintenance on the Softstarter, an antistatic strap must be used. The antistatic strap should be worn on the wrist, and be connected to an electrical ground, to prevent electrostatic discharge (ESD) damage to the Softstarter.



Softstarter Type PSTX30...1250, Spare part instruction, 1SFC132108M0201 2015-12-07, ABB AB, Control Products

## Contact us

ABB AB  
 Control Products  
 Low voltage Products  
 SE-721 61 Västerås, Sweden  
 Telephone: +46 (0) 21 32 50 00  
[www.abb.com/lowvoltage](http://www.abb.com/lowvoltage)



# Softstarter type PSTX30...370

## Spare part instruction - Replace the plastic details

1SFC132112M0201 January 2016

Rev A

EN | Spare part instruction

| Softstarter type PSTX30...370

| Replace the plastic details

### General

For complete information, see 1SFC132081M0201 - Softstarters Type PSTX30...PSTX1250, Installation and Commissioning Manual available on: <http://www.abb.com/lowvoltage>



Service and repair should be performed by authorized personnel only. Note that unauthorized repair affects safety and warranty.

- Replace the bottom

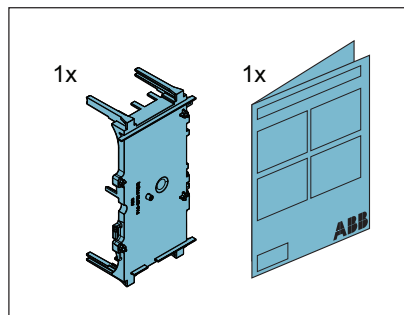
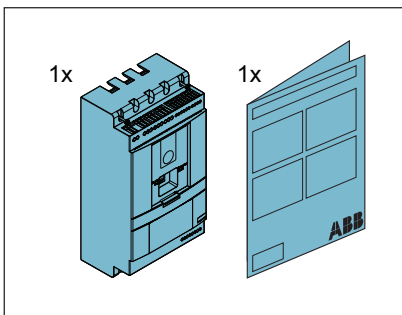
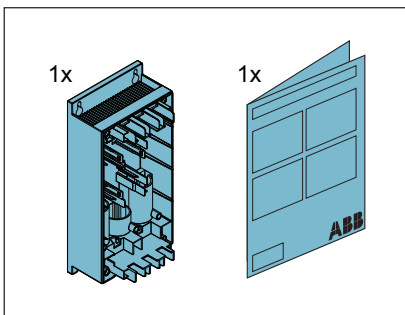
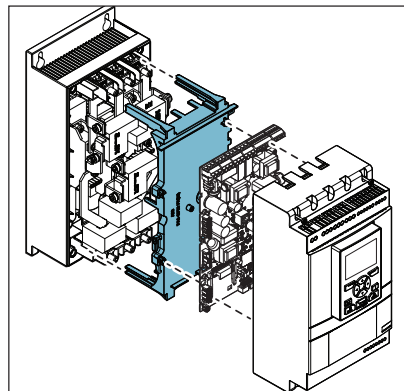
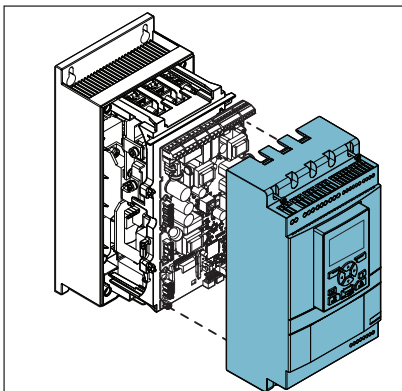
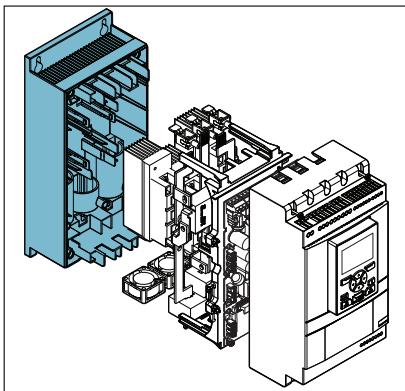
- 1. PSTX30...105**
- 4. PSTX142...170**
- 7. PSTX210...370**

- Replace the cover

- 2. PSTX30...105**
- 5. PSTX142...170**
- 8. PSTX210...370**

- Replace the CB bracket

- 3. PSTX30...105**
- 6. PSTX142...170**
- 9. PSTX210...370**



Power and productivity  
for a better world™



## Safety information



**Warning!** A qualified electrician must carry out installation, commissioning and service on the product by following installation standards and regulations. The product user hazardous voltage that can cause death or serious injury. Always disconnect power before working on equipment. Do not touch terminals when voltage is applied, output terminals can have live voltage even when the device is in off position. The product should only be used within the specified ratings. Check that you have the correct product in regards to mains voltage, supply voltage and rated product data.



**Warning!** Installation, idrifttagning och service av denna produkt skall endast utföras av behörig el-personal. Säkerhets- och installationsnormer skall följas. Produkten använder livsfarlig spänning, innan arbete utförs ska alltid spänningen frånskiljas. Rör inga anslutningar när produkten är spänningssatt, anslutningarna är spänningssatta även när produkten är i frånläge. Produkten skall endast användas inom dess specificerade data, kontrollera den gentemot huvudspänning, kontrollspänning och övriga märkdata.



**Warnung!** Installation, Inbetriebnahme und Service dieses Produktes darf nur durch qualifiziertes Fachpersonal unter Beachtung der nachfolgenden Hinweise und Erklärungen erfolgen. Die in dem Gerät vorhandenen Spannungen können bei Berührung zu tödlichen oder ernsthaften Verletzungen führen. Vor Arbeiten an dem Gerät ist grundsätzlich die Versorgung abzuschalten. Bei Anliegen der Versorgungsspannung dürfen keine Klemmen berührt werden, an den Ausgangsklemmen kann auch bei ausgeschaltetem Gerät eine gefährliche Spannung anliegen. Der Einsatz des Gerätes darf nur innerhalb der spezifizierten Bedingungen erfolgen. Überprüfen Sie vor Einsatz, dass die Gerätype bezüglich Versorgungsspannung, Schaltspannung und sonstiger Daten den Anforderungen entspricht.



**Avvertenza!** L'installazione, la messa in servizio e la manutenzione di questo prodotto devono essere effettuate solo da un elettricista qualificato, seguendo fedelmente le disposizioni in materia di installazione e sicurezza. Il prodotto utilizza tensioni pericolose che possono causare gravi danni o morte. Scollegare sempre l'alimentazione prima di accedere all'apparecchio. Non toccare mai i terminali quando l'apparecchio è sotto tensione: i terminali di uscita sono in tensione anche quando l'apparecchio è SPENTO. Prima dell'istallazione; verificare di aver scelto il prodotto corretto specialmente in termini di tensione di alimentazione, principale ed ausiliaria, ma più in generale per tutte le caratteristiche tecniche. Il prodotto va utilizzato solo nelle condizioni specificate.



**警告!** 产品的安装、调试及运行必须由具备资质的专业电工遵照相关标准及安全规范完成。产品使用能致命或引起严重伤害的危险电压。在产品上进行操作时务必断开电源。通电时不可接触接线端子，产品关断后输出端子仍有电压。产品仅能按照规定额定值使用。检查主回路电压，控制回路电压及其它产品参数符合产品规定。



**Avertissement!** Un électricien qualifié doit exécuter l'installation, la mise en service et l'entretien de ce produit en suivant les normes d'installation et les règles de sécurité. Le produit utilise une tension dangereuse qui peut causer la mort ou des blessures graves. Toujours débrancher l'alimentation avant de travailler sur l'équipement. Ne techiez pas les prises de raccordements lorsqu'une tension est appliquée, les prises de raccordements de sortie auront toujours une tension résiduelle, même si l'appareil est sur OFF. Le produit doit être seulement utilisé dans les calibres spécifiées. Vérifiez que vous avez le bon produit en ce qui concerne la tension du secteur, la tension d'alimentation nominale et les données produits.



**Осторожно!** Установка, ввод в эксплуатацию и обслуживание данного оборудования должны производиться квалифицированным персоналом, специально допущенным к таким работам, в соответствии с действующим законодательством и требованиями предъявляемыми к обслуживанию электроустановок и обеспечению безопасности. В изделии используется опасное для человека напряжение, которое может привести к смерти или серьезным травмам. Всегда отключайте напряжение перед началом любых работ на оборудовании. Не затрагивайте до клемм и токоведущих частей когда приложено напряжение. На выходных клеммах может быть напряжение даже если прибор выключен. Прибор должен использоваться строго в соответствии с заявленными параметрами. Проверьте, что прибор подобран правильно и номинальные параметры находятся в соответствии с силовым напряжением и напряжением управления.



**تحذير!** يسمح فقط للفني أو المهندس الكهربائي المختص للقيام بأعمال التثبيت و التجهيز و الصيانة لهذا النوع من الاجهزة وذلك من خلال اتباع انظمة التوصيل والتثبيت الكهربائية العلامة وشروط السلامة المعتمدة. هذا النوع من الاجهزة يستخدم جهد خطر قد يؤدي لحدوث الاصابة أو الوفاة . دائما افصل مصدر التيار قبل بدء العمل على الجهاز . لاتلمس أطراف التوصيل عندما يكون هناك جهد مطبق لأن مخارج أطراف التوصيل تحتفظ بلاجهد حتى بعد فصل مصدر الجهد. هذا الجهاز يجب استخدامه مع ما يناسبه من قيم محددة . تأد دائما من حصولك على الجهاز المناسب لمصدر الفولتية والتردد والقيم المحددة للتيار .

# 1. PSTX30...105

## - Replace the bottom



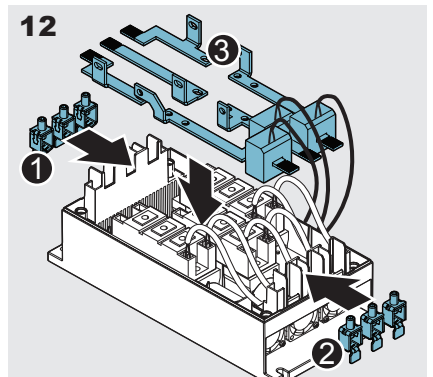
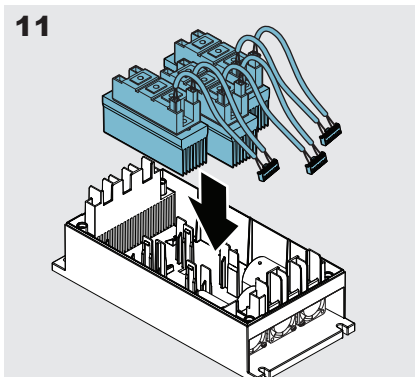
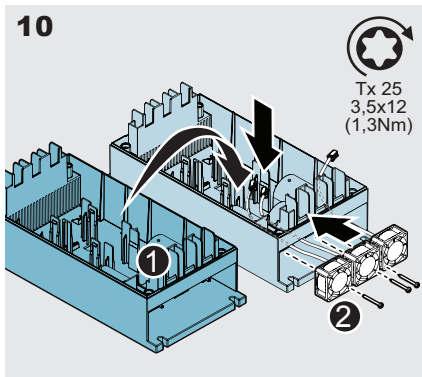
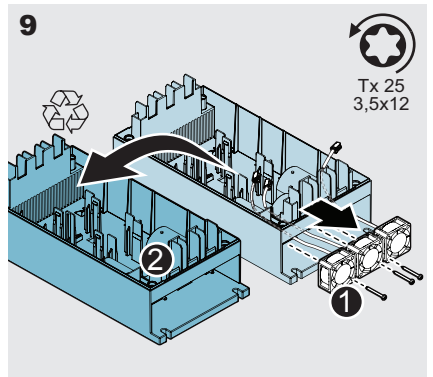
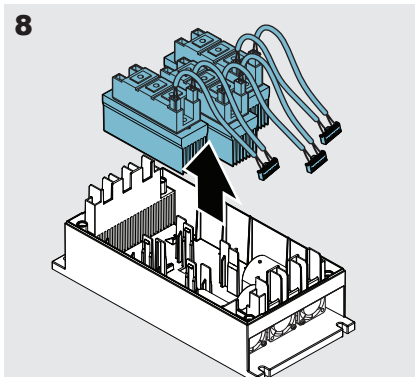
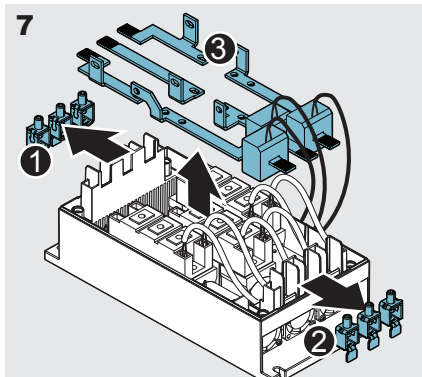
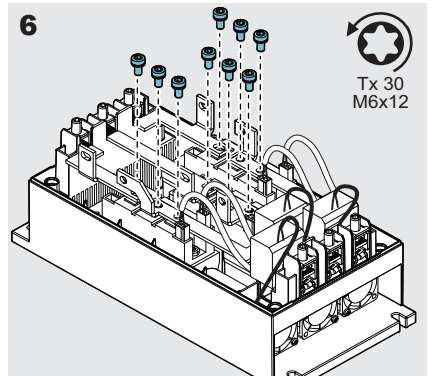
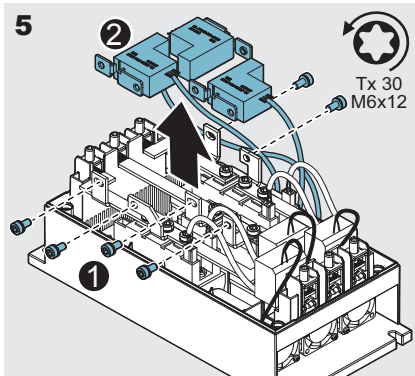
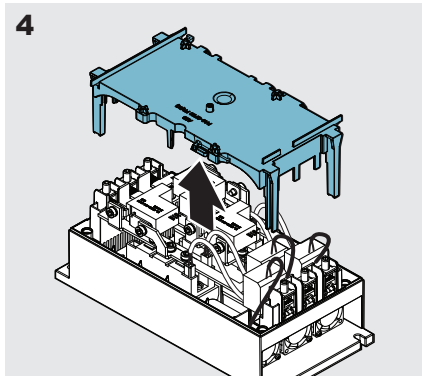
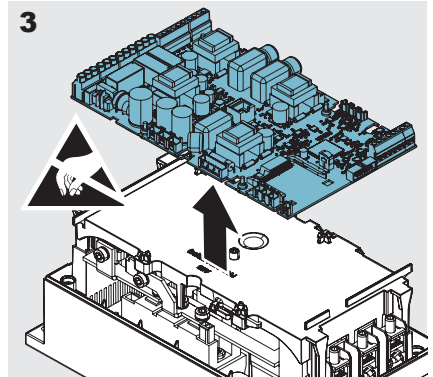
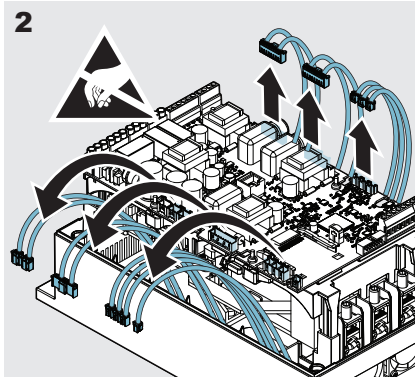
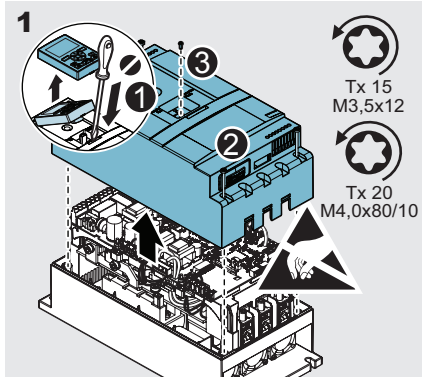
### WARNING

When performing maintenance on the Softstarter, an antistatic strap must be used. The antistatic strap should be worn on the wrist, and be connected to an electrical ground, to prevent electrostatic discharge (ESD) damage to the Softstarter.

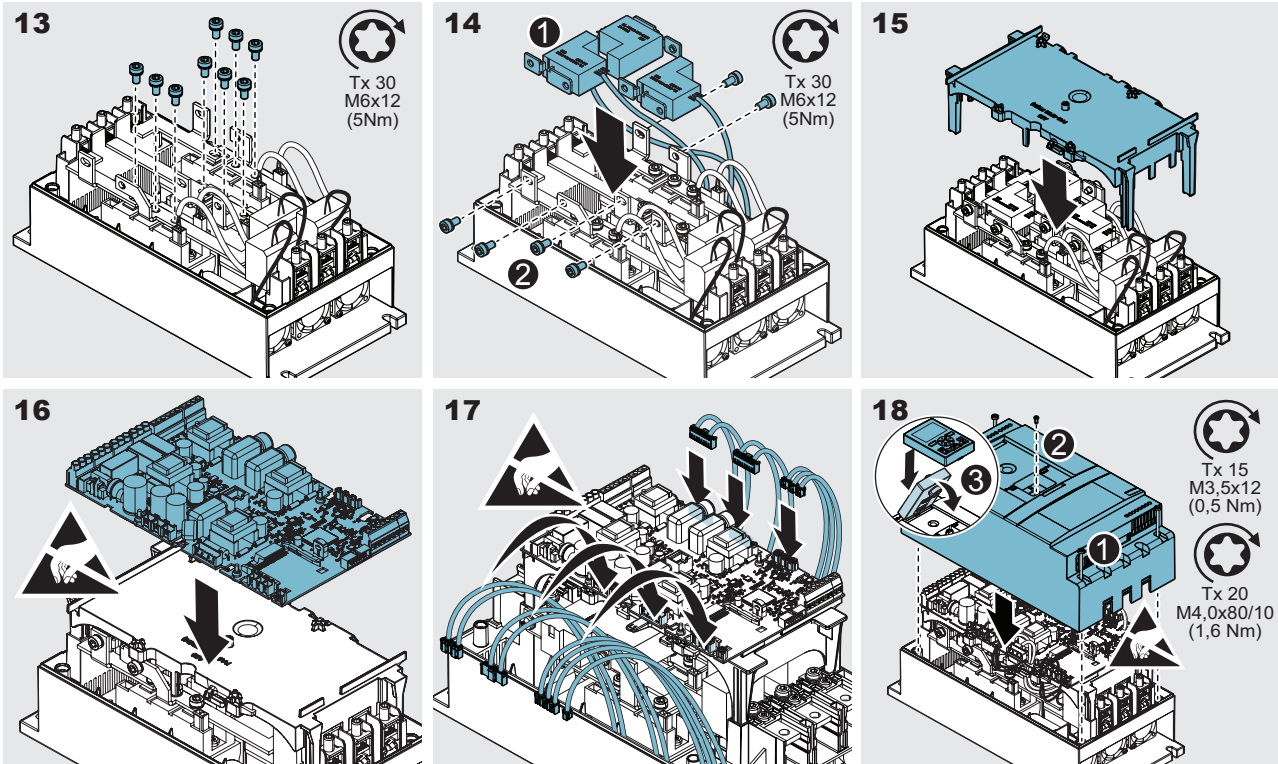


### WARNING

Always make sure that the power supply is switched off before doing maintenance on the Softstarter.



## 1. PSTX30...105 - Replace the bottom



## 2. PSTX30...105 - Replace the cover



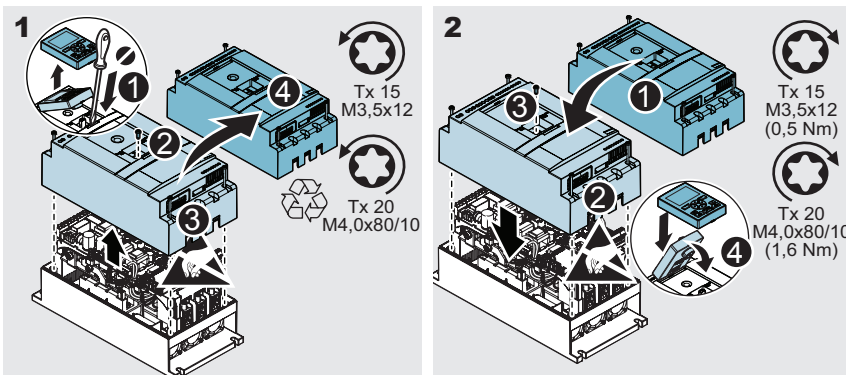
### WARNING

Always make sure that the power supply is switched off before doing maintenance on the Softstarter.

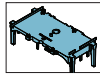


### WARNING

When performing maintenance on the Softstarter, an antistatic strap must be used. The antistatic strap should be worn on the wrist, and be connected to an electrical ground, to prevent electrostatic discharge (ESD) damage to the Softstarter.



### 3. PSTX30...105 - Replace the CB bracket



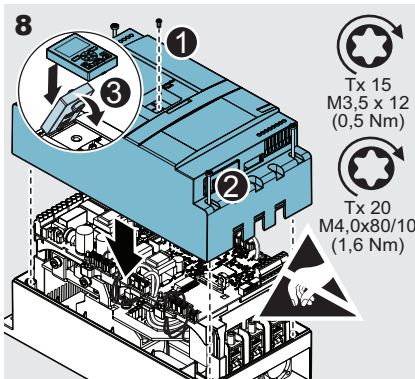
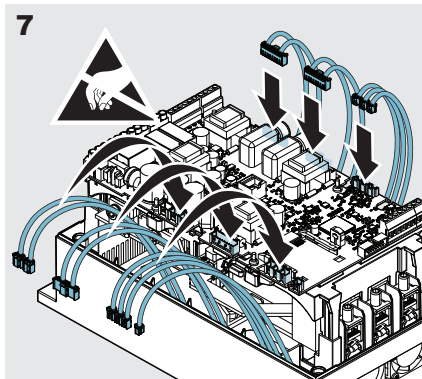
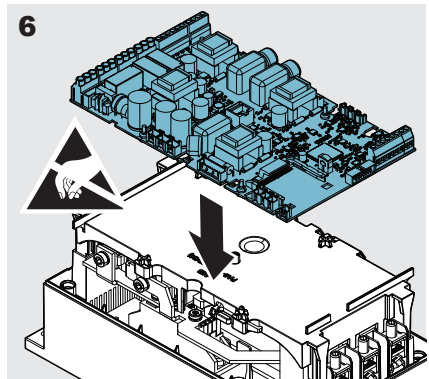
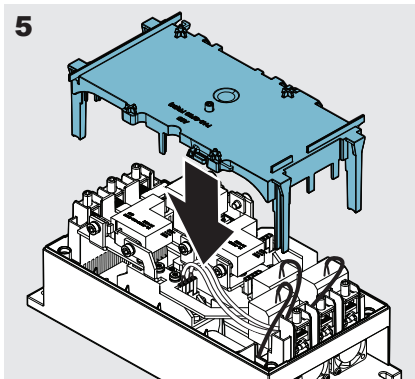
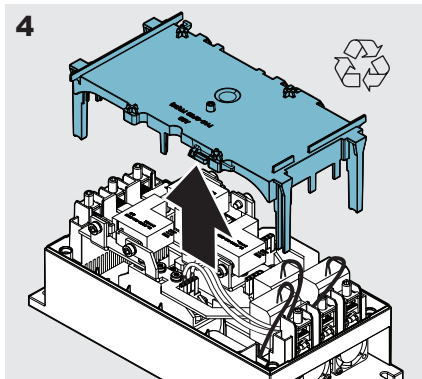
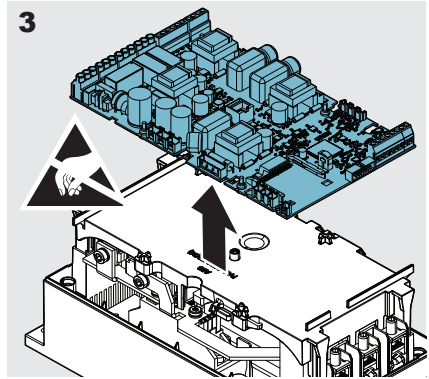
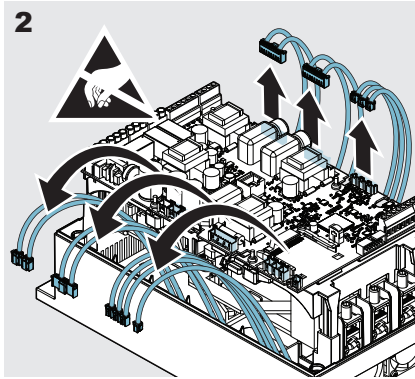
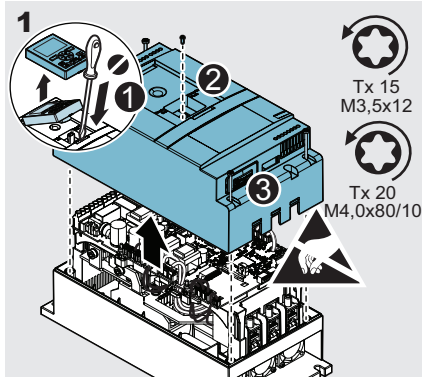
#### WARNING

When performing maintenance on the Softstarter, an antistatic strap must be used. The antistatic strap should be worn on the wrist, and be connected to an electrical ground, to prevent electrostatic discharge (ESD) damage to the Softstarter.

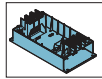


#### WARNING

Always make sure that the power supply is switched off before doing maintenance on the Softstarter.



## 4. PSTX142...170 - Replace the bottom



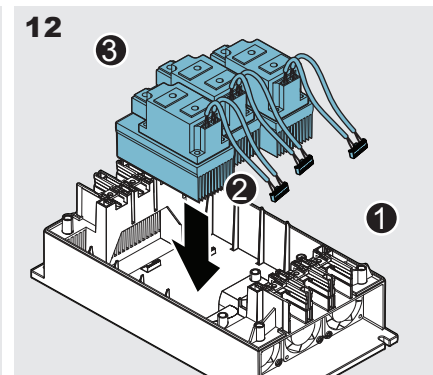
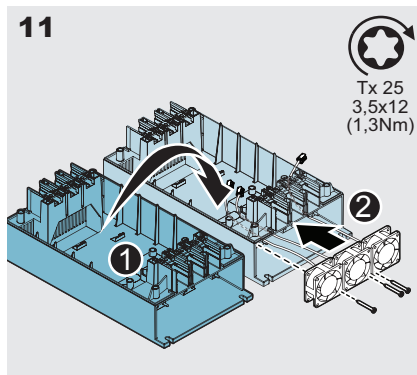
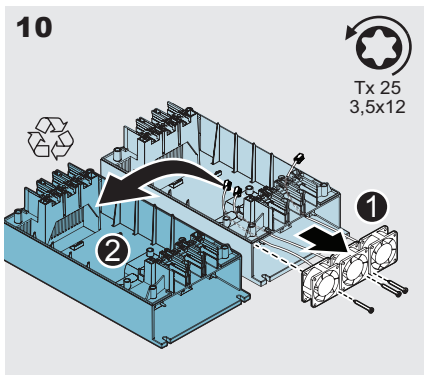
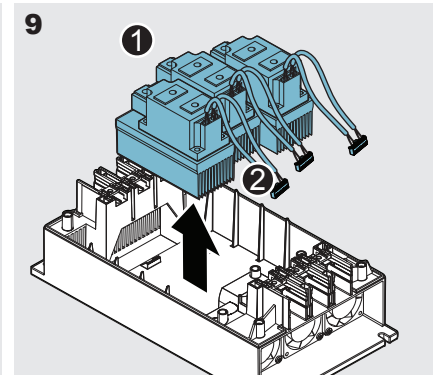
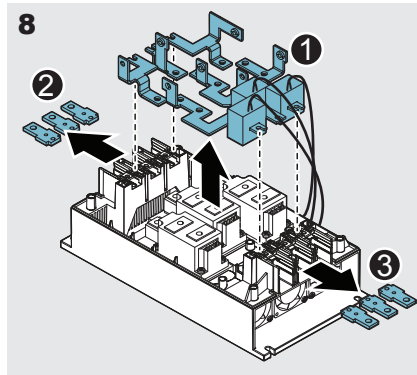
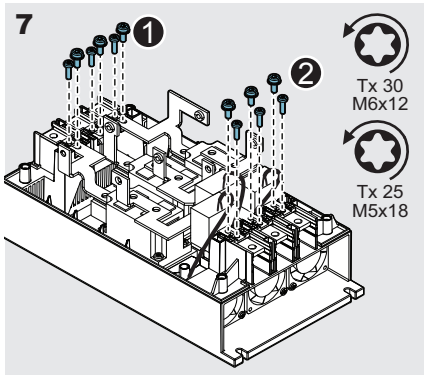
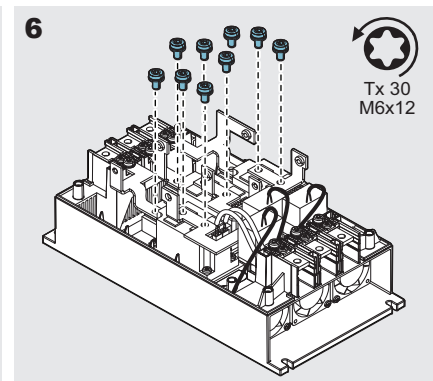
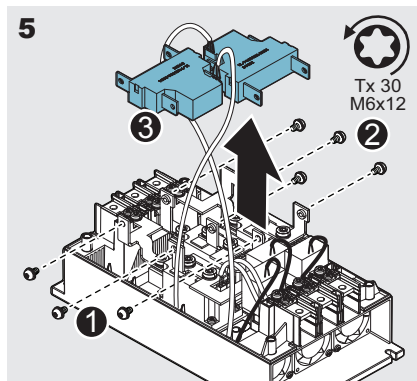
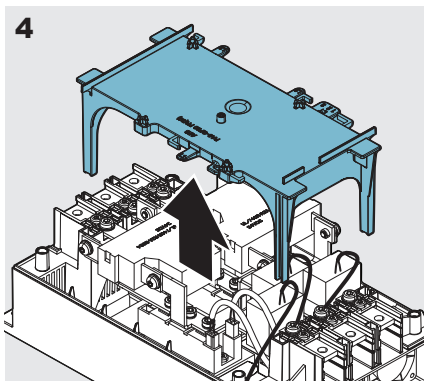
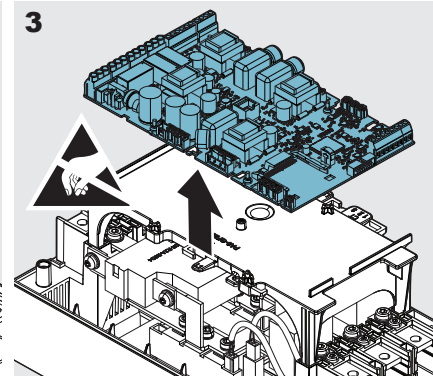
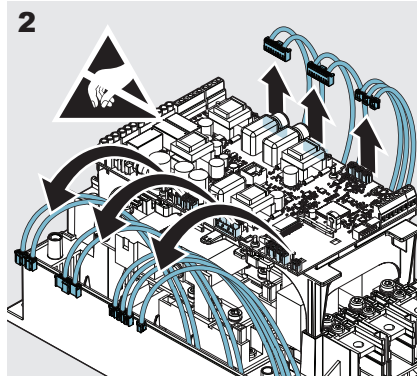
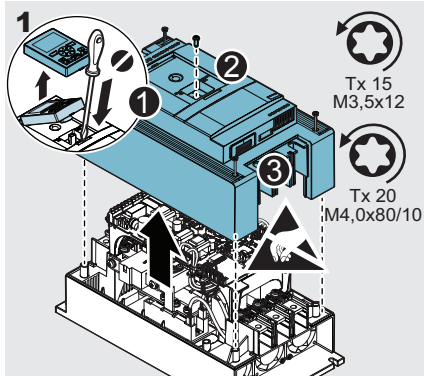
### WARNING

Always make sure that the power supply is switched off before doing maintenance on the Softstarter.

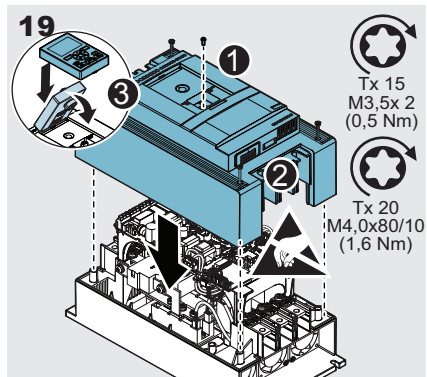
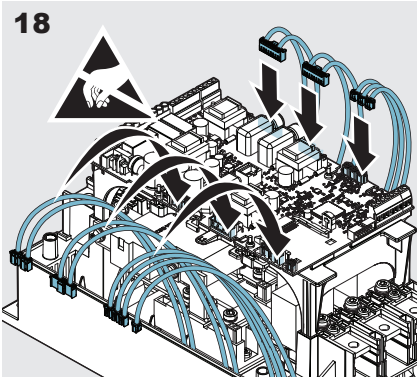
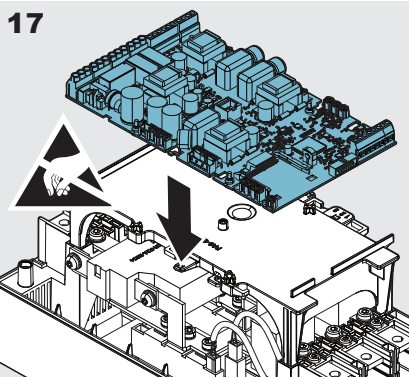
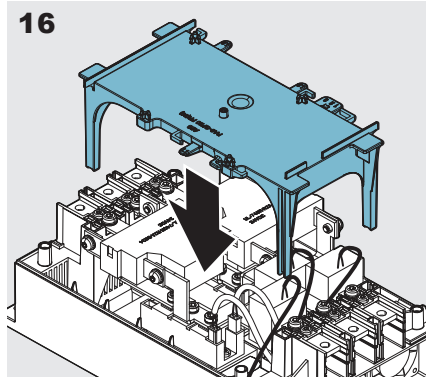
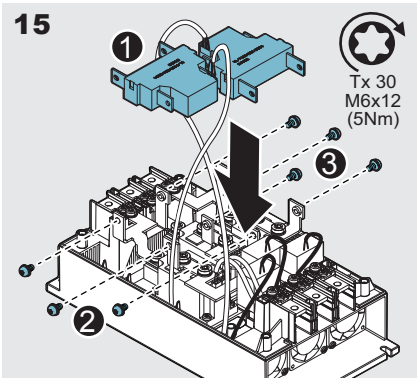
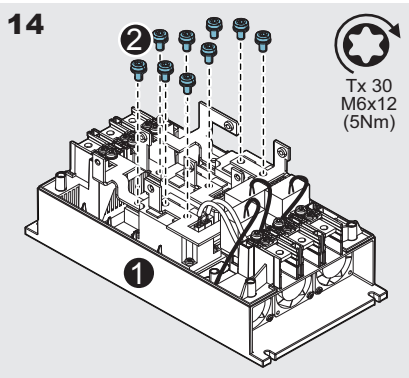
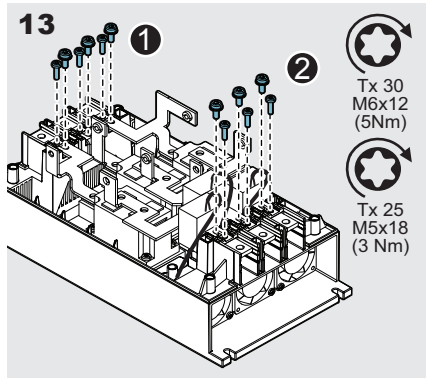


### WARNING

When performing maintenance on the Softstarter, an antistatic strap must be used. The antistatic strap should be worn on the wrist, and be connected to an electrical ground, to prevent electrostatic discharge (ESD) damage to the Softstarter.



## 4. PSTX142...170 - Replace the bottom

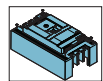


## 5. PSTX142...170 - Replace the cover



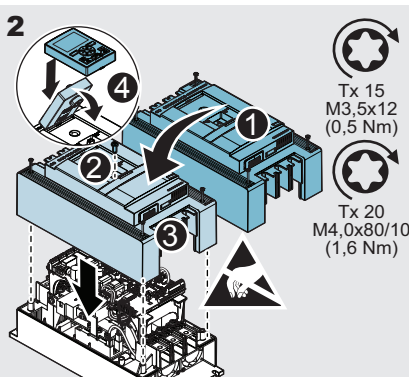
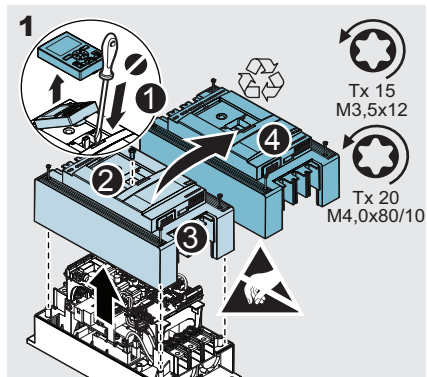
### WARNING

Always make sure that the power supply is switched off before doing maintenance on the Softstarter.



### WARNING

When performing maintenance on the Softstarter, an antistatic strap must be used. The antistatic strap should be worn on the wrist, and be connected to an electrical ground, to prevent electrostatic discharge (ESD) damage to the Softstarter.



## 6. PSTX142...170 - Replace the CB bracket



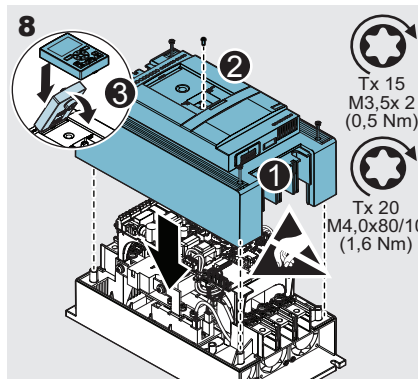
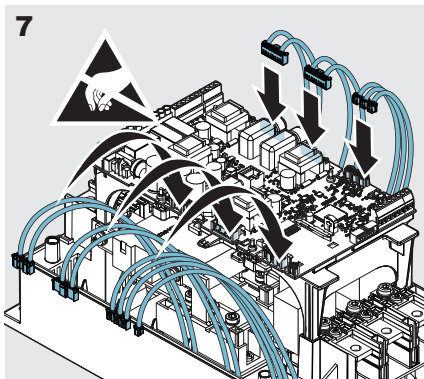
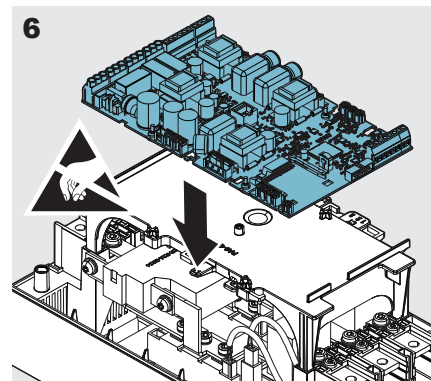
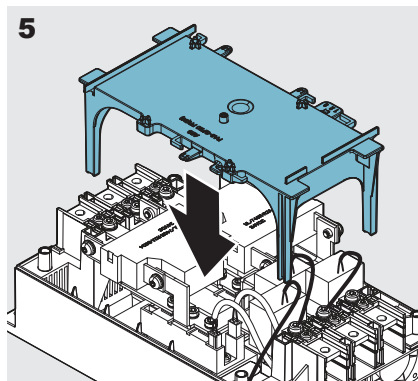
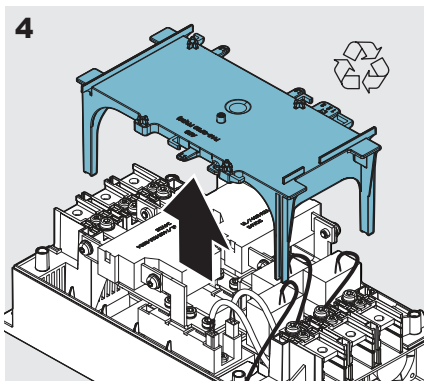
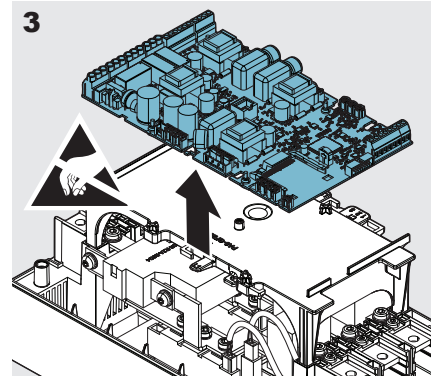
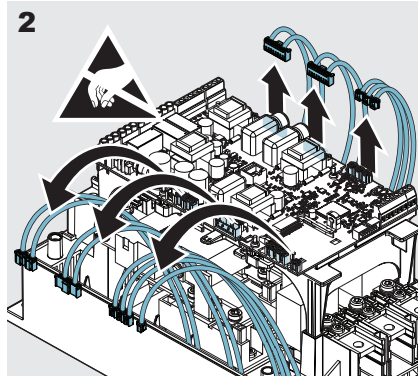
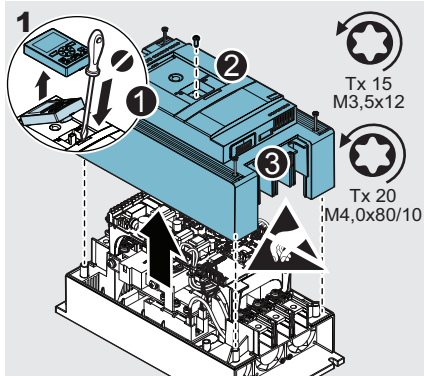
### WARNING

When performing maintenance on the Softstarter, an antistatic strap must be used. The antistatic strap should be worn on the wrist, and be connected to an electrical ground, to prevent electrostatic discharge (ESD) damage to the Softstarter.



### WARNING

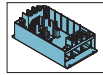
Always make sure that the power supply is switched off before doing maintenance on the Softstarter.





## 7. PSTX210...370

### - Replace the bottom



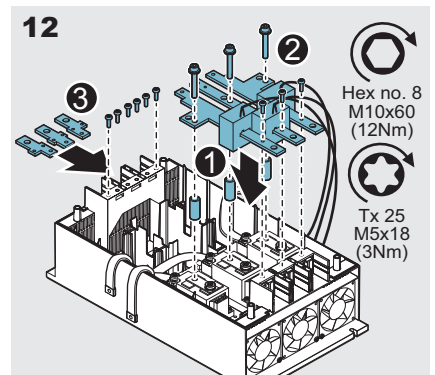
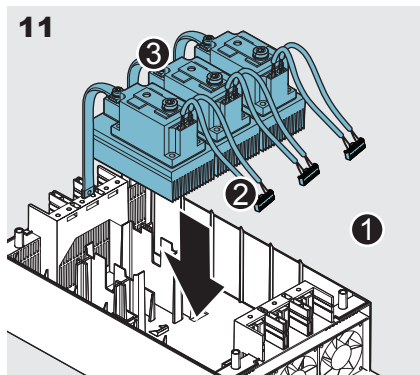
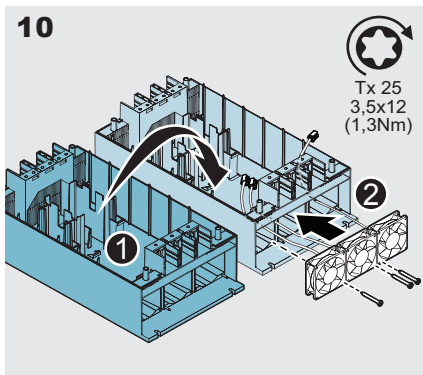
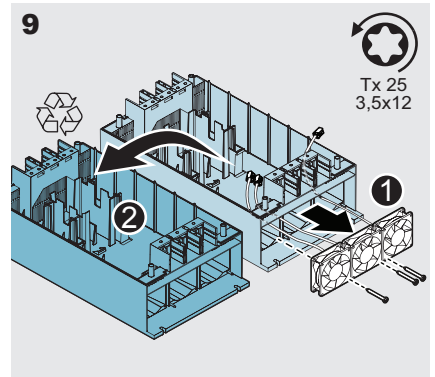
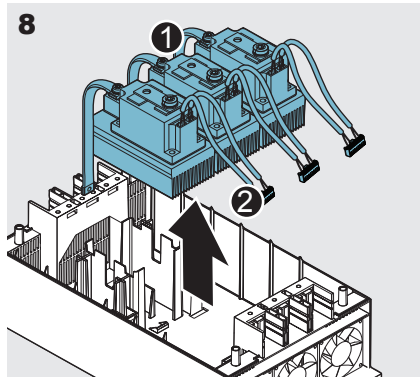
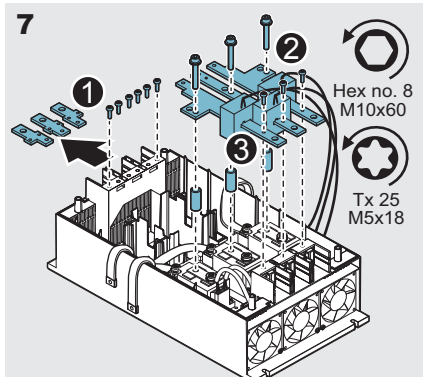
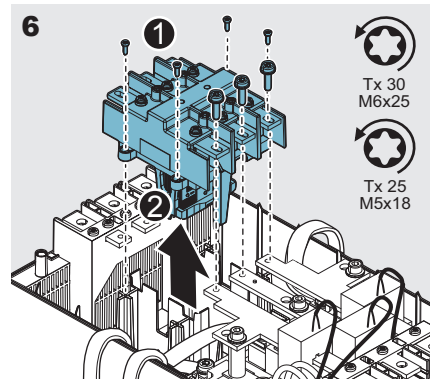
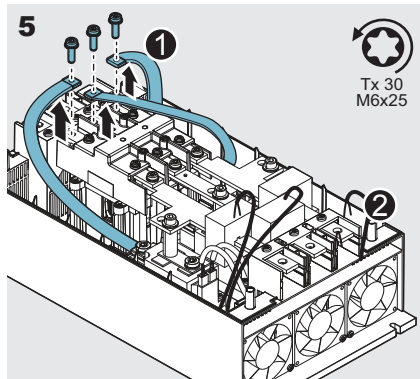
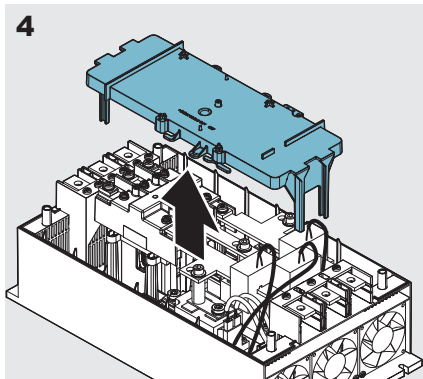
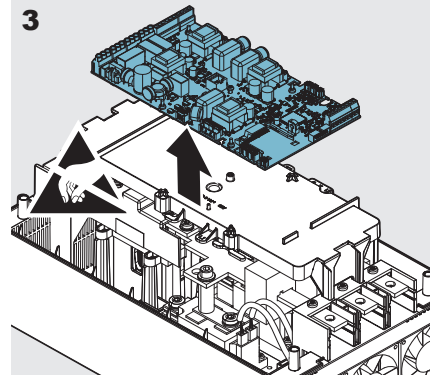
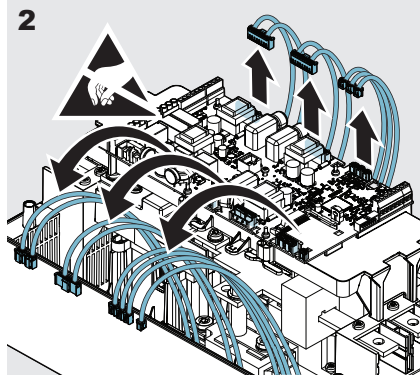
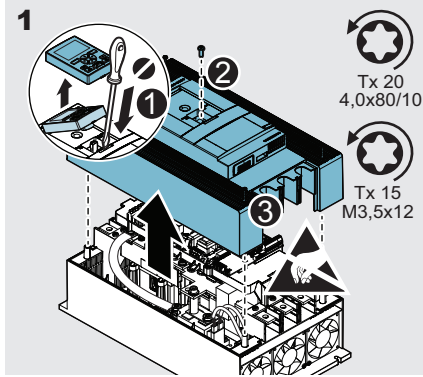
#### WARNING

When performing maintenance on the Softstarter, an antistatic strap must be used. The antistatic strap should be worn on the wrist, and be connected to an electrical ground, to prevent electrostatic discharge (ESD) damage to the Softstarter.

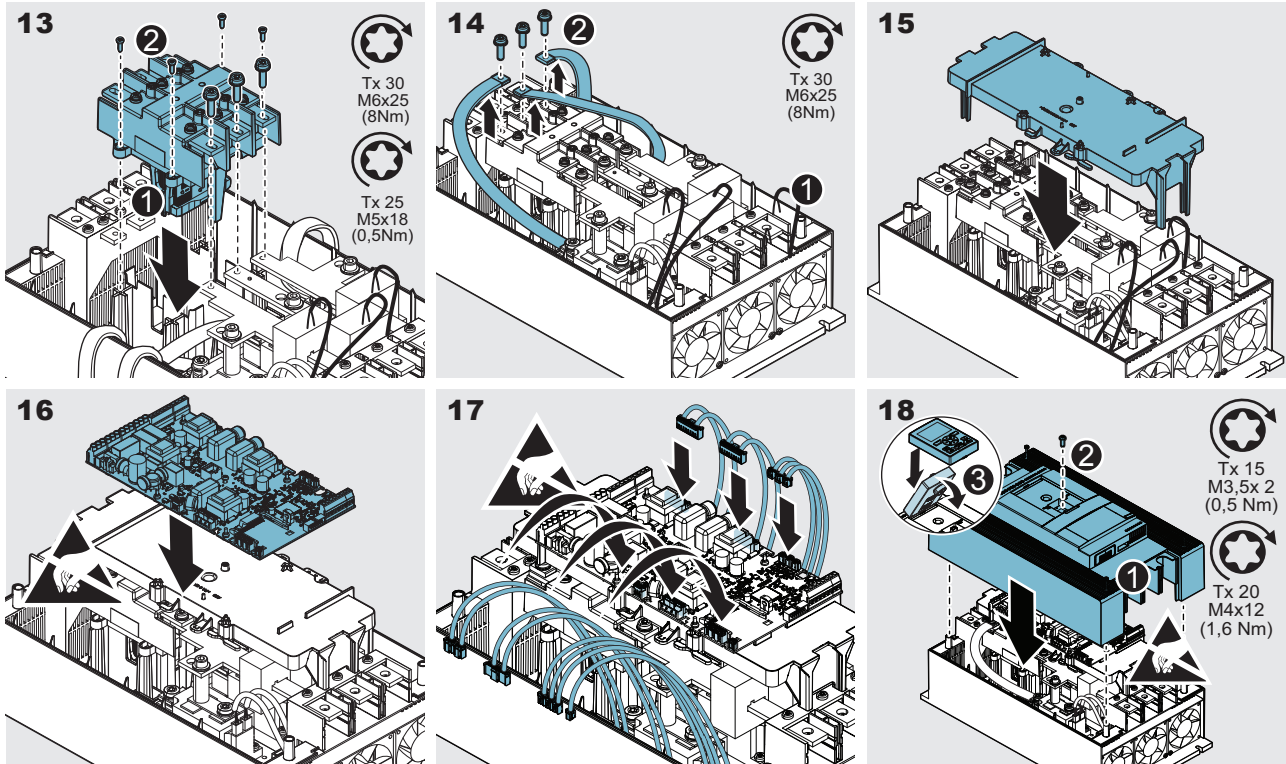
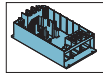


#### WARNING

Always make sure that the power supply is switched off before doing maintenance on the Softstarter.



## 7. PSTX210...370 - Replace the bottom



## 8. PSTX210...370 - Replace the cover



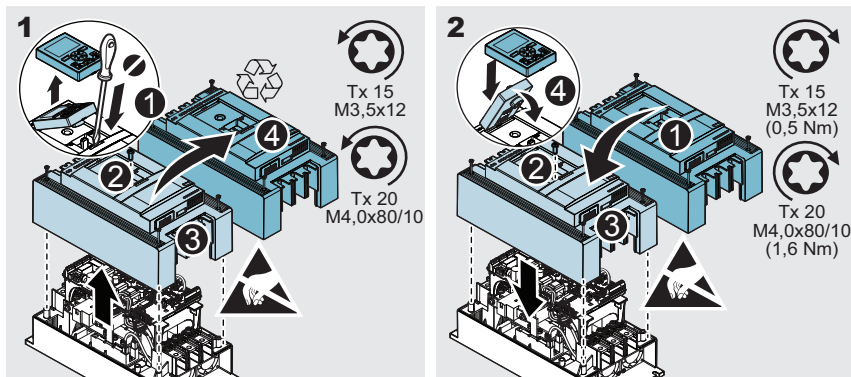
### WARNING

Always make sure that the power supply is switched off before doing maintenance on the Softstarter.



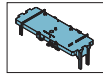
### WARNING

When performing maintenance on the Softstarter, an antistatic strap must be used. The antistatic strap should be worn on the wrist, and be connected to an electrical ground, to prevent electrostatic discharge (ESD) damage to the Softstarter.



## 9. PSTX210...370

### - Replace the CB bracket



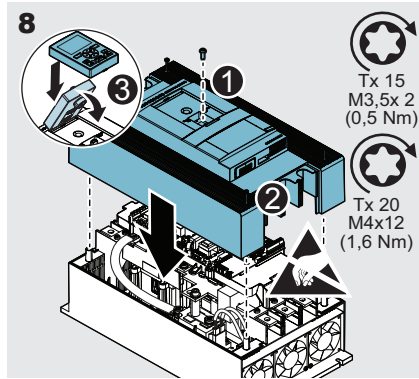
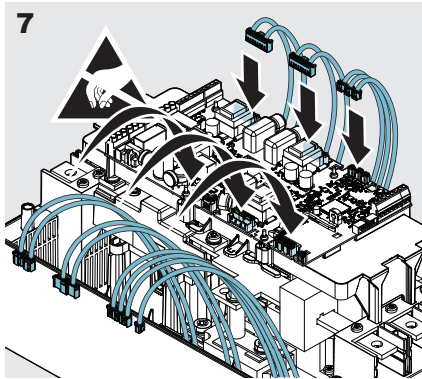
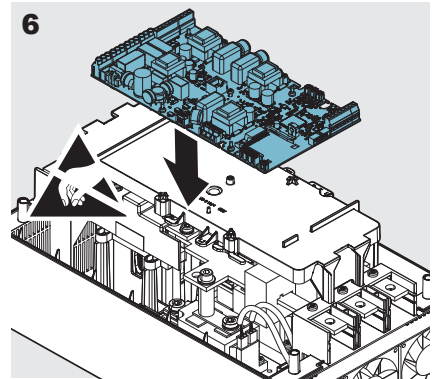
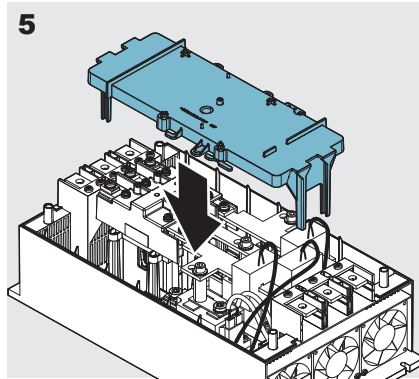
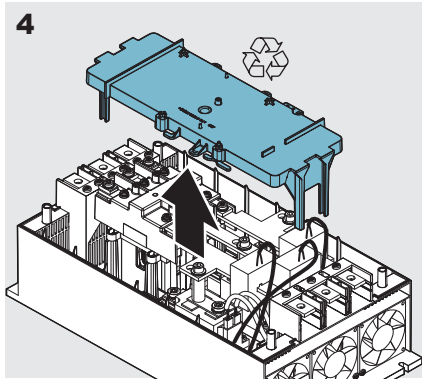
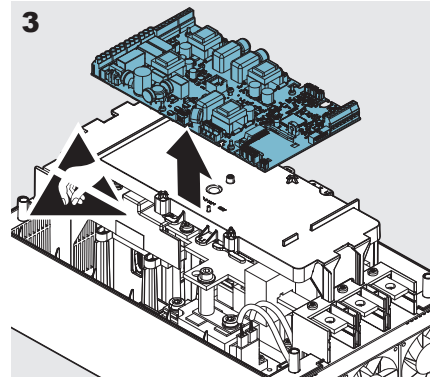
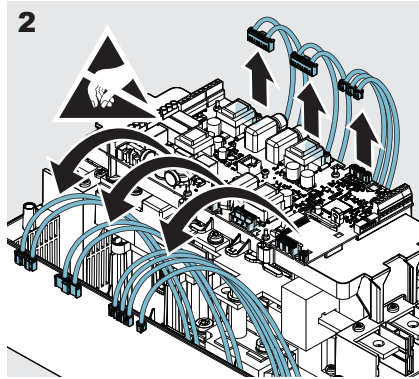
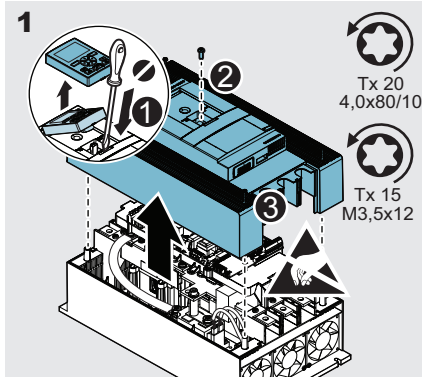
#### WARNING

Always make sure that the power supply is switched off before doing maintenance on the Softstarter.



#### WARNING

When performing maintenance on the Softstarter, an antistatic strap must be used. The antistatic strap should be worn on the wrist, and be connected to an electrical ground, to prevent electrostatic discharge (ESD) damage to the Softstarter.



# Contact us

**ABB AB**

**Control Products**

**Low voltage Products**

SE-721 61 Västerås, Sweden

Telephone: +46 (0) 21 32 50 00

**[www.abb.com/lowvoltage](http://www.abb.com/lowvoltage)**

Sofstarter Type PSTX30...370, Spare part instruction, 1SFC132112M0201, 2016-01-05, ABB AB, Control Products

# Softstarter type PSTX30...370

## Spare part instruction - Replace the bypass contactor

1SFC132109M0201 December 2015

Rev A

EN | Spare part instruction

| Softstarter type PSTX30...370

| Replace the bypass contactor

### General

For complete information, see 1SFC132081M0201 - Softstarters Type PSTX30...PSTX1250, Installation and Commissioning Manual available on: <http://www.abb.com/lowvoltage>

**i** Service and repair should be performed by authorized personnel only. Note that unauthorized repair affects safety and warranty.

### 1. PSTX30...105

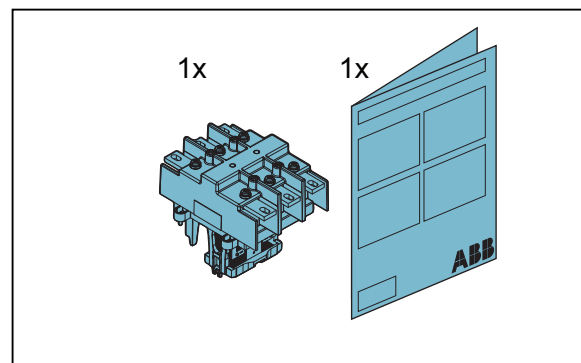
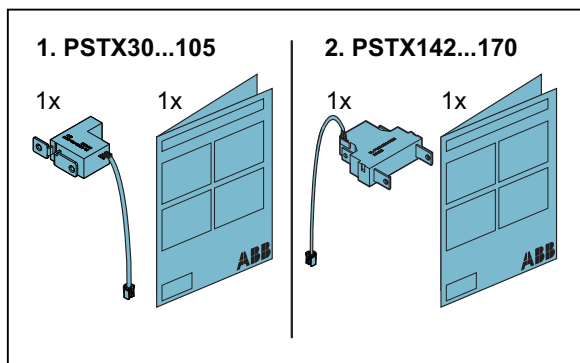
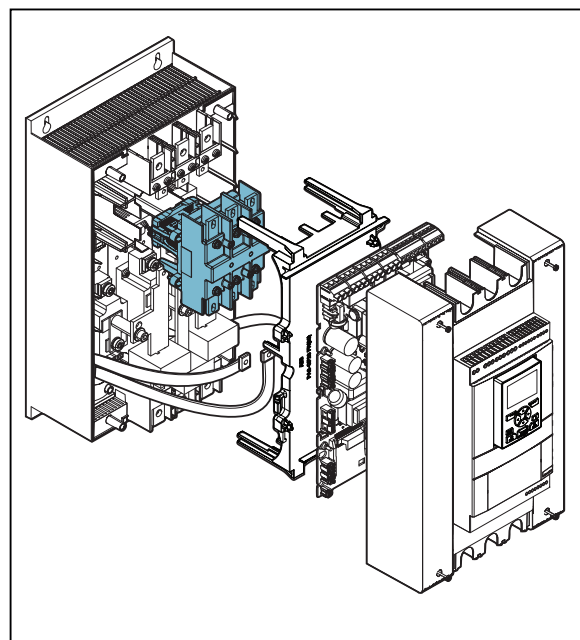
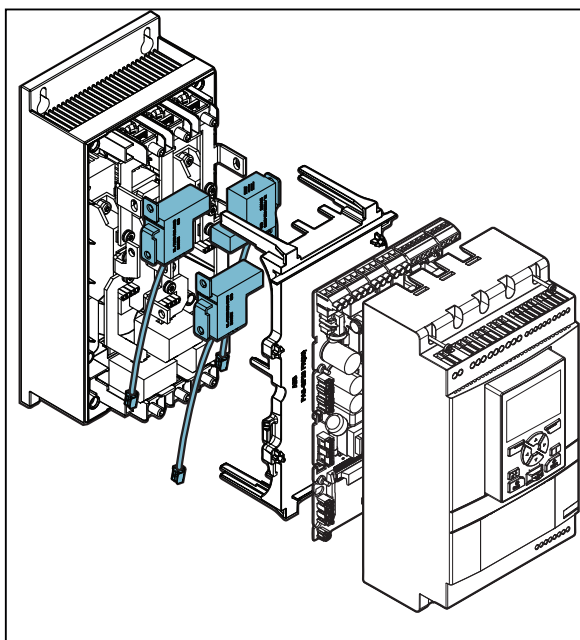
- Replace the bypass relay

### 2. PSTX142...170

- Replace the bypass relay

### 3. PSTX210...370

- Replace the bypass contactor



Power and productivity  
for a better world™



## Safety information



**Warning!** A qualified electrician must carry out installation, commissioning and service on the product by following installation standards and regulations. The product user hazardous voltage that can cause death or serious injury. Always disconnect power before working on equipment. Do not touch terminals when voltage is applied, output terminals can have live voltage even when the device is in off position. The product should only be used within the specified ratings. Check that you have the correct product in regards to mains voltage, supply voltage and rated product data.



**Warning!** Installation, idrifttagning och service av denna produkt skall endast utföras av behörig el-personal. Säkerhets- och installationsnormer skall följas. Produkten använder livsfarlig spänning, innan arbete utförs ska alltid spänningen frånskiljas. Rör inga anslutningar när produkten är spänningssatt, anslutningarna är spänningssatta även när produkten är i frånläge. Produkten skall endast användas inom dess specificerade data, kontrollera den gentemot huvudspänning, kontrollspänning och övriga märkdata.



**Warnung!** Installation, Inbetriebnahme und Service dieses Produktes darf nur durch qualifiziertes Fachpersonal unter Beachtung der nachfolgenden Hinweise und Erklärungen erfolgen. Die in dem Gerät vorhandenen Spannungen können bei Berührung zu tödlichen oder ernsthaften Verletzungen führen. Vor Arbeiten an dem Gerät ist grundsätzlich die Versorgung abzuschalten. Bei Anliegen der Versorgungsspannung dürfen keine Klemmen berührt werden, an den Ausgangsklemmen kann auch bei ausgeschaltetem Gerät eine gefährliche Spannung anliegen. Der Einsatz des Gerätes darf nur innerhalb der spezifizierten Bedingungen erfolgen. Überprüfen Sie vor Einsatz, dass die Gerätype bezüglich Versorgungsspannung, Schaltspannung und sonstiger Daten den Anforderungen entspricht.



**Avvertenza!** L'installazione, la messa in servizio e la manutenzione di questo prodotto devono essere effettuate solo da un elettricista qualificato, seguendo fedelmente le disposizioni in materia di installazione e sicurezza. Il prodotto utilizza tensioni pericolose che possono causare gravi danni o morte. Scollegare sempre l'alimentazione prima di accedere all'apparecchio. Non toccare mai i terminali quando l'apparecchio è sotto tensione: i terminali di uscita sono in tensione anche quando l'apparecchio è SPENTO. Prima dell'istallazione; verificare di aver scelto il prodotto corretto specialmente in termini di tensione di alimentazione, principale ed ausiliaria, ma più in generale per tutte le caratteristiche tecniche. Il prodotto va utilizzato solo nelle condizioni specificate.



**警告!** 产品的安装、调试及运行必须由具备资质的专业电工遵照相关标准及安全规范完成。产品使用能致命或引起严重伤害的危险电压。在产品上进行操作时务必断开电源。通电时不可接触接线端子，产品关断后输出端子仍有电压。产品仅能按照规定额定值使用。检查主回路电压，控制回路电压及其它产品参数符合产品规定。



**Avertissement!** Un électricien qualifié doit exécuter l'installation, la mise en service et l'entretien de ce produit en suivant les normes d'installation et les règles de sécurité. Le produit utilise une tension dangereuse qui peut causer la mort ou des blessures graves. Toujours débrancher l'alimentation avant de travailler sur l'équipement. Ne techiez pas les prises de raccordements lorsqu'une tension est appliquée, les prises de raccordements de sortie auront toujours une tension résiduelle, même si l'appareil est sur OFF. Le produit doit être seulement utilisé dans les calibres spécifiées. Vérifiez que vous avez le bon produit en ce qui concerne la tension du secteur, la tension d'alimentation nominale et les données produits.



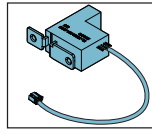
**Осторожно!** Установка, ввод в эксплуатацию и обслуживание данного оборудования должны производиться квалифицированным персоналом, специально допущенным к таким работам, в соответствии с действующим законодательством и требованиями предъявляемыми к обслуживанию электроустановок и обеспечению безопасности. В изделии используется опасное для человека напряжение, которое может привести к смерти или серьезным травмам. Всегда отключайте напряжение перед началом любых работ на оборудовании. Не затрагивайте до клемм и токоведущих частей когда приложено напряжение. На выходных клеммах может быть напряжение даже если прибор выключен. Прибор должен использоваться строго в соответствии с заявленными параметрами. Проверьте, что прибор подобран правильно и номинальные параметры находятся в соответствии с силовым напряжением и напряжением управления.



**تحذير!** يسمح فقط للفني أو المهندس الكهربائي المختص للقيام بأعمال التثبيت و التجهيز و الصيانة لهذا النوع من الاجهزة وذلك من خلال اتباع انظمة التوصيل والتثبيت الكهربائية العلامة وشروط السلامة المعتمدة. هذا النوع من الاجهزة يستخدم جهد خطر قد يؤدي لحدوث الاصابة أو الوفاة . دائما افصل مصدر التيار قبل بدء العمل على الجهاز . لاتلمس أطراف التوصيل عندما يكون هناك جهد مطبق لأن مخارج أطراف التوصيل تحتفظ بلاجهد حتى بعد فصل مصدر الجهد. هذا الجهاز يجب استخدامه مع ما يناسبه من قيم محددة . تأد دائما من حصولك على الجهاز المناسب لمصدر الفولتية والتردد والقيم المحددة للتيار .

# 1. PSTX30...105

## - Replace the bypass relay



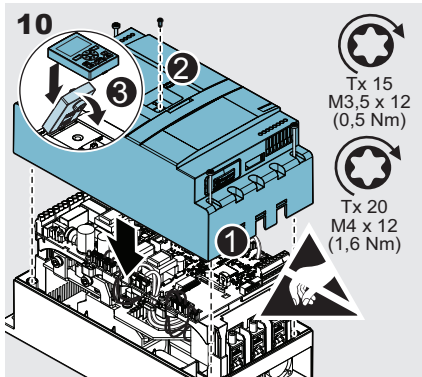
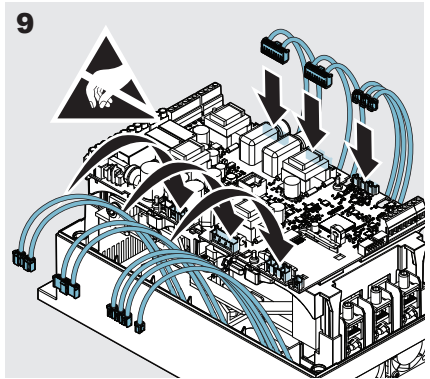
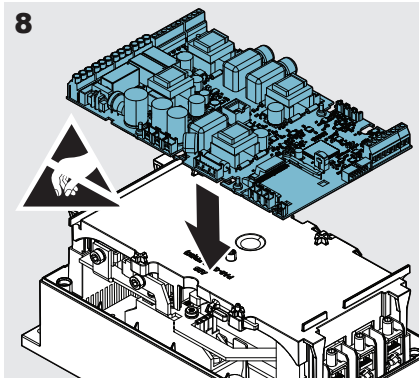
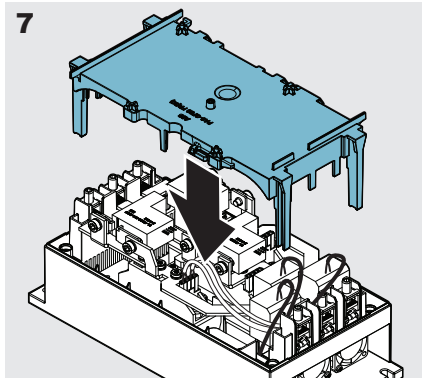
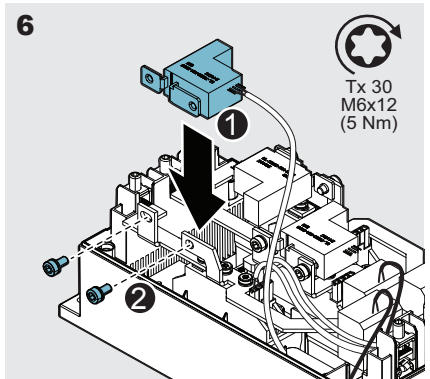
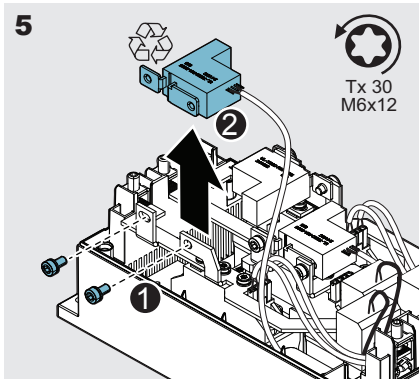
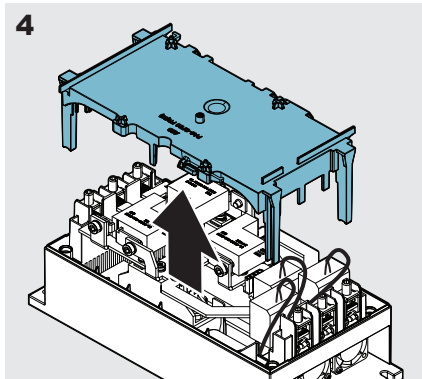
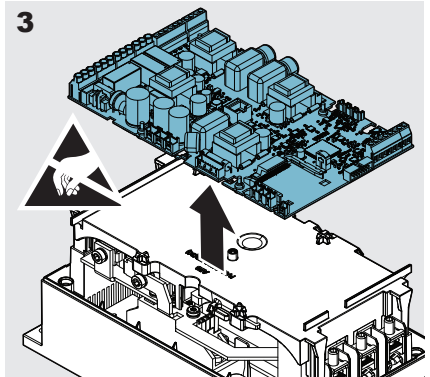
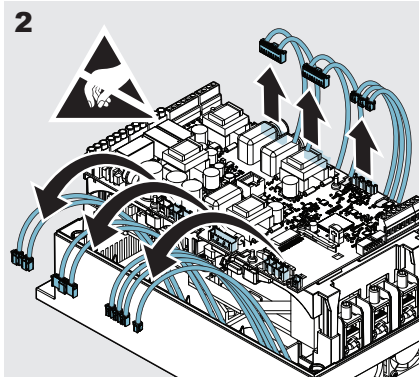
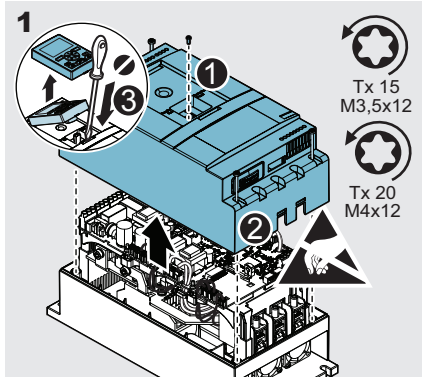
### WARNING

When performing maintenance on the Softstarter, an antistatic strap must be used. The antistatic strap should be worn on the wrist, and be connected to an electrical ground, to prevent electrostatic discharge (ESD) damage to the Softstarter.



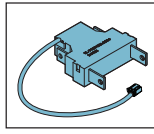
### WARNING

Always make sure that the power supply is switched off before doing maintenance on the Softstarter.



## 2. PSTX142...170

### - Replace the bypass relay



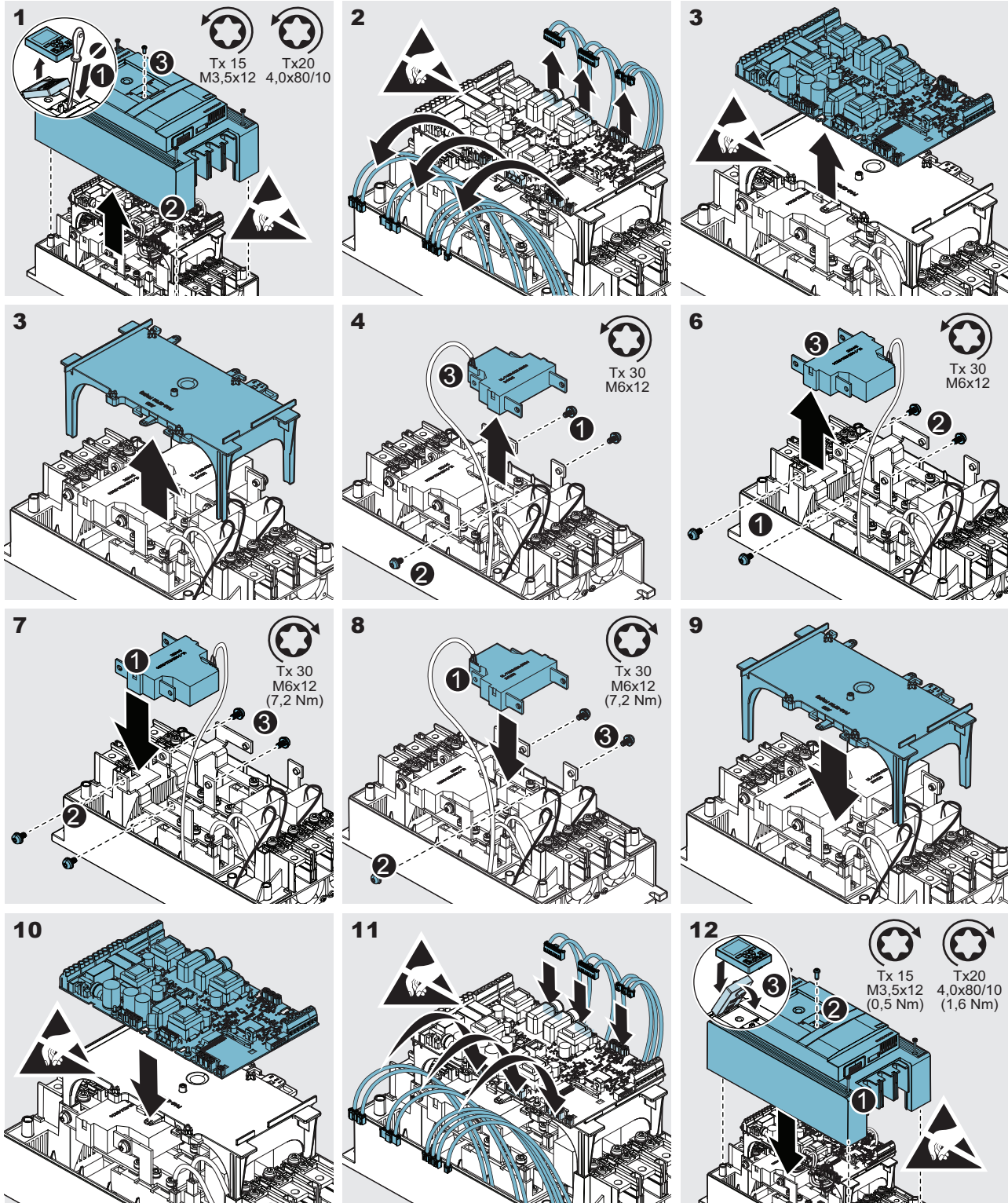
#### WARNING

Always make sure that the power supply is switched off before doing maintenance on the Softstarter.



#### WARNING

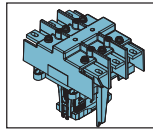
When performing maintenance on the Softstarter, an antistatic strap must be used. The antistatic strap should be worn on the wrist, and be connected to an electrical ground, to prevent electrostatic discharge (ESD) damage to the Softstarter.





### 3. PSTX210...370

#### - Replace the bypass contactor



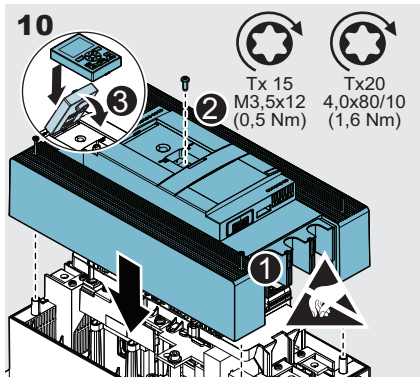
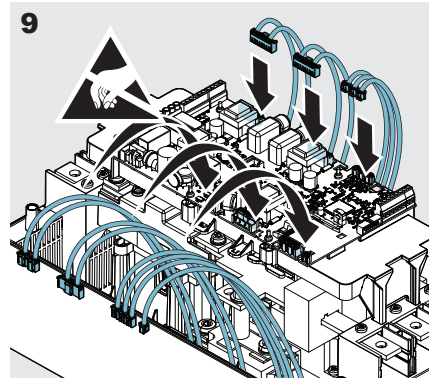
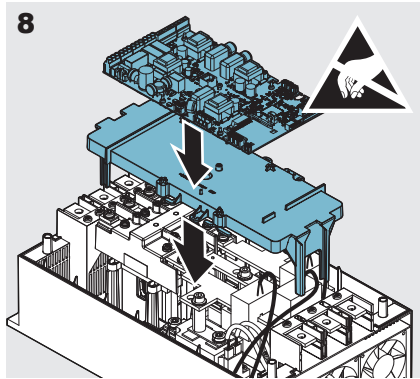
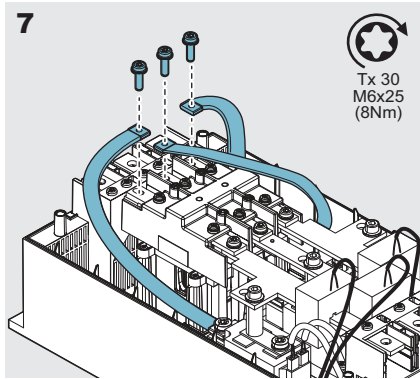
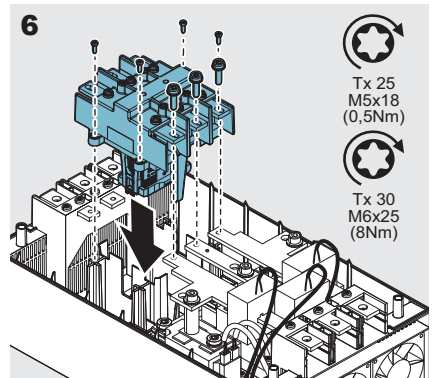
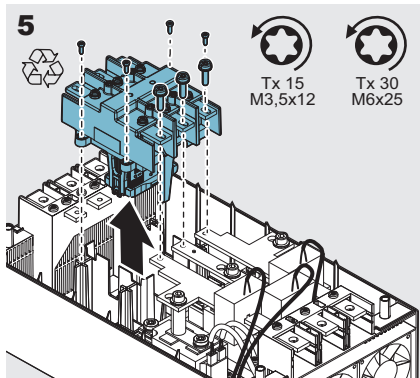
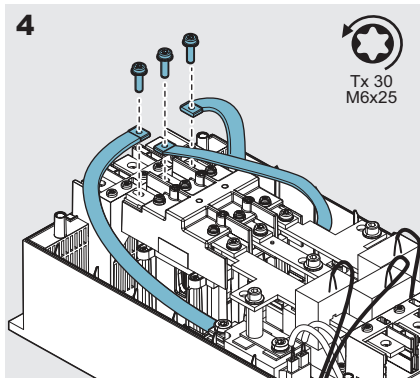
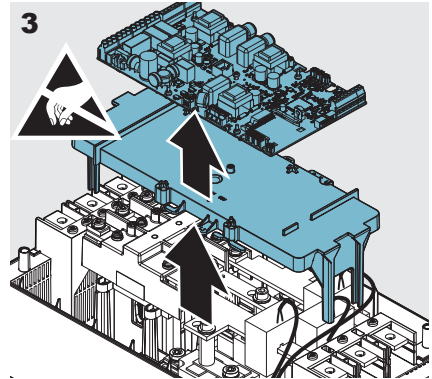
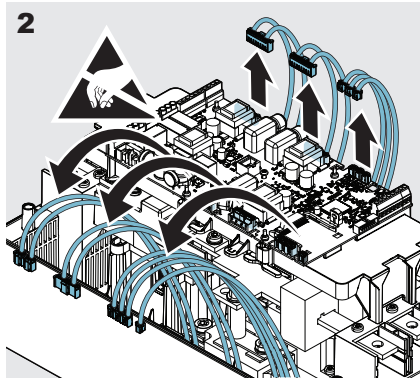
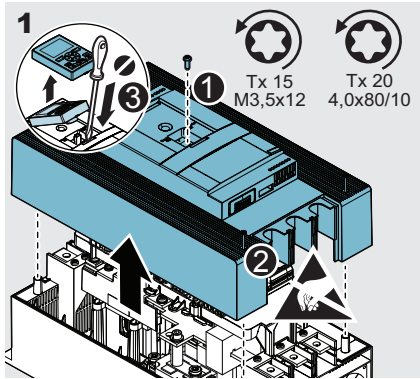
#### WARNING

Always make sure that the power supply is switched off before doing maintenance on the Softstarter.



#### WARNING

When performing maintenance on the Softstarter, an antistatic strap must be used. The antistatic strap should be worn on the wrist, and be connected to an electrical ground, to prevent electrostatic discharge (ESD) damage to the Softstarter.



# Contact us

**ABB AB**  
**Control Products**  
**Low voltage Products**

SE-721 61 Västerås, Sweden  
Telephone: +46 (0) 21 32 50 00

[www.abb.com/lowvoltage](http://www.abb.com/lowvoltage)

Softstarter Type PSTX30...370, Spare part instruction, 1SFC132109M0201, 2015-12-07, ABB AB, Control Products

# Softstarter type PSTX30...370

## Spare part instruction - Replace the current transformer

1SFC132106M0201 January 2016

Rev A

EN | Spare part instruction

| Softstarter type PSTX30...370

| Replace the current transformer

### General

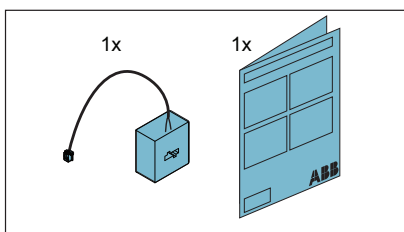
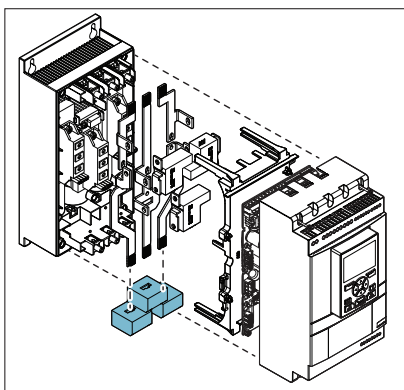
For complete information, see 1SFC132081M0201 - Softstarters Type PSTX30...PSTX1250, Installation and Commissioning Manual available on: <http://www.abb.com/lowvoltage>



Service and repair should be performed by authorized personnel only. Note that unauthorized repair affects safety and warranty.

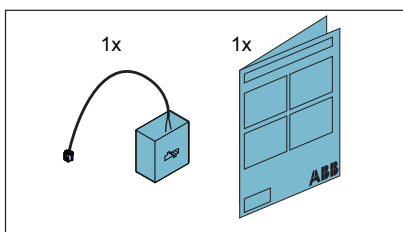
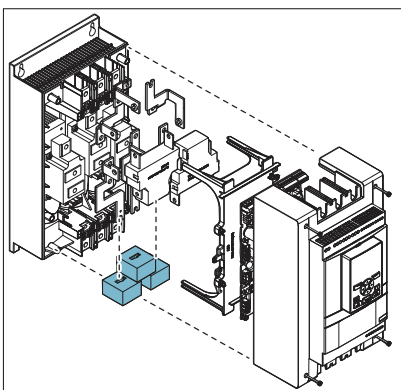
### 1. PSTX30...105

- Replace the current transformer



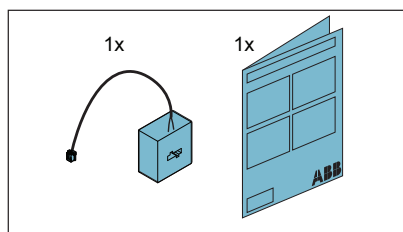
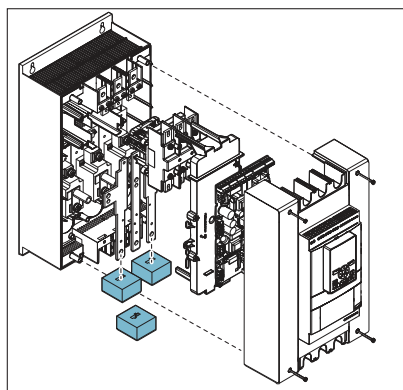
### 2. PSTX142...170

- Replace the current transformer



### 3. PSTX210...370

- Replace the current transformer



Power and productivity  
for a better world™



## Safety information



**Warning!** A qualified electrician must carry out installation, commissioning and service on the product by following installation standards and regulations. The product user hazardous voltage that can cause death or serious injury. Always disconnect power before working on equipment. Do not touch terminals when voltage is applied, output terminals can have live voltage even when the device is in off position. The product should only be used within the specified ratings. Check that you have the correct product in regards to mains voltage, supply voltage and rated product data.



**Warning!** Installation, idrifttagning och service av denna produkt skall endast utföras av behörig el-personal. Säkerhets- och installationsnormer skall följas. Produkten använder livsfarlig spänning, innan arbete utförs ska alltid spänningen frånskiljas. Rör inga anslutningar när produkten är spänningssatt, anslutningarna är spänningssatta även när produkten är i frånläge. Produkten skall endast användas inom dess specificerade data, kontrollera den gentemot huvudspänning, kontrollspänning och övriga märkdata.



**Warnung!** Installation, Inbetriebnahme und Service dieses Produktes darf nur durch qualifiziertes Fachpersonal unter Beachtung der nachfolgenden Hinweise und Erklärungen erfolgen. Die in dem Gerät vorhandenen Spannungen können bei Berührung zu tödlichen oder ernsthaften Verletzungen führen. Vor Arbeiten an dem Gerät ist grundsätzlich die Versorgung abzuschalten. Bei Anliegen der Versorgungsspannung dürfen keine Klemmen berührt werden, an den Ausgangsklemmen kann auch bei ausgeschaltetem Gerät eine gefährliche Spannung anliegen. Der Einsatz des Gerätes darf nur innerhalb der spezifizierten Bedingungen erfolgen. Überprüfen Sie vor Einsatz, dass die Gerätype bezüglich Versorgungsspannung, Schaltspannung und sonstiger Daten den Anforderungen entspricht.



**Avvertenza!** L'installazione, la messa in servizio e la manutenzione di questo prodotto devono essere effettuate solo da un elettricista qualificato, seguendo fedelmente le disposizioni in materia di installazione e sicurezza. Il prodotto utilizza tensioni pericolose che possono causare gravi danni o morte. Scollegare sempre l'alimentazione prima di accedere all'apparecchio. Non toccare mai i terminali quando l'apparecchio è sotto tensione: i terminali di uscita sono in tensione anche quando l'apparecchio è SPENTO. Prima dell'istallazione; verificare di aver scelto il prodotto corretto specialmente in termini di tensione di alimentazione, principale ed ausiliaria, ma più in generale per tutte le caratteristiche tecniche. Il prodotto va utilizzato solo nelle condizioni specificate.



**警告!** 产品的安装、调试及运行必须由具备资质的专业电工遵照相关标准及安全规范完成。产品使用能致命或引起严重伤害的危险电压。在产品上进行操作时务必断开电源。通电时不可接触接线端子，产品关断后输出端子仍有电压。产品仅能按照规定额定值使用。检查主回路电压，控制回路电压及其它产品参数符合产品规定。



**Avertissement!** Un électricien qualifié doit exécuter l'installation, la mise en service et l'entretien de ce produit en suivant les normes d'installation et les règles de sécurité. Le produit utilise une tension dangereuse qui peut causer la mort ou des blessures graves. Toujours débrancher l'alimentation avant de travailler sur l'équipement. Ne techiez pas les prises de raccordements lorsqu'une tension est appliquée, les prises de raccordements de sortie auront toujours une tension résiduelle, même si l'appareil est sur OFF. Le produit doit être seulement utilisé dans les calibres spécifiées. Vérifiez que vous avez le bon produit en ce qui concerne la tension du secteur, la tension d'alimentation nominale et les données produits.



**Осторожно!** Установка, ввод в эксплуатацию и обслуживание данного оборудования должны производиться квалифицированным персоналом, специально допущенным к таким работам, в соответствии с действующим законодательством и требованиями предъявляемыми к обслуживанию электроустановок и обеспечению безопасности. В изделии используется опасное для человека напряжение, которое может привести к смерти или серьезным травмам. Всегда отключайте напряжение перед началом любых работ на оборудовании. Не затрагивайте до клемм и токоведущих частей когда приложено напряжение. На выходных клеммах может быть напряжение даже если прибор выключен. Прибор должен использоваться строго в соответствии с заявленными параметрами. Проверьте, что прибор подобран правильно и номинальные параметры находятся в соответствии с силовым напряжением и напряжением управления.



**تحذير!** يسمح فقط للفني أو المهندس الكهربائي المختص للقيام بأعمال التثبيت و التجهيز و الصيانة لهذا النوع من الاجهزة وذلك من خلال اتباع انظمة التوصيل والتثبيت الكهربائية العلامة وشروط السلامة المعتمدة. هذا النوع من الاجهزة يستخدم جهد خطر قد يؤدي لحدوث الاصابة أو الوفاة . دائما افصل مصدر التيار قبل بدء العمل على الجهاز . لاتلمس أطراف التوصيل عندما يكون هناك جهد مطبق لأن مخارج أطراف التوصيل تحتفظ بلاجهد حتى بعد فصل مصدر الجهد. هذا الجهاز يجب استخدامه مع ما يناسبه من قيم محددة . تأد دائما من حصولك على الجهاز المناسب لمصدر الفولتية والتردد والقيم المحددة للتيار .

# 1. PSTX30...105

## - Replace the current transformer



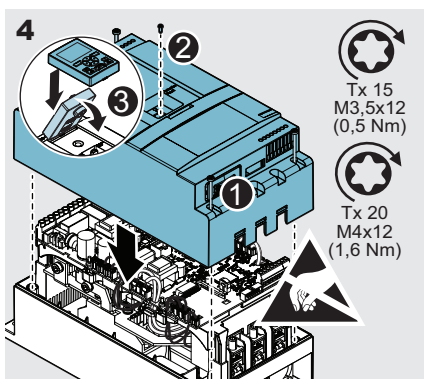
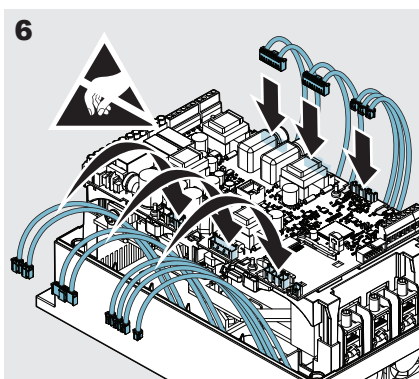
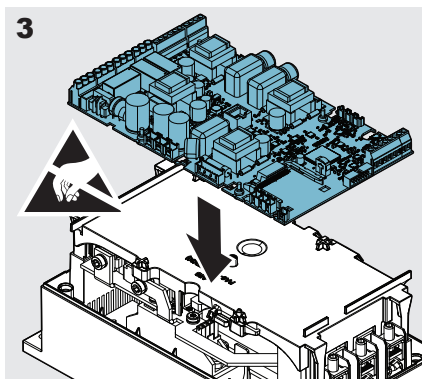
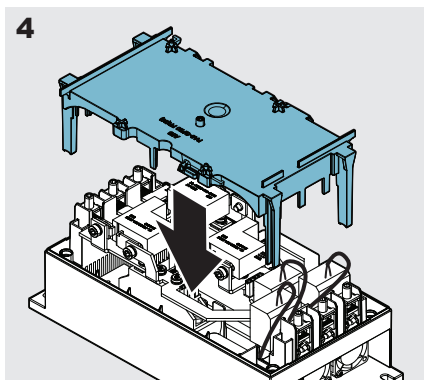
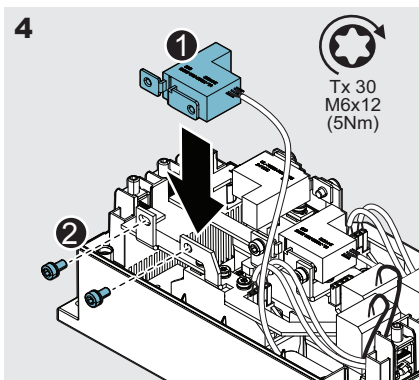
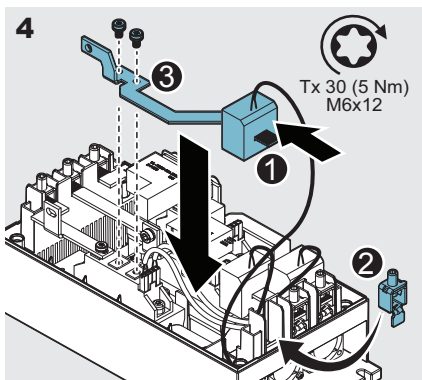
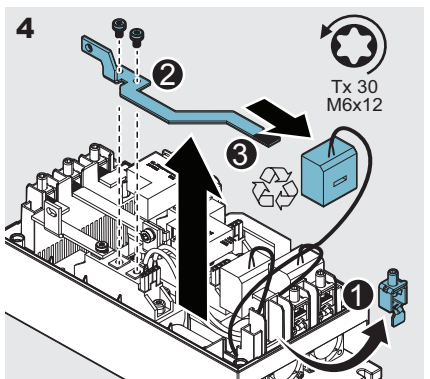
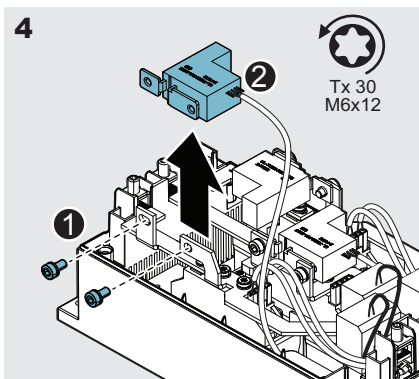
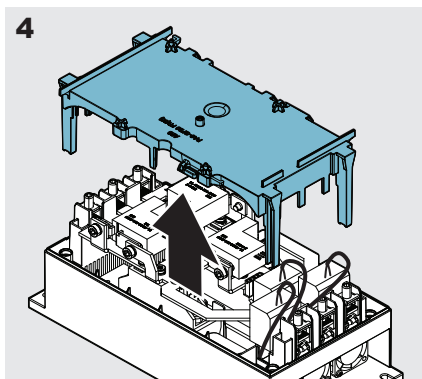
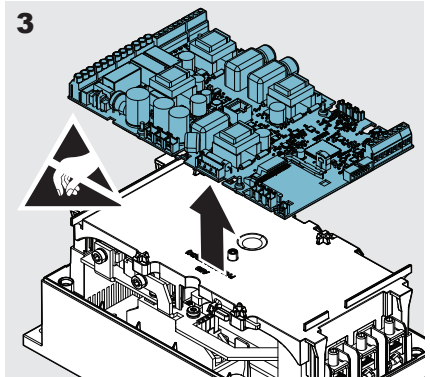
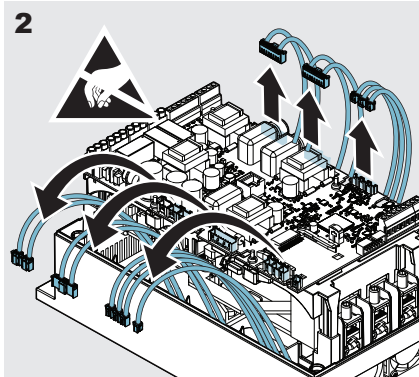
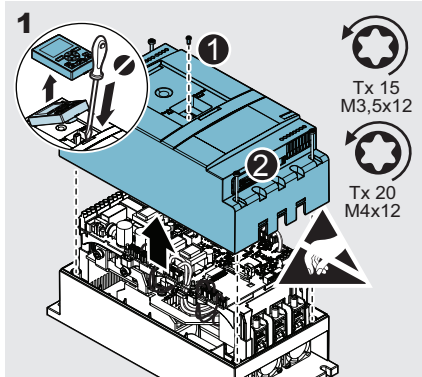
### WARNING

When performing maintenance on the Softstarter, an antistatic strap must be used. The antistatic strap should be worn on the wrist, and be connected to an electrical ground, to prevent electrostatic discharge (ESD) damage to the Softstarter.



### WARNING

Always make sure that the power supply is switched off before doing maintenance on the Softstarter.



## 2. PSTX142...170

### - Replace the current transformer



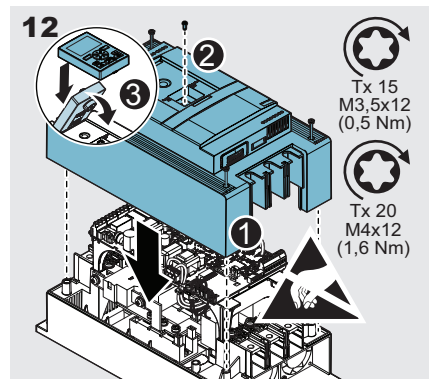
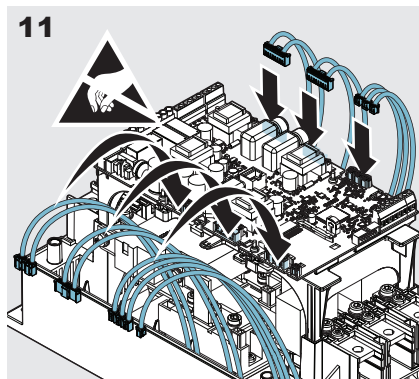
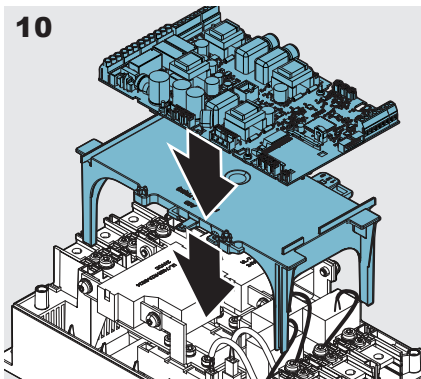
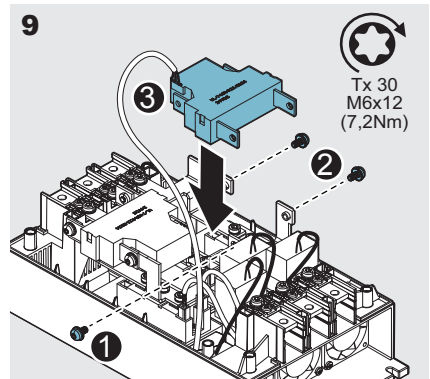
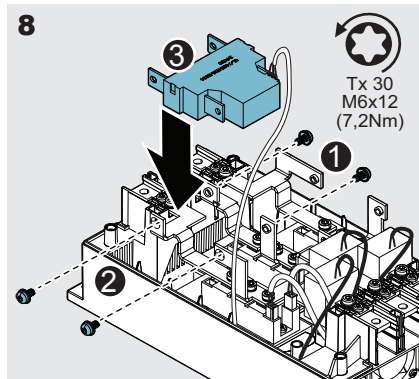
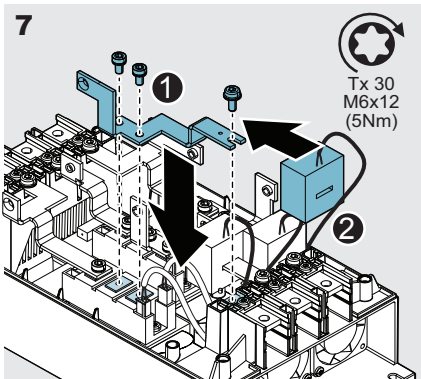
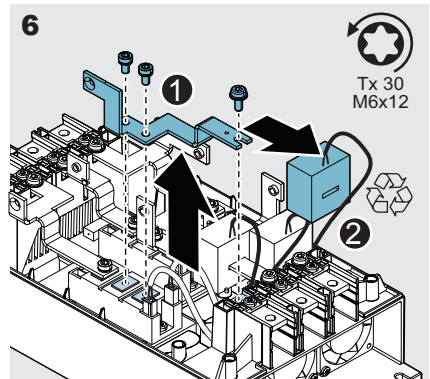
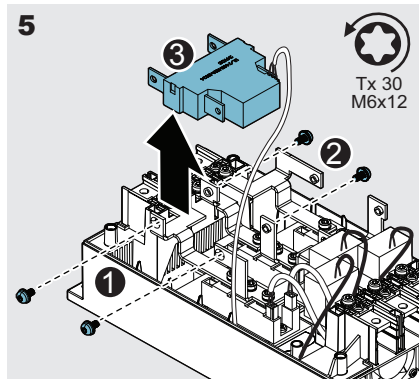
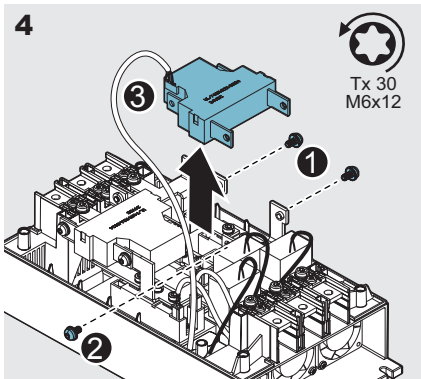
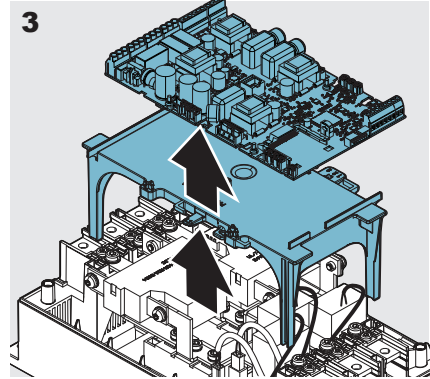
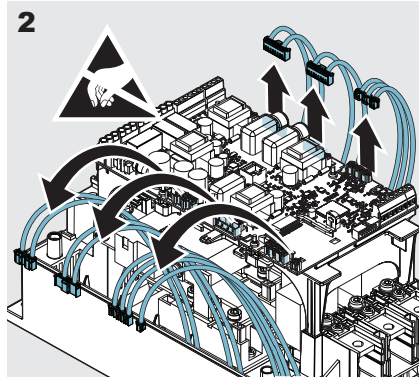
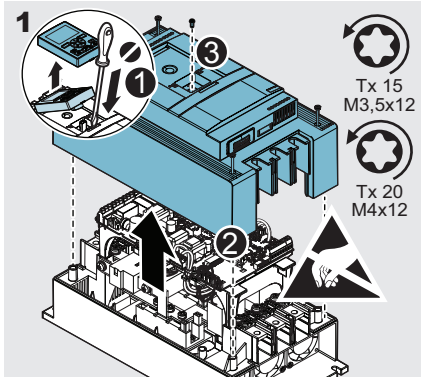
#### WARNING

Always make sure that the power supply is switched off before doing maintenance on the Softstarter.



#### WARNING

When performing maintenance on the Softstarter, an antistatic strap must be used. The antistatic strap should be worn on the wrist, and be connected to an electrical ground, to prevent electrostatic discharge (ESD) damage to the Softstarter.



### 3. PSTX210...370 - Replace the current transformer



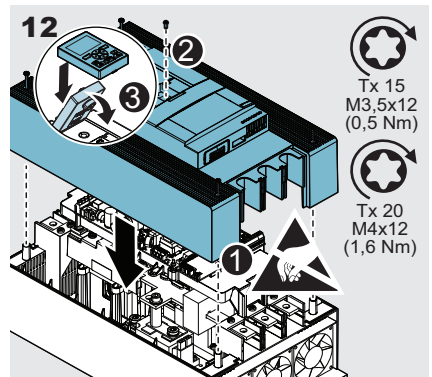
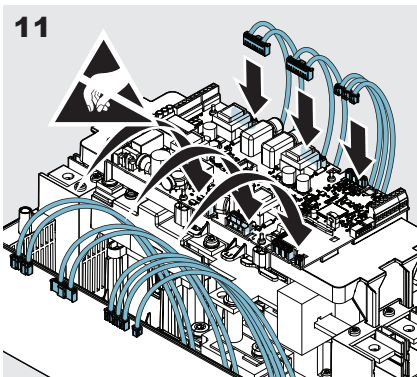
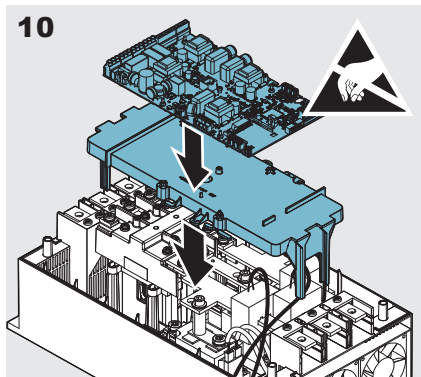
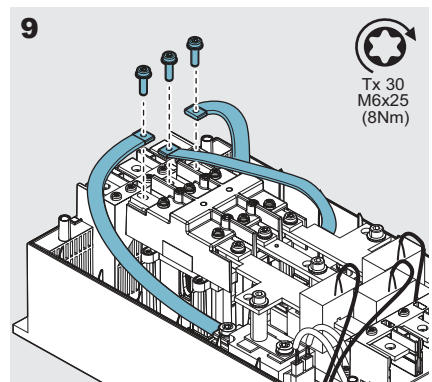
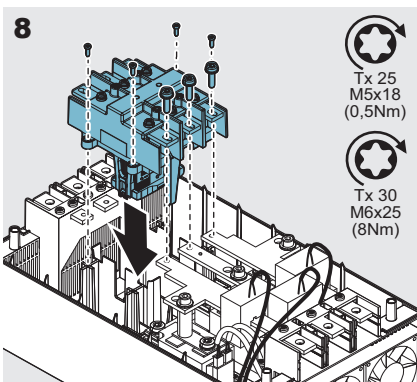
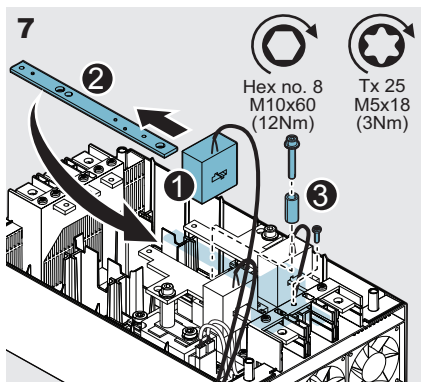
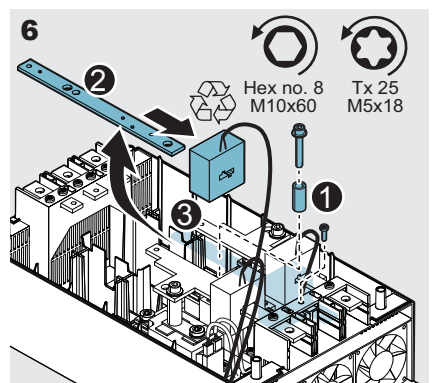
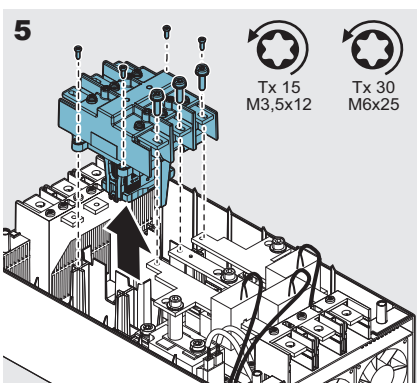
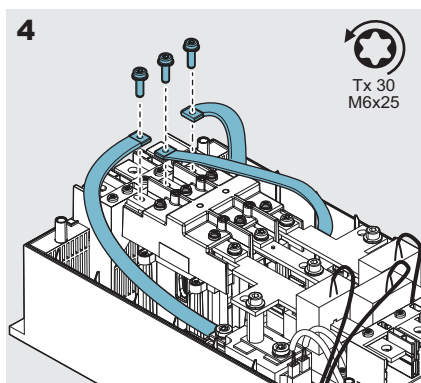
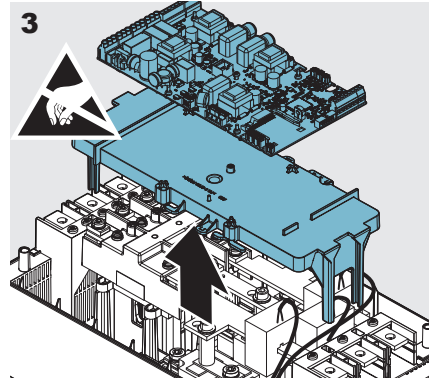
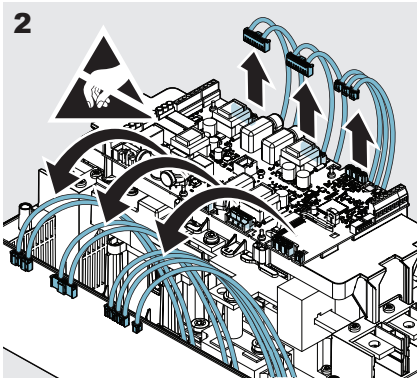
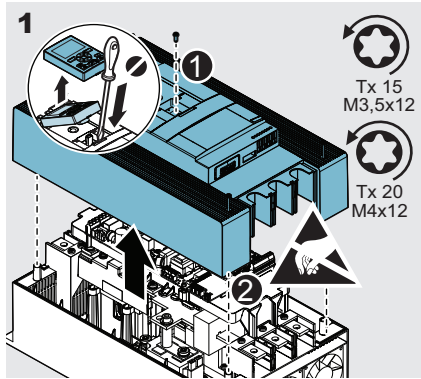
#### WARNING

Always make sure that the power supply is switched off before doing maintenance on the Softstarter.



#### WARNING

When performing maintenance on the Softstarter, an antistatic strap must be used. The antistatic strap should be worn on the wrist, and be connected to an electrical ground, to prevent electrostatic discharge (ESD) damage to the Softstarter.



# Contact us

**ABB AB**

**Control Products**

**Low voltage Products**

SE-721 61 Västerås, Sweden

Telephone: +46 (0) 21 32 50 00

[www.abb.com/lowvoltage](http://www.abb.com/lowvoltage)

Sofstarter Type PSTX30...370, Spare part instruction, 1SFC132106M0201, 2016-01-05, ABB AB, Control Products

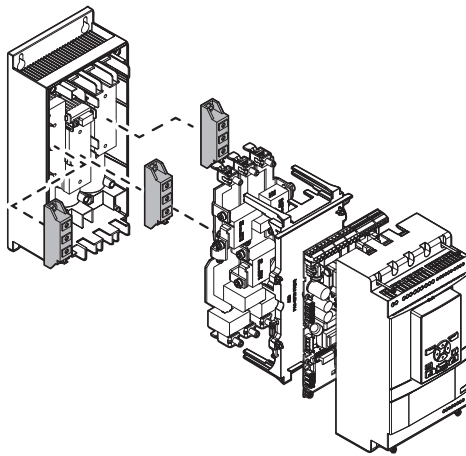


Service instruction

# Softstarter spare part

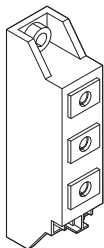
## PSTX30...PSTX370

### Replace the SCR's



### SCR's

1x



M5x10 x 3



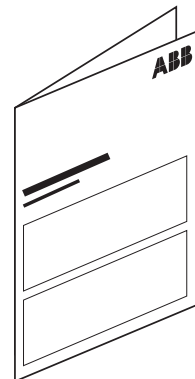
M6x12 x 7



M8x16 x 3



1x



## Safety information



**Important information:** A qualified electrician must carry out installation, commissioning and service on the product by following installation standards and regulations. The product user hazardous voltage that can cause death or serious injury. Always disconnect power before working on equipment. Do not touch terminals when voltage is applied, output terminals can have live voltage even when the device is in off position. The product should only be used within the specified ratings. Check that you have the correct product in regards to mains voltage, supply voltage and rated product data.



**Viktig information:** Installation, idrifttagning och service av denna produkt skall endast utföras av behörig el-personal. Säkerhets- och installationsnormer skall följas. Produkten använder livsfarlig spänning, innan arbete utförs ska alltid spänningen fränskiljas. Rör inga anslutningar när produkten är spänningssatt, anslutningarna är spänningssatta även när produkten är i fränläge. Produkten skall endast användas inom dess specificerade data, kontrollera den gentemot huvudspänning, kontrollspänning och övriga märkdata.



**Wichtige Information:** Installation, Inbetriebnahme und Service dieses Produktes darf nur durch qualifiziertes Fachpersonal unter Beachtung der nachfolgenden Hinweise und Erklärungen erfolgen. Die in dem Gerät vorhandenen Spannungen können bei Berührung zu tödlichen oder ernsthaften Verletzungen führen. Vor Arbeiten an dem Gerät ist grundsätzlich die Versorgung abzuschalten. Bei Anliegen der Versorgungsspannung dürfen keine Klemmen berührt werden, an den Ausgangsklemmen kann auch bei ausgeschaltetem Gerät eine gefährliche Spannung anliegen. Der Einsatz des Gerätes darf nur innerhalb der spezifizierten Bedingungen erfolgen. Überprüfen Sie vor Einsatz, dass die Geräetype bezüglich Versorgungsspannung, Schaltspannung und sonstiger Daten den Anforderungen entspricht.



**Informazioni importanti:** L'installazione, la messa in servizio e la manutenzione di questo prodotto devono essere effettuate solo da un elettricista qualificato, seguendo fedelmente le disposizioni in materia di installazione e sicurezza. Il prodotto utilizza tensioni pericolose che possono causare gravi danni o morte. Scollegare sempre l'alimentazione prima di accedere all'apparecchio. Non toccare mai i terminali quando l'apparecchio è sotto tensione: i terminali di uscita sono in tensione anche quando l'apparecchio è SPENTO. Prima dell'installazione; verificare di aver scelto il prodotto corretto specialmente in termini di tensione di alimentazione, principale ed ausiliaria, ma più in generale per tutte le caratteristiche tecniche. Il prodotto va utilizzato solo nelle condizioni specificate.



**重要信息:** 产品的安装、调试及运行必须由具备资质的专业电工遵照相关标准及安全规范完成。产品使用能致命或引起严重伤害的危险电压。在产品上进行操作时务必断开电源。通电时不可接触接线端子，产品关断后输出端子仍有电压。产品仅能按照规定额定值使用。检查主回路电压，控制回路电压及其它产品参数符合产品规定。



**Informations importantes:** Un électricien qualifié doit exécuter l'installation, la mise en service et l'entretien de ce produit en suivant les normes d'installation et les règles de sécurité. Le produit utilise une tension dangereuse qui peut causer la mort ou des blessures graves. Toujours débrancher l'alimentation avant de travailler sur l'équipement. Ne touchez pas les prises de raccordements lorsqu'une tension est appliquée, les prises de raccordements de sortie auront toujours une tension résiduelle, même si l'appareil est sur OFF. Le produit doit être seulement utilisé dans les calibres spécifiées. Vérifiez que vous avez le bon produit en ce qui concerne la tension du secteur, la tension d'alimentation nominale et les données produits.



**Важная информация:** Ус тановка, ввод в эксплуатацию и обслуживание данного оборудования должны производиться квалифицированным персоналом, специально допущенным к таким работам, в соответствии с действующим законодательством и требованиями предъявляемыми к обслуживанию электроустановок и обеспечению безопасности. В издании используется опасное для человека напряжение, которое может привести к смерти или серьезным травмам. Всегда отключайте напряжение перед началом любых работ на оборудовании. Не дотрагивайтесь до клемм и токоведущих частей когда приложено напряжение. На выходных клеммах может быть напряжение даже если прибор выключен. Прибор должен использоваться строго в соответствии с заявленными параметрами. Проверьте, что прибор подобран правильно и номинальные параметры находятся в соответствии с силовым напряжением и напряжением управления.



**تحذير:** يسمح فقط للفني أو المهندس الكهربائي المختص للقيام بأعمال التثبيت و التجهيز و الصيانة لهذا النوع من الاجهزة وذلك من خلال اتباع أنظمة التوصيل والترابيت الكهربائية العلامية وشروط السلامة المعتمدة. هذا النوع من الأجهزة يستخدم جهد خطر قد يؤدي لحدوث الإصابة أو الوفاة . دائما افصل مصدر التيار قبل بدء العمل على الجهاز . لاتلمس أطراف التوصيل عندما يكون هنالك جهد مطبق لأن مخارج أطراف التوصيل تحتفظ بلاجهد حتى بعد فصل مصدر الجهد. هذا الجهاز يجب استخدامه مع ما يناسبه من قيم محددة . تأد دائما من حصولك على الجهاز المناسب لمصدر الفولتية والتردد والقيم المحددة للتيار .



Service and repair should be performed by authorized personnel only. Note that unauthorized repair affects safety and warranty.

### General

For complete information, see 1SFC132081M0201 - Softstarters Type PSTX30...PSTX370, Installation and Commissioning

Manuals available on:  
[new.abb.com/low-voltage/products/softstarters](http://new.abb.com/low-voltage/products/softstarters)

# Service instruction - Replace the SCR's

PSTX30...PSTX105



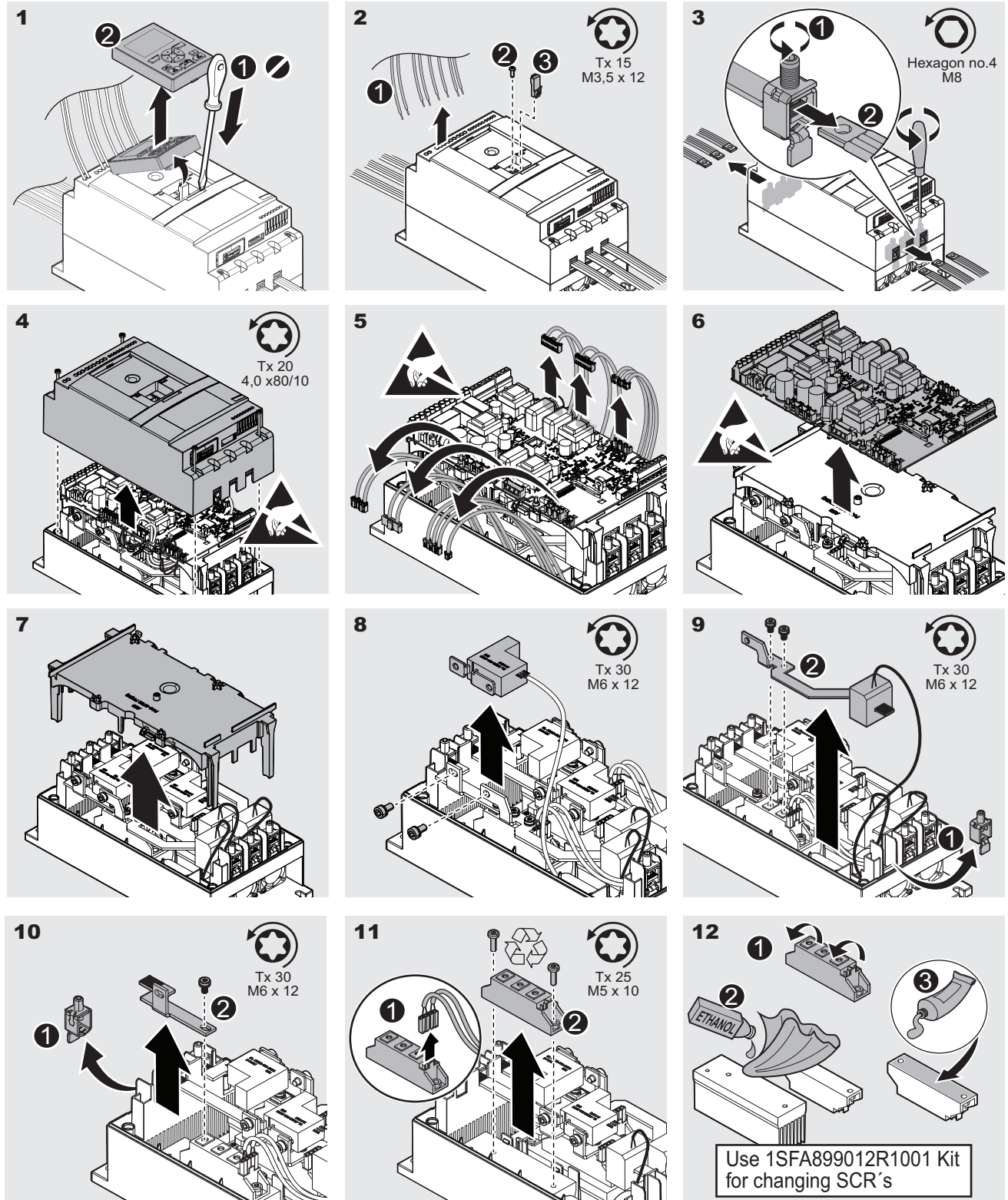
## CAUTION

Always make sure that the power supply is switched off before carrying out installation or maintenance on the Softstarter.



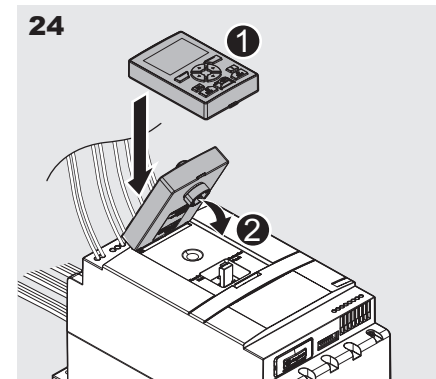
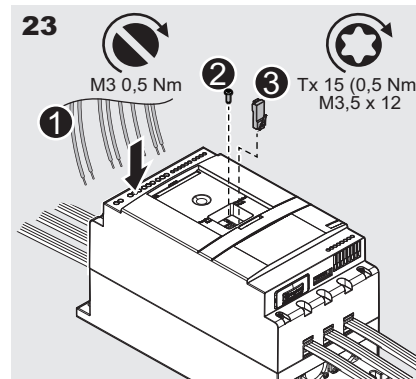
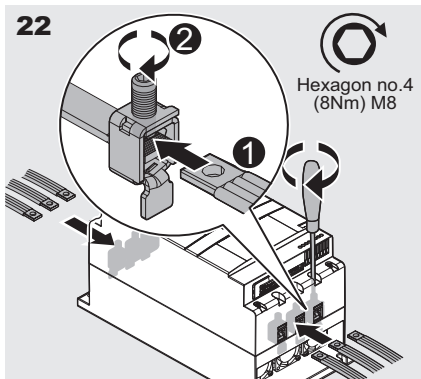
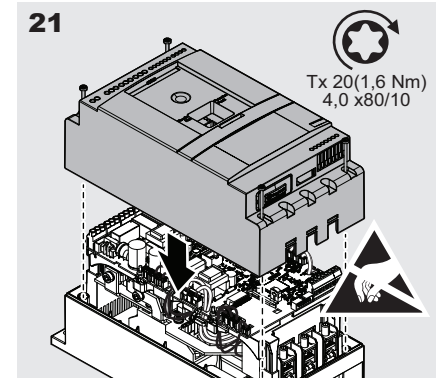
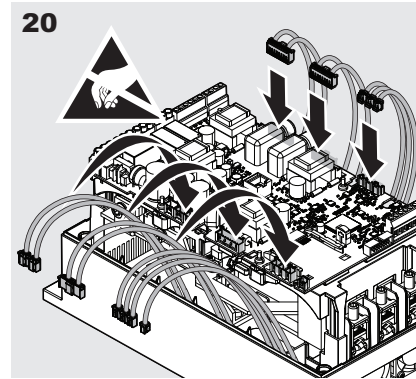
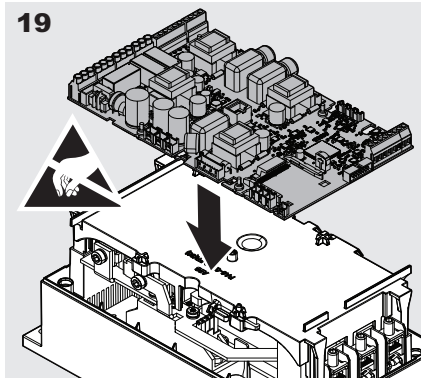
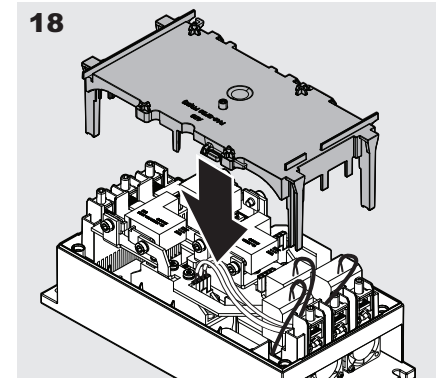
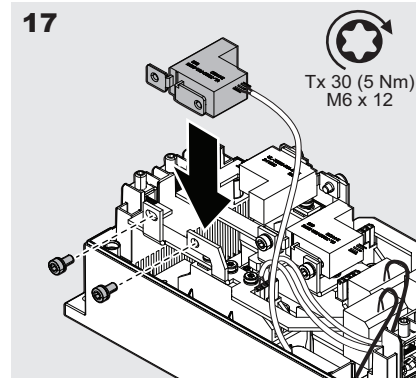
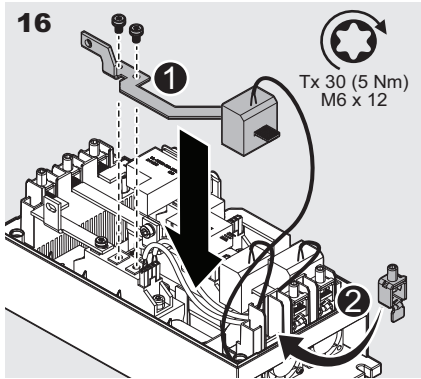
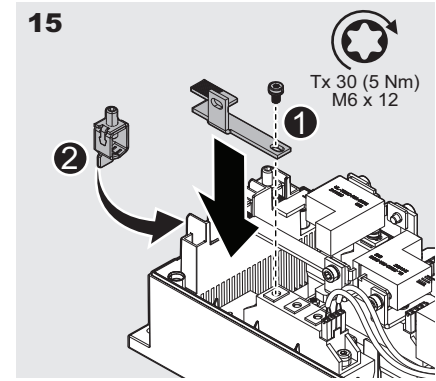
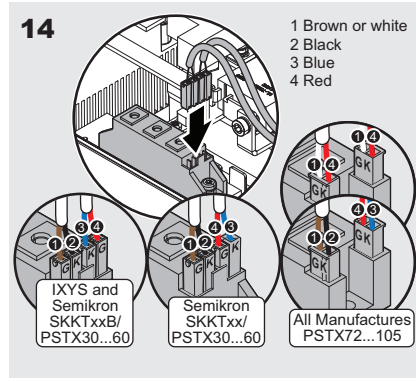
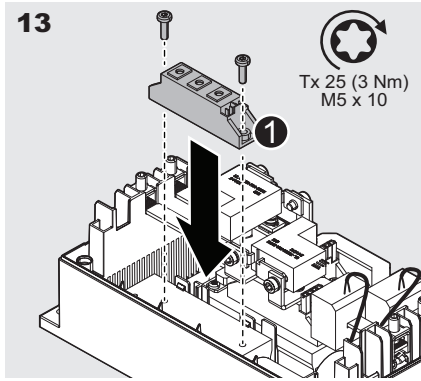
## WARNING

When performing maintenance on the Softstarter, an antistatic strap must be used. The antistatic strap should be worn on the wrist, and be connected to an electrical ground, to prevent electrostatic discharge (ESD) damage to the Softstarter.



# Service instruction - Replace the SCR's

PSTX30...PSTX105



# Service instruction - Replace the SCR's

PSTX142...PSTX170



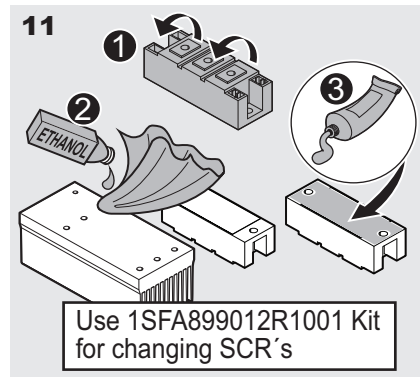
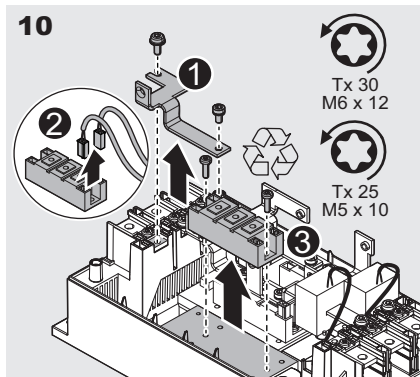
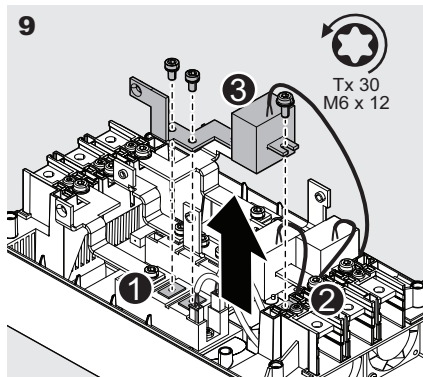
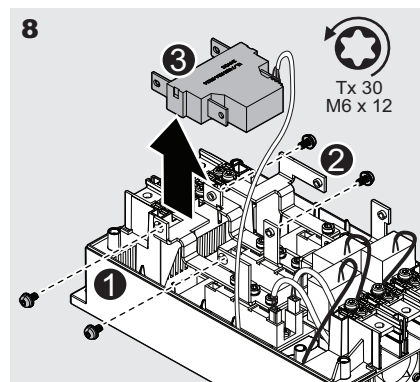
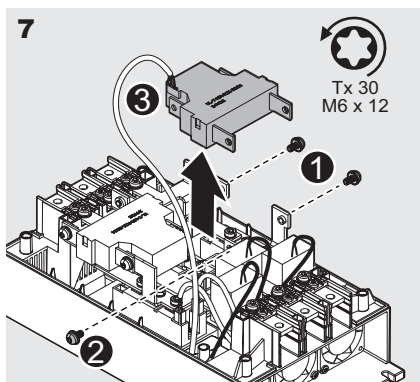
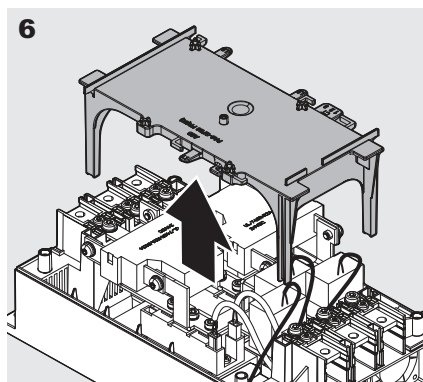
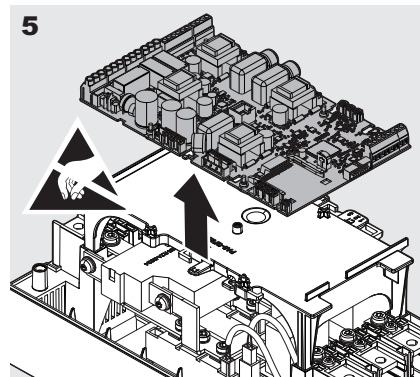
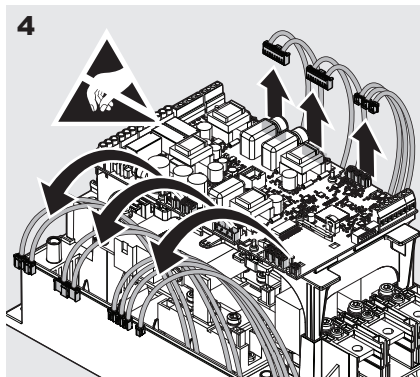
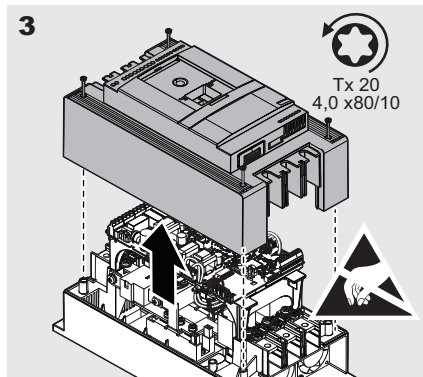
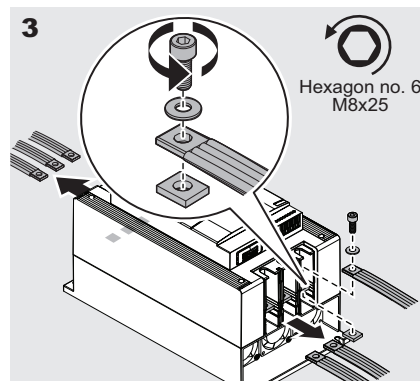
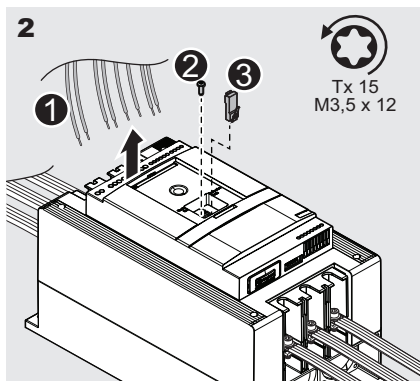
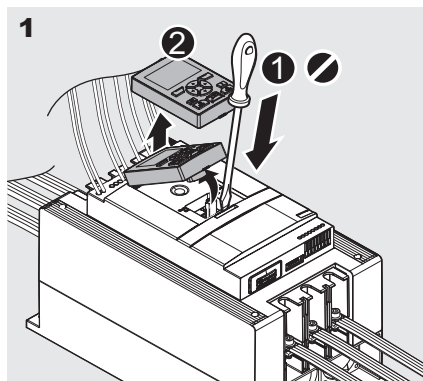
## CAUTION

Always make sure that the power supply is switched off before carrying out installation or maintenance on the Softstarter.



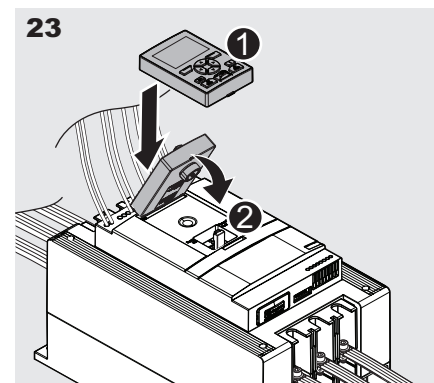
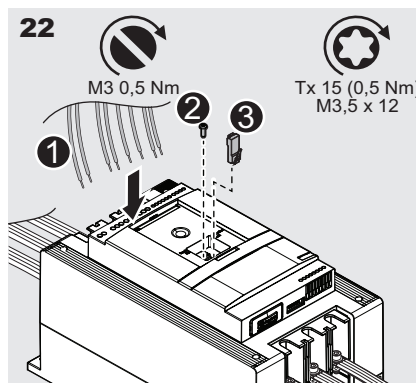
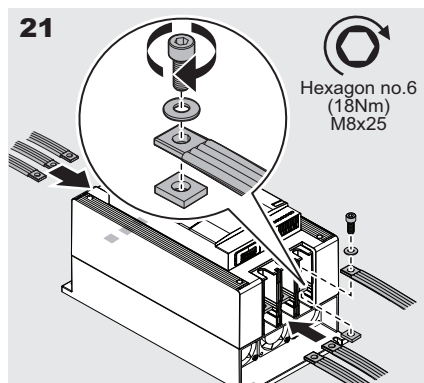
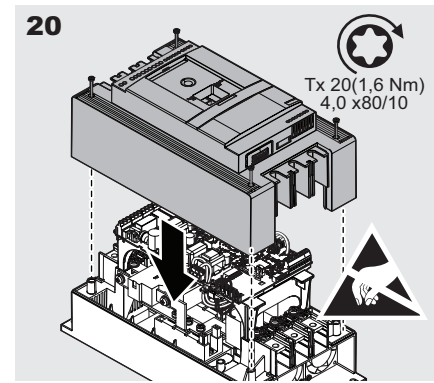
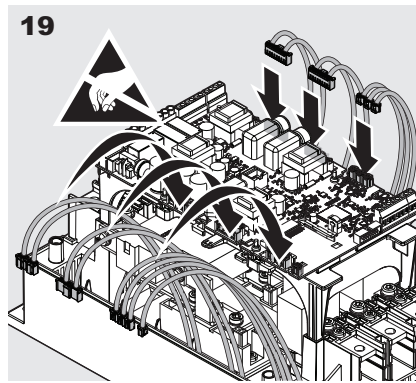
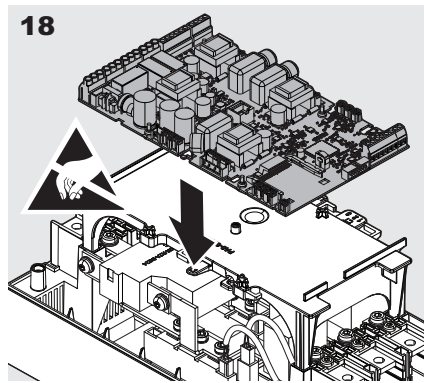
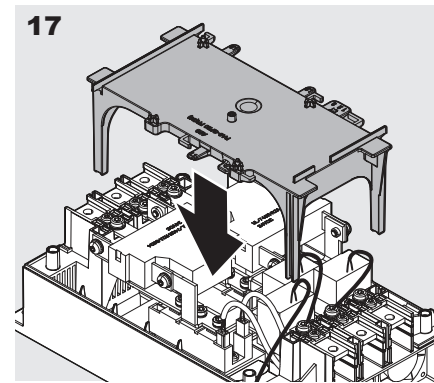
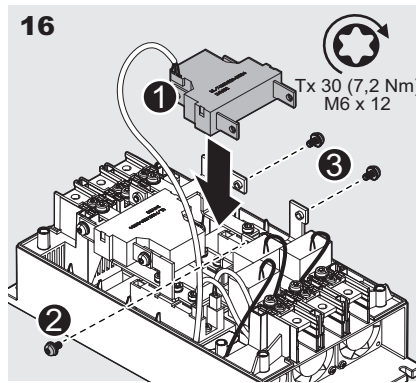
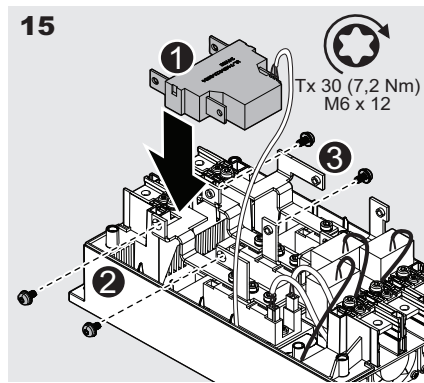
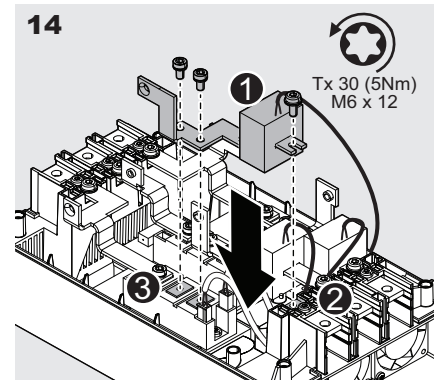
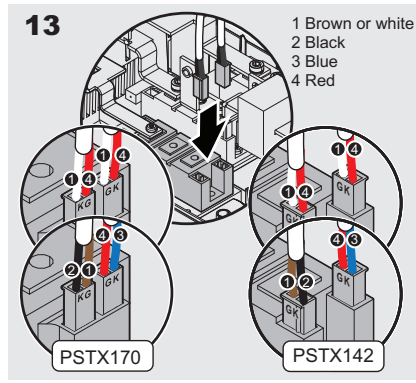
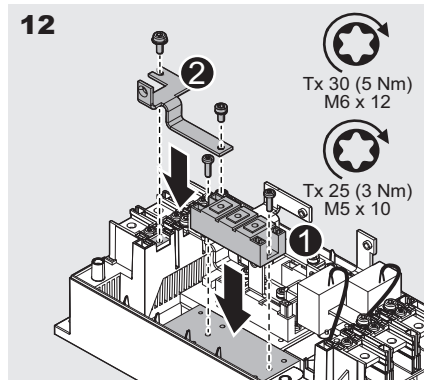
## WARNING

When performing maintenance on the Softstarter, an antistatic strap must be used. The antistatic strap should be worn on the wrist, and be connected to an electrical ground, to prevent electrostatic discharge (ESD) damage to the Softstarter.



# Service instruction - Replace the SCR's

PSTX142...PSTX170



# Service instruction - Replace the SCR's

PSTX210...PSTX370



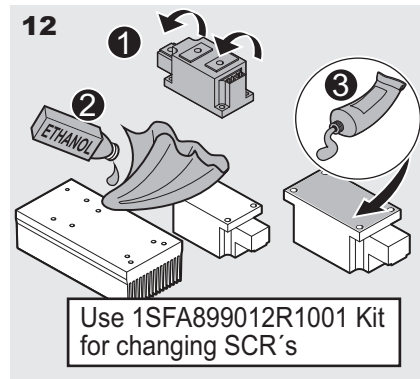
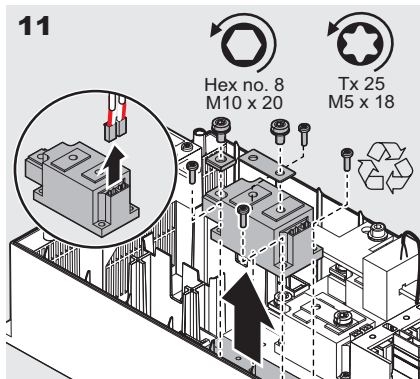
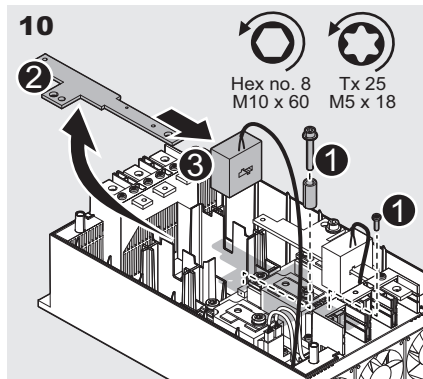
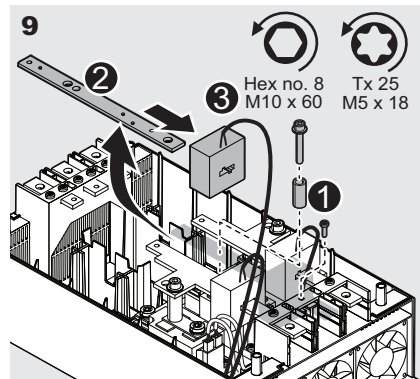
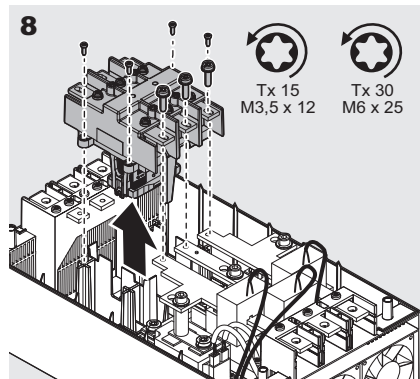
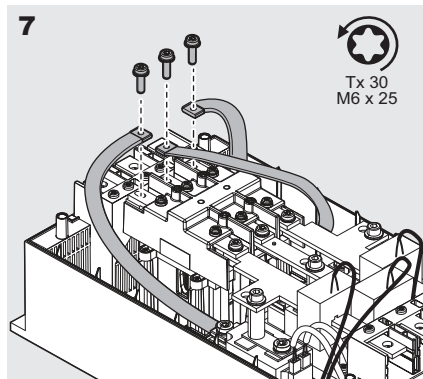
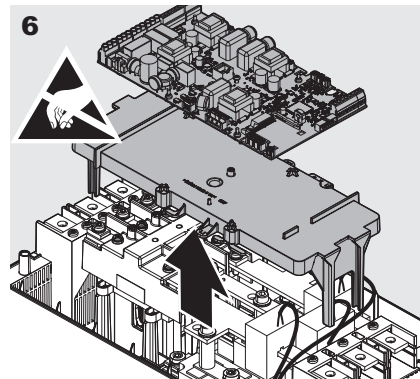
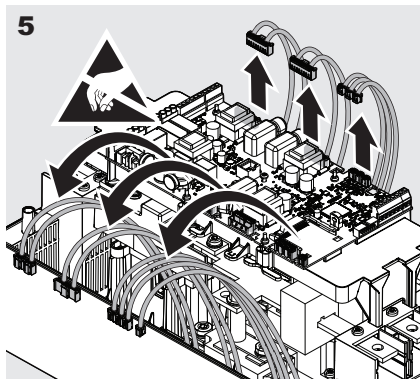
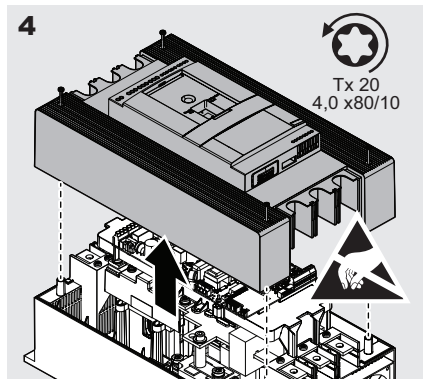
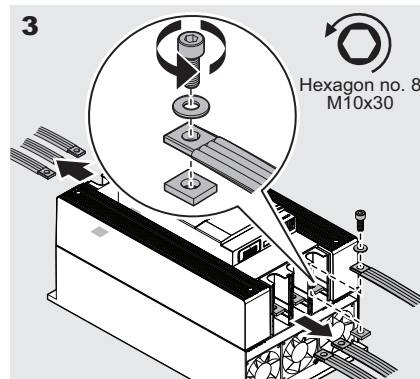
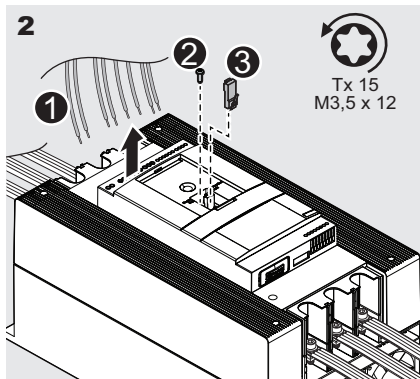
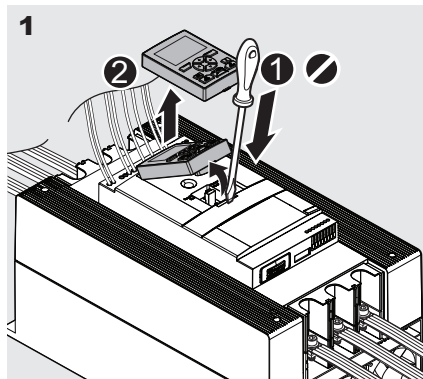
## CAUTION

Always make sure that the power supply is switched off before carrying out installation or maintenance on the Softstarter.



## WARNING

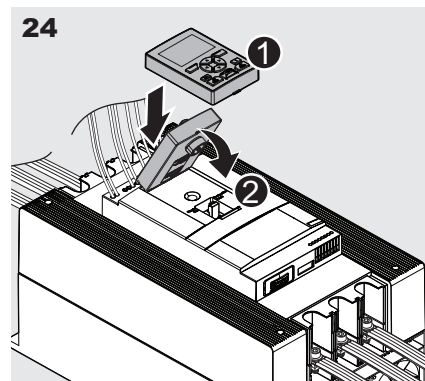
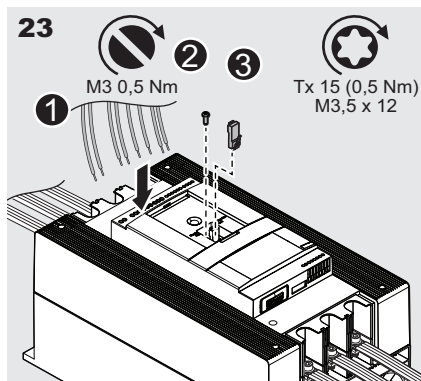
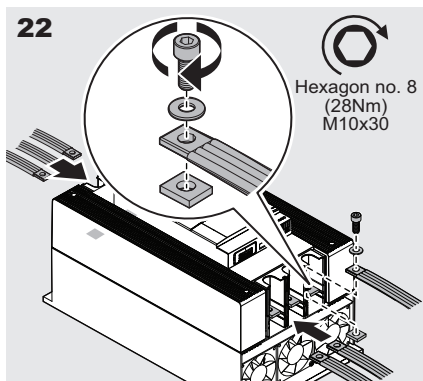
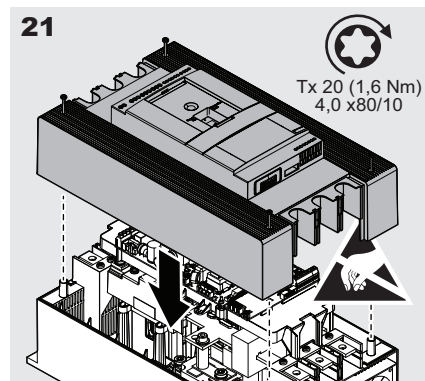
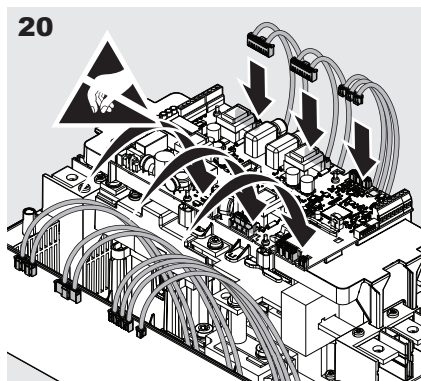
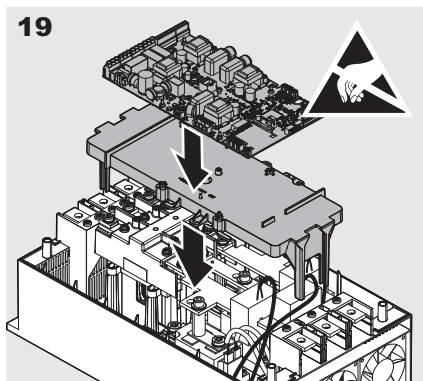
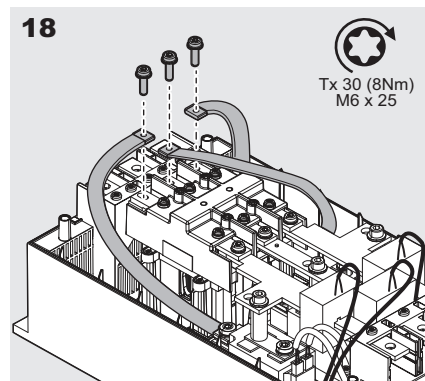
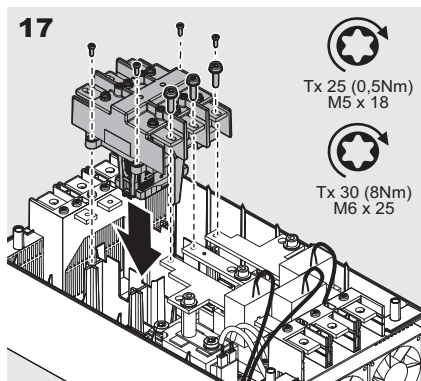
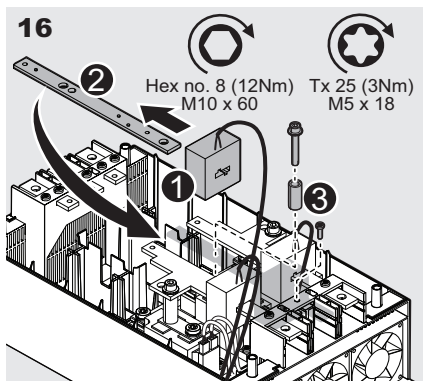
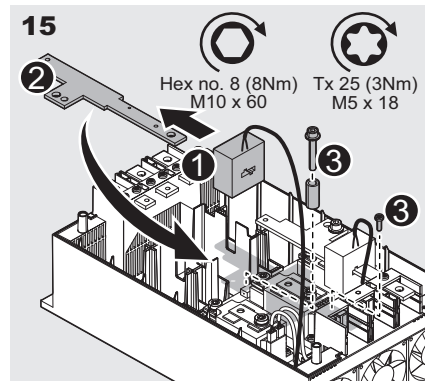
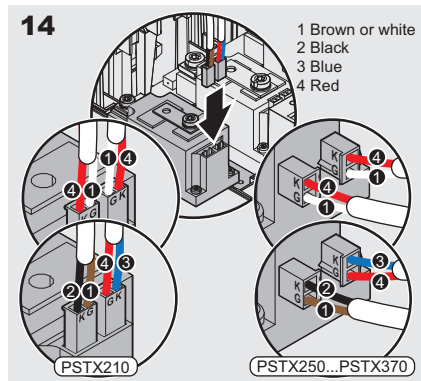
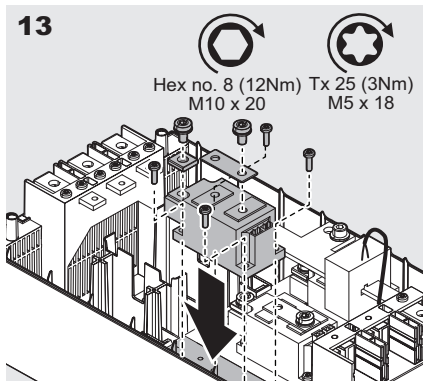
When performing maintenance on the Softstarter, an antistatic strap must be used. The antistatic strap should be worn on the wrist, and be connected to an electrical ground, to prevent electrostatic discharge (ESD) damage to the Softstarter.



Use 1SFA899012R1001 Kit for changing SCR's

# Service instruction - Replace the SCR's

PSTX210...PSTX370









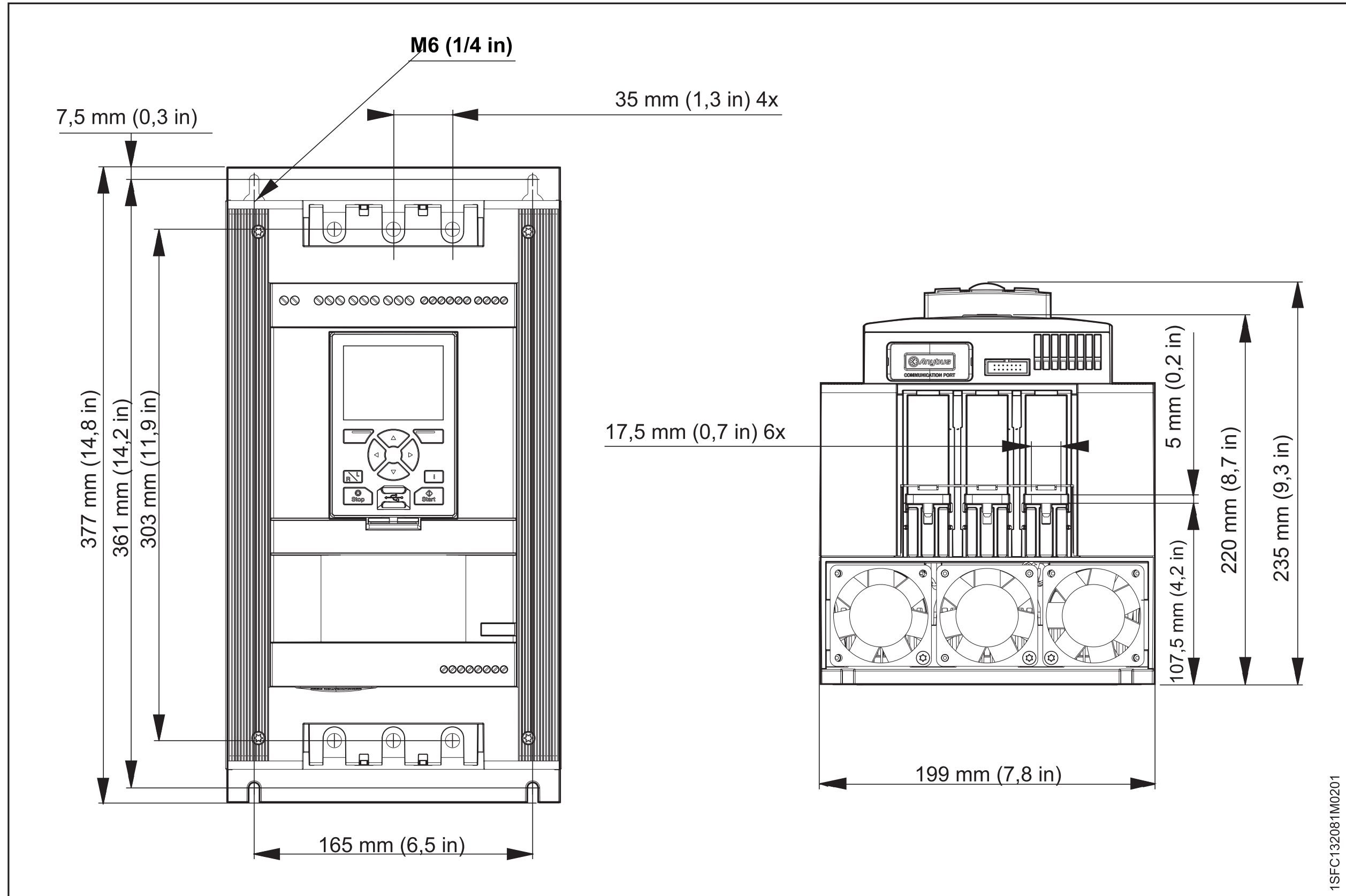
---

**ABB AB, Control Products**  
SE-721 61 Västerås  
Sweden  
E-mail: [sales@se.abb.com](mailto:sales@se.abb.com)

[new.abb.com/low-voltage/products/softstarters](http://new.abb.com/low-voltage/products/softstarters)



PSTX 142...170 - 1SFB536268G1011



Dimensions PSTX142...170

1SFC132081M0201

THIS PAGE LEFT BLANK

## Product specifications

# Eaton HFD3200

Catalog Number: HFD3200

Eaton Series C complete molded case circuit breaker, F-frame, HFD, Complete breaker, Fixed thermal, Fixed magnetic trip type, Three-pole, 200 A, 600 Vac, 250 Vdc, Load side, 50/60 Hz

### General specifications



<b>Product Name</b>	<b>Catalog Number</b>
Eaton Series C complete molded case circuit breaker	HFD3200
	UPC
	786679015438

<b>Product Length/Depth</b>	<b>Product Height</b>
3.38 in	4.13 in

<b>Product Width</b>	<b>Product Weight</b>
4.13 in	4.4 lb

<b>Warranty</b>	<b>Certifications</b>
Eaton Selling Policy 25-000, one (1) year UL Listed from the date of installation of the Product or eighteen (18) months from the date of shipment of the Product, whichever occurs first.	

## Product specifications

### Series

Series C

### Interrupt rating

65 kAIC at 480 Vac

100 kAIC at 240 Vac

### Frame

F

### Circuit breaker type

HFD

### Frequency rating

50 to 60 Hz

### Circuit breaker frame type

Complete breaker

### Terminals

Load side

### Voltage rating

600 Vac, 250 Vdc

### Amperage Rating

200 A

### Trip Type

Fixed thermal, fixed magnetic

### Number of poles

Three-pole

## Resources

### Application notes

UL listed 100%-rated molded case circuit breakers

Application of Multi-Wire Terminals for Molded Case Circuit Breakers

Application of Tap Rules to Molded Case Breaker Terminals

### Brochures

Circuit breaker motor operators product aid

StrandAble terminals product aid

Current limiting Series C molded case circuit breakers product aid

Motor protection circuit breakers product aid

Multi-wire lugs product aid

MOEM MCCB Product Selection Guide

Power metering and monitoring with Modbus RTU product aid

Plug-in adapters for molded case circuit breakers product aid

Counterfeit and Gray Market Awareness Guide

Breaker service centers

### Catalogs

Eaton's Volume 4—Circuit Protection

Molded case circuit breakers catalog

### Drawings

HFD3 3D Inventor

F-frame Molded Case Circuit Breaker Drawing

HFD3 2D PDF

HFD3 3D Model Xchange

Time Current Curves for Series C® F-Frame Circuit Breakers

HFD3 2D Drawing Xchange

### Installation instructions

Installation Instructions for EHD, EDB, EDS, ED, EDH, EDC, FDB, FD, HFD, FDC, HFDDC Circuit Breakers and Molded Case Switches

### Multimedia

Circuit Breakers Explained

Circuit breakers explained

### Specifications and datasheets

Series C J-Frame molded case circuit breakers time current curves

Series C G-Frame molded case circuit breakers time current curves

MOEM MCCB product selection guide

Eaton Specification Sheet - HFD3200

F-Frame 310+ Molded-case circuit breakers 15-225A

Series C F-Frame molded case circuit breakers

[Warranty guides](#)

[Selling Policy 25-000 - Distribution and Control Products and Services](#)

---



Eaton Corporation plc  
Eaton House  
30 Pembroke Road  
Dublin 4, Ireland  
Eaton.com

© 2023 Eaton. All Rights Reserved.

Eaton is a registered trademark.

All other trademarks are property of their respective owners.



[Eaton.com/socialmedia](https://www.eaton.com/socialmedia)

THIS PAGE LEFT BLANK



## Molded Case Circuit Breaker Product Family



## Product Overview

Eaton's molded case circuit breakers are designed to provide circuit protection for low-voltage distribution systems. They are described by NEMA as, "... a device for closing and interrupting a circuit between separable contacts under both normal and abnormal conditions," and furthermore as, "... a breaker assembled as an integral unit in a supporting and enclosing housing of insulating material." The National Electrical Code (NEC) describes them as, "A device designed to open and close a circuit by non-automatic means, and to open the circuit automatically on a predetermined overload of current, without injury to itself when properly applied within its rating."

So designed, Eaton circuit breakers protect conductors against overloads and conductors and connected apparatus, such as motors and motor starters, against short circuits.

In low-voltage distribution systems, there are many varied applications of molded case circuit breakers.

Eaton offers the most comprehensive family of molded case circuit breakers in the industry.

This section of circuit breakers includes:

- Thermal-magnetic trip breakers
- Electronic rms trip breakers
- Molded case switches
- Motor circuit protectors
- Current-limiting breakers
- Special application breakers

### Modified Breakers

Eaton breakers can be ordered with internal accessories installed. These modified breakers will be subject to an addition charge.

### Special Calibration

Special non-UL-listed calibrations are available for certain ambient temperatures other than 40 °C and for frequencies other than 50/60 Hz or DC. Reduced interrupting ratings will apply for 400 Hz applications.

## Contents

### Description

Description	Page
Standards and Certifications	V4-T2-262
Quick Reference	V4-T2-263
G-Frame (15–100 Amperes)	V4-T2-266
F-Frame (10–225 Amperes)	V4-T2-280
J-Frame (70–250 Amperes)	V4-T2-298
K-Frame (70–400 Amperes)	V4-T2-306
L-Frame (125–600 Amperes)	V4-T2-319
M-Frame (300–800 Amperes)	V4-T2-331
Motor Circuit Protectors (MCP)	V4-T2-342
Type ELC Current Limiter Attachment (Size 0–4)	V4-T2-353
Current-Limiting Circuit Breaker Module	V4-T2-354
Internal Accessories	V4-T2-357
External Accessories	V4-T2-390



### 50 °C Calibration

Add suffix **V** to catalog Number for complete breaker, listed above, when ordering listed ampere ratings for breakers to be used in 50 °C ambients. (No UL label.)

### Moisture-Fungus Treatment

All circuit breaker cases are molded from glass-polyester which does not support the growth of fungus. Any parts which are susceptible to the growth of fungus will require special treatment.

### Freeze-Tested Circuit Breakers

The circuit breakers may be ordered with freeze testing. This option uses special lubrication and mechanical operation is verified at –40 °C.

### Marine Applications

E- to R-Framed circuit breakers can be supplied to meet the following marine specifications:

- U.S. Coast Guard CFR 46; ABS—American Bureau of Shipping; IEEE 45; DNV; Lloyds; and ABS/NVR

These specifications generally require molded case circuit breakers to be supplied with 50 °C ambient, and plug-in adapter kits. When plug-in adapter kits are used, no terminals need be supplied (switchboard applications).

Circuit breakers can also be supplied to meet UL 489 Supplement SA (Marine use) and UL 489 Supplement SB (Naval Use).

UL 489 Supplement SA applies to vessels over 65 feet (19.8 m) in length. Requirements include 40 °C ambient calibration, special labeling, and no use of aluminum conductors or terminals. (No 50 °C.)

- Suffix H08

Or you can choose to add 50 °C ambient but then there is no "UL" mark.

- Suffix VH08

UL 489 Supplement SB requires partial 50 °C ambient calibration, vibration testing, special nameplating and no use of aluminum conductors or terminals. Eaton chooses to always fully calibrate to 50 °C ambient. ("Naval" labeled per UL, and UL now allows 50 °C label here.)

- Suffix VH09

### Certified Test Reports

Eaton breakers can be ordered with certified test reports at the time of order entry. Test report documents the thermal and magnetic or electronic tripping characteristics of the individual breaker. Breaker and test report must be ordered together. Add suffix 12 to breaker catalog number and enter separate line item on order for certified test report.

### Standards and Certifications

Molded case circuit breakers are designed to conform with the following standards:

- Underwriters Laboratories Inc., Standard UL 489, molded case circuit breakers and circuit breaker enclosures
- National Electrical Manufacturers Association (NEMA) Standards Publication No. AB1-1993, molded case circuit breakers
- Australian Standard AS 2184, molded case circuit breakers
- British Standards Institution Standard BS 4752: Part 1, switchgear and control gear Part 1: circuit breakers
- Canadian Standards Association (CSA) Standard C22.2 No. 5, service entrance and branch circuit breakers
- International Electrotechnical Commission Recommendations IEC 60947-2, circuit breakers
- Japanese T-Mark Standard molded case circuit breakers
- South African Bureau of Standards, Standard SABS 156, Standard Specification for molded case circuit breakers
- Swiss Electro-Technical Association Standard SEV 157-1, safety regulations for circuit breakers
- Union Technique de l'Electricite Standard NFC 63-120, low-voltage switchgear and control gear circuit breaker requirements
- Verband Deutscher Elektrotechniker (Association of German Electrical Engineers) Standard VDE 0660, low-voltage switchgear and control gear, circuit breakers

Conformance with these standards satisfies most local and international codes, assuming user acceptability and simplified application.

Molded case circuit breakers equal or exceed Federal Specification Classification W-C-375b requirements for the particular class associated with the circuit breaker frame being considered.

Open breakers do not have service entrance ratings. Service entrance rating is part of the enclosure.



# 2.4

## Molded Case Circuit Breakers

### Series C

2

#### F-Frame

Circuit Breaker Type	Continuous Ampere Rating at 40 °C	No. of Poles	Volts		Type of Trip <sup>①</sup>	Federal Specification W-C-375b	UL Listed Interrupting Ratings (rms Symmetrical Amperes)								Page Number
			AC	DC			AC (kA)				DC (kA) <sup>②</sup>				
							120	120/240	240	277	480	600	125	250	
EDB	100–225	2, 3	240	125	N.I.T.U.	—	—	—	22	—	—	—	10	—	V4-T2-280
EDS	100–225	2, 3	240	125	N.I.T.U.	—	—	—	42	—	—	—	10	—	V4-T2-280
ED	15–225	2, 3	240	125	N.I.T.U.	12b	—	—	65	—	—	—	10	—	V4-T2-280
EDH	100–225	2, 3	240	125	N.I.T.U.	14b	—	—	100	—	—	—	10	—	V4-T2-280
EDC	100–225	2, 3	240	125	N.I.T.U.	1	—	—	200	—	—	—	10	—	V4-T2-280
EHD	15–100	1	277	125	N.I.T.U.	13a	—	—	—	14	—	—	10	—	V4-T2-280
EHD	15–100	2, 3	480	250	N.I.T.U.	13b	—	—	18	—	14	—	10	—	V4-T2-280
FDB	15–150	2, 3	600	250	N.I.T.U.	18a	—	—	18	—	14	14	10	—	V4-T2-280
FDB	15–150	4	600	250	N.I.T.U.	③	—	—	18	—	14	14	10	—	V4-T2-280
FD	15–150	1	277	125	N.I.T.U.	13a	—	—	—	35	—	—	10	—	V4-T2-280
FD	15–225	2, 3	600	250	N.I.T.U.	22a	—	—	65	—	35	18	10	—	V4-T2-280
FD	15–225	4	600	250	N.I.T.U.	③	—	—	65	—	35	18	10	—	V4-T2-280
FDE	15–225	3	600	—	N.I.T.U.	—	—	—	65	—	35	18	—	—	V4-T2-280
HFD	15–150	1	277	125	N.I.T.U.	13a	—	—	—	65	—	—	10	—	V4-T2-280
HFD	15–225	2,3	600	250	N.I.T.U.	22a	—	—	100	—	65	25	—	22	V4-T2-280
HFD	15–225	4	600	250	N.I.T.U.	③	—	—	100	—	65	25	—	22	V4-T2-280
HFDE	15–225	3	600	—	N.I.T.U.	—	—	—	100	—	65	25	—	—	V4-T2-280
FDC <sup>④</sup>	15–225	2, 3	600	250	N.I.T.U.	24a	—	—	200	—	100	35	—	22	V4-T2-280
FDC <sup>④</sup>	15–225	4	600	250	N.I.T.U.	③	—	—	200	—	100	35	—	22	V4-T2-280
FDCE <sup>④⑤</sup>	15–225	3	600	—	N.I.T.U.	—	—	—	200	—	100	25	—	—	V4-T2-280

#### Notes

- ① N.I.T.U. is non-interchangeable trip unit and I.T.U. is interchangeable trip unit.
- ② Two-pole circuit breaker, or two poles of three-pole circuit breaker at 250 Vdc.
- ③ Not defined in W-C-375b.
- ④ Current limiting.
- ⑤ Check with Eaton for availability.

**Typical F-Frame Breaker**  
**F-Frame Breaker with Electronic Trip Unit**



### Contents

<i><b>Description</b></i>	<i><b>Page</b></i>
Product Overview . . . . .	<b>V4-T2-261</b>
Standards and Certifications . . . . .	<b>V4-T2-262</b>
Quick Reference . . . . .	<b>V4-T2-263</b>
G-Frame (15–100 Amperes) . . . . .	<b>V4-T2-266</b>
F-Frame (10–225 Amperes)	
Catalog Number Selection . . . . .	<b>V4-T2-281</b>
Product Selection . . . . .	<b>V4-T2-283</b>
Accessories . . . . .	<b>V4-T2-294</b>
Technical Data and Specifications . . . . .	<b>V4-T2-295</b>
Dimensions and Weights . . . . .	<b>V4-T2-297</b>
J-Frame (70–250 Amperes) . . . . .	<b>V4-T2-298</b>
K-Frame (70–400 Amperes) . . . . .	<b>V4-T2-306</b>
L-Frame (125–600 Amperes) . . . . .	<b>V4-T2-319</b>
M-Frame (300–800 Amperes) . . . . .	<b>V4-T2-331</b>
Motor Circuit Protectors (MCP) . . . . .	<b>V4-T2-342</b>
Type ELC Current Limiter Attachment (Size 0–4) . . . . .	<b>V4-T2-353</b>
Current-Limiting Circuit Breaker Module . . . . .	<b>V4-T2-354</b>
Internal Accessories . . . . .	<b>V4-T2-357</b>
External Accessories . . . . .	<b>V4-T2-390</b>

### F-Frame (10–225 Amperes)

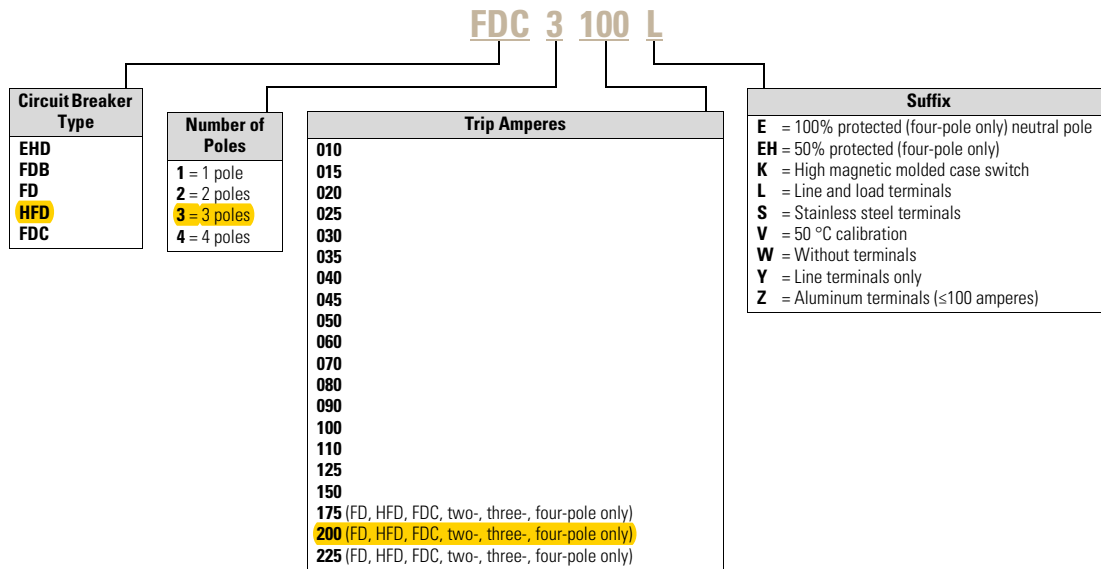
#### Product Description

- All Eaton’s F-Frame circuit breakers are HACR rated
- All circuit breakers 10 through 30 amperes are suitable for HID (high intensity discharge) use
- All F-Frame circuit breakers are suitable for reverse feed use

**Catalog Number Selection**

This information is presented only as an aid to understanding catalog numbers. It is not to be used to build catalog numbers for circuit breakers or trip units.

**FD-Frame Circuit Breakers with Thermal-Magnetic Trip Unit Technology**



# 2.4

## Molded Case Circuit Breakers

### Series C

2

#### Type HFD Thermal-Magnetic Circuit Breakers with Non-Interchangeable Trip Units (Includes Terminals on Load End Only)

Maximum Continuous Ampere Rating at 40 °C	277 Vac Maximum, 125 Vdc 65 kAIC at 277 Vac	600 Vac Maximum, 250 Vdc 65 kAIC at 480 Vac		
	Single-Pole Catalog Number	Two-Pole Catalog Number	Three-Pole	Four-Pole Catalog Number
15	HFD1015 ①	HFD2015	HFD3015	HFD4015
20	HFD1020 ①	HFD2020	HFD3020	HFD4020
25	HFD1025	HFD2025	HFD3025	HFD4025
30	HFD1030	HFD2030	HFD3030	HFD4030
35	HFD1035	HFD2035	HFD3035	HFD4035
40	HFD1040	HFD2040	HFD3040	HFD4040
45	HFD1045	HFD2045	HFD3045	HFD4045
50	HFD1050	HFD2050	HFD3050	HFD4050
60	HFD1060	HFD2060	HFD3060	HFD4060
70	HFD1070	HFD2070	HFD3070	HFD4070
80	HFD1080	HFD2080	HFD3080	HFD4080
90	HFD1090	HFD2090	HFD3090	HFD4090
100	HFD1100	HFD2100	HFD3100	HFD4100
110	HFD1110	HFD2110	HFD3110	HFD4110
125	HFD1125	HFD2125	HFD3125	HFD4125
150	HFD1150	HFD2150	HFD3150	HFD4150
175	—	HFD2175	HFD3175	HFD4175
200	—	HFD2200	HFD3200	HFD4200
225	—	HFD2225	HFD3225	HFD4225

**Note**

① UL listed for SWD applications, see NEC Article 240.83(d).

## Technical Data and Specifications

### UL 489 Interrupting Capacity Ratings

Circuit Breaker Type	Number of Poles	Interrupting Capacity (kA Symmetrical Amperes)					
		Volts AC (50/60 Hz)				Volts DC <sup>①</sup>	
		240	277	480	600	125	250 <sup>②③</sup>
EDB	2, 3	22	—	—	—	10	—
EDS	2, 3	42	—	—	—	10	—
ED	2, 3	65	—	—	—	10	—
EDH	2, 3	100	—	—	—	10	—
EDC	2, 3	200	—	—	—	10	—
EHD	1	—	4	—	—	10	—
	2, 3	18	—	14	—	—	10
FDB	2, 3, 4	18	—	14	14	—	10
FD	1	—	35	—	—	10	—
	2, 3, 4	65	—	35	18	—	10
FDE <sup>④</sup>	3	65	—	35	18	—	—
HFD	1	—	65	—	—	10	—
	2, 3, 4	100	—	65	25	—	22
HFDE <sup>④</sup>	3	100	—	65	25	—	—
FDC <sup>⑤</sup>	2, 3, 4	200	—	100	35	—	22
FDCE <sup>④⑤⑥</sup>	3	200	—	100	25	—	—

### IEC 157-1 (P1) Interrupting Capacity Ratings (P1)

Circuit Breaker Type	Number of Poles	Interrupting Capacity (kA Symmetrical Amperes)				Volts DC <sup>①</sup>	
		Volts AC (50/60 Hz)					
		220, 240	380, 415	440	500	125	250 <sup>②③</sup>
EDB	2, 3	22	—	—	—	10	—
EDS	2, 3	42	—	—	—	10	—
ED	2, 3	65	—	—	—	10	—
EDH	2, 3	100	—	—	—	10	—
EDC	2, 3	200	—	—	—	10	—
EHD	1	—	14	—	—	10	—
	2, 3	18	—	14	—	—	10
FDB	2, 3, 4	18	14	14	14	—	10
FD	1	35	—	—	—	10	—
	2, 3, 4	65	35	35	18	—	10
HFD	1	65	—	—	—	10	—
	2, 3, 4	100	65	65	25	—	22
FDC	2, 3, 4	200	100	100	35	—	22

### UL 489 Current-Limiting Data

Frame	Circuit	I <sub>p</sub> (kA)	I <sup>2</sup> T (10 <sup>6</sup> A <sup>2</sup> S)
FDC	240 V/200 kA	41.4	1.41
FDC	480 V/100 kA	38.9	2.50
FDC	600 V/35 kA	29.0	3.00

#### Notes

- ① DC ratings apply to substantially non-inductive circuits.
- ② Two-pole circuit breaker, or two poles of three-pole circuit breaker.
- ③ Time constant is 3 milliseconds minimum at 10 kA and 8 milliseconds minimum at 22 kA.
- ④ Electronics available on three-pole only, no DC rating for FDE, HFDE, FDCE.
- ⑤ Current limiting.
- ⑥ Check with Eaton for availability.
- ⑦ Neutral sensor required for four-wire systems if neutral protection is desired; sold separately.

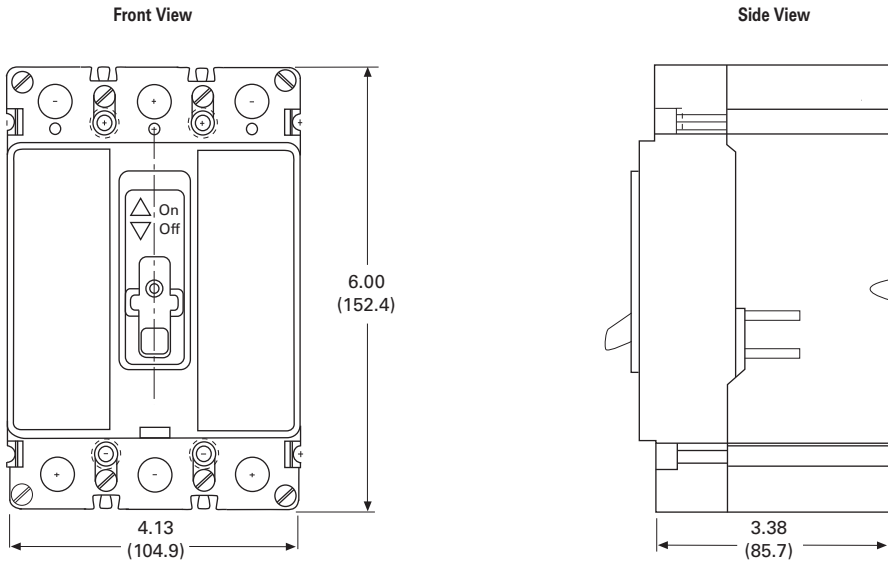
**Dimensions and Weights**

Approximate Dimensions in Inches (mm)

**FD Frame**

Number of Poles	Width	Height	Depth
1	1.38 (35.1)	6.00 (152.4)	3.38 (86.0)
2	2.75 (70.0)	6.00 (152.4)	3.38 (86.0)
3	4.13 (105.0)	6.00 (152.4)	3.38 (86.0)
4	5.50 (139.7)	6.00 (152.4)	3.38 (86.0)

**FD Frame, Three-Pole**



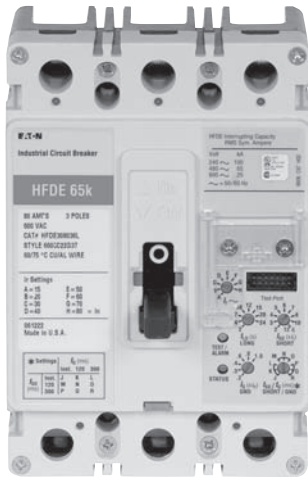
Approximate Shipping Weight Lb (kg)

**FD Frame**

Breaker Type	Number of Poles			
	1	2	3	4
ED, EDB, EDS, EDH, EDC	—	3 (1.4)	4.5 (2.0)	—
EHD, FDB, FD, HFD, FDC	2 (0.9)	3 (1.4)	4.5 (2.0)	6 (2.7)
FDE, HFDE, FDCE	—	—	4.5 (2.0)	—



# F-Frame circuit breaker 10–225 amperes



## Product description

- All of Eaton's F-Frame circuit breakers are HACR rated
- All F-Frame thermal-magnetic circuit breakers 10–50A are suitable for HID (high intensity discharge) use
- All F-Frame circuit breakers are suitable for reverse feed use

**Table 1. Frame Trip Ratings**

Frame	Ampere Rating
EDB, EDS, EDH, EDC	100–225
EHD	10–100
FDB	10–150
ED, HFD, FDC, HFDDC	15–225
FD	15–225
FDE, HFDE, FDCE ①	80, 160, 225

① The 80A FDE, HFDE, FDCE is adjustable from 15–80A.  
The 160A FDE, HFDE, FDCE is adjustable from 60–160A.  
The 225A FDE, HFDE, FDCE is adjustable from 100–225A.



Powering Business Worldwide

**Table 2. UL® 489 Interrupting Capacity Ratings**

Circuit Breaker Type	Number of Poles	Trip Type ①	Interrupting Capacity (Symmetrical Amperes)					
			Volts AC (50/60 Hz)				Volts DC	
			240	277	480	600	125	250 ②③
EDB	2, 3	T/M N.I.T.	22,000	—	—	—	10,000	—
EDS	2, 3		42,000	—	—	—	10,000	—
ED	2, 3	T/M N.I.T.	65,000	—	—	—	10,000	—
EDH	2, 3		100,000	—	—	—	10,000	—
EDC ④	2, 3		200,000	—	—	—	10,000	—
EHD	1 2, 3	T/M N.I.T.	— 18,000	14,000 —	— 14,000	— —	10,000 —	— 10,000
FDB	2, 3, 4	T/M N.I.T.	18,000	—	14,000	14,000	—	10,000
FD	1 2, 3, 4	T/M N.I.T.	— 65,000	35,000 —	— 35,000	— 18,000	10,000 —	— 10,000
HFD	1 2, 3, 4	T/M N.I.T.	— 100,000	65,000 —	— 65,000	— 25,000	10,000 —	— 22,000
FDC ④	2, 3, 4	T/M N.I.T.	200,000	—	100,000	35,000	—	22,000
HFDDC ⑤	3	T/M N.I.T.	—	—	—	—	—	50,000 ⑥
FDE	3	Electronic N.I.T.	65,000	—	35,000	18,000	—	—
HFDE	3	Electronic N.I.T.	100,000	—	65,000	25,000	—	—
FDCE ④	3	Electronic N.I.T.	200,000	—	100,000	25,000	—	—

① N.I.T. is non-interchangeable trip unit. T/M is thermal-magnetic. For DC applications, magnetics are approximately 40% higher.

② Two-pole circuit breaker, or two poles of three-pole circuit breaker.

③ Time constant is 3 milliseconds minimum at 10 kA and 8 milliseconds minimum at 22 kA.

④ Current limiting.

⑤ HFDDC is UL only and is not tested to other standards.

⑥ Interrupting rating is 42,000A at 600 Vdc with three-poles in series.

**Table 3. Line and Load Terminals**

Maximum Breaker Amperes	Terminal Body Material ①	Wire Type	AWG Wire Range	Metric Wire Range (mm²)	Catalog Number (Package of 3 Terminals)
<b>Standard Pressure Type Terminals</b>					
20 (EHD)	Steel	Cu/Al	(1) #14–#10	2.5–4	<b>3T20FB</b>
100	Steel	Cu/Al	(1) #14–1/0	2.5–50	<b>3T100FB</b>
150	Aluminum	Cu/Al	(1) #4–4/0	25–95	<b>3TA150FB</b>
225	Aluminum	Cu/Al	(1) #4–4/0	25–95	<b>3TA225FD</b>
<b>Optional Pressure Terminals</b>					
50	Aluminum	Cu/Al	(1) #14–#4	2.5–16	<b>3TA50FB</b>
100	Aluminum	Cu/Al	(1) #14–1/0	2.5–50	<b>3TA100FD</b>
225	Aluminum	Cu/Al	(1) #6–300 kcmil	16–150	<b>3TA225FDK ②</b>

① UL listed for use with copper or aluminum conductors as noted.

② Use only on 175–225A. Includes terminal shield and increases height.

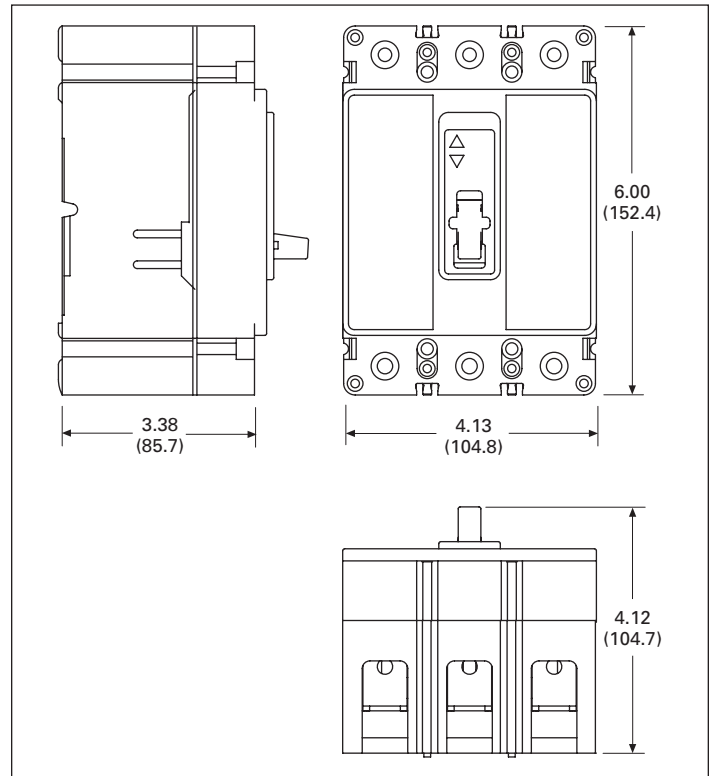
**Table 4. Approximate Shipping Weight in Lbs (kg)**

Circuit Breaker Type	Number of Poles			
	1	2	3	4
ED, EDB, EDS, EDH, EDC	—	3 (1.4)	4.5 (2.0)	—
EHD, FDB, FD, HFD, HFDDC, FDC	2 (0.9)	3 (1.4)	4.5 (2.0)	6 (2.7)
FDE, HFDE, FDCE	—	—	4.2 (1.9)	—

**Table 5. Dimensions in Inches (mm)**

Dimensions	Number of Poles			
	1	2	3	4
Height	6.00 (152.4)	6.00 (152.4)	6.00 (152.4)	6.00 (152.4)
Width	1.38 (34.8)	2.75 (69.9)	4.13 (104.8)	5.50 (139.7)
Depth	3.38 (85.7)	3.38 (85.7)	3.38 (85.7)	3.38 (85.7)

**Dimensions in inches (mm)**



**Figure 3. Three-Pole F-Frame Breaker**

**Note:** For curves and additional technical information, please visit our Web site at [www.eaton.com](http://www.eaton.com).

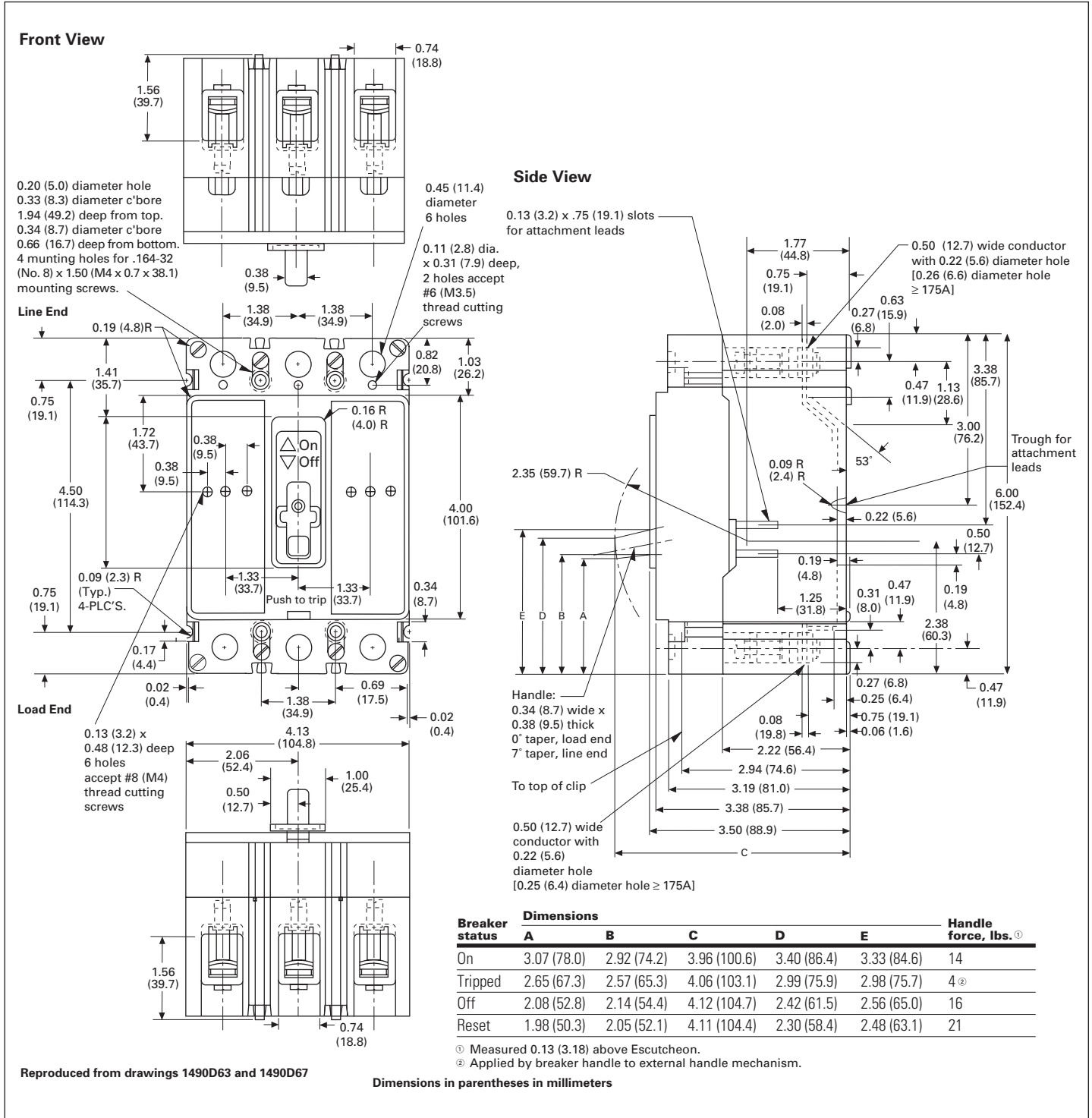


Figure 9. Type FD Three-Pole Outline

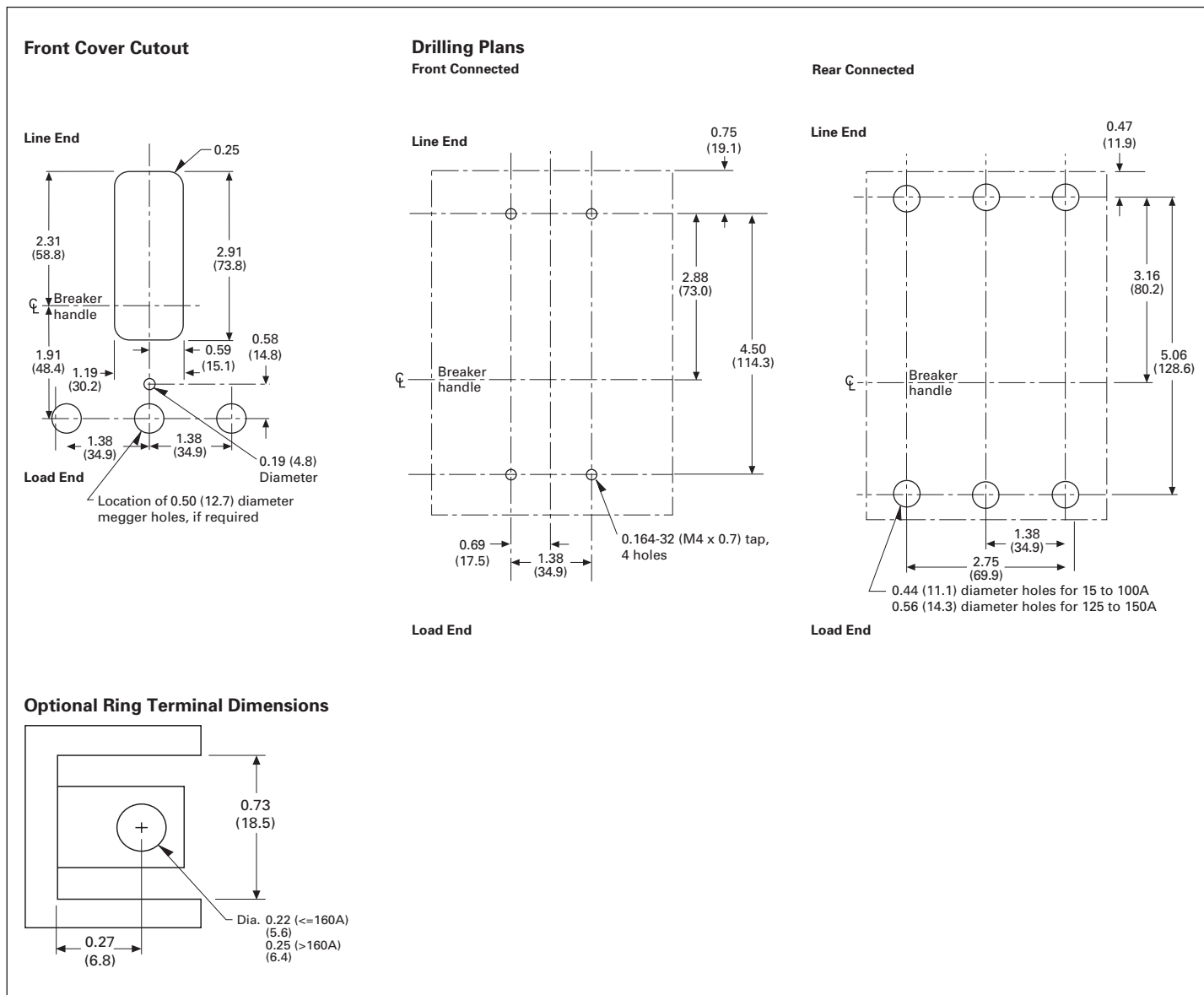


Figure 10. Type FD Three-Pole Outline Drilling Plans

**Eaton Corporation**  
Electrical Sector  
1111 Superior Ave.  
Cleveland, OH 44114  
United States  
877-ETN-CARE (877-386-2273)  
Eaton.com

© 2011 Eaton Corporation  
All Rights Reserved  
Printed in USA  
Publication No. TD01203013E / Z10989  
March 2011



Eaton is a registered trademark  
of Eaton Corporation.

All other trademarks are property  
of their respective owners.

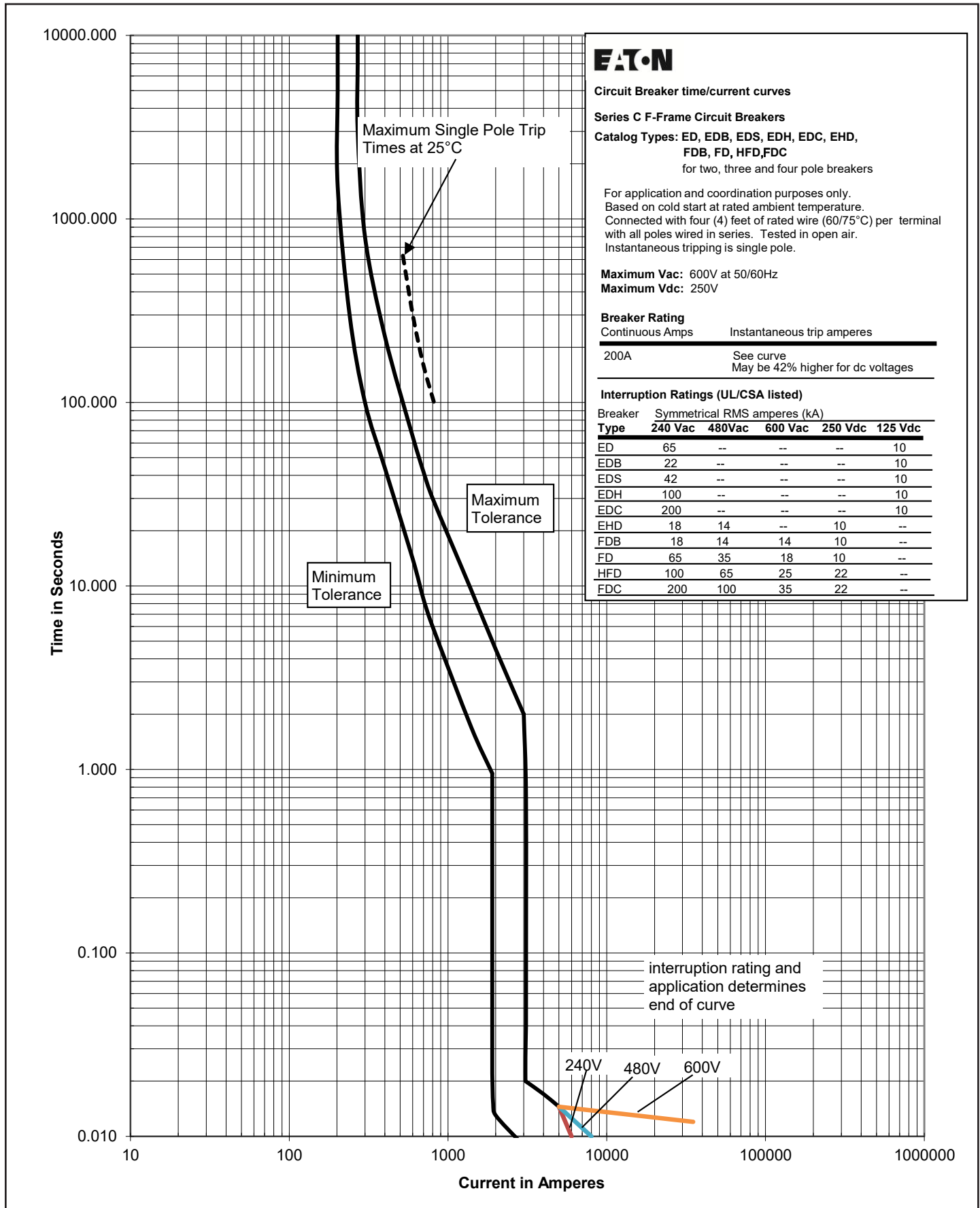


Figure 45. Types ED, EDB, EDS, EDH, EDC, EHD, FDB, FD, HFD, FDC 200A 2, 3, & 4 pole—Curve Number TC012034EN

**Eaton**  
1000 Eaton Boulevard  
Cleveland, OH 44122  
United States  
Eaton.com

© 2018 Eaton  
All Rights Reserved  
Printed in USA  
Publication No. TC01200002E / TBG001366  
March 2018



## Installation Instructions for EHD, EDB, EDS, ED, EDH, EDC, FDB, FD, HFD, FDC, HFDDC Circuit Breakers and Molded Case Switches



### Contents

Description	Page
Introduction .....	2
Installation .....	2
Manual Operation .....	4
Inspection and Field Testing .....	4
HFDDC .....	4

---

**⚠ WARNING**

DO NOT ATTEMPT TO INSTALL OR PERFORM MAINTENANCE ON EQUIPMENT WHILE IT IS ENERGIZED. DEATH, SEVERE PERSONAL INJURY OR SUBSTANTIAL PROPERTY DAMAGE CAN RESULT FROM CONTACT WITH ENERGIZED EQUIPMENT. ALWAYS VERIFY THAT NO VOLTAGE IS PRESENT BEFORE PROCEEDING WITH THE TASK, AND ALWAYS FOLLOW GENERALLY ACCEPTED SAFETY PROCEDURES.

EATON IS NOT LIABLE FOR THE MISAPPLICATION OR MISINSTALLATION OF ITS PRODUCTS.

---

The user is cautioned to observe all recommendations, warnings and cautions relating to the safety of personnel and equipment, as well as all general and local health and safety laws, codes, and procedures.

The recommendations and information contained herein are based on Eaton experience and judgment, but should not be considered to be all-inclusive or covering every application or circumstance which may arise. If any questions arise, contact Eaton for further information or instructions.

## 1. Introduction



Figure 1. Model D Series C Circuit Breaker and Molded Case Switches

The F-Frame Series C circuit breakers (Fig. 1) are rated from 15A to 225A (150A for 1 pole versions) continuous current and are available as thermal-magnetic circuit breakers and molded case switches. (Molded case switches are available rated at 100A, 150A, and 225A.) Circuit breakers are listed in accordance with Underwriters Laboratories, Inc. Standard UL489, and satisfy the (P1) requirements of the International Electrotechnical Commission Recommendation No. IEC 157-1. Molded case switches are listed in accordance with UL489. For this publication, the term circuit breaker also includes molded case switches and F-Frame is used to cover all of the circuit breakers and molded case switches associated with this leaflet.

## 2. Installation

The installation procedure consists of inspecting and mounting the circuit breaker, connecting and torquing the line and load terminations, and attaching terminal shields or barriers, when supplied. To install the circuit breaker perform the following steps:

Note: The F-Frame circuit breakers are factory sealed. UL489 requires that internal accessories be installed at the factory. Where local codes and standards permit and UL listing is not required, internal accessories can be field installed. Accessory installation should be done before the circuit breaker is mounted and connected.

Mounting hardware and unmounted terminations (where required) are supplied in separate packages.

2-1. Make sure that the circuit breaker is suitable for the installation by comparing nameplate data with system requirements. Inspect the circuit breaker for completeness and check for damage before mounting.

---

**⚠ WARNING**

BEFORE MOUNTING THE CIRCUIT BREAKER IN AN ELECTRICAL SYSTEM, MAKE SURE THERE IS NO VOLTAGE PRESENT WHERE WORK IS TO BE PERFORMED. THE VOLTAGES IN ENERGIZED EQUIPMENT CAN CAUSE INJURY OR DEATH.

---

2-2. Depending on the equipment configuration, the circuit breaker can be mounted using different styles of hardware. The following steps describe how to mount the circuit breaker using standard hardware. When special hardware is needed (for example, with the electrical operator), the instruction leaflet describing the accessory also describes the special mounting arrangements.

Note: Before mounting the circuit breaker, check if the termination devices should be installed first. See terminations instructions.

2-3. To mount the circuit breaker, perform the following steps:

- For individual mounting panels, make sure that mounting panel is predrilled using bolt drilling plan (Fig. 2). For panelboard mounting, only load end support mounting holes are required. For deadfront cover applications make sure panel cover is cut out to correct escutcheon dimensions (Fig.3).

---

**⚠ CAUTION**

DO NOT EXCEED CONNECTOR/BUS CAPACITY IN EATON POWER LINE 3A AND 4 PANELS. USE CONNECTOR KIT KPRL3AFD3 (3-POLE) AND KPRL3AFD2 (2-POLE) IN PANEL TYPE PRL3A AND KPRL4FD (3-POLE) AND KPRL4FD2 (2-POLE) IN PANEL PRL4.

---

- If circuit breaker includes factory installed internal accessories, make sure accessory wiring can be reached when the circuit breaker is mounted.
- Position circuit breaker on mounting surface.
- Install mounting screws, washers, and nuts. Tighten screws firmly, but do not exceed 28 pound-inches (3.16 N.m)

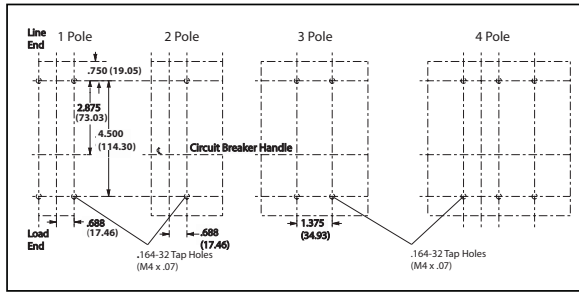


Figure 2. Circuit Breaker Mounting Bolt Drilling Plans

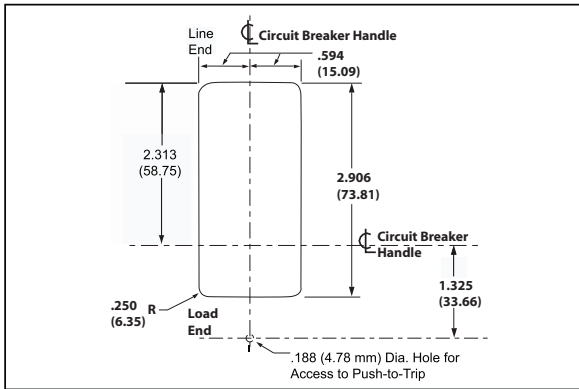


Figure 3. Circuit Breaker EscutcheorDimensions

2-4. If an optional terminal end cover is to be installed with the circuit breaker (usually line end only), it must be positioned before cable is connected to terminals.

**CAUTION**

**WHEN ALUMINUM CONDUCTORS ARE USED, THE APPLICATION OF A SUITABLE JOINT COMPOUND IS RECOMMENDED TO REDUCE THE POSSIBILITY OF TERMINAL OVERHEATING. TERMINAL OVERHEATING CAN CAUSE NUISANCE TRIPPING AND DAMAGE TO THE CIRCUIT BREAKER.**

2-5. After mounting the circuit breaker, line and load terminals and accessory leads should be connected. (See accessory schematic diagram on side of circuit breaker.)

**Note:** If terminal shield or interphase barriers are to be installed on the circuit breaker, install them after the terminals are connected.

2-6. If required, install terminal shield on circuit breaker cover with mounting screws provided.

2-7. If required, install an interphase barrier by sliding barrier into dovetail grooves between terminals.

2-8. After the circuit breaker is installed, check all mounting hardware and terminal connecting hardware for correct torque loading. Torque values for line/load terminals are given in Tables 1, 2, and 3 and on the circuit breaker nameplate.

**Note:** See Section 5 for additional details for HFDDC.

Table 1. Terminal Types

Terminal Catalog Number	Terminal Body Material	Screw Head Type	AWG Wire Range	Metric Wire Range	Wire Type	Torque Value, Lb. in.(N.m)
3TA225FD ①	Aluminum	3/16 Socket Hex	#4-4/0	25-95	Cu/Al	120 (13.6)
3TA225FDM ①	Aluminum	5mm Socket Hex	#4-4/0	25-95	Cu/Al	120 (13.6)
3TA225FDK ①②	Aluminum	5/16 Socket Hex	#6-300	16-150	Cu/Al	275 (31)
3TA100FD ①	Aluminum	Slotted	#14-1/0	2.5-5.0	Cu/Al	See Table 2
3TA50FB ①	Aluminum	Slotted	#14-#4	2.5-16	Cu/Al	See Table 2
3T100FB ①	Steel	Slotted	#14-1/0	2.5-50	Cu/Al	See Table 2
3T150FB ①	Stainless Steel	Slotted	#4-4/0	25-95	Cu Only	See Table 2
3TA150F3 K	Aluminum	5/32 Socket Hex	#14-2	2.5-25	Cu/Al	70 (7.9)
3TA150F6 K	Aluminum	3/32 Socket Hex	#14-6	2.5-10	Cu/Al	25 (2.8)

Note: Terminal wireconnector are UL listed for standard wire sizes as denifed in UL486A and UL486B

① Package of Three

② Individual terminal identified as TA225FD1

Table 2. Terminal Torque Values for Slotted Head

Metric Wire Range	Torque Value N.m	AWG Wire Range	Torque Value, Lb.-In.
2.5-6	3.96	#14-#10	35
10	4.52	#8	40
16-25	5.09	#6-#4	45
35-95	5.65	#3-4/0	50

Table 3. Bolted Connections (Keeper Nut or End Cap)

Termination Catalog Number	Screw Head Type	Nut Thread Size	Torque Value Lb. In. (N.m)
KPR1A/KPR1AM	Upper Supplied	10-32/M5	35 (4.0)
KPEKxxx	Slotted	10-32/M5	35 (4.0)

### 3. Manual Operation

Manual operation of the circuit breaker is controlled by the circuit breaker handle and the PUSH-TO-TRIP button. The circuit breaker handle has three indicated positions, two of which are shown on the cover with raised lettering to indicate ON and OFF. On the sliding handle barrier, ON, OFF, and trip are also shown by a color-coded strip for each circuit breaker handle position: red for ON, white for tripped, and green for OFF. On the sliding handle barrier, ON/OFF is also shown with the international symbols I/O (See Fig. 4.)

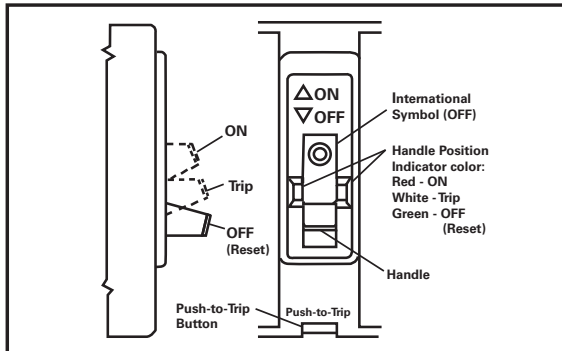


Figure 4. Circuit Breaker Manual Controls.

#### Circuit Breaker Reset

After tripping, the circuit breaker is reset by moving the circuit breaker handle to the extreme OFF position.

**Note:** In the event of a thermal trip, the circuit breaker cannot be reset until the thermal element cools.

#### PUSH-TO-TRIP Button

The PUSH-TO-TRIP button checks the tripping function and is used to periodically exercise the operating mechanism.

### 4. Inspection and Field Testing

Series C molded case circuit breakers are designed to provide years of almost maintenance-free operation. The following procedure describes how to inspect and test a circuit breaker in service.

#### Inspection

Circuit breakers in service should be inspected periodically. The inspection should include the following checks 4-1 thru 4-7.

#### ⚠ WARNING

**BEFORE INSPECTING THE CIRCUIT BREAKER IN AN ELECTRICAL SYSTEM, MAKE SURE THE CIRCUIT BREAKER IS SWITCHED TO THE OFF POSITION AND THERE IS NO VOLTAGE PRESENT WHERE WORK IS TO BE PERFORMED. SPECIAL ATTENTION SHOULD BE PAID TO REVERSE FEED APPLICATIONS TO ENSURE NO VOLTAGE IS PRESENT. THE VOLTAGES IN ENERGIZED EQUIPMENT CAN CAUSE INJURY OR DEATH.**

#### ⚠ CAUTION

**MAKE SURE THAT CLEANING AGENTS OR SOLVENTS USED TO CLEAN THE CIRCUIT BREAKER ARE SUITABLE FOR THE JOB. SOME COMMERCIAL CLEANING AGENTS WILL DAMAGE THE NAME PLATES OR MOLDED PARTS.**

- 4-1. Remove dust, dirt, soot, grease, or moisture from the surface of the circuit breaker using a lint-free dry cloth, brush, or vacuum cleaner. Do not blow debris into circuit breaker. If contamination is found, look for the source and eliminate the problem.
- 4-2. Switch circuit breaker to ON and OFF several times to be sure that the mechanical linkages are free and do not bind. If mechanical linkages are not free, replace circuit breaker.
- 4-3. Press the PUSH-TO-TRIP button to mechanically trip the circuit breaker. Trip, reset, and switch circuit breaker ON several times. If mechanism does not reset each time the circuit breaker is tripped, replace the circuit.
- 4-4. Check base, cover, and operating handle for cracks, chipping, and discoloration. Circuit breakers should be replaced if cracks or severe discoloration is found.
- 4-5. Check terminals and connectors for looseness or signs of overheating. Overheating will show as discoloration, melting, or blistering of conductor insulation, or as pitting or melting of conductor surfaces due to arcing. If there is no evidence of overheating or looseness, do not disturb or tighten the connections. If there is evidence of overheating, terminations should be cleaned or replaced. Before re-energizing the circuit breaker, all terminations and cable should be refurbished to the condition when originally installed.
- 4-6. Check circuit breaker mounting hardware. Tighten if necessary.
- 4-7. Check area where circuit breaker is installed for any safety hazards, including personal safety and fire hazards. Exposure to certain types of chemicals can cause deterioration of electrical connections.

#### Field Testing

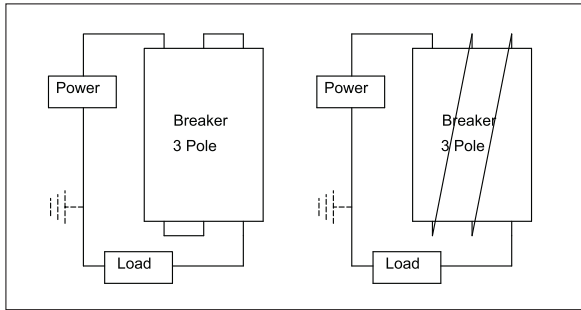
Any field testing should be done in accordance with applicable NEMA Standards.

## 5. HFDDC

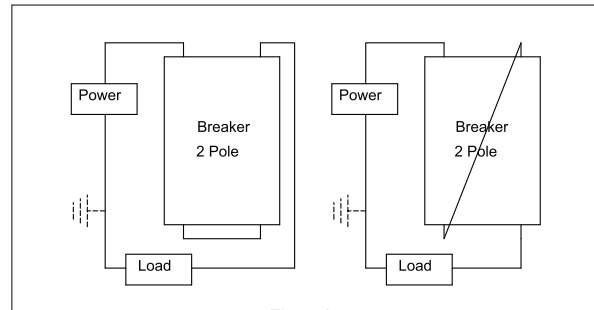
5-1. The HFDDC circuit breakers and switches are qualified for direct current voltages and interruptions with multiple poles wired in series.

5-2. See Figures 5, 6, 7, and 8 for typical wiring configurations. A 3-pole breaker may be wired as a 2-pole.

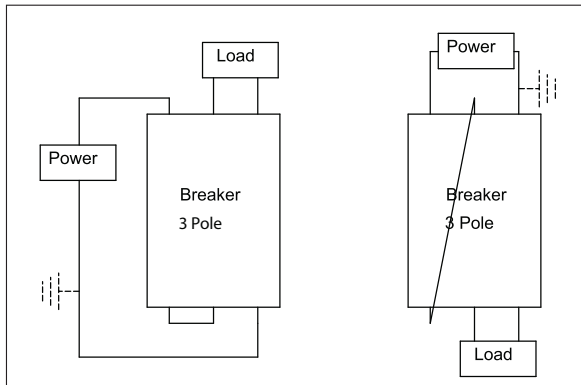
5-3. For grounded insulated load configurations, the interruption rating is based on number of poles in series that break the ungrounded leg of power supply.



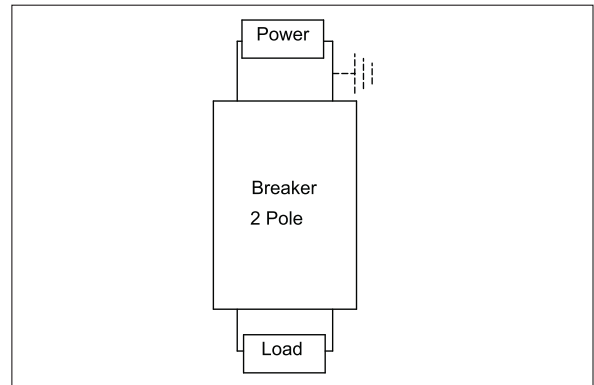
**Figure 5. Load Connected to Power Source. Grounded or Ungrounded Systems.**



**Figure 7. Load Connected to Power Source. Grounded or Ungrounded Systems.**



**Figure 6. Load Isolated from Power Source. Grounded or Ungrounded Systems. If System Voltage Exceeds 300 Vdc, then Ungrounded Systems Only.**



**Figure 8. Load Isolated from Power Source. Grounded or Ungrounded Systems. If System Voltage Exceeds 125 Vdc, then Ungrounded Systems Only.**

# Instruction Leaflet IL 29C1011

Effective December 2013

Installation Instructions for EHD, EDB, EDS, ED, EDH, EDC, FDB, FD, HFD, FDC, HFDDC Circuit Breakers and Molded Case Switches

The instructions for installation, testing, maintenance, or repair herein are provided for the use of the product in general commercial applications and may not be appropriate for use in nuclear applications. Additional instructions may be available upon specific request to replace, amend, or supplement these instructions to qualify them for use with the product in safety-related applications in a nuclear facility.

The information, recommendations, descriptions, and safety notations in this document are based on Eaton's experience and judgment with respect to Retrofitting of Power Breakers. This instructional literature is published solely for information purposes and should not be considered all-inclusive. If further information is required, you should consult an authorized Eaton sales representative.

The sale of the product shown in this literature is subject to the terms and conditions outlined in appropriate Eaton selling policies or other contractual agreement between the parties. This literature is not intended to and does not enlarge or add to any such contract. The sole source governing the rights and remedies of any purchaser of this equipment is the contract between the purchaser and Eaton.

**NO WARRANTIES, EXPRESSED OR IMPLIED, INCLUDING WARRANTIES OF FITNESS FOR A PARTICULAR PURPOSE OR MERCHANTABILITY, OR WARRANTIES ARISING FROM COURSE OF DEALING OR USAGE OF TRADE, ARE MADE REGARDING THE INFORMATION, RECOMMENDATIONS, AND DESCRIPTIONS CONTAINED HEREIN.**

In no event will Eaton be responsible to the purchaser or user in contract, in tort (including negligence), strict liability or otherwise for any special, indirect, incidental or consequential damage or loss whatsoever, including but not limited to damage or loss of use of equipment, plant or power system, cost of capital, loss of power, additional expenses in the use of existing power facilities, or claims against the purchaser or user by its customers resulting from the use of the information, recommendations and description contained herein.

**Eaton Corporation**  
Electrical Group  
1000 Cherrington Parkway  
Moon Township, PA 15108  
United States  
877-ETN-CARE (877-386-2273)  
Eaton.com

© 2013 Eaton Corporation  
All Rights Reserved  
Printed in Dominican Republic  
Publication No. IL29C1011 / TBG000544  
Part No. 6620C41H09  
December 2013



Eaton is a registered trademark of Eaton Corporation.

All other trademarks are property of their respective owners.

## **Domestic U.S.A. General Terms and Conditions of Sale for Distribution and Control Products and Services**

---

**Terms and Conditions of Sale.** The Terms and Conditions of Sale set forth herein, and any supplements which may be attached hereto, constitute the full and final expression of the contract for the sale of products or services ("Product(s)" or "Services") by Eaton Corporation ("Seller") to the Buyer, and supersedes all prior quotations, purchase orders, correspondence or communications, whether written or oral, between the Seller and the Buyer. Notwithstanding any contrary language in the Buyer's purchase order, correspondence or other form of acknowledgment, Buyer shall be bound by these Terms and Conditions of Sale when it sends a purchase order or otherwise indicates acceptance of this contract, or when it accepts delivery from Seller of the Products or Services. THE CONTRACT FOR SALE OF THE PRODUCTS OR SERVICES IS EXPRESSLY LIMITED TO THE TERMS AND CONDITIONS OF SALE STATED HEREIN. ANY ADDITIONAL OR DIFFERENT TERMS PROPOSED BY BUYER ARE REJECTED UNLESS EXPRESSLY AGREED TO IN WRITING BY SELLER. No contract shall exist except as herein provided.

**Complete Agreement.** All Seller documents referenced in these Terms and Conditions of Sale are hereby incorporated by reference into the terms herein. No amendment or modification hereto nor any statement, representation or warranty not contained herein shall be binding on the Seller unless made in writing by an authorized representative of the Seller. Prior dealings, usage of the trade or a course of performance shall not be relevant to determine the meaning of this contract even though the accepting or acquiescing party had knowledge of the nature of the performance and opportunity for objection.

**Quotations.** A written quotation is valid for 30 days from its date unless otherwise stated in the quotation or terminated sooner by notice. Verbal quotations, unless accepted, expire the same day they are made. A complete signed order must be received by Seller within 20 calendar days of notification of award, otherwise the price and shipment will be subject to re-negotiation.

### **TERMINATION AND CANCELLATION**

**Products.** Any order may be terminated by the Buyer only by written notice and upon payment of reasonable termination charges, including all progress billings and all incurred direct manufacturing costs.

**Services.** Any order may be terminated by the Buyer only by written notice and upon payment of reasonable termination charges including all costs plus profit. Seller shall have the right to cancel any order at any time by written notice if Buyer breaches any of the terms hereof, becomes the subject of any proceeding under state or federal law for the relief of debtors, or otherwise becomes insolvent or bankrupt, generally does not pay its debts as they become due or makes an assignment for the benefit of creditors.

**Prices.** All prices are subject to change without notice. In the event of a price change, the effective date of the change will be the date of the new price or discount sheet, letter or telegram. All quotations made or orders accepted after the effective date will be on the new basis. For existing orders, the price of the unshipped portion of an order will be the price in effect at time of shipment.

**Price Policy – Products and Services.** When prices are quoted as firm for quoted shipment, they are firm provided the following conditions are met:

1. The order is released with complete engineering details.
2. Shipment of Products is made, and Services purchased are provided within the quoted lead time.
3. When drawings for approval are required for any Products, the drawings applicable to those Products must be returned within 30\* calendar days from the date of the original mailing of the drawings by Seller. The return drawings must be released for manufacture and shipment and must be marked "APPROVED" or "APPROVED AS NOTED." Drawing re-submittals which are required for any other reason than to correct Seller errors will not extend the 30-day period.

If the Buyer initiates or in any way causes delays in shipment, provision of Services or return of approval drawings beyond the periods stated above, the price of the Products or Services will be increased 1% per month or fraction thereof up to a maximum of 18 months from the date of the Buyer's order. For delays resulting in shipment or provision of Services beyond 18 months from the date of the Buyer's order, the price must be renegotiated.

**Price Policy – BLS.** Refer to Price Policy 25-050.

**Minimum Billing.** Orders less than \$1,000 will be assessed a shipping and handling charge of 5% of the price of the order, with a minimum charge of \$25.00 unless noted differently on Product discount sheets.

**Taxes.** The price does not include any taxes. Buyer shall be responsible for the payment of all taxes applicable to, or arising from, the transaction, the Products, its sale, value or use, or any Services performed in connection therewith regardless of the person or entity actually taxed.

### **TERMS OF PAYMENT**

**Products.** Acceptance of all orders is subject to the Buyer meeting Seller's credit requirements. Terms of payment are subject to change for failure to meet such requirements. Seller reserves the right at any time to demand full or partial payment before proceeding with a contract of sale as a result of changes in the financial condition of the Buyer. Terms of Payment are either Net 30 days from the date of invoice of each shipment or carry a cash discount based on Product type. Specific payment terms for Products are outlined in the applicable Product discount schedules.

**Services.** Terms of payment are net within 30 days from date of invoice for orders amounting to less than \$50,000.00. Terms of payment for orders exceeding \$50,000.00 shall be made according to the following:

1. Twenty percent (20%) of order value with the purchase order payable 30 days from date of invoice.

---

\* 60 days for orders through contractors to allow time for their review and approval before and after transmitting them to their customers.

2. Eighty percent (80%) of order value in equal monthly payments over the performance period payable 30 days from date of invoice.

Except for work performed (i) under a firm fixed price basis or (ii) pursuant to terms of a previously priced existing contract between Seller and Buyer, invoices for work performed by Seller shall have added and noted on each invoice a charge of 3% (over and above the price of the work) which is related to Seller compliance with present and proposed environmental, health and safety regulations associated with prescribed requirements covering hazardous materials management and employee training, communications, personal protective equipment, documentation and record keeping associated therewith.

**Adequate Assurances.** If, in the judgment of Seller, the financial condition of the Buyer, at any time during the period of the contract, does not justify the terms of payment specified, Seller may require full or partial payment in advance.

**Delayed Payment.** If payments are not made in accordance with these terms, a service charge will, without prejudice to the right of Seller to immediate payment, be added in an amount equal to the lower of 1.5% per month or fraction thereof or the highest legal rate on the unpaid balance.

**Freight.** Freight policy will be listed on the Product discount sheets, or at option of Seller one of the following freight terms will be quoted.

**F.O.B. – P/S – Frt./Ppd. and Invoiced.** Products are sold F.O.B. point of shipment freight prepaid and invoiced to the Buyer.

**F.O.B. – P/S – Frt./Ppd. and Allowed.** Products sold are delivered F.O.B. point of shipment, freight prepaid and included in the price.

**F.O.B. Destination – Frt./Ppd. and Allowed.** At Buyer's option, Seller will deliver the Products F.O.B. destination freight prepaid and 2% will be added to the net price. The term "freight prepaid" means that freight charges will be prepaid to the accessible common carrier delivery point nearest the destination for shipments within the United States and Puerto Rico unless noted differently on the Product discount sheets. For any other destination, contact Seller's representative.

**Shipment and Routing.** Seller shall select the point of origin of shipment, the method of transportation, the type of carrier equipment and the routing of the shipment. If the Buyer specifies a special method of transportation, type of carrier equipment, routing or delivery requirement, Buyer shall pay all special freight and handling charges. When freight is included in the price, no allowance will be made in lieu of transportation if the Buyer accepts shipment at factory, warehouse or freight station or otherwise supplies its own transportation.

**Risk of Loss.** Risk of loss or damage to the Products shall pass to Buyer at the F.O.B. point.

**Concealed Damage.** Except in the event of F.O.B. destination shipments, Seller will not participate in any settlement of claims for concealed damage. When shipment has been made on an F.O.B. destination basis, the Buyer must unpack immediately and, if damage is discovered, must:

1. Not move the Products from the point of examination.
2. Retain shipping container and packing material.
3. Notify the carrier in writing of any apparent damage.
4. Notify Seller representative within 72 hours of delivery.
5. Send Seller a copy of the carrier's inspection report.

**Witness Tests/Customer Inspection.** Standard factory tests may be witnessed by the Buyer at Seller's factory for an additional charge calculated at the rate of \$2,500 per day (not to exceed eight (8) hours) per Product type. Buyer may final-inspect Products at the Seller's factory for \$500 per day per Product type.

Witness tests will add one (1) week to the scheduled shipping date. Seller will notify Buyer fourteen (14) calendar days prior to scheduled witness testing or inspection. In the event Buyer is unable to attend, the Parties shall mutually agree on a rescheduled date. However, Seller reserves the right to deem the witness tests waived with the right to ship and invoice Products.

**Held Orders.** For any order held, delayed or rescheduled at the request of the Buyer, Seller may, at its sole option, (1) require payment to be based on any reasonable basis, including but not limited to the contract price, and any additional expenses, or cost resulting from such a delay; (2) store Products at the sole cost and risk of loss of the Buyer; and/or (3) charge to the Buyer those prices under the applicable price policy. Payment for such price, expenses and costs, in any such event, shall be due by Buyer within thirty (30) days from date of Seller's invoice. Any order so held delayed or rescheduled beyond six (6) months will be treated as a Buyer termination.

**Drawing Approval.** Seller will design the Products in line with, in Seller's judgment, good commercial practice. If at drawing approval Buyer makes changes outside of the design as covered in their specifications, Seller will then be paid reasonable charges and allowed a commensurate delay in shipping date based on the changes made.

**Drawing Re-Submittal.** When Seller agrees to do so in its quotation, Seller shall provide Buyer with the first set of factory customer approval drawing(s) at Seller's expense. The customer approval drawing(s) will be delivered at the quoted delivery date. If Buyer requests drawing changes or additions after the initial factory customer approval drawing(s) have been submitted by Seller, the Seller, at its option, may assess Buyer drawing charges. Factory customer approval drawing changes required due to misinterpretation by Seller will be at Seller's expense. Approval drawings generated by Bid-Manager are excluded from this provision.

## **WARRANTY**

**Warranty for Products.** Seller warrants that the Products manufactured by it will conform to Seller's applicable specifications and be free from failure due to defects in workmanship and material for one (1) year from the date of installation of the Product or eighteen (18) months from the date of shipment of the Product, whichever occurs first.

In the event any Product fails to comply with the foregoing warranty Seller will, at its option, either (a) repair or replace the defective Product, or defective



part or component thereof, F.O.B. Seller's facility freight prepaid, or (b) credit Buyer for the purchase price of the Product. All warranty claims shall be made in writing.

Seller requires all non-conforming Products be returned at Seller's expense for evaluation unless specifically stated otherwise in writing by Seller. This warranty does not cover failure or damage due to storage, installation, operation or maintenance not in conformance with Seller's recommendations, including as set forth in these Terms and Conditions of Sale, and industry standard practice or due to accident, misuse, abuse, or negligence. This warranty does not cover breach of data or system security, including that of information technology infrastructure, computers, software, hardware, databases, electronic systems (including database management systems), and networks. This warranty does not cover reimbursement for labor, gaining access, removal, installation, temporary power or any other expenses, which may be incurred in connection with repair or replacement. This warranty does not apply to equipment not manufactured by Seller. Seller limits itself to extending the same warranty it receives from the third-party supplier, to the extent such third party permits assignment of its warranty.

**Extended Warranty for Products.** If requested by the Buyer and specifically accepted in writing by Seller, the foregoing standard warranty for Products will be extended from the date of shipment for the period and price indicated below:

- 24 months – 2% of Contract Price
- 30 months – 3% of Contract Price
- 36 months – 4% of Contract Price

**Special Warranty (In and Out) for Products.** If requested by the Buyer and specifically accepted in writing by Seller, Seller will, during the warranty period for Products, at an additional cost of 2% of the contract price, be responsible for the direct cost of:

1. Removing the Product from the installed location.
2. Transportation to the repair facility and return to the site.
3. Reinstallation on site.

The total liability of Seller for this Special Warranty for Products is limited to 50% of the contract price of the particular Product being repaired and excludes expenses for removing adjacent apparatus, walls, piping, structures, temporary service, etc.

**Warranty for Services.** Seller warrants that the Services performed by it hereunder will be performed in accordance with generally accepted professional standards. The Services, which do not so conform, shall be corrected by Seller upon notification in writing by the Buyer within one (1) year after completion of the Services. Unless otherwise agreed to in writing by Seller, Seller assumes no responsibility with respect to the suitability of the Buyer's, or its customer's, equipment or with respect to any latent defects in equipment not supplied by Seller. This warranty does not cover damage to Buyer's, or its customer's, equipment, components or parts resulting in whole, or in part from improper maintenance or operation (including failure to comply with Seller's recommendations) or from their deteriorated condition. Buyer will, at its cost, provide Seller with unobstructed access to the defective Services, as well as adequate free working space in the immediate vicinity of the defective Services and such facilities and systems, including, without limitation, docks, cranes and utility disconnects and connects, as may be necessary in order that Seller may perform its warranty obligations. The conducting of any tests shall be mutually agreed upon and Seller shall be notified of, and may be present at, all tests that may be made.

**Warranty for Power Systems Studies.** Seller warrants that any power systems studies performed by it will conform to generally accepted professional standards. Any portion of the study, which does not so conform, shall be corrected by Seller upon notification in writing by the Buyer within six (6) months after completion of the study. All warranty work shall be performed in a single shift straight time basis Monday through Friday. In the event that the study requires correction of warranty items on an overtime schedule, the premium portion of such overtime shall be for the Buyer's account.

**Limitation on Warranties for Products, Services and Power Systems Studies.** THE FOREGOING WARRANTIES ARE EXCLUSIVE EXCEPT FOR WARRANTY OF TITLE. SELLER DISCLAIMS ALL OTHER WARRANTIES INCLUDING ANY IMPLIED WARRANTIES OF MERCHANTABILITY AND FITNESS FOR A PARTICULAR PURPOSE. CORRECTION OF NON-CONFORMITIES IN THE MANNER AND FOR THE PERIOD OF TIME PROVIDED ABOVE SHALL CONSTITUTE SELLER'S SOLE LIABILITY AND BUYER'S EXCLUSIVE REMEDY FOR FAILURE OF SELLER TO MEET ITS WARRANTY OBLIGATIONS, WHETHER CLAIMS OF THE BUYER ARE BASED IN CONTRACT, IN TORT (INCLUDING NEGLIGENCE OR STRICT LIABILITY) OR OTHERWISE.

**Asbestos.** Federal Law requires that building or facility owners identify the presence, location and quantity of asbestos containing material (hereinafter "ACM") at work sites. Seller is not licensed to abate ACM. Accordingly, for any contract which includes the provision of Services, prior to (i) commencement of work at any site under a specific Purchase Order, (ii) a change in the work scope of any Purchase Order, the Buyer will certify that the work area associated with the Seller's scope of work includes the handling of Class II ACM, including but not limited to generator wedges and high temperature gaskets which include asbestos materials. The Buyer shall, at its expense, conduct abatement should the removal, handling, modification or reinstallation, or some or all of them, of said Class II ACM be likely to generate airborne asbestos fibers; and should such abatement affect the cost of or time of performance of the work then Seller shall be entitled to an equitable adjustment in the schedule, price and other pertinent affected provisions of the contract.

**Compliance with Nuclear Regulation.** Seller's Products are sold as commercial grade Products not intended for application in facilities or activities licensed by the United States Nuclear Regulatory Commission for atomic purposes. Further certification will be required for use of the Products in any safety-related application in any nuclear facility licensed by the U.S. Nuclear Regulatory Commission.

**Returning Products.** Authorization and shipping instructions for the return of any Products must be obtained from Seller before returning the Products. When return is occasioned due to Seller error, full credit including all transportation charges will be allowed.

**Product Notices.** Buyer shall provide the users, including its employees, and in the case of permitted resale, any subsequent purchasers of the Products with all Seller supplied Product notices, warnings, instructions, recommendations and similar materials.

**Cybersecurity.** Seller is not responsible for a breach of data or electronic system security, including, but not limited to, a system intrusion or interference, virus or malicious code attack, loss of data, data theft, unauthorized access to confidential information and/or nonpublic personal information, hacking incident or any acts of data ransom, caused by any third-party equipment, modification made to a Product other than by Seller, or

failure by Buyer to comply with Eaton Assemblies Cybersecurity Hardening Guidelines at [www.eaton.com/assemblies-security](http://www.eaton.com/assemblies-security) (the "Cybersecurity Guidelines"). Seller may revise the Cybersecurity Guidelines at any time without prior notice.

Buyer is responsible for obtaining (at Buyer's expense) assurances from third party suppliers with respect to cybersecurity for third party equipment. As a condition of use and/or resale, Buyer shall direct all users of the Products purchased to access the applicable accompanying Eaton End User License Agreement (EULA) and the Cybersecurity Guidelines, all of which are subject to change in terms and practices, at Seller's discretion, at any time.

**Force Majeure.** Seller shall not be liable for failure to perform or delay in performance due to fire, flood, strike or other labor difficulty, act of God, act of any governmental authority or of the Buyer, riot, embargo, fuel or energy shortage, car shortage, wrecks or delays in transportation, or due to any other cause beyond Seller's reasonable control. In the event of delay in performance due to any such cause, the date of delivery or time for completion will be extended by a period of time reasonably necessary to overcome the effect of such delay. Seller cannot be held liable, and Buyer shall not be entitled to any damages and/or indemnifications, in case Seller is prevented, hindered or delayed from or in performing any of its obligations resulting from the impact of the outbreak of COVID-19 or any future pandemic or epidemic for reasons not attributable to Seller.

**Liquidated Damages.** Contracts which include liquidated damage clauses for failure to meet shipping or job completion promises are not acceptable or binding on Seller, unless such clauses are specifically accepted in writing by an authorized representative of the Seller at its headquarters office.

**Patent Infringement.** Seller will defend or, at its option, settle any suit or proceeding brought against Buyer, or Buyer's customers, to the extent it is based upon a claim that any Product or part thereof, manufactured by Seller or its subsidiaries and furnished hereunder, infringes any United States patent, other than a claim of infringement based upon use of a Product or part thereof in a process, provided Seller is notified in reasonable time and given authority, information and assistance (at Seller's expense) for the defense of same. Seller shall pay all legal and court costs and expenses and court-assessed damages awarded therein against Buyer resulting from or incident to such suit or proceeding. In addition to the foregoing, if at any time Seller determines there is a substantial question of infringement of any United States patent, and the use of such Product is or may be enjoined, Seller may, at its option and expense: either (a) procure for Buyer the right to continue using and selling the Product; (b) replace the Product with non-infringing apparatus; (c) modify the Product so it becomes non-infringing; or (d) as a last resort, remove the Product and refund the purchase price, equitably adjusted for use and obsolescence.

In no case does Seller agree to pay any recovery based upon its Buyer's savings or profit through use of Seller's Products whether the use be special or ordinary. The foregoing states the entire liability of Seller for patent infringement.

The preceding paragraph does not apply to any claim of infringement based upon: (a) any modification made to a Product other than by Seller; (b) any design and/or specifications of Buyer to which a Product was manufactured; or (c) the use or combination of Product with other products where the Product does not itself infringe. As to the above-identified claim situations where the preceding paragraph does not apply, Buyer shall defend and hold Seller harmless in the same manner and to the extent as Seller's obligations described in the preceding paragraph. Buyer shall be responsible for obtaining (at Buyer's expense) all license rights required for Seller to be able to use software products in the possession of Buyer where such use is required in order to perform any Service for Buyer.

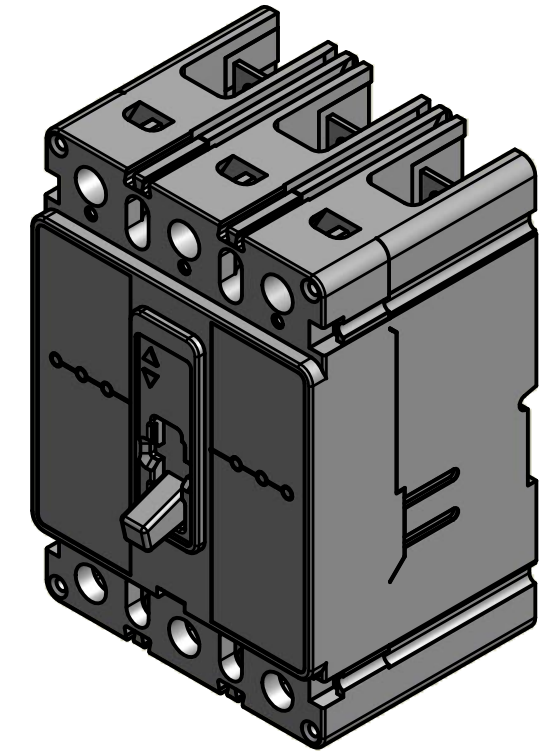
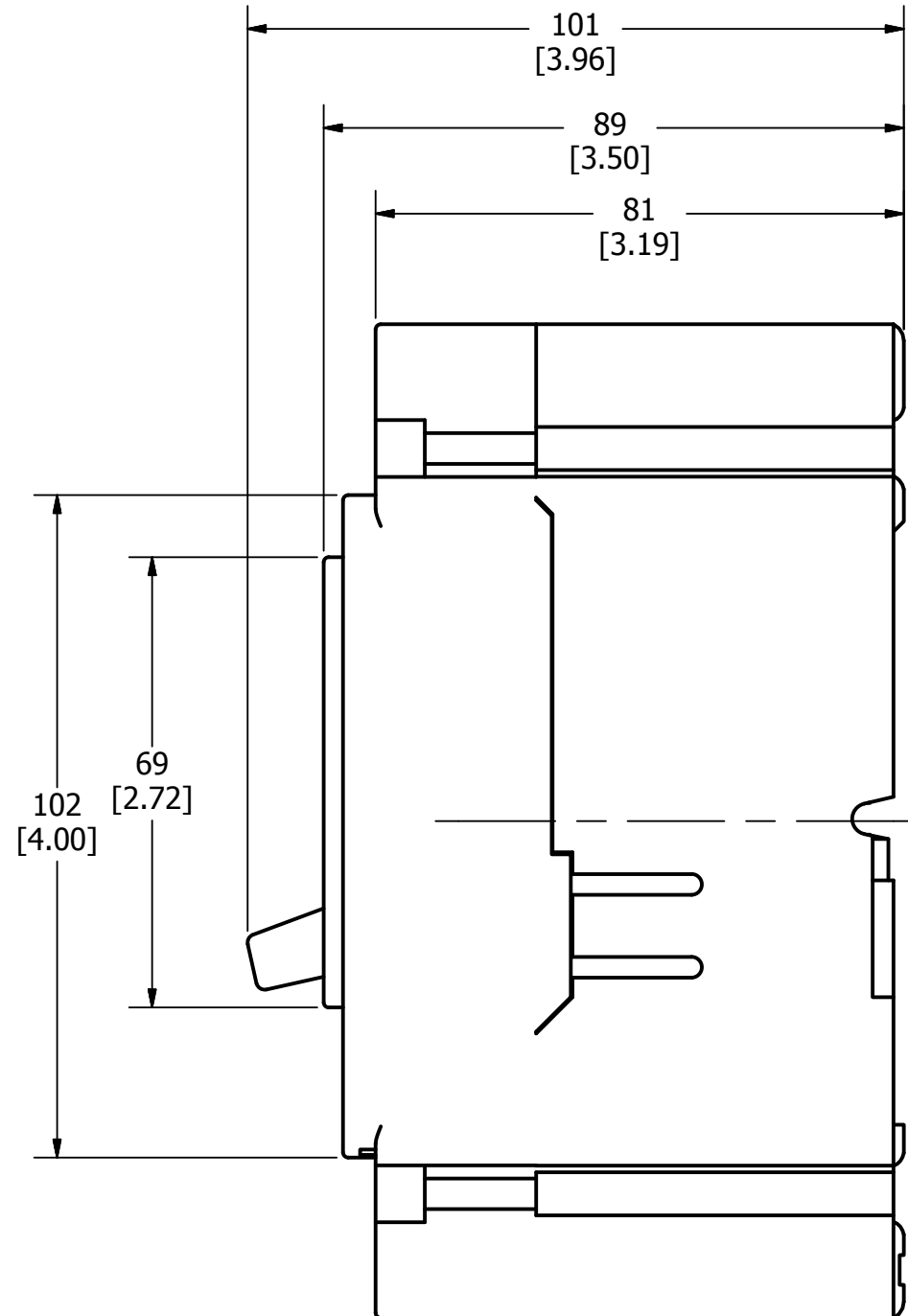
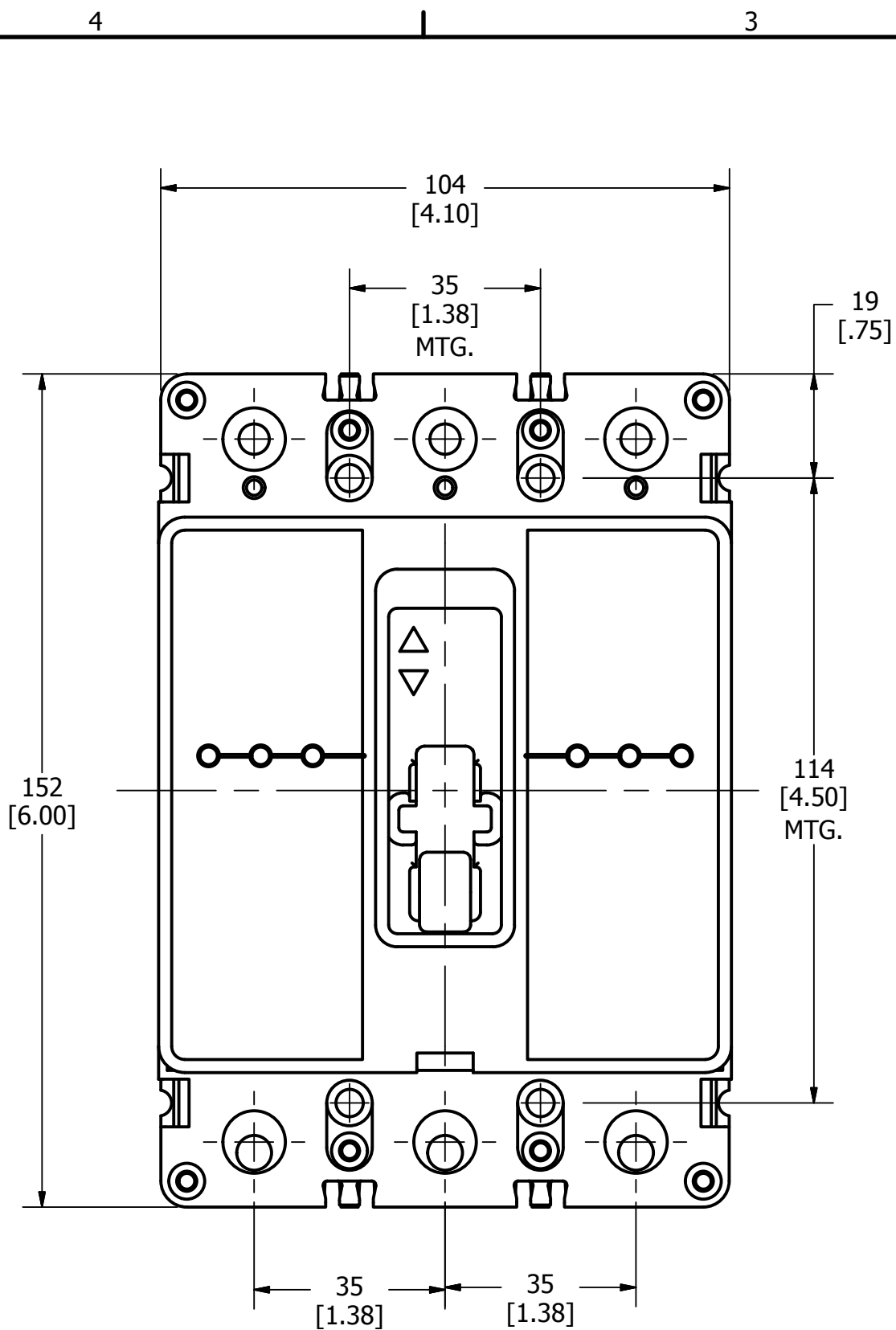
With respect to a Product or part thereof not manufactured by Seller or its subsidiaries, Seller will attempt to obtain for Buyer, from the supplier(s), the patent indemnification protection normally provided by the supplier(s) to customers.

**Compliance with OSHA.** Seller offers no warranty and makes no representation that its Products comply with the provisions or standards of the Occupational Safety and Health Act of 1970, or any regulation issued thereunder. In no event shall Seller be liable for any loss, damage, fines, penalty or expenses arising under said Act.

**Limitation of Liability.** THE REMEDIES OF THE BUYER SET FORTH IN THIS CONTRACT ARE EXCLUSIVE AND ARE ITS SOLE REMEDIES FOR ANY FAILURE OF SELLER TO COMPLY WITH ITS OBLIGATIONS HEREUNDER. NOTWITHSTANDING ANY PROVISION IN THIS CONTRACT TO THE CONTRARY, IN NO EVENT SHALL SELLER BE LIABLE IN CONTRACT, IN TORT (INCLUDING NEGLIGENCE OR STRICT LIABILITY) OR OTHERWISE FOR DAMAGE TO PROPERTY OR EQUIPMENT OTHER THAN PRODUCTS SOLD UNDER THIS AGREEMENT, LOSS OF PROFITS OR REVENUE, LOSS OF USE OF PRODUCTS, LOST PRODUCTION, COST OF CAPITAL, LOSS OF, DAMAGE TO, OR UNAUTHORIZED ACCESS TO DATA, BREACH OF SYSTEM SECURITY, FAILURE TO TRANSMIT OR RECEIVE DATA, BUSINESS INTERRUPTION, CLAIMS OF CUSTOMERS OF THE BUYER OR ANY SPECIAL, INDIRECT, INCIDENTAL OR CONSEQUENTIAL DAMAGES WHATSOEVER, REGARDLESS OF WHETHER SUCH POTENTIAL DAMAGES ARE FORESEEABLE OR IF SELLER HAS BEEN ADVISED OF THE POSSIBILITY OF SUCH DAMAGES. THE TOTAL CUMULATIVE LIABILITY OF SELLER ARISING FROM OR RELATED TO THIS CONTRACT WHETHER THE CLAIMS ARE BASED IN CONTRACT, IN TORT (INCLUDING NEGLIGENCE OR STRICT LIABILITY) OR OTHERWISE, SHALL NOT EXCEED THE PRICE OF THE PRODUCT OR SERVICES ON WHICH SUCH LIABILITY IS BASED.

**Distributors and Third-Party Agents.** In order to ensure that distributors and third party agents acting on behalf of Seller share Seller's commitment to doing business right, all distributors and agents shall abide by Seller's [Anticorruption Policy](#).

Eaton Corporation.  
1000 Cherrington Parkway Moon Township, PA 15108 United States  
Tel: 1-800-525-2000  
Eaton.com



TITLE TYPE HFD THERMAL MAGNETIC CIRCUIT BREAKERS THREE POLE, SERIES C		DRAFTER/DESIGNER DM/JS	DATE (YYYY/MM/DD) 2014/08/21
EATON CORPORATION - CONFIDENTIAL AND PROPRIETARY NOTICE TO PERSONS RECEIVING THIS DOCUMENT AND/OR TECHNICAL INFORMATION THIS DOCUMENT, INCLUDING THE DRAWING AND INFORMATION CONTAINED THEREON, IS CONFIDENTIAL AND IS THE EXCLUSIVE PROPERTY OF EATON CORPORATION, AND IS MERELY ON LOAN AND SUBJECT TO RECALL BY EATON AT ANY TIME. BY TAKING POSSESSION OF THIS DOCUMENT, THE RECIPIENT ACKNOWLEDGES AND AGREES THAT THIS DOCUMENT MAY NOT BE USED IN ANY MANNER ADVERSE TO THE INTERESTS OF EATON AND THAT NO PORTION OF THIS DOCUMENT MAY BE COPIED OR OTHERWISE REPRODUCED WITHOUT THE PRIOR WRITTEN CONSENT OF EATON. IN THE CASE OF CONFLICTING CONTRACTUAL PROVISIONS, THIS NOTICE SHALL GOVERN THE STATUS OF THIS DOCUMENT. ©2014 Eaton Corporation, All Rights Reserved		SIZE B	DRAWING NUMBER <b>HFD3_</b>
		UNLESS OTHERWISE SPECIFIED DIMENSIONS IN MILLIMETERS [INCHES]	REVISION <b>003</b>
		SCALE N/A	SHEET 1 OF 1

THIS PAGE LEFT BLANK

# Eaton TMRD1UN

Catalog Number: TMRD1UN

Eaton Plug in solid state timing relay



## General specifications

Product Name	Eaton timing relay	Catalog Number	TMRD1UN
UPC	786685215402	Product Length/Depth	4 in
Product Height	1.15 in	Product Width	0.3 in
Product Weight	0.2 lb	Compliances	RoHS Compliant CE Marked

## Certifications

cRUus  
UL Listed (when used with Eaton socket)

## Product specifications

### Contact configuration

SPDT

### Type

Plug-in Solid State

### Contact Rating

10A

### Current rating - max

10 A

### Frequency rating

50/60 Hz

### Mounting method

DIN rail

### Current rating - min

6 A

### Amperage Rating

10A

## Resources

### Catalogs

Eaton's Volume 7—Logic Control, Operator Interface and Connectivity Solutions

### Specifications and datasheets

Eaton Specification Sheet - TMRD1UN



Eaton Corporation plc  
Eaton House  
30 Pembroke Road  
Dublin 4, Ireland  
Eaton.com  
© 2023 Eaton. All Rights Reserved.

Eaton is a registered trademark.

All other trademarks are property of their respective owners.



Eaton.com/socialmedia



**TMRD1UN**

(EN) Multifunction time relay

2459-02-001 Rev.: 0

- universal supply voltage AC/DC 12 - 240 V
- for electric appliances, controlling of the illumination, heating, motors, ventilators ...
- using for warning illumination on the road, flashers, cyclers, frequently switched systems ...
- 10 functions:
  - 5 time functions controlled via supply voltage
  - 4 time functions controlled via control input
  - 1 function of memory (latching) relay
- Time scale 0.1 s - 10 days divided into 10 ranges
- Output contact: SPDT or DPDT 16 A
- Output indication: multifunction red LED, flashing at certain states
- 1-MODULE, DIN rail mounted

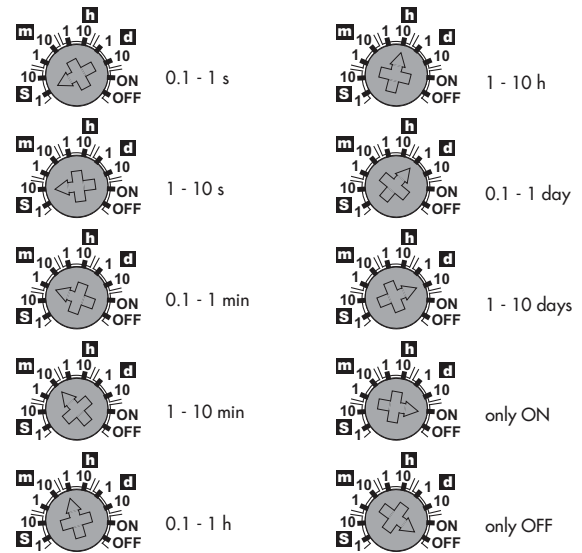
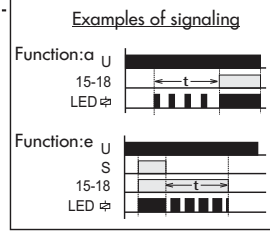
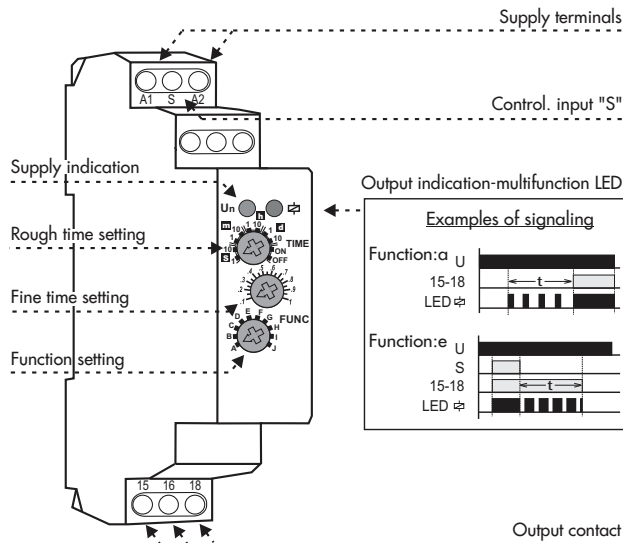


This device is designed for connection of 1-phase main 12-240 V AC/DC and must be installed according to norms valid in existing state. Connections to this device must be made according to the details in this instruction sheet. Installation, connection, setting and servicing should be installed by qualified electrician staff only, who understands this instruction sheet and functions of respective device.

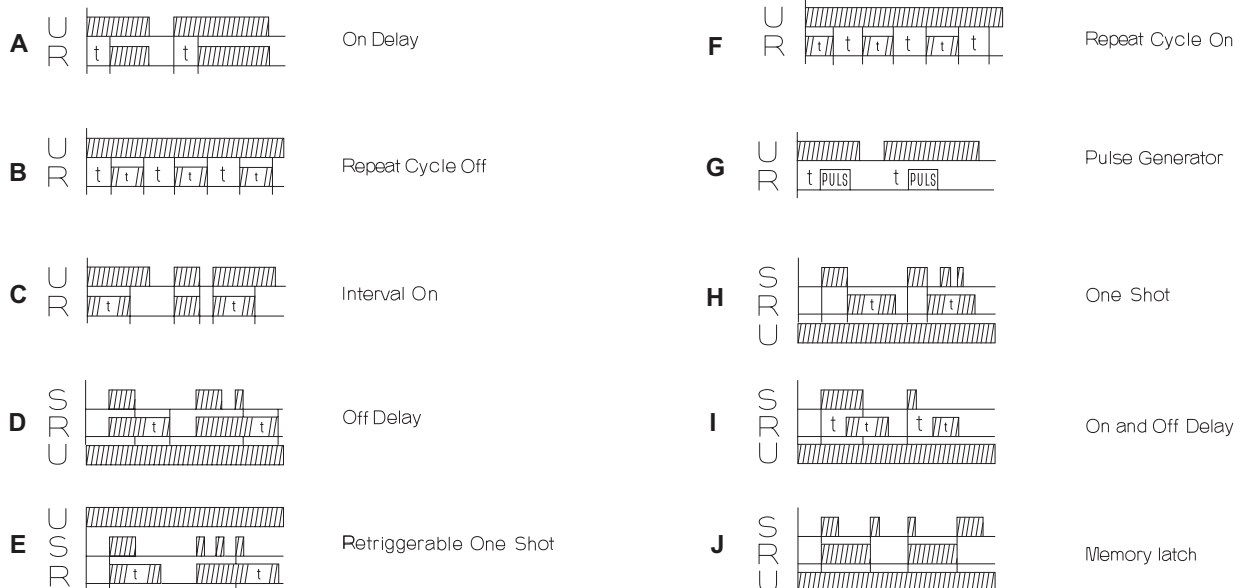
Before starting installation ensure that the main switch is in "SWITCH OFF" position and there should be no power going to the device. Qualified installer must also ensure the device is being installed into a temperature controlled environment which will guarantee not to exceed the specified maximal operating temperature. For installation and setting use a screw-driver with 2 mm tip.

Description

Time ranges



Functions



## Technical parameters

	<b>SPDT or DPDT</b>
Number of functions:	10
Supply:	A1 - A2
Supply voltage:	AC/DC 12 - 240 V (AC 50-60 Hz)
Consumption:	AC 0.7 - 3 VA / DC 0.5 - 1.7 W
Supply indication:	green LED
Time ranges:	0.1 s - 10 days
Time setting:	rotary switch
Time deviation:	5 % - mechanical setting
Repeat accuracy:	0.2 % - set value stability
Temperature coefficient:	0.01 % / °C, at = 20 °C
<b>Output</b>	
Changeover contacts:	1, AgNi or 2, AgNi
Rated current:	16 A / AC1
Breaking capacity:	4000 VA / AC1, 384 W / DC
Inrush current:	30 A / <3 s
Switching voltage:	250 V AC1 / 24 V DC
Min. breaking capacity DC:	500 mW
Switch drop:	Y
Load-B1 terminal connection:	Y
Output indication:	multifunction red LED
Mechanical life:	3x10 <sup>7</sup>
Electrical life:	0.7x10 <sup>5</sup>
Reset time:	max. 150 ms
Operating temperature:	-20 .. +55 °C
Storage temperature:	-30 .. +70 °C
Electrical strength:	4 kV (supply - output)
Operating position:	any
Mounting/DIN rail:	DIN rail EN 60715
Protection degree:	IP 40
Overvoltage category:	III.
Pollution degree:	2
Max. cable size:	2.5 mm <sup>2</sup> / with cavern 1.5 mm <sup>2</sup>
Dimensions:	90 x 17.6 x 64 mm
Weight:	69 g
Standards:	EN 61812-1, EN 61010-1
Controlling	at supply: AC/DC 12 - 240 V
Control. voltage:	AC/DC 12 - 240 V
Consumption of input:	AC 0.025 - 0.2 VA / DC 0.1 - 0.7 W
Load between S-A2:	U
Glow-tubes:	Y
Control. terminals:	A1-S
Impulse length:	min. 25 ms / max. unlimited

The device is constructed for 1-phase main and must be installed in accordance with regulations and standards applicable in the country of use. While installing the device follow the instructions in this manual and on the cover packaging of the device. Do not operate the device out of the specified range of technical parameters. Installation and launching can be done only by a person with an adequate electro-technical qualification who is accredited for this work and is informed about this manual and functions of this device. The person who executes the installation is responsible for correct and safe installation of this device. Keep in mind that it is a fully electronic device when mounting. Non problematic function of the device also depends on the previous way of transportation, storing and handling. If you find any sign of damage, deformation, malfunction or a missing part, do not install this device and claim it at its seller. After the expiry date of the product it is possible to demount, recycle, and store it at protected dumping site.

### 1) Protection of the device

- the device contains protections against over-voltage peaks, and disturbing pulses in the main. To ensure correct function of these protective elements, suitable protections of higher degree (A,B,C) must be mounted into the installation, and screening of switched devices (contactors, motors, inductive loads etc.) must be applied.
- it is convenient to ensure protection of the device by adequate elements of over-current and over-voltage protection fuses, surge voltage protector

### 2) Operating conditions

- while installing this device it is necessary to consider temperature rate of ambient devices so the operation temperature stated in technical parameters is kept. It is necessary to ensure air circulation so the operation temperature is not exceeded in any case.
- to ensure the stated operating life and correct function of the device, it is not recommended to expose these to extreme influences that can negatively effect correct function of the device permanent exposure to temperatures (see technical parameters), aggressive evaporations, chemicals, high relative humidity above 95%, strong electromagnetic field of microwave radiation etc.
- it is necessary to avoid placing devices close to sources of electromagnetic disturbances to ensure their correct function

- all our products are in compliance with requirements of EMC (electromagnetic immunity and resistance) and in accordance with governmental regulation. However it is necessary to pay attention while connecting products to the circuit with appliances that create electromagnetic disturbances (conductors, motors), or power cables close to them. It is recommended to have the connection cables of a product (supply and operating inputs) as short as possible and have them led separately into power conductors. In case of connecting product into a circuit with conductors or motors, it is necessary to protect the product by adequate external protective elements RC elements, varistors or surge voltage protectors

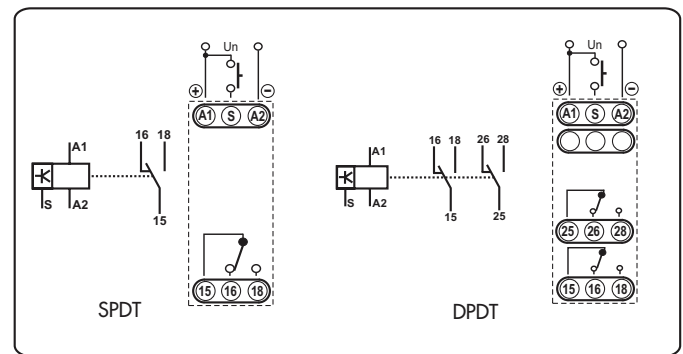
### 3) Handling the device and its use

- use a screwdriver with an approximate width 2mm for installation and setting
- do not use brute force to screw input terminals (maximally 0,5N/m), do not put exceeded pressure on to the holding parts of terminals so the inner construction of the device is not damaged.
- protect the device against falls and excessive vibrations
- do not overload relay output contacts, mainly while using loads of another category than AC-1
- if contacts of relay melted while switching big loads, it is necessary to use an inserted contactor or power relay rated for required load in the current installation.

### Description of protective elements in devices

All timers and monitoring relays in our assortment are equipped by protective elements against possible over-voltage in the main. The nominal voltage of the applied varistors is 275V. During short-time over-voltage peaks, the varistor lowers its leakage resistance and accumulates the grown over-voltage peaks. In case this over-voltage has a character of short-time peak, varistor is able to react repeatedly this way and thus non-destructively protect a device against these negative influences. Other protective elements that are used in devices are transils a zener diodes, that eliminate over-voltage pulses, and are installed in supply and input circuits of the device (for example when switching inductive loads). In case of switching loads of inductive character it is recommended to separate supply of output elements (motors, contactors, etc.) from supply of monitoring and controlling inputs of

## Connection



RELAY CONTACT 16 A	LOAD								
						AC1	AC3	AC15	DC1 (24/110/220 V)
AgNi	1000 W					4000 VA	0.9 kW	750 VA	16 A/0.5 A/0.35 A



# Eaton 10250T1323

Catalog Number: 10250T1323

Eaton 10250T pushbutton, Heavy-duty selector switch operator, 10250T, 30.5 mm, Cam 3, 60° throw, NEMA 3, 3R, 4, 4X, 12, 13, Non-illuminated, Three-position, Knob, Black actuator



## General specifications

<b>Product Name</b>	<b>Catalog Number</b>
Eaton 10250T pushbutton	10250T1323
<b>UPC</b>	<b>Product Length/Depth</b>
782113226330	1.9 in
<b>Product Height</b>	<b>Product Width</b>
2 in	1.9 in
<b>Product Weight</b>	<b>Warranty</b>
0.25 lb	1 year
<b>Compliances</b>	<b>Certifications</b>
CE Marked	CSA Certified UL Listed

## Product specifications

### Product Category

Selector switch

### Throw type

60 °

### Series

10250T

### Number of positions

3

### Type

30.5 mm, Heavy-Duty

### Actuator color

Black

### NEMA rating

NEMA 3, NEMA 3R, NEMA 4, NEMA 4X, NEMA 12, NEMA 13

### Rating

NEMA 3, NEMA 3R, NEMA 4, NEMA 4X, NEMA 12, NEMA 13

### Illumination

Non-illuminated

### Cam code

Cam 3

### Actuator

Knob

## Resources

### Catalogs

[Eaton's Volume 7—Logic Control, Operator Interface and Connectivity Solutions](#)

### Multimedia

[How to size and select a Power Supply](#)

### Specifications and datasheets

[Eaton Specification Sheet - 10250T1323](#)



Eaton Corporation plc  
Eaton House  
30 Pembroke Road  
Dublin 4, Ireland  
Eaton.com

© 2023 Eaton. All Rights Reserved.

Eaton is a registered trademark.

All other trademarks are property of their respective owners.



[Eaton.com/socialmedia](https://www.eaton.com/socialmedia)

### 30.5 mm Heavy-Duty Watertight/Oiltight—10250T



### Contents

<i>Description</i>	<i>Page</i>
30.5 mm Heavy-Duty Watertight/Oiltight—10250T	
Product Overview . . . . .	V7-T1-214
Product Identification . . . . .	V7-T1-214
Catalog Number Selection . . . . .	V7-T1-215
Product Selection	
Point-of-Purchase Packaging . . . . .	V7-T1-217
Non-Illuminated Momentary Pushbutton Units . . . . .	V7-T1-218
Pushbuttons . . . . .	V7-T1-219
Illuminated Momentary Pushbutton Units . . . . .	V7-T1-222
Indicating Light Units . . . . .	V7-T1-223
Illuminated Pushbuttons and Indicating Lights . . . . .	V7-T1-224
Push-Pull Emergency Stop . . . . .	V7-T1-226
Illuminated Push-Pull Units . . . . .	V7-T1-229
Potentiometers . . . . .	V7-T1-232
Push-Pull Operators . . . . .	V7-T1-233
Selector Switch Units . . . . .	V7-T1-237
Selector Switch Selection . . . . .	V7-T1-238
Selector Switch Operators . . . . .	V7-T1-241
Illuminated Selector Switch Operators . . . . .	V7-T1-244
Joystick Units . . . . .	V7-T1-245
Joysticks . . . . .	V7-T1-246
Roto-Push Units . . . . .	V7-T1-249
Roto-Push Operators . . . . .	V7-T1-250
Accessories . . . . .	V7-T1-255
Options . . . . .	V7-T1-260
Replacement Parts . . . . .	V7-T1-269
Technical Data and Specifications . . . . .	V7-T1-271
Dimensions . . . . .	V7-T1-274



### Application Description

#### Contact Operation

Slow make and break. All normally closed contacts have positive opening operation, i.e., normally closed contacts are forced open in the event of contact weld or spring breakage.

### Standards and Certifications

- CE EN 60947-5-1 and 60947-5-5
- UL 508—File No. 131568
- CSA C22.2 No. 14—File No. LR68551



### Ingress Protection

When mounted in similarly rated enclosure—

- Standard indicating lights
  - UL (NEMA) Type 1, 2, 3, 3R, 3S, 4, 4X, 12, 13
  - IEC IP65
- Most other operators
  - UL (NEMA) Type 1, 2, 3, 3R, 4, 4X, 12, 13
  - IEC IP65

### Product Description

The 30.5 mm pushbutton line features a zinc die cast construction with chrome-plated housing and mounting nut. The same durable construction is also available with the corrosive resistant E34 line of pushbuttons. See E34 section on **Pages V7-T1-284 to V7-T1-325**.

### Features

- Heavy-duty zinc die cast construction
- Enclosed silver contacts with reliability nibs
- Diaphragm seals with drainage holes
- Grounding nibs on the operator casing

### Benefits

- Reliability nibs improve contact reliability even under dry circuit and fine dust conditions
- Drainage holes prevent buildup of liquid inside the operator which can prevent operation in freezing environments
- Grounding nibs bit through paint and other coatings to provide secure ground

#### 1

### Product Overview

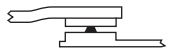
#### Reliability Nibs

Eaton's contact blocks feature enclosed silver contacts with pointed "reliability nibs" for reliable performance from logic level up to 600V. To ensure reliable switching, nibs bite through oxide which can form on silver contacts, eliminating the need for expensive logic level blocks for most applications.

#### Reliability Nibs



Dry Circuit



Medium Duty



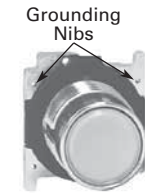
Heavy-Duty

Reliability nibs improve performance in dry circuit, corrosive, fine dust and other contaminated atmospheres. Under normal environmental conditions, the minimum operational voltage is 5V and the minimum operational current is 1 mA, AC/DC. For operation under a wider range of environmental conditions, logic level contact blocks with inert palladium tipped contacts are recommended.

#### Grounding Nibs

10250T line operators have "grounding nibs"—four metal points on the operator casting designed to bite through most paints and other coatings on metal panels to enhance the ground connection when the operator is securely tightened.

#### Grounding Nibs

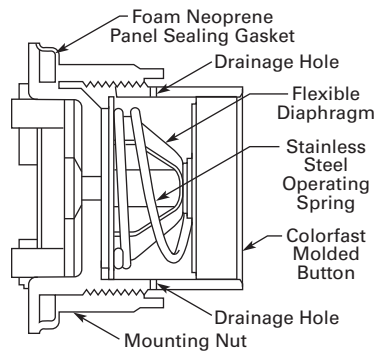


#### Diaphragm Seal with Drainage Holes

##### Liquid Drainage

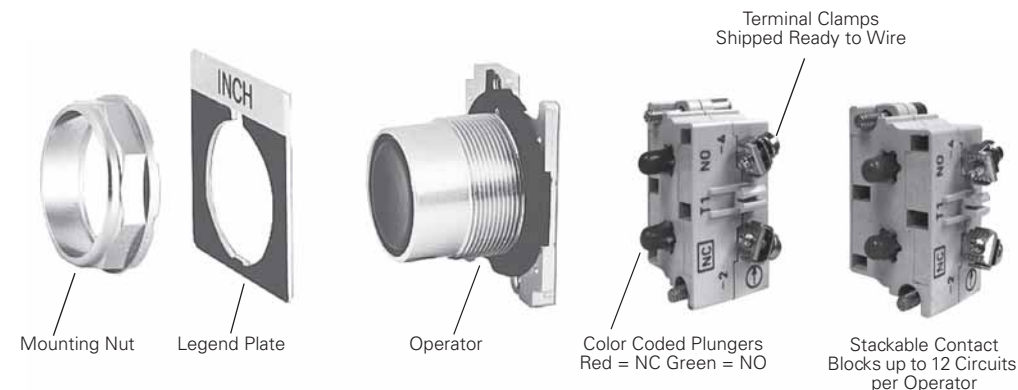
Eaton's pushbutton operators offer front of panel drainage via holes in the operator bushing. Hidden from view by the mounting nut, these holes prevent buildup of liquid inside the operator, which can prevent operation in freezing environments. The holes also provide a route for escaping liquid in high pressure washdowns, effectively relieving pressure from the internal diaphragm seal, ensuring reliable sealing in applications even beyond NEMA 4.

#### Diaphragm Seal



### Product Identification

#### 30.5 mm Heavy-Duty Watertight/Oiltight—10250T Series



#### 1

### Selector Switch Selection



#### Cam and Contact Block Selection

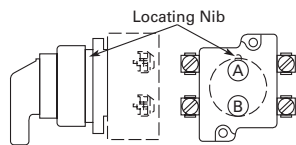
Selector switches in their varied forms (two-position, three-position and four-position) are a big factor contributing to the great flexibility of control that a well rounded line of “pushbuttons” can achieve. Because of their flexibility, they tend to cause difficulty with product selection and application. The following systematic approach should simplify that task.

Cam and contact block selection is better understood if you:

- Work with each incoming and outgoing wire/circuit separately.
- Recognize the terms NO and NC only identify the type of contact by its mode before mounting to the operator. The “X-O” table (Page V7-T1-240) shows how that contact will act after assembly to the operator with the selected cam shape. X = closed circuit, O = open circuit.

- Up to six NO or NC contacts may be mounted behind each plunger location for a total of twelve contacts. Single circuit contact blocks have only one plunger with the other side of the block “open.” Therefore, single circuit contact blocks transmit motion to blocks behind them only for the position containing the circuit.
- Each cam has two separate lobes, each of which operates one of the two contact block plungers independently of each other. Those are identified as position A (locating nib side) and position B (opposite of locating nib). The position designations give direction in selecting and mounting of the contact blocks.

#### Contact Circuit Locations

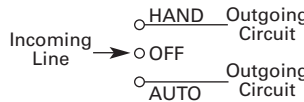


#### Systematic Approach

Application: **HAND-OFF-AUTO** selector switch. In this circuit, one incoming line is distributed to two other outgoing circuits by the switch. The two circuits can be looked at individually.

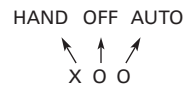
#### Step 1: Elementary Diagram.

Construct on paper, or in your mind, a simple elementary diagram of the switching scheme as follows:



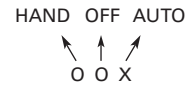
#### Step 2: “X-O” Pattern.

From the elementary diagram, you can construct an “X-O” diagram which describes when the contacts are to be closed (X) or open (O) in the various positions of the switch. The “X-O” for the **HAND** circuit looks like this:



In this circuit, you want a contact closed on the left (HAND) but open in the center and right.

For the **AUTO** circuit, the “X-O” diagram would look like this:



Putting them together, the complete “X-O” diagram is:



Once the “X-O” diagram has been generated the next step is to select the cam and contact block, or blocks, needed to perform the desired “X-O” functions. The selection tables on the following pages list the various types (shapes) of cams by number to choose from and the type of contact and position to achieve the function outlined in your “X-O” diagram.

### Step 3: Cam Selection.

The cam you select determines the operation of all contact blocks mounted to the operator. It is selected on the basis that it provides the simplest circuitry for the desired “X-O” diagram. The selection tables show all the “X-O” combinations. For the purpose of this example, the applicable portion of those tables is shown on this page.

Now to make the cam selection, make a simple worksheet such as:

	Cam 2	Cam 3
X O O	(A)NO-(B)NC	(A)NO
O O X	(B)NO	(B)NO

It becomes immediately obvious that cam 3 is the better choice for two reasons, (1) the series combination can be avoided making it simpler to wire, (2) only two contacts are required, which is less expensive than the three contacts required by cam 2.

### Step 4: Contact Block Selection.

Having selected the cam, contact block selection is simply a matter of gathering the A position and B position circuits into pairs which make up the most convenient contact block arrangement. If there is an imbalance in the number of circuits under A or B, then single circuit blocks must be selected for these leftover circuits.

Back to the worksheet, having selected cam 3 do this:



### Step 5: Selector Switch Operator.

Lastly, you have to choose from the many types of operators—knob and lever in various colors or keyed. Also what combinations of maintained and spring return functions are required. Selection of these operators can be found on **Page V7-T1-242**. For the example in step 4 you may want a three-position maintained black knob, cam 3—Catalog Number 10250T1323.

**The Complete Switch:** 10250T1323 with one 10250T2 or, for one composite catalog number, 10250T21KB found on **Page V7-T1-237**.

### Diagrams

Circuits shown illustrate connections to obtain a selector switch circuit combination and are shown with their appropriate line diagrams. Field wiring of jumper connections required as shown.

X = Closed circuit  
O = Open circuit

### Wiring of Jumper Connections



Four-position selector switches are limited to four contact blocks.

### Contact Blocks

For selection and number of available contact blocks per operator, see **Pages V7-T1-265 to V7-T1-268**.

### Example Selection Table

No.	"X-O" Pattern	Cam Code #2		Cam Code #3	
		Top A	Bottom B	Top A	Bottom B
1	X 0 0				—
4	0 0 X	—		—	

### Two-Position Selector Switch Contact Block Selection

No.	Desired Circuit and Operator Position		Contact Blocks Required to Accomplish Circuit Function	
			Top Plunger A	Bottom Plunger B
1	X	0		or
2	0	X		or

**Note**  
① Wired in series.

#### 1 Three-Position Switch—Cam and Contact Block Selection

No.	Desired Circuit and Operator Position			Operator with Cam Code #2		Operator with Cam Code #3	
				Mounting Location		Mounting Location	
	X	0	0	Top Plunger A	Bottom Plunger B	Top Plunger A	Bottom Plunger B
1	X	0	0				
2	X	X	0				
3	X	0	X				
4	0	0	X				
5	0	X	X				
6	0	X	0				



#### Four-Position Switch—Contact Block Selection

No.	Desired Circuit and Operator Position				Contact Blocks Required to Accomplish Circuit Function		No.	Desired Circuit and Operator Position				Contact Blocks Required to Accomplish Circuit Function	
					Mounting Location			Mounting Location		Mounting Location			
	X	0	0	0	Top Plunger A	Bottom Plunger B		Top Plunger A	Bottom Plunger B	Top Plunger A	Bottom Plunger B		
1	X	0	0	0			10	X	0	X	0		
2	0	X	0	0									
3	0	0	X	0			11	X	X	X	0		
4	0	0	0	X									
5	X	0	0	X			12	0	X	X	X		
6	0	X	X	0									
7	0	0	X	X			13	X	0	X	X		
8	X	X	0	0									
9	0	X	0	X			14	X	X	0	X		

#### Selector Switch Operators with Caps

UL (NEMA) Type 3, 3R, 4, 4X, 12, 13

#### Selector Switch Operators with Caps

	Positions	Operator Action <sup>②</sup>	Black Knob Selector Switch— Vertical Mounting <sup>③</sup>		Black Lever Selector Switch— Vertical Mounting <sup>③</sup>	
			Cam Code <sup>④</sup>	Catalog Number	Cam Code <sup>④</sup>	Catalog Number
<b>Two-Position Maintained</b> <sup>①</sup> 	Two-position—60° throw		1	10250T1311	1	10250T3011
			1	10250T1371	1	10250T3071
<b>Three-Position Maintained</b> <sup>⑤</sup> 	Three-position—60° throw		2	10250T1322	2	10250T3022
			3	10250T1323	3	10250T3023
			2	10250T1332	2	10250T3032
			3	10250T1333	3	10250T3033
			2	10250T1342	2	10250T3042
			3	10250T1343	3	10250T3043
			2	10250T1352	2	10250T3052
			3	10250T1353	3	10250T3053
	Four-position—40° throw		7	10250T1367	7	10250T3067

#### Notes

- ① Black knob selector switch, cam 1 shown.
- ② M = Maintained. S = Spring return in direction of arrow (R).
- ③ Field convertible to horizontal mounting or order operator only and separate operator cap.
- ④ For selection of the proper cam and contact block to obtain the proper circuit sequence, see selection instructions and tables on **Pages V7-T1-238, V7-T1-239 and V7-T1-240**.
- ⑤ Black lever selector switch, cam 3 shown.



### Selector Switch Operators without Caps

Operators can be ordered with caps assembled to them by adding the code number from the table on this page to the end of catalog number below.  
Example: 10250T4011**KB**

#### Two-Position Selector Switch Maintained



### Selector Switch Operators without Caps

Positions	Operator Action ①	Cam Code ②	Catalog Number
Two-position—60° throw		1	<b>10250T4011</b>
		1	<b>10250T4081</b>
Three-position—60° throw		2	<b>10250T4022</b>
		3	<b>10250T4023</b>
		2	<b>10250T4032</b>
		3	<b>10250T4033</b>
		2	<b>10250T4042</b>
		3	<b>10250T4043</b>
Four-position—40° throw		2	<b>10250T4052</b>
		3	<b>10250T4053</b>
		7	<b>10250T4067</b>

#### Knob



#### Lever



#### Lever for Use with Maintained Operators



#### Coin Slot



### Operating Caps

Color	Knob Catalog and Code Number	Lever Catalog and Code Number	Color	Lever ③ Catalog and Code Number	Coin Slot Catalog and Code Number
Black	<b>10250TKB</b>	<b>10250TLB</b>	Black	<b>10250TSB</b>	<b>10250TCB</b>
Red	<b>10250TKR</b>	<b>10250TLR</b>	Red	<b>10250TSR</b>	<b>10250TCR</b>
Green	<b>10250TKG</b>	<b>10250TLG</b>	Green	<b>10250TSG</b>	<b>10250TCG</b>
Yellow	<b>10250TKY</b>	<b>10250TLY</b>	Yellow	<b>10250TSY</b>	<b>10250TCY</b>
White	<b>10250TKW</b>	<b>10250TLW</b>	White	<b>10250TSW</b>	<b>10250TCW</b>
Gray	<b>10250TKA</b>	<b>10250TLA</b>	Gray	<b>10250TSA</b>	<b>10250TCA</b>
Blue	<b>10250TKL</b>	<b>10250TLL</b>	Blue	<b>10250TSL</b>	<b>10250TCL</b>
Orange	<b>10250TKD</b>	<b>10250TLO</b>	Orange	<b>10250TSO</b>	<b>10250TCO</b>

#### Notes

- ① M = Maintained. S = Spring return in direction of arrow (R).
- ② For selection of the proper cam and contact block to obtain the proper circuit sequence, see selection instructions and tables on **Pages V7-T1-238, V7-T1-239 and V7-T1-240**.
- ③ Designed for added ingress protection. For use in maintained operators only.



**Knob-Operated  
Selector Switch  
Operator**

### 10250T Style Operator Replacement Parts

Item No.	Description	No. Req.	Part Number
1	Gasket	1	<b>16-1548</b>
2	Mounting nut	1	<b>15-1530</b>
3	Handle	1	<b>24-5045</b>
4	Knob	1	<b>53-3157</b>
	Knob (not shown) for joystick operator with latch	1	<b>53-3159</b>
5	Common gate (supplied with operator)	2	<b>16-3400</b>
6	Set screw (#6-32 x 0.250 in long hollow hex)	2	<b>11-2014</b>
7	Mushroom head button (includes [2] Item 6)	1	<b>As Req. Below</b>
	Black	—	<b>53-1317</b>
	Red	—	<b>53-1317-2</b>
	Yellow	—	<b>53-1317-3</b>
	Green	—	<b>53-1317-4</b>
	Blue	—	<b>53-1317-22</b>
8	Set screw (#10-32 x 0.250 in long hollow hex)	2	<b>11-544</b>
9	Jumbo mushroom head button (aluminum—includes [2] Item 8)	1	<b>As Req. Below</b>
	Red	—	<b>53-1317-9</b>
	Black	—	<b>53-1317-10</b>
	Yellow	—	<b>53-1317-11</b>
	Green	—	<b>53-1317-12</b>
10	Jumbo mushroom head button (aluminum—red EMERG. STOP) does not include Item 8	1	<b>53-1349-18</b>
11	Position gate:		
	Two-position	1	<b>54-7278</b>
	Three-position	1	<b>54-7173</b>
	Four-position	1	<b>54-12278</b>
	Eight-position	1	<b>54-12279</b>
12	Mounting screw (#6-32 x 0.710 in long)	2	<b>10250TA79</b>
	Washer	2	<b>16-2038</b>
13	Terminal screw and lug (captiv)	Req.	<b>80-5502KIT</b>

Item No.	Description	No. Req.	Part Number
14	Gasket (supplied with basic unit)	1	<b>32-803</b>
15	Round head screw (#4-40 x 0.344 in long) (supplied with basic unit)	2	<b>11-4553</b>
16	Mounting screw	2	<b>11-1632</b>
17	Simple potentiometer (does not include items 18, 28 or 29)	1	<b>As Req. Below</b>
	1,000 ohms	—	<b>41-782-2</b>
	2,500 ohms	—	<b>41-782-3</b>
	5,000 ohms	—	<b>41-782-10</b>
	10,000 ohms	—	<b>41-782-4</b>
	25,000 ohms	—	<b>41-782-5</b>
	50,000 ohms	—	<b>41-782-6</b>
18	Connector (includes screw and lug)	2	<b>25-1851</b>
19	Indicating plate	1	<b>As Req. Above</b>
	Standard size (without legend)	—	<b>30-4460</b>
	Large size (specify legend)	—	<b>10250TR30</b>
20	Retaining nut	1	<b>15-1547</b>
21	Knob	1	<b>53-1314</b>
	Socket set screw (#6-32 x 0.250 in long)	2	<b>11-2014</b>
22	Coupling	1	<b>29-3749-2</b>
23	Set screw (#6-32 x 0.188 in long)	1	<b>11-1199</b>
24	Spacer	2	<b>56-1066-18</b>
25	Connector (includes screw and lug)	1	<b>25-1851-2</b>
26	Mounting nut	1	<b>15-1938</b>
27	Four-position joystick operating mechanism (complete)	1	<b>24-6565</b>
28	Four-position joystick operating mechanism (not shown) (with latch) complete	1	<b>24-6565-2</b>
29	Spring loaded latch	1	<b>52-1214-2</b>
30	Hand operated latch	1	<b>52-913-3</b>

## Technical Data and Specifications

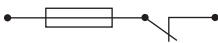
### Mechanical Ratings

Description	Specification
<b>Frequency of Operation</b>	
All pushbuttons	6000 operations/hr.
Key and lever selection switches	3000 operations/hr.
Auto-latch devices	1200 operations/hr.
<b>Life</b>	
Pushbuttons	10 x 10 <sup>6</sup> operations
Contact blocks	10 x 10 <sup>6</sup> operations
PresTest units	10 x 10 <sup>6</sup> operations
Lever and key selector switches	0.25 x 10 <sup>6</sup> operations
Twist to release pushbuttons	0.3 x 10 <sup>6</sup> operations
<b>Shock Resistance</b>	
Duration	20 ms ≥5g

### General Specifications

Description	Specification
<b>Climate Conditions</b>	
Operating temperature	1° to 150°F (–17° to 66°C)
Storage temperature	–40° to 176°F (–40° to 80°C)
Altitude	6,562 ft (2,000m)
Humidity	Max. 95% RH at 60°C
<b>Terminals</b>	
Marking	NC-NO on the contact block to meet the NEMA requirements. Dual marking system 1–2 for normally closed, 3–4 for normally open to meet BS5472 (Cenelec EN50 005).
Clamps	Terminals are saddle clamp type for 1 x 22 AWG (0.34 mm <sup>2</sup> ) to 2 x 14 AWG (2.5 mm <sup>2</sup> ) conductors
Torque	7 lb-in (0.8 Nm)
Degree of protection against direct electrical contact	IP2X with fingerproof shroud
<b>Light Units</b>	
Transformers	Will withstand short-circuit for 1 hour per IEC 60997-5-1
Bulbs—average life:	
Transformer type	20,000 hrs.
Resistor/direct voltage type	2500 hrs. minimum at rated voltage
LED	60,000 to 100,000 hrs.

#### Electrical Ratings

Description	Specification
Insulation	$U_i = 660 \text{ Vac or Vdc}$
Thermal	$I_{th} = 10\text{A}$
<b>Short Circuit Coordination to IEC/EN 60947-5-1</b>	
Rated conditional short circuit current	1 kA
Fuse type	GE power controls TIA 10, red spot type gG, 10A, 660 Vac, 460 Vdc, BS88-2, IEC 60269-2-1
	
UL rating	A600, P600
AC load life duty cycle 1200 operations/hour	
10A	110V pf 0.4— $1 \times 10^6$ operations
5A	250V pf 0.4— $1 \times 10^6$ operations
2A	600V pf 0.4— $1 \times 10^6$ operations
Switching capacity	
AC 15 rated make/break ( $11 \times I_b$ at $1.1 \times U_e$ )	
6A	120V pf 0.3
4A	240V pf 0.3
2A	660V pf 0.3
DC13 rated make/break ( $1.1 \times I_b$ at $1.1 \times U_e$ )	
1.0A	125V L/R $\geq 0.95$ at 300 ms
0.55A	250V L/R $\geq 0.95$ at 300 ms
0.1A	660V L/R $\geq 0.95$ at 300 ms
10A	110V pure resistive
Maximum ratings for logic level and hostile atmosphere application	
Maximum amperes	0.5A
Maximum volts	120 Vac/Vdc

#### Electrical Ratings—Contact Block

Description	50 Vac or 60 Hz				Vdc		
	120	240	480	600	24/28	125	250
<b>Meet or Exceed NEMA Rating Designations A600, A300 and B300 for AC and P600 for DC</b>							
Make and emerg. interrupting capacity (amp)	60	30	15	12	5.7	1.1	0.55
Normal load break (amp)	6	3	1.5	1.2	5.7	1.1	0.55
Thermal current (amp)	10	10	10	10	5.0	5.0	5.0
Voltamperes:							
Make and emerg. interrupting capacity	7200	7200	7200	7200	138	138	138
Normal load break	720	720	720	720	138	138	138

### Mounting Options

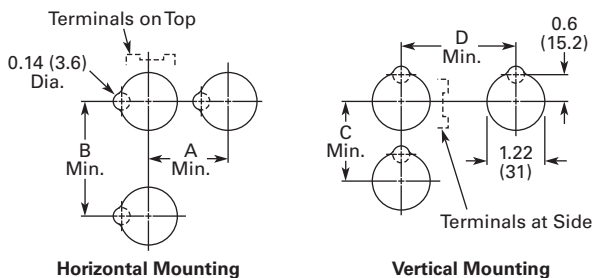
#### Panel Thickness

- Minimum: 0.06 in (1.6 mm)
- Maximum: 0.25 in (8 mm) including legend plate
- Maximum can be increased to 0.375 in (15.9 mm) using optional retaining nut
  - Indicating light: 10250TA30
  - Pushbutton/selector switch: 10250TA31

### Mounting Matrix

Legend Plate	Dimensions in Inches (mm)			
	A	B	C	D
Small	1.63 (41.3)	2.25 (57.2)	2.25 (57.2)	1.63 (41.3)
Medium	1.75 (44.5)	2.25 (57.2)	2.25 (57.2)	1.75 (44.5)
Large	2.25 (57.2)	2.25 (57.2)	2.25 (57.2)	2.25 (57.2)

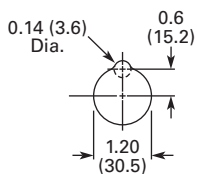
### Mounting Options in Inches (mm)



Horizontal mounting means terminals are located top and bottom of contact block. Vertical mounting means terminals are left and right of contact block. This allows close spacing of adjacent operators with easy access to terminals.

Locating nib hole or notch is 0.14 in (3.6 mm) #29 drill.

### Drilling Dimensions in Inches (mm)



THIS PAGE LEFT BLANK

# Eaton 10250T101

Catalog Number: 10250T101

Eaton 10250T pushbutton, 30.5 mm, Heavy-Duty Watertight/Oiltight Pushbutton, Class I Division 2, Black, Plastic Actuator, Chrome bezel, Non-illuminated, Flush mounting, Momentary, 30.5 mm, Flush Pushbutton, 10250T Series

## General specifications



<b>Product Name</b>	<b>Catalog Number</b>
Eaton 10250T pushbutton	10250T101
<b>UPC</b>	<b>Product Length/Depth</b>
782113203270	1.9 in
<b>Product Height</b>	<b>Product Width</b>
2 in	1.8 in
<b>Product Weight</b>	<b>Warranty</b>
0.22 lb	1 year
<b>Compliances</b>	<b>Certifications</b>
CE Marked	UL Listed
	CSA Certified

## Product specifications

### Product category

Flush pushbutton

### Series

10250T

### Type

Class I division 2

### Actuator color

Black

### Operating mode

Momentary

### Actuator material

Plastic

### Rating

NEMA 3R

NEMA 12

NEMA 4

NEMA 4X

NEMA 3

NEMA 13

### Illumination

Non-illuminated

### Size

30.5 mm

### Mounting method

Flush

### Bezel

Chrome

### Degree of protection

NEMA 4X

NEMA 13

NEMA 3R

NEMA 12

NEMA 3

NEMA 4

## Resources

### Catalogs

Eaton's Volume 7—Logic Control, Operator Interface and Connectivity Solutions

### Multimedia

How to size and select a Power Supply

### Specifications and datasheets

Eaton Specification Sheet - 10250T101





Eaton Corporation plc  
Eaton House  
30 Pembroke Road  
Dublin 4, Ireland  
Eaton.com  
© 2023 Eaton. All Rights Reserved.

Eaton is a registered trademark.

All other trademarks are property of their respective owners.



[Eaton.com/socialmedia](https://www.eaton.com/socialmedia)

THIS PAGE LEFT BLANK

### 30.5 mm Heavy-Duty Watertight/Oiltight—10250T



### Contents

<i>Description</i>	<i>Page</i>
30.5 mm Heavy-Duty Watertight/Oiltight—10250T	
Product Overview . . . . .	V7-T1-214
Product Identification . . . . .	V7-T1-214
Catalog Number Selection . . . . .	V7-T1-215
Product Selection	
Point-of-Purchase Packaging . . . . .	V7-T1-217
Non-Illuminated Momentary Pushbutton Units . . . . .	V7-T1-218
Pushbuttons . . . . .	V7-T1-219
Illuminated Momentary Pushbutton Units . . . . .	V7-T1-222
Indicating Light Units . . . . .	V7-T1-223
Illuminated Pushbuttons and Indicating Lights . . . . .	V7-T1-224
Push-Pull Emergency Stop . . . . .	V7-T1-226
Illuminated Push-Pull Units . . . . .	V7-T1-229
Potentiometers . . . . .	V7-T1-232
Push-Pull Operators . . . . .	V7-T1-233
Selector Switch Units . . . . .	V7-T1-237
Selector Switch Selection . . . . .	V7-T1-238
Selector Switch Operators . . . . .	V7-T1-241
Illuminated Selector Switch Operators . . . . .	V7-T1-244
Joystick Units . . . . .	V7-T1-245
Joysticks . . . . .	V7-T1-246
Roto-Push Units . . . . .	V7-T1-249
Roto-Push Operators . . . . .	V7-T1-250
Accessories . . . . .	V7-T1-255
Options . . . . .	V7-T1-260
Replacement Parts . . . . .	V7-T1-269
Technical Data and Specifications . . . . .	V7-T1-271
Dimensions . . . . .	V7-T1-274



### Application Description

#### Contact Operation

Slow make and break. All normally closed contacts have positive opening operation, i.e., normally closed contacts are forced open in the event of contact weld or spring breakage.

### Standards and Certifications

- CE EN 60947-5-1 and 60947-5-5
- UL 508—File No. 131568
- CSA C22.2 No. 14—File No. LR68551



### Ingress Protection

When mounted in similarly rated enclosure—

- Standard indicating lights
  - UL (NEMA) Type 1, 2, 3, 3R, 3S, 4, 4X, 12, 13
  - IEC IP65
- Most other operators
  - UL (NEMA) Type 1, 2, 3, 3R, 4, 4X, 12, 13
  - IEC IP65

### Product Description

The 30.5 mm pushbutton line features a zinc die cast construction with chrome-plated housing and mounting nut. The same durable construction is also available with the corrosive resistant E34 line of pushbuttons. See E34 section on **Pages V7-T1-284 to V7-T1-325**.

### Features

- Heavy-duty zinc die cast construction
- Enclosed silver contacts with reliability nibs
- Diaphragm seals with drainage holes
- Grounding nibs on the operator casing

### Benefits

- Reliability nibs improve contact reliability even under dry circuit and fine dust conditions
- Drainage holes prevent buildup of liquid inside the operator which can prevent operation in freezing environments
- Grounding nibs bit through paint and other coatings to provide secure ground

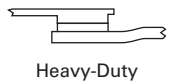
#### 1

### Product Overview

#### Reliability Nibs

Eaton's contact blocks feature enclosed silver contacts with pointed "reliability nibs" for reliable performance from logic level up to 600V. To ensure reliable switching, nibs bite through oxide which can form on silver contacts, eliminating the need for expensive logic level blocks for most applications.

#### Reliability Nibs



Reliability nibs improve performance in dry circuit, corrosive, fine dust and other contaminated atmospheres. Under normal environmental conditions, the minimum operational voltage is 5V and the minimum operational current is 1 mA, AC/DC. For operation under a wider range of environmental conditions, logic level contact blocks with inert palladium tipped contacts are recommended.

#### Grounding Nibs

10250T line operators have "grounding nibs"—four metal points on the operator casting designed to bite through most paints and other coatings on metal panels to enhance the ground connection when the operator is securely tightened.

#### Grounding Nibs

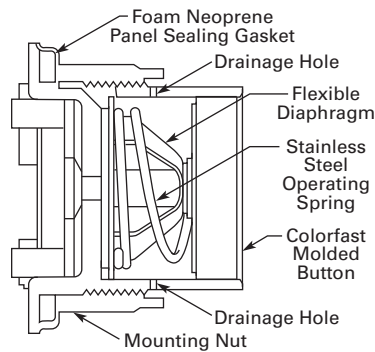


#### Diaphragm Seal with Drainage Holes

##### Liquid Drainage

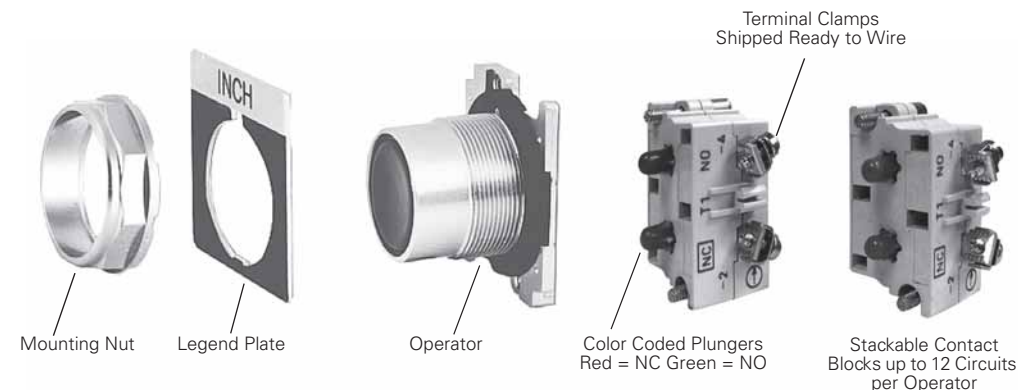
Eaton's pushbutton operators offer front of panel drainage via holes in the operator bushing. Hidden from view by the mounting nut, these holes prevent buildup of liquid inside the operator, which can prevent operation in freezing environments. The holes also provide a route for escaping liquid in high pressure washdowns, effectively relieving pressure from the internal diaphragm seal, ensuring reliable sealing in applications even beyond NEMA 4.

#### Diaphragm Seal



### Product Identification







#### 30.5 mm Heavy-Duty Watertight/Oiltight—10250T Series



### Pushbuttons

UL (NEMA) Type 3, 3R, 4, 4X, 12, 13

#### Momentary Pushbutton Operators, Non-illuminated

	Button	Color	Catalog Number			
 <p><b>10250T10_</b></p>	Flush button <sup>①</sup>	Black	<b>10250T101</b>			
		Red	10250T102			
		Green	10250T103			
		Yellow	10250T104			
		Gray	10250T105			
		White	10250T106			
		Blue	10250T108			
		Orange	10250T109			
		 <p><b>10250T11_</b></p>	Extended button	Black	10250T111	
Red	10250T112					
Green	10250T113					
Yellow	10250T120					
White	10250T116					
Blue	10250T118					
Orange	10250T119					
 <p><b>10250T5_</b></p>	Half shrouded button				<b>Vertical</b>	<b>Horizontal</b>
				Black	10250T501	10250T511
		Red	10250T502	10250T512		
		Green	10250T503	10250T513		
		Yellow	10250T504	10250T514		
		Gray	10250T505	10250T515		
		White	10250T506	10250T516		
		Blue	10250T508	10250T518		
		Orange	10250T509	10250T519		
		 <p><b>10250T12_</b></p>	Mushroom button	Black	10250T121	
Red	10250T122					
Green	10250T123					
Yellow	10250T124					
Blue	10250T129					
 <p><b>10250T17_</b></p>	Jumbo mushroom button <sup>②</sup>	Black	10250T171			
		Red	10250T172			
		Red (EMERG. STOP)	10250T17213			
		Green	10250T173			
		Yellow	10250T174			
 <p><b>10250ED1164_</b></p>	Low operating force—jumbo mushroom <sup>②③</sup>	Black	10250ED1164-2			
		Red	10250ED1164-3			
		Green	10250ED1164-4			
		Yellow	10250ED1164-5			
		Clear	10250ED1164			

**Note:** To order complete assembled unit using one composite catalog number, add contact block and legend plate suffix to the end of operator catalog number. Example: 10250T101-1TS33



**Operator**  
10250T101

+



**Contact Block**  
10250T1

+



**Legend Plate**  
10250TS33

#### Notes

- ① To order operator with factory assembled extended retaining nut, **10250TA12**, for thick panel applications, add suffix letter **E** to listed catalog number. Example: 10250T101E.
- ② Anodized aluminum head is not suitable for use in ultraviolet light applications.
- ③ Operating force—Standard = 2.4 lb; low force = 1.6 lb.



**Flush Head  
Pushbutton  
Operator**

### 10250T Style Operator Replacement Parts

Item No.	Description	No. Req.	Part Number
1	Gasket	1	<b>16-1548</b>
2	Mounting nut	1	<b>15-1530</b>
3	Handle	1	<b>24-5045</b>
4	Knob	1	<b>53-3157</b>
	Knob (not shown) for joystick operator with latch	1	<b>53-3159</b>
5	Common gate (supplied with operator)	2	<b>16-3400</b>
6	Set screw (#6-32 x 0.250 in long hollow hex)	2	<b>11-2014</b>
7	Mushroom head button (includes [2] Item 6)	1	<b>As Req. Below</b>
	Black	—	<b>53-1317</b>
	Red	—	<b>53-1317-2</b>
	Yellow	—	<b>53-1317-3</b>
	Green	—	<b>53-1317-4</b>
	Blue	—	<b>53-1317-22</b>
8	Set screw (#10-32 x 0.250 in long hollow hex)	2	<b>11-544</b>
9	Jumbo mushroom head button (aluminum—includes [2] Item 8)	1	<b>As Req. Below</b>
	Red	—	<b>53-1317-9</b>
	Black	—	<b>53-1317-10</b>
	Yellow	—	<b>53-1317-11</b>
	Green	—	<b>53-1317-12</b>
10	Jumbo mushroom head button (aluminum—red EMERG. STOP) does not include Item 8	1	<b>53-1349-18</b>
11	Position gate:		
	Two-position	1	<b>54-7278</b>
	Three-position	1	<b>54-7173</b>
	Four-position	1	<b>54-12278</b>
	Eight-position	1	<b>54-12279</b>
12	Mounting screw (#6-32 x 0.710 in long)	2	<b>10250TA79</b>
	Washer	2	<b>16-2038</b>
13	Terminal screw and lug (captiv)	Req.	<b>80-5502KIT</b>

Item No.	Description	No. Req.	Part Number
14	Gasket (supplied with basic unit)	1	<b>32-803</b>
15	Round head screw (#4-40 x 0.344 in long) (supplied with basic unit)	2	<b>11-4553</b>
16	Mounting screw	2	<b>11-1632</b>
17	Simple potentiometer (does not include items 18, 28 or 29)	1	<b>As Req. Below</b>
	1,000 ohms	—	<b>41-782-2</b>
	2,500 ohms	—	<b>41-782-3</b>
	5,000 ohms	—	<b>41-782-10</b>
	10,000 ohms	—	<b>41-782-4</b>
	25,000 ohms	—	<b>41-782-5</b>
	50,000 ohms	—	<b>41-782-6</b>
18	Connector (includes screw and lug)	2	<b>25-1851</b>
19	Indicating plate	1	<b>As Req. Above</b>
	Standard size (without legend)	—	<b>30-4460</b>
	Large size (specify legend)	—	<b>10250TR30</b>
20	Retaining nut	1	<b>15-1547</b>
21	Knob	1	<b>53-1314</b>
	Socket set screw (#6-32 x 0.250 in long)	2	<b>11-2014</b>
22	Coupling	1	<b>29-3749-2</b>
23	Set screw (#6-32 x 0.188 in long)	1	<b>11-1199</b>
24	Spacer	2	<b>56-1066-18</b>
25	Connector (includes screw and lug)	1	<b>25-1851-2</b>
26	Mounting nut	1	<b>15-1938</b>
27	Four-position joystick operating mechanism (complete)	1	<b>24-6565</b>
28	Four-position joystick operating mechanism (not shown) (with latch) complete	1	<b>24-6565-2</b>
29	Spring loaded latch	1	<b>52-1214-2</b>
30	Hand operated latch	1	<b>52-913-3</b>

## Technical Data and Specifications

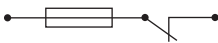
### Mechanical Ratings

Description	Specification
<b>Frequency of Operation</b>	
All pushbuttons	6000 operations/hr.
Key and lever selection switches	3000 operations/hr.
Auto-latch devices	1200 operations/hr.
<b>Life</b>	
Pushbuttons	10 x 10 <sup>6</sup> operations
Contact blocks	10 x 10 <sup>6</sup> operations
PresTest units	10 x 10 <sup>6</sup> operations
Lever and key selector switches	0.25 x 10 <sup>6</sup> operations
Twist to release pushbuttons	0.3 x 10 <sup>6</sup> operations
<b>Shock Resistance</b>	
Duration	20 ms ≥5g

### General Specifications

Description	Specification
<b>Climate Conditions</b>	
Operating temperature	1° to 150°F (–17° to 66°C)
Storage temperature	–40° to 176°F (–40° to 80°C)
Altitude	6,562 ft (2,000m)
Humidity	Max. 95% RH at 60°C
<b>Terminals</b>	
Marking	NC-NO on the contact block to meet the NEMA requirements. Dual marking system 1–2 for normally closed, 3–4 for normally open to meet BS5472 (Cenelec EN50 005).
Clamps	Terminals are saddle clamp type for 1 x 22 AWG (0.34 mm <sup>2</sup> ) to 2 x 14 AWG (2.5 mm <sup>2</sup> ) conductors
Torque	7 lb-in (0.8 Nm)
Degree of protection against direct electrical contact	IP2X with fingerproof shroud
<b>Light Units</b>	
Transformers	Will withstand short-circuit for 1 hour per IEC 60997-5-1
Bulbs—average life:	
Transformer type	20,000 hrs.
Resistor/direct voltage type	2500 hrs. minimum at rated voltage
LED	60,000 to 100,000 hrs.

#### Electrical Ratings

Description	Specification
Insulation	$U_i = 660 \text{ Vac or Vdc}$
Thermal	$I_{th} = 10\text{A}$
<b>Short Circuit Coordination to IEC/EN 60947-5-1</b>	
Rated conditional short circuit current	1 kA
Fuse type	GE power controls TIA 10, red spot type gG, 10A, 660 Vac, 460 Vdc, BS88-2, IEC 60269-2-1
	
UL rating	A600, P600
AC load life duty cycle 1200 operations/hour	
10A	110V pf 0.4— $1 \times 10^6$ operations
5A	250V pf 0.4— $1 \times 10^6$ operations
2A	600V pf 0.4— $1 \times 10^6$ operations
Switching capacity	
AC 15 rated make/break ( $11 \times I_b$ at $1.1 \times U_e$ )	
6A	120V pf 0.3
4A	240V pf 0.3
2A	660V pf 0.3
DC13 rated make/break ( $1.1 \times I_b$ at $1.1 \times U_e$ )	
1.0A	125V L/R $\geq 0.95$ at 300 ms
0.55A	250V L/R $\geq 0.95$ at 300 ms
0.1A	660V L/R $\geq 0.95$ at 300 ms
10A	110V pure resistive
Maximum ratings for logic level and hostile atmosphere application	
Maximum amperes	0.5A
Maximum volts	120 Vac/Vdc

#### Electrical Ratings—Contact Block

Description	50 Vac or 60 Hz				Vdc		
	120	240	480	600	24/28	125	250
<b>Meet or Exceed NEMA Rating Designations A600, A300 and B300 for AC and P600 for DC</b>							
Make and emerg. interrupting capacity (amp)	60	30	15	12	5.7	1.1	0.55
Normal load break (amp)	6	3	1.5	1.2	5.7	1.1	0.55
Thermal current (amp)	10	10	10	10	5.0	5.0	5.0
Voltamperes:							
Make and emerg. interrupting capacity	7200	7200	7200	7200	138	138	138
Normal load break	720	720	720	720	138	138	138



### Mounting Options

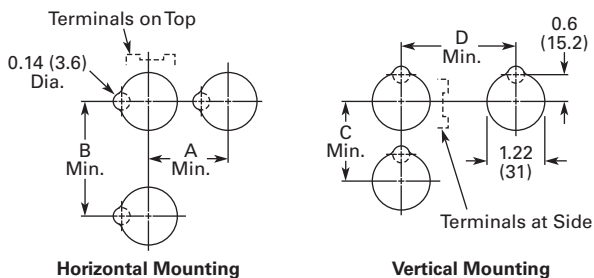
#### Panel Thickness

- Minimum: 0.06 in (1.6 mm)
- Maximum: 0.25 in (8 mm) including legend plate
- Maximum can be increased to 0.375 in (15.9 mm) using optional retaining nut
  - Indicating light: 10250TA30
  - Pushbutton/selector switch: 10250TA31

### Mounting Matrix

Legend Plate	Dimensions in Inches (mm)			
	A	B	C	D
Small	1.63 (41.3)	2.25 (57.2)	2.25 (57.2)	1.63 (41.3)
Medium	1.75 (44.5)	2.25 (57.2)	2.25 (57.2)	1.75 (44.5)
Large	2.25 (57.2)	2.25 (57.2)	2.25 (57.2)	2.25 (57.2)

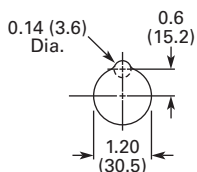
### Mounting Options in Inches (mm)



Horizontal mounting means terminals are located top and bottom of contact block. Vertical mounting means terminals are left and right of contact block. This allows close spacing of adjacent operators with easy access to terminals.

Locating nib hole or notch is 0.14 in (3.6 mm) #29 drill.

### Drilling Dimensions in Inches (mm)



THIS PAGE LEFT BLANK

# Eaton 10250T1

Catalog Number: 10250T1

Eaton 10250T pushbutton contact block, 10250T series, Standard Contact Block, Pressure terminal, 1NO-1NC

## General specifications

Product Name	Catalog Number
Eaton 10250T pushbutton contact block	10250T1
UPC	Product Length/Depth
782114263655	2.4 in
Product Height	Product Width
1 in	2 in
Product Weight	Warranty
0.08 lb	1 year
Compliances	Certifications
CE Marked	UL Listed
	CSA Certified

## Catalog Notes

Stack up to 6 blocks (12 circuits) unless otherwise noted



## Product specifications

### Contact configuration

1 NO-1 NC (standard)

### Series

10250T

### Type

30.5 mm, Heavy-Duty

### Terminals

Pressure

## Resources

### Brochures

[Pre-assembled enclosed emergency stop pushbutton control stations](#)

### Catalogs

[Eaton's Volume 7—Logic Control, Operator Interface and Connectivity Solutions](#)

### Multimedia

[How to size and select a Power Supply](#)

### Specifications and datasheets

[Eaton Specification Sheet - 10250T1](#)

[Cam selection for pushbutton selectors](#)



Eaton Corporation plc  
Eaton House  
30 Pembroke Road  
Dublin 4, Ireland  
Eaton.com

© 2023 Eaton. All Rights Reserved.

Eaton is a registered trademark.

All other trademarks are property of their respective owners.



[Eaton.com/socialmedia](https://www.eaton.com/socialmedia)

# Eaton 10250T2

Catalog Number: 10250T2

Eaton 10250T pushbutton contact block, 10250T series, Standard contact block, Pressure terminal, 2NO

## General specifications



<b>Product Name</b>	<b>Catalog Number</b>
Eaton 10250T pushbutton contact block	10250T2
<b>UPC</b>	<b>Product Length/Depth</b>
782113203423	1.1 in
<b>Product Height</b>	<b>Product Width</b>
0.1 in	1.2 in
<b>Product Weight</b>	<b>Warranty</b>
0.088 lb	1 year
<b>Compliances</b>	<b>Certifications</b>
CE Marked	UL Listed
	CSA Certified

## Catalog Notes

Stack up to 6 blocks (12 circuits) unless otherwise noted

## Product specifications

### Contact configuration

2 NO (standard)

### Series

10250T

### Type

30.5 mm, Heavy-Duty

### Terminals

Pressure

## Resources

### Brochures

[Pre-assembled enclosed emergency stop pushbutton control stations](#)

### Catalogs

[Eaton's Volume 7—Logic Control, Operator Interface and Connectivity Solutions](#)

### Multimedia

[How to size and select a Power Supply](#)

### Specifications and datasheets

[Eaton Specification Sheet - 10250T2](#)

[Cam selection for pushbutton selectors](#)



Eaton Corporation plc  
Eaton House  
30 Pembroke Road  
Dublin 4, Ireland  
Eaton.com

© 2023 Eaton. All Rights Reserved.

Eaton is a registered trademark.

All other trademarks are property of their respective owners.



[Eaton.com/socialmedia](https://www.eaton.com/socialmedia)

### Contact Blocks

#### Standard Contact Blocks

- UL A600/P600 rated
- Color-coded plungers—red/green for NC/NO circuits
- Silver contact tips with “reliability nibs”
- Gray (opaque) or amber (translucent) housings
- Pressure plate or spade terminals
- Fingerproof shrouds (for pressure terminals only)

#### Logic Level Contact Blocks

- UL A600/P600 rated
- Color-coded plungers
- Inert palladium knife-blade contacts
- Gray (opaque) housings
- Pressure plate or spade terminals

#### Special Function Contact Blocks

- UL A600/P600 rated
- Color-coded plungers
- Silver contact tips with “reliability nibs”
- Gray (opaque) housings
- Pressure plate terminals only

#### Special Purpose Contact Block

- Maximum 300V rated
- Black plungers
- Silver contact tips with “reliability nibs”
- Black (opaque) housings
- Pressure plate terminals only
- Fingerproof shrouds not available

#### Reliability Nibs

Reliability nibs are the hallmark of Eaton’s contact blocks. A pointed silver nib on the contact tip ensures reliable switching from logic level (5V) up to 600V applications. Therefore standard contact blocks can be used for most logic level applications where the contacts are not exposed to any harsh environmental conditions.

#### Palladium Contacts

Palladium, which is more inert than gold, is well suited for voltages and currents approaching zero and is recommended for applications where environmental conditions are a factor.

#### Maximum Contact Block Mounting per Operator Type

Operator	Max. Stack
Pushbuttons	6
Push-pull operators	2
Roto-push operators	4
Two- or three-position selector switches	6
Four-position selector switches	4
Joysticks	4

10250T1



Contact Blocks

Symbol	Circuit	Description <sup>①</sup>	Standard	Spade Terminal <sup>②</sup>	Logic Level	Spade Terminal <sup>②</sup>
			Pressure Terminal Catalog Number	Catalog Number	Pressure Terminal Catalog Number	Catalog Number
	Blank No Plunger 1NC	Stack up to six blocks (six circuits) unless otherwise noted.	<b>10250T51</b>	<b>10250T59</b>	<b>10250T51E</b>	<b>10250T59E</b>
	Blank No Plunger 1NO	Stack up to six blocks six circuits) unless otherwise noted.	<b>10250T53</b>	<b>10250T60</b>	<b>10250T53E</b>	<b>10250T60E</b>
	<b>NO-NC</b>	Stack up to six blocks (12 circuits) unless otherwise noted.	<b>10250T1</b>	<b>10250T40</b>	<b>10250T1E</b>	<b>10250T40E</b>
	2NC	Stack up to six blocks (12 circuits) unless otherwise noted.	<b>10250T3</b>	<b>10250T42</b>	<b>10250T3E</b>	<b>10250T42E</b>
	<b>2NO</b>	Stack up to six blocks (12 circuits) unless otherwise noted.	<b>10250T2</b>	<b>10250T41</b>	<b>10250T2E</b>	<b>10250T41E</b>
<b>Special Function Blocks <sup>③</sup></b>						
	Blank No Plunger LONC	Late opening NC. Stack up to six blocks (six circuits) unless otherwise noted.	<b>10250T71 <sup>③</sup></b>	—	<b>10250T71E <sup>③</sup></b>	—
	ECNO-NC	Early closing NO and standard NC. Stack up to six blocks unless otherwise noted.	<b>10250T47 <sup>③④</sup></b>	—	<b>10250T47E <sup>③</sup></b>	—
	ECNO-NO	Early closing NO and standard NO. Stack up to four blocks unless otherwise noted.	<b>10250T57 <sup>③④</sup></b>	—	<b>10250T57E <sup>③</sup></b>	—
	2LONC	Two late opening NC contacts. Stack up to six blocks unless otherwise noted.	<b>10250T45 <sup>③</sup></b>	—	<b>10250T45E <sup>③</sup></b>	—
	LONC-ECNO	Overlapping contacts. Stack up to four blocks unless otherwise noted.	<b>10250T55 <sup>③④</sup></b>	—	<b>10250T55E <sup>③</sup></b>	—
<b>Special Purpose Blocks <sup>⑤</sup></b>						
	2NO-2NC	Four circuits in single block depth. Rated 300V max. Stack up to four blocks unless otherwise noted.	<b>10250T44 <sup>⑤</sup></b>	—		

Notes

- ① All 10250T contact blocks shown are suitable for use on standard 10250T and E34 operators. These contact blocks are not suitable for Class I Division 2 type 10250T or E34 devices.
- ② Contact blocks with spade terminals are limited to a maximum of one contact block per operator and minimum spacing between devices is 2.5 in (63.5 mm). Not suitable for use in 10250T or E34 enclosures. Also available in amber housing. Not available with fingerproof shrouds.
- ③ Special function contact blocks are not suitable for use with roto-push operators, three-position push-pull operators, or four-position selector switches.
- ④ ECNO contact blocks are not suitable for use with two-position joysticks or when operators are used with padlock attachments.
- ⑤ Special purpose 10250T44 contact blocks are not suitable on selector switches or roto-push operators. Okay to use with three-position push-pull operators only on low voltage (30V or less) circuits. Fingerproof shrouds not available.



Products → Low Voltage Products and Systems → Connection Devices → Terminal Blocks → SNA Series

## General Information

<b>Extended Product Type:</b>	M4/8.SFL
<b>Product ID:</b>	1SNA115661R2100
<b>EAN:</b>	3472591156614
<b>Catalog Description:</b>	M4/8.SFL Screw Clamp Terminal Blocks - For 5 x 20 and 5 x 25 fuses - with blown fuse indicator - Grey
<b>Long Description:</b>	- Protect your circuits with 5x20 and 5x25 fuse terminal blocks (fuse not supplied with terminal blocks), - Quickly identify the defective circuit thanks to the blown fuse indicator.

## Ordering

<b>Color:</b>	Grey
<b>Minimum Order Quantity:</b>	50 piece
<b>Customs Tariff Number:</b>	85361010

## Popular Downloads

<b>Data Sheet, Technical Information:</b>	1SNC160019C0202
<b>Instructions and Manuals:</b>	1SNC160019C0202

## Dimensions

<b>Product Net Width:</b>	8 mm
<b>Product Net Height:</b>	56.5 mm
<b>Product Net Depth / Length:</b>	41 mm
<b>Product Net Weight:</b>	14 g

## Technical

<b>Rated Cross-Section:</b>	4 mm <sup>2</sup>
<b>Spacing:</b>	8 mm
<b>Connection Type:</b>	Screw clamp
<b>Function:</b>	Fuse
<b>Number of Levels:</b>	1
<b>Connecting Capacity Main Circuit:</b>	Screw Clamp / Flexible 1x 0.5 ... 4 mm <sup>2</sup> Screw Clamp / Rigid 1x 0.5 ... 6 mm <sup>2</sup>
<b>Gauge Type:</b>	A4
<b>Rated Current (I<sub>n</sub>):</b>	Main Circuit 6.3 A
<b>Rated Voltage (U<sub>r</sub>):</b>	400 V

<b>Rated Impulse Withstand Voltage</b> (U <sub>imp</sub> ):	4000 V
<b>Pollution Degree:</b>	3
<b>Degree of Protection:</b>	acc. to IEC 60529, IEC 60947-1, EN 60529 Main Terminals IP20
<b>Insulation Material:</b>	Polyamide
<b>Mounting on DIN Rail:</b>	G32 (32 x 15 mm Mounting Rail) acc. to IEC 60715 TH35-7.5 (35 x 7.5 mm Mounting Rail) acc. to IEC 60715 TH35-15 (35 x 15 mm Mounting Rail) acc. to IEC 60715
<b>Wire Stripping Length:</b>	9.5 mm
<b>Recommended Screw Driver:</b>	4 mm
<b>Tightening Torque:</b>	acc. IEC 60947-1 0.5 N·m Manufacturer 0.8 N·m

## Technical UL/CSA

<b>Maximum Operating Voltage</b> UL/CSA:	Main Circuit 600 V
<b>Connecting Capacity Main Circuit</b> UL/CSA:	Screw Clamp / Rigid 1x 22 ... 12 AWG
<b>Connecting Capacity UL/CSA:</b>	Screw Clamp / Rigid 22 ... 12 AWG Stranded 12 AWG
<b>Flammability According to UL94:</b>	V0

## Environmental

<b>Ambient Air Temperature:</b>	Operation -55 ... +110 °C Storage -55 ... +110 °C
<b>RoHS Status:</b>	Following EU Directive 2002/95/EC August 18, 2005 and amendment

## Certificates and Declarations (Document Number)

<b>CSA Certificate:</b>	1SND161066A0201
<b>cUL Certificate:</b>	1SND161002A0202
<b>Declaration of Conformity - CE:</b>	1SND225016U1000
<b>EAC Certificate:</b>	1SND161009A1100
<b>Environmental Information:</b>	1SND220021E1002
<b>Instructions and Manuals:</b>	1SNC160019C0202
<b>RMRS Certificate:</b>	1SND161007A1101
<b>RoHS Information:</b>	1SND230023F0208

## Classifications

<b>Object Classification Code:</b>	X
<b>ETIM 4:</b>	EC000899 - Fuse terminal block
<b>ETIM 5:</b>	EC000899 - Fuse terminal block

ETIM 6:

EC000899 - Fuse terminal block

## Container Information

<b>Package Level 1 Units:</b>	50 piece
<b>Package Level 1 Width:</b>	101 mm
<b>Package Level 1 Depth / Length:</b>	265 mm
<b>Package Level 1 Height:</b>	47 mm
<b>Package Level 1 Gross Weight:</b>	0.7 kg
<b>Package Level 1 EAN:</b>	3472591156614
<b>Package Level 2 Units:</b>	450 piece
<b>Package Level 2 Width:</b>	300 mm
<b>Package Level 2 Depth / Length:</b>	500 mm
<b>Package Level 2 Height:</b>	150 mm
<b>Package Level 2 Gross Weight:</b>	6.200 kg
<b>Package Level 3 Units:</b>	21600 piece
<b>Product Packing Type:</b>	Box



THIS PAGE LEFT BLANK

TE Internal #: 1SNA115661R2100

Modular Terminal Blocks, Fuse, Screw Clamp Terminal Block, Gray,  
Product Spacing .315 in [8 mm], 2 Position, Screw Terminal, Signal,  
DIN Rail

[View on TE.com >](#)


Connectors > Terminal Blocks & Strips > Modular Terminal Blocks

Block Function: **Fuse**Modular Terminal Block Product Type: **Screw Clamp Terminal Block**Primary Product Color: **Gray**Product Spacing: **8 mm [ .315 in ]**Number of Positions: **2**

## Features

### Product Type Features

Modular Terminal Block Product Type	Screw Clamp Terminal Block
-------------------------------------	----------------------------

### Configuration Features

Gauge Type	A4
Number of Levels	2
Block Function	Fuse
Number of Positions	2

### Electrical Characteristics

Voltage Rating (CSA)	600 V
Operating Voltage	400 VAC

### Body Features

Product Weight	14 g
Primary Product Color	Gray

### Contact Features

Contact Current Rating (Max)	6.3 A
------------------------------	-------

### Termination Features

Termination Method to Wire & Cable	Screw Terminal
------------------------------------	----------------

### Mechanical Attachment

Tightening Torque	7 in-lbs
DIN Rail Mounting Type	G32, TH35-15, TH35-7.5
Connector Mounting Type	DIN Rail

### Housing Features

Housing Material	Polyamide
------------------	-----------

### Dimensions

Main Circuit Capacity - 1 Rigid Stranded Conductor per Screw Clamp	.5 – 6 mm <sup>2</sup>
Main Circuit Capacity - 1 Flexible Conductor per Screw Clamp	.5 – 4 mm <sup>2</sup>
Wire Stripping Length	9.5 mm[.374 in]
Product Depth	41 mm[1.614 in]
Product Width	8 mm[.314 in]
Product Length	41 mm[1.614 in]
Product Height	56.5 mm[2.224 in]
Product Spacing	8 mm[.315 in]
Wire Size	4 mm <sup>2</sup>

### Usage Conditions

Operating Temperature Range	-55 – 110 °C[-67 – 230 °F]
-----------------------------	----------------------------

### Operation/Application

Circuit Application	Signal
---------------------	--------

### Industry Standards

IP Rating	IP20
UL Flammability Rating	UL 94V-0

## Product Compliance

For compliance documentation, visit the product page on [TE.com](#)>

EU RoHS Directive 2011/65/EU	Compliant
EU ELV Directive 2000/53/EC	Compliant
China RoHS 2 Directive MIIT Order No 32, 2016	No Restricted Materials Above Threshold
EU REACH Regulation (EC) No. 1907/2006	Current ECHA Candidate List: JUNE 2023 (235) Candidate List Declared Against: JAN 2021 (211) Does not contain REACH SVHC



Halogen Content

Not Yet Reviewed for halogen content

Solder Process Capability

Not reviewed for solder process capability

## Product Compliance Disclaimer

This information is provided based on reasonable inquiry of our suppliers and represents our current actual knowledge based on the information they provided. This information is subject to change. The part numbers that TE has identified as EU RoHS compliant have a maximum concentration of 0.1% by weight in homogenous materials for lead, hexavalent chromium, mercury, PBB, PBDE, DBP, BBP, DEHP, DIBP, and 0.01% for cadmium, or qualify for an exemption to these limits as defined in the Annexes of Directive 2011/65/EU (RoHS2). Finished electrical and electronic equipment products will be CE marked as required by Directive 2011/65/EU. Components may not be CE marked. Additionally, the part numbers that TE has identified as EU ELV compliant have a maximum concentration of 0.1% by weight in homogenous materials for lead, hexavalent chromium, and mercury, and 0.01% for cadmium, or qualify for an exemption to these limits as defined in the Annexes of Directive 2000/53/EC (ELV). Regarding the REACH Regulation, the information TE provides on SVHC in articles for this part number is based on the latest European Chemicals Agency (ECHA) 'Guidance on requirements for substances in articles' posted at this URL: <https://echa.europa.eu/guidance-documents/guidance-on-reach>

THIS PAGE LEFT BLANK



Products → Low Voltage Products and Systems → Connection Devices → Terminal Blocks Accessories  
→ End Sections

## General Information

<b>Extended Product Type:</b>	FEM8S
<b>Product ID:</b>	1SNA116951R1500
<b>EAN:</b>	3472591169515
<b>Catalog Description:</b>	FEM8S End Sections Grey
<b>Long Description:</b>	- Aligned with the profile of the block and snap on the open side of the block, - Coloured end sections can offer an easy and economical way to separate circuits for identification.

## Ordering

<b>Color:</b>	Grey
<b>Minimum Order Quantity:</b>	20 piece
<b>Customs Tariff Number:</b>	39269097

## Dimensions

<b>Product Net Width:</b>	4.2 mm
<b>Product Net Height:</b>	54 mm
<b>Product Net Depth / Length:</b>	32.5 mm
<b>Product Net Weight:</b>	2.6 g

## Technical

<b>Spacing:</b>	1.5 mm
<b>Function:</b>	End Sections
<b>Degree of Protection:</b>	acc. to IEC 60529, IEC 60947-1, EN 60529 Main Terminals IP20
<b>Insulation Material:</b>	Polyamide
<b>Suitable For:</b>	DR4/8SF M4/8 M4/8.SF M4/8.SF.NC M4/8.SF.R M4/8.SN

## Technical UL/CSA

<b>Flammability According to UL94:</b>	V0
--	----

## Environmental

**Ambient Air Temperature:** Operation -55 ... +110 °C  
Storage -55 ... +110 °C

## Certificates and Declarations (Document Number)

**Environmental Information:** 1SND220090E1000

---

**RoHS Information:** 1SND230478F0202

## Classifications

**Object Classification Code:** X

---

**E-number:** 2925615

---

**ETIM 4:** EC000886 - Endplate and partition plate for terminal block

---

**ETIM 5:** EC000886 - Endplate and partition plate for terminal block

---

**ETIM 6:** EC000886 - Endplate and partition plate for terminal block

## Container Information

**Package Level 1 Units:** 20 piece

---

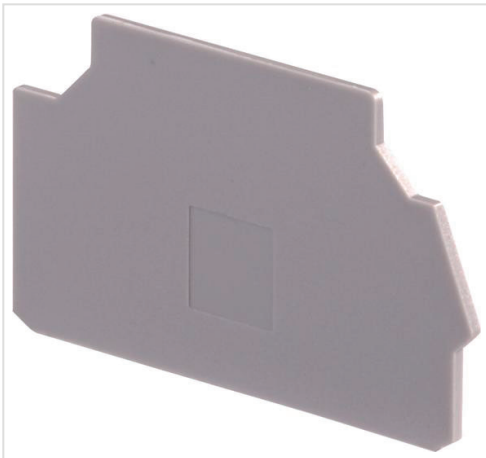
**Package Level 1 Gross Weight:** 0.052 kg

---

**Package Level 1 EAN:** 3472591169515

---

**Package Level 3 Units:** 72000 piece





## Product Compliance

[For compliance documentation, visit the product page on TE.com>](#)

EU RoHS Directive 2011/65/EU	Compliant
EU ELV Directive 2000/53/EC	Compliant
China RoHS 2 Directive MIIT Order No 32, 2016	No Restricted Materials Above Threshold
EU REACH Regulation (EC) No. 1907/2006	Current ECHA Candidate List: JUNE 2023 (235) Candidate List Declared Against: JUNE 2023 (235) Does not contain REACH SVHC
Halogen Content	Low Halogen - Br, Cl, F, I < 900 ppm per homogenous material. Also BFR/CFR/PVC Free
Solder Process Capability	Not reviewed for solder process capability

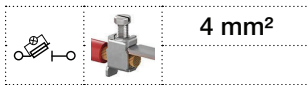
### Product Compliance Disclaimer

This information is provided based on reasonable inquiry of our suppliers and represents our current actual knowledge based on the information they provided. This information is subject to change. The part numbers that TE has identified as EU RoHS compliant have a maximum concentration of 0.1% by weight in homogenous materials for lead, hexavalent chromium, mercury, PBB, PBDE, DBP, BBP, DEHP, DIBP, and 0.01% for cadmium, or qualify for an exemption to these limits as defined in the Annexes of Directive 2011/65/EU (RoHS2). Finished electrical and electronic equipment products will be CE marked as required by Directive 2011/65/EU. Components may not be CE marked. Additionally, the part numbers that TE has identified as EU ELV compliant have a maximum concentration of 0.1% by weight in homogenous materials for lead, hexavalent chromium, and mercury, and 0.01% for cadmium, or qualify for an exemption to these limits as defined in the Annexes of Directive 2000/53/EC (ELV). Regarding the REACH Regulation, the information TE provides on SVHC in articles for this part number is based on the latest European Chemicals Agency (ECHA) 'Guidance on requirements for substances in articles' posted at this URL: <https://echa.europa.eu/guidance-documents/guidance-on-reach>

THIS PAGE LEFT BLANK

# M4/8.SF screw clamp terminal blocks

For 5x20 and 5x25 fuses - With blown fuse indicator - 8 mm 0.315 in spacing



4 mm<sup>2</sup>

## Description

- Protect your circuits with 5x20 and 5x25 fuse terminal blocks (fuse not supplied with terminal blocks),
- Quickly identify the defective circuit thanks to the blown fuse indicator.

## Ordering details

Description	Color	Type	Part Number	Pkg qty	Weight (1 pce) g
Fuse	Grey <input type="checkbox"/>	M4/8.SFD3	1SNA115935R0400	50	14.00

## Main technical data

Connecting capacity	IEC	UL	CSA
1 conductor per clamp	Rigid - Solid / Stranded Flexible with insulated ferrule Gauge	0.5-6 mm <sup>2</sup> 0.5-4 mm <sup>2</sup> A4	
Rated current / Rated cross section	6.3 A / 4 mm <sup>2</sup>		
Rated short-time withstand current (1s)			
Rated voltage	400 V		
Impulse withstand voltage	4000 V		
Protection	IP20	NEMA 1	

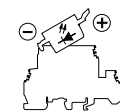
## Mounting instructions

Rail		G32, TH 35-7.5, TH 35-15
Wire stripping length		9.5 mm 0.374 in
Tool		Flat screwdriver Ø 4 mm Ø 0.157 in
Torque		0.5 - 0.8 N.m 4.4 - 7.1 lb.in

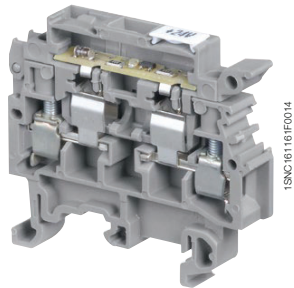
The connecting capacity data for one Rigid - Solid / Stranded - Flexible conductor (when applicable) is a mandatory information required by IEC, UL and CSA standards. All other data are provided as supplementary information only. For more details, please consult our CB, UL or CSA certificates and technical datasheet available on <http://www.te.com>

--	--	--

## Notes

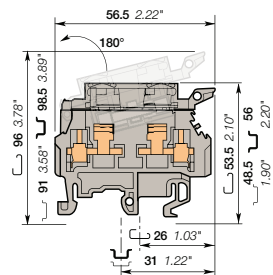


Blocks with LED indicator are labeled "+" on the outside of the lever. The indicator can be reversed in the field if required.  
Leakage current : 24 V : < 0.5 mA / 110 V : < 2.2 mA



1SNC161161F0014

M4/8.SF



8 mm 0.315 in spacing

## Accessories

Description	Color	Type	Part Number	Pkg qty	Weight (1 pce) g
1 End stops	Grey <input type="checkbox"/>	BAM4	1SNK900001R0000	50	12.00
		BAZ1	1SNK900002R0000	50	4.70
2 End sections	Grey <input type="checkbox"/>	FEM8S	1SNA116951R1500	20	2.60
3 Jumper bars	Grey <input type="checkbox"/>	AD2.5	1SNA114205R2000	50	1.60
4 Lateral jumper bars		PC81-10	1SNA173523R1100	10	5.00
5 Fuses		FU520	1SNA008288R1500	10	
			1SNA008289R1600	10	
			1SNA008290R1300	10	
			1SNA008291R0000	10	
			1SNA008292R0100	10	
6 Assembly rods		TGA8	1SNA168672R1100	10	1.00
			1SNA168673R1200	10	
			1SNA168674R1300	10	
7 Spring retaining rings		ANT	1SNA168675R1400	10	
8 Terminal block markers	White <input type="checkbox"/>	RC810	1SNA234000R0200	1	8.20

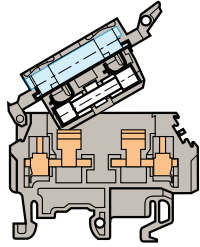
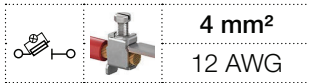
Complete list of accessories is indicated in the terminal block datasheet.

Some accessories such as jumper bars may modify the terminal block's ratings: complete information in the accessories catalogue pages.

Technical data valid for copper conductors only.

## M4/8.SF screw clamp terminal blocks

For 5x20 and 5x25 fuses - With blown fuse indicator - 8 mm 0.315 in spacing



8 mm 0.315 in spacing

### With blown fuse indicator

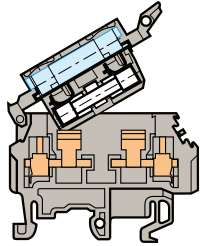
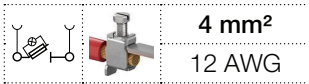
#### Ordering details

Description	Color	Type	Part Number	Pkg qty	Weight (1 pce) g
<b>Fuse</b> With blown fuse indicator by neon 110-230 V AC	Grey <input type="checkbox"/>	M4/8.SFL	1SNA115661R2100	50	14.00
With blown fuse indicator by LED 24 V AC/DC	Grey <input type="checkbox"/>	M4/8.SFD	1SNA115663R2300	50	14.00

Main technical data	IEC	UL	CSA	Leakage current :
<b>Rated voltage</b>	400 V	600 V	250 V	24 V : < 4.5 mA
<b>Impulse withstand voltage</b>	4000 V			110 V : < 0.5 mA
<b>Protection</b>	IP20	NEMA 1		230 V : < 0.7 mA



2



8 mm 0.315 in spacing

### With blown fuse indicator and 2 test socket DIA 2 mm 0.079 in

#### Ordering details

Description	Color	Type	Part Number	Pkg qty	Weight (1 pce) g
<b>Fuse</b> With blown fuse indicator by LED 24 V AC/DC and 2 test socket DIA 2 mm 0.079 in	Grey <input type="checkbox"/>	M4/8.SFDT	1SNA115665R2500	50	14.00
With blown fuse indicator by neon 110-230 V AC and 2 test socket DIA 2 mm 0.079 in	Grey <input type="checkbox"/>	M4/8.SFLT	1SNA115667R2700	50	14.00

Main technical data	IEC	UL	CSA	Leakage current :
<b>Rated voltage</b>	400 V	600 V	250 V	24 V : < 4.5 mA
<b>Impulse withstand voltage</b>	4000 V			110 V : < 0.5 mA
<b>Protection</b>	IP20	NEMA 1		230 V : < 0.7 mA



#### Accessories

Description	Color	Type	Part Number	Pkg qty	Weight (1 pce) g
<b>1 Test plugs</b> DIA 2 mm 0.079 in	Black <input checked="" type="checkbox"/>	FC2	1SNA007865R2600	100	



1

Technical data valid for copper conductors only.

1SNC161105S0201 - Rev. A

# 217 Series

## 5 × 20 mm, Fast-acting Fuse



### Description

5x20mm fast-acting glass body cartridge fuse designed to IEC specification.

### Features & Benefits

- Designed to International (IEC) Standards for use globally
- Meets the IEC 60127-2, Sheet 2 specification for fast-acting fuses
- Available in cartridge and axial lead form
- RoHS compliant and lead-free

### Applications

Used as supplementary protection in appliance or utilization equipment to provide individual protection for components or internal circuits.

### Additional Information



Resources



Accessories



Samples

### Agency Approvals

Agency	Agency File/Certificate Number	Ampere Range
PS	Cartridge: NBK090205-E10480A NBK120802-E10480C	1A – 5A 6.3A – 15A
	Leaded: NBK090205-E10480B NBK120802-E10480D	1A – 5A 6.3A – 15A
	2020970207000064	0.032A – 6.3A
CCC	SU05001-3004 SU05001-2005 SU05001-2006 SU05001-2007	0.032A-0.040A 0.050A-0.315A 0.400A-6.3A 8A-10A
cULus	E10480	0.032A – 10A
SP	29862	0.032A – 6.3A
S	SE-S-2100014	0.032A – 6.3A
D'E	40014645	0.032A – 6.3A, 8A*, 10A*
VDE	40016647	15A*
IEC	KM41462	0.040A – 6.3A
CE	N/A	0.032A – 15A
UKCA	N/A	0.032A – 15A

\*Approval for cartridge versions only

### Electrical Characteristics for Series

% of Ampere Rating	Ampere Rating	Opening Time
150%	0.032A–0.100A	60 minutes, Minimum
	0.125A-6.3A	60 minutes, Minimum
	8A-15A	30 minutes, Minimum
210%	0.032A-0.100A	30 minutes, Maximum
	0.125A-6.3A	30 minutes, Maximum
	8A-15A	30 minutes, Maximum
275%	0.032A-0.100A	0.01 sec., Min.; .5 sec. Max.
	0.125A-6.3A	0.05 sec., Min.; 2 sec. Max.
	8A-15A	0.05 sec., Min.; 2 sec. Max.
400%	0.032A-0.100A	.003 sec., Min.; 0.1 sec. Max.
	0.125A-6.3A	.01 sec., Min.; 0.3 sec. Max.
	8A-15A	.01 sec., Min.; 0.4 sec. Max.
1000%	0.032A-0.100A	.02 second, Maximum
	0.125A-6.3A	.02 second, Maximum
	8A-15A	.04 second, Maximum

# 217 Series

## 5 × 20 mm, Fast-acting Fuse

### Electrical Characteristic Specifications by Item

Amp Code	Amp Rating (A)	Voltage Rating (V)	Interrupting Rating	Nominal Cold Resistance (Ohms)	Nominal Melting I <sup>2</sup> t (A <sup>2</sup> sec)	Maximum Voltage Drop at Rated Current (mV)	Maximum Power Dissipation At 1.5I <sub>n</sub> (W)	Agency Approvals									
								UK CA	UL	CCC	PS E	RU	SF	S	CE	D'E	
.032	0.032	250	35A @ 250VAC	262.2000	0.00015	10000	1.6	x	-	x	x	-	x	x	x	x	x
.040	0.04	250		183.1500	0.00008	8000	1.6	x	-	x	x	-	x	x	x	x	x
.050	0.05	250		15.2000	0.00049	7000	1.6	x	-	x	x	-	x	x	x	x	x
.063	0.063	250		10.4500	0.00056	5000	1.6	x	-	x	x	-	x	x	x	x	x
.080	0.08	250		7.8900	0.00132	4000	1.6	x	-	x	x	-	x	x	x	x	x
.100	0.1	250		5.6965	0.0026	3500	1.6	x	-	x	x	-	x	x	x	x	x
.125	0.125	250		3.8200	0.00478	2000	1.6	x	-	x	x	-	x	x	x	x	x
.160	0.16	250		2.5250	0.01	2000	1.6	x	-	x	x	-	x	x	x	x	x
.200	0.2	250		1.7000	0.02	1700	1.6	x	-	x	x	-	x	x	x	x	x
.250	0.25	250		1.2325	0.04	1400	1.6	x	-	x	x	-	x	x	x	x	x
.315	0.315	250		0.8800	0.11	1300	1.6	x	-	x	x	-	x	x	x	x	x
.400	0.4	250		0.2770	0.125	1200	1.6	x	x	x	x	-	x	x	x	x	x
.500	0.5	250		0.2065	0.215	1000	1.6	x	x	x	x	-	x	x	x	x	x
.630	0.63	250		0.1900	0.41	650	1.6	x	x	x	x	-	x	x	x	x	x
.800	0.8	250		0.1203	0.85	240	1.6	x	x	x	x	-	x	x	x	x	x
1.00	1	250		0.0964	1.045	200	1.6	x	x	x	x	x	x	x	x	x	x
1.25	1.25	250		0.0701	2.23	200	1.6	x	x	x	x	x	x	x	x	x	x
1.60	1.6	250		0.0528	4.615	190	1.6	x	x	x	x	x	x	x	x	x	x
2.00	2	250		0.0416	5.73	170	1.6	x	x	x	x	x	x	x	x	x	x
2.50	2.5	250		0.0334	9.46	170	1.6	x	x	x	x	x	x	x	x	x	x
3.15	3.15	250	0.0224	17.72	150	2.5	x	x	x	x	x	x	x	x	x	x	
4.00	4	250	40A@250VAC 70A@60VDC	0.0165	29.165	130	2.5	x	x	x	x	x	x	x	x	x	
5.00	5	250	50A@250VAC 70A@60VDC	0.0137	42.795	130	2.5	x	x	x	x	x	x	x	x	x	
6.30	6.3	250	63A@250VAC 70A@60VDC	0.0095	62.465	130	2.5	x	x	x	x	x	x	x	x	x	
8.00	8	250	80A @ 250VAC	0.0068	198.16	130	4	x	-	x	-	x	x	-	-	x	x*
10.0	10	250	100A @ 250VAC	0.0063	217.635	130	4	x	-	x	-	x	x	-	-	x	x*
15.0	15	250	150A @ 250VAC	0.0040	607.135	130	4	x	-	-	-	x	-	-	-	x	x*

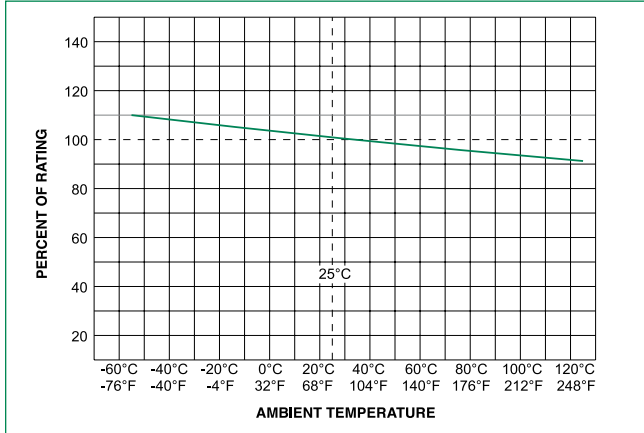
\* Approval for cartridge versions only.



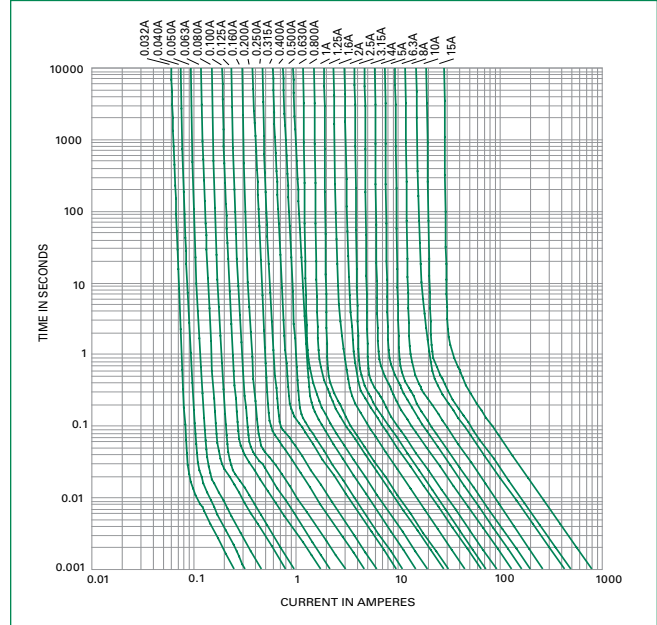
# 217 Series

## 5 × 20 mm, Fast-acting Fuse

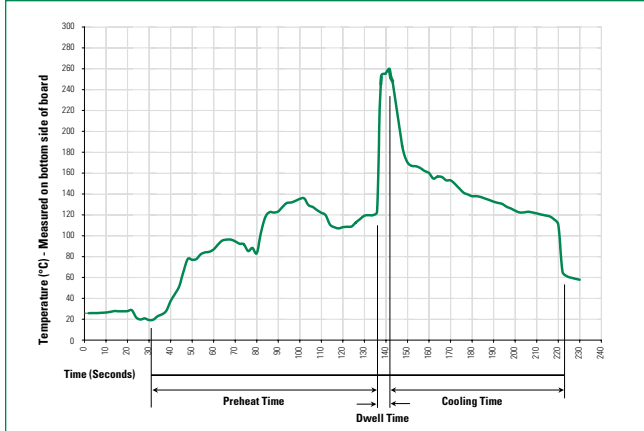
Temperature Re-rating Curve



Average Time Current Curves



### Soldering Parameters - Wave Soldering



### Recommended Process Parameters:

Wave Parameter	Lead-Free Recommendation
Preheat: (Depends on Flux Activation Temperature)	(Typical Industry Recommendation)
Temperature Minimum:	100°C
Temperature Maximum:	150°C
Preheat Time:	60-180 seconds
Solder Pot Temperature:	260°C Maximum
Solder Dwell Time:	2-5 seconds

### Recommended Hand-Solder Parameters:

Solder Iron Temperature: 350°C +/- 5°C  
 Heating Time: 5 seconds max.  
**Note:** These devices are not recommended for IR or Convection Reflow process.

### Product Characteristics

<b>Material</b>	Body: Glass Cap: Nickel-plated brass Leads: Tin-plated Copper
<b>Terminal Strength</b>	MIL-STD-202, Method 211, Test Condition A
<b>Solderability</b>	MIL-STD-202 method 208
<b>Product Marking</b>	Cap1: Brand logo, current and voltage ratings Cap2: Agency approval marks
<b>Packaging</b>	Available in Bulk (M=1000 pcs/pkg) or on Tape/Reel (MRET1=1000 pcs/reel)

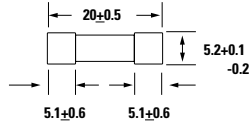
<b>Operating Temperature</b>	-55°C to +125°C
<b>Thermal Shock</b>	MIL-STD-202, Method 107, Test Condition B: (5 cycles -65°C to +125°C)
<b>Vibration</b>	MIL-STD-202, Method 201
<b>Humidity</b>	MIL-STD-202, Method 103, Test Condition A. high RH (95%) and elevated temperature (40°C) for 240 hours.
<b>Salt Spray</b>	MIL-STD-202, Method 101, Test Condition B

# 217 Series

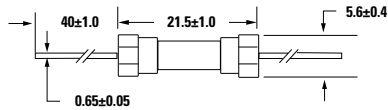
## 5 × 20 mm, Fast-acting Fuse

### Dimensions

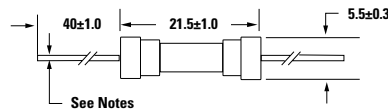
0217 000P



0217.032 XEP  
to  
0217.315 XEP



0217.400 XEP  
to  
0217015 XEP

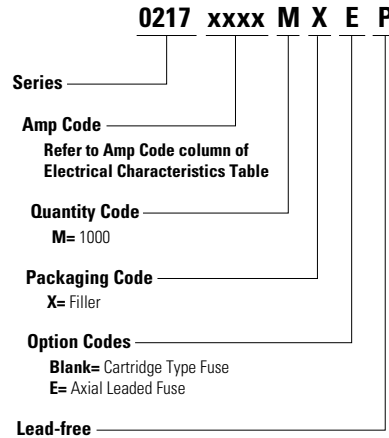


All dimensions in mm

**Notes:**

- \* 0.032A-6.3A have 0.65±0.05 diameter lead
- \* 8A-15A have 0.8±0.05 diameter lead

### Part Numbering System



### Packaging

Packaging Option	Packaging Specification	Quantity	Quantity & Packaging Code	Taping Width
<b>217 Series</b>				
Bulk	N/A	1000	MX	N/A
Bulk	N/A	1000	MXE	N/A
Reel and Tape	EIA 296-E	1000	MRET1	T1=53mm (2.087")
PGT With Color Code Bulk	N/A	1000	MXG	N/A
Cartridge With Color Code Bulk	N/A	1000	MXB	N/A
Bulk	N/A	100	HX	N/A

### Recommended Accessories

Accessory Type	Series	Description	Max Application Voltage	Max Application Amperage
Holder	<a href="#">345_ISF</a>	Panel Mount Shock-Safe Fuseholder	250	20
	<a href="#">345</a>	Shock-Safe Fuseholder with PC Mount, Solder Mount and Panel Mount options		20
	<a href="#">830</a>	PC Mount Shock-Safe Miniature Fuseholder		16
Block	<a href="#">520</a>	Metric OMNI-BLOK® Fuse Block		10
	<a href="#">646</a>	PC Mount Miniature Fuse Block		6.3
	<a href="#">658</a>	Surface Mount Miniature Fuse Block		10
Clip	<a href="#">520_W</a>	PC Mount Miniature Fuse Clip		6.3
	<a href="#">111</a>	PC Board Mount Fuse Clip		10
	<a href="#">445</a>	PC Board Mount Fuse Clip	10	

**Notes:**

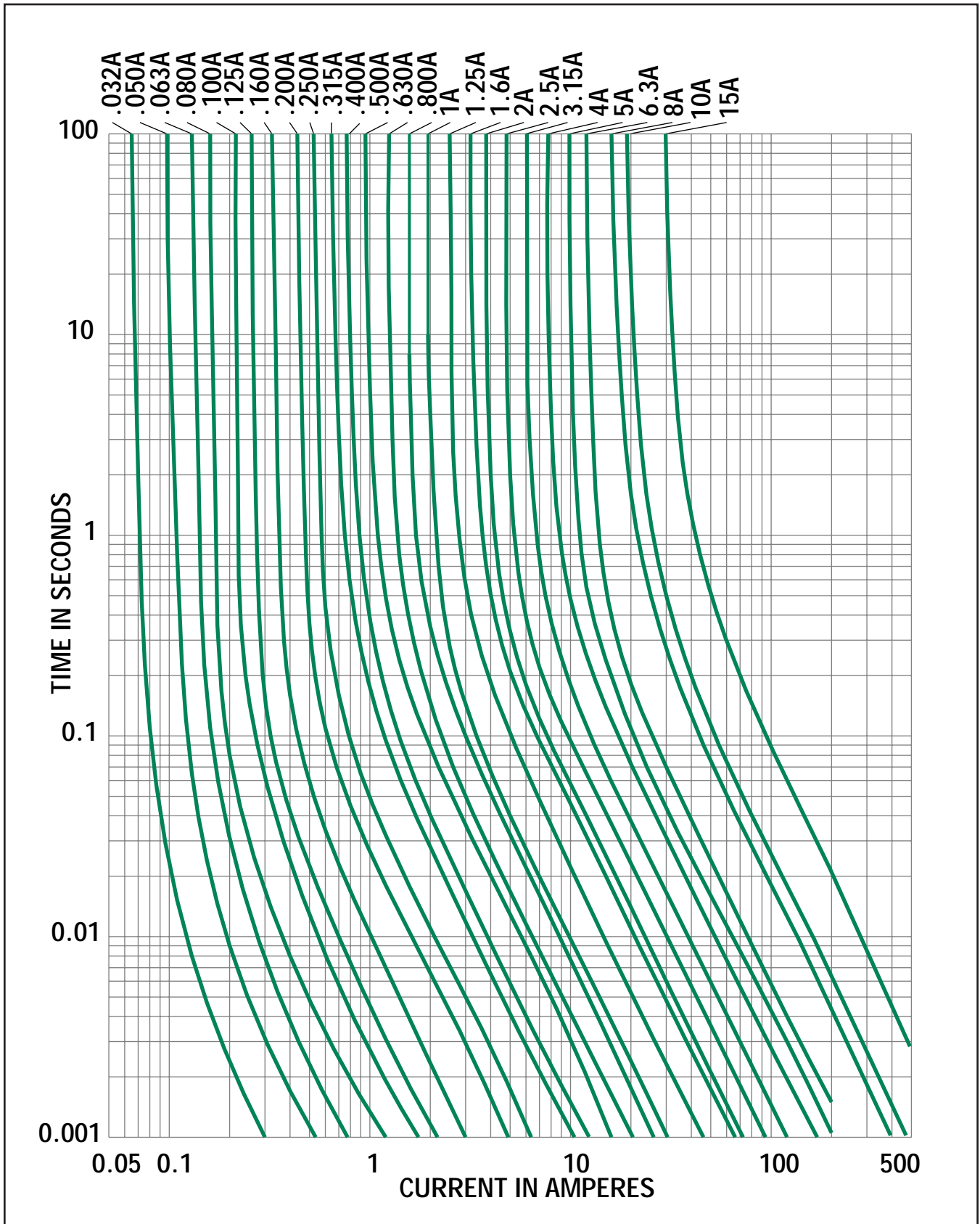
- Do not use in applications above rating.
- Please refer to fuseholder data sheet for specific re-rating information.
- Please contact factory for applications greater than the max voltage and amperage shown.

**Disclaimer Notice** - Information furnished is believed to be accurate and reliable. However, users should independently evaluate the suitability of and test each product selected for their own applications. Littelfuse products are not designed for, and may not be used in, all applications. Read complete Disclaimer Notice at <https://www.littelfuse.com/legal/disclaimers/product-disclaimer.aspx>.



**Littelfuse®**

**5x20mm Fast-Acting Fuse  
217 Series**



THIS PAGE LEFT BLANK