



**INSTRUCTIONS
AND
RENEWAL PARTS**

GEH-2007B
(SUPERSEDES GEI-28840A AND
GEF-3693)

AUTO-BLAST INTERRUPTER AND TRANSFER SWITCH

Types

**SE-5
SE-5-1
SE-5-2
SE-5-2A**

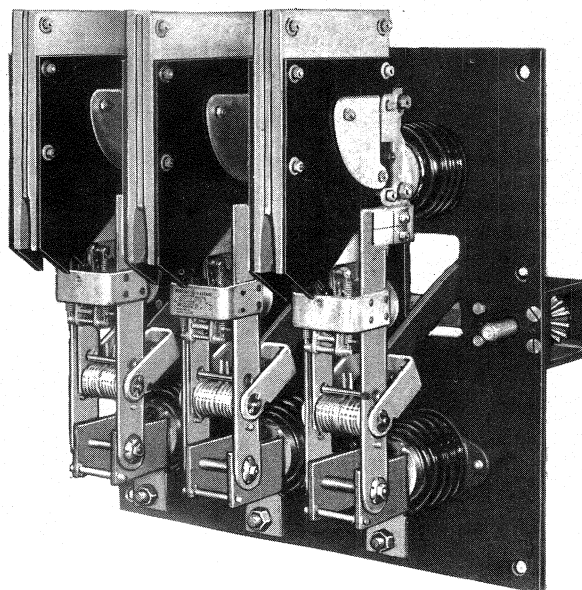

MEDIUM VOLTAGE SWITCHGEAR DEPARTMENT

GENERAL  ELECTRIC

PHILADELPHIA, PA.

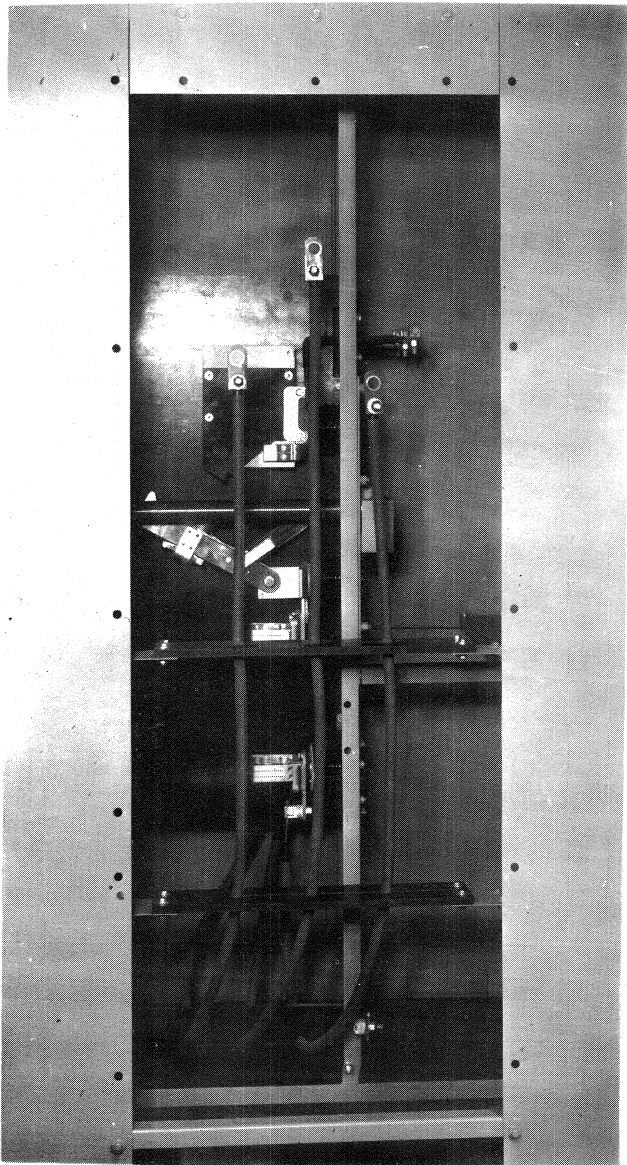

Fig. 1 Side View Of SE-5 Auto-blast Interrupter Switch Mounted In Metal Enclosure

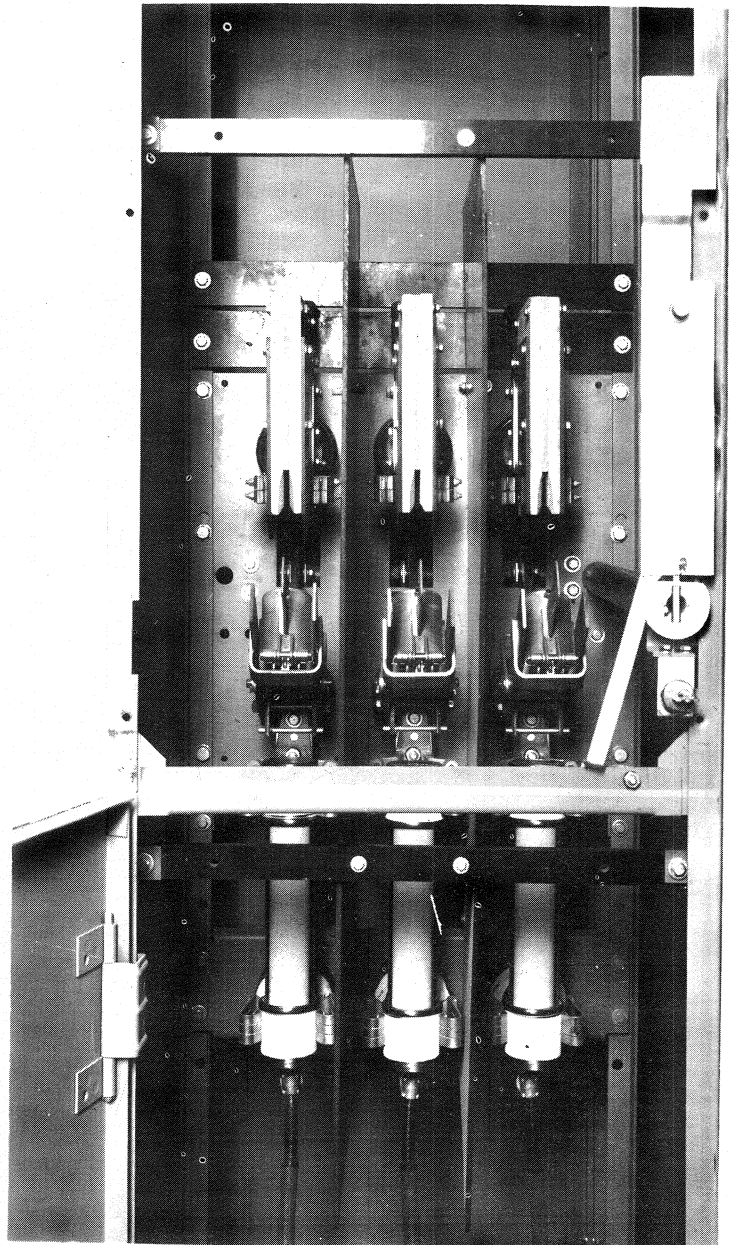

Fig. 2 Front View Of SE-5 Auto-blast Interrupter Switch Mounted In Metal Enclosure

Cover (8007423)

Fig. 1 (8020920)

Fig. 2 (8020919)

AUTO-BLAST INTERRUPTER AND TRANSFER SWITCH

INTRODUCTION

The type SE-5 auto-blast interrupter switch is a manually operated, triple pole device having a dual function. As well as being a disconnecting switch, the SE-5 has the ability to interrupt magnetizing or load currents up to its rating.

The switch is normally furnished in a metal-enclosed housing for connection either directly to the incoming side of a power transformer or to cables by the use of potheads. The operating lever is often interlocked with the secondary circuit breaker in such a manner that the switch cannot be used to interrupt full load current. When applied with power fuses, the combination serves as a successful switching and fault protection device.

The interrupting ability of the switch is accomplished by the use of an arc chute type interrupter

working in conjunction with an auxiliary blade and puffer cylinder. As the switch operates, the arc is forced into the interleaving fins of the arc chute where it is elongated and cooled sufficiently to produce interruption. After the arc has been extinguished, the blade continues to open producing a sufficient air gap to successfully isolate the terminals.

The auto-blast transfer switch is similar in design and operation to the auto-blast interrupter switch. Its use is for those installations having a transfer bus in order to maintain service during shutdowns on the main bus. The transfer switch consists of two independently operated switches interlocked in such a manner as to prevent opening of the main bus until the transfer bus has been energized.

RATINGS

The SE-5 auto-blast switch is available in both a 4.8 KV. and 13.2 KV. frame size. The ratings

for these switches are as shown in the following table:

Type	Nominal Voltage	BIL KV.	Continuous Current	Interrupting Current
Interrupter Switch	4,800	60	600	400
	7,200	95	600	200
	13,200	95	600	100
Transfer Switch	4,800	60	600	600

Table 1

RECEIVING, HANDLING AND STORAGE

RECEIVING AND HANDLING

Immediately upon receipt of the switch, an examination should be made for loss or damage sustained in transit. If injury or rough handling is evident, a damage claim should be filed immediately with the transportation company and the nearest General Electric Apparatus Sales Office should be notified.

Although damage due to handling is minimized because of the metal enclosure, it is expected that due care will be exercised in the unpacking and installation of the switch unit. Care should be taken to prevent tools from striking any part of the housing or the switch itself.

STORAGE

It is recommended that the switch be placed into service immediately in its permanent location.

If this is not possible, the following precautions should be taken to insure proper storage conditions:

1. The switch should be stored in a warm dry location to protect the insulation parts from condensation.
2. The switch should be stored in a clean location free from corrosive gases or fumes. Particular care should be taken to protect the equipment from moisture and cement dust, as this combination has a very corrosive effect on many parts.

If the device is stored for long periods of time, periodic inspections should be made to insure that corrosion of metallic parts or deterioration of insulation parts has not begun. Should the switch be stored under unfavorable conditions, steps should be taken to dry out or replace insulation parts before placing in service.

These instructions do not purport to cover all details or variations in equipment nor to provide for every possible contingency to be met in connection with installation, operation or maintenance. Should further information be desired or should particular problems arise which are not covered sufficiently for the purchaser's purposes, the matter should be referred to the General Electric Company.

INSTALLATION

MOUNTING

The switch must be mounted on a vertical surface with the arc chutes on top. Care should be taken not to distort the base by mounting on an unflat surface as twisting may cause misalignment of the contacts. If necessary, shims should be used to maintain flatness.

CONNECTIONS

Switches are available with either front or back connected terminals or combinations of both. Connection of bus bars to the front-connected terminals can easily be made using the provided bolts. For back-connected switches, the bus bar is connected to the stud using the two nuts. Remove only the outside nut when making this connection. Removal or loosening of the inside nut will cause misalignment of the switch contacts. After connections to the switch have been made, all alignment checks should be made as listed under ADJUSTMENTS.

When furnished as a complete housing, the connections directly to the switch have been made at the factory. On these units, connection is made using the provided potheads and cables.

ADJUSTMENTS

Although the switch has been completely adjusted, operated and inspected at the factory, it is possible that unusually rough handling during transportation may have caused some loosening or disturbance of parts of the apparatus. It is therefore advisable to review all adjustments before placing the switch in service, making readjustments wherever necessary.

All adjustments should be checked not only during the initial installation of the switch, but also during periodic inspections and whenever repair or replacement of parts becomes necessary. The adjustments are listed in the order in which they should be checked.

PRIMARY CONTACT ALIGNMENT

Open and close the switch slowly and observe the position of the primary blades (5), Fig. 3, on each pole as they enter the primary contact fingers (4). The blade should be centrally located within the fingers. To adjust for this, loosen the mounting bolts for either the upper (3) or lower insulator (7) and shift the insulator laterally until correct alignment is obtained. Tighten the mounting bolts and recheck for correct alignment.

PRIMARY CONTACT WIPE

The primary contact finger wipe should be checked using a .002" feeler gauge between the primary blade (5), Fig. 3, and the fingers (4) with the switch in the closed position. Correct wipe is present when each finger has at least 60% contact. To

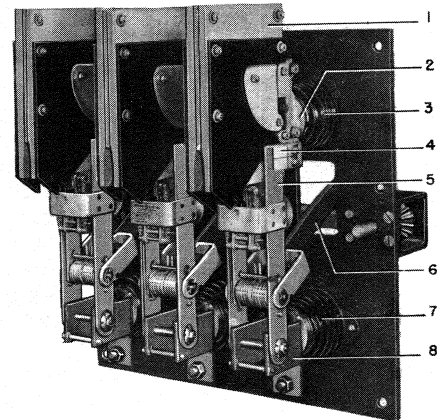

- | | |
|----------------------|--------------------|
| 1. Arc Chute | 5. Primary Blade |
| 2. Contact Block | 6. Operating Link |
| 3. Contact Insulator | 7. Hinge Insulator |
| 4. Primary Fingers | 8. Hinge Block |

Fig. 3 SE-5 Transfer Switch

adjust for correct wipe, loosen the contact insulator (3), Fig. 3, mounting bolts and rotate the insulator slightly in the proper direction.

ARCING CONTACT ALIGNMENT

Open and close the switch slowly and observe the arcing tip (10), Fig. 4, as it enters the arc chute (8). The arcing tip should pass completely through the opening in the arc chute without touching. This adjustment can be made by loosening the arc chute mounting bolts (2) and placing shims on the correct side of the contact block (3). Tighten the mounting bolts and recheck the adjustment. Note: Shifting the arc chute assembly may change the trip roller clearance.

ARCING CONTACT WIPE

With the switch in the latched position, as shown in Fig. 5, there should be electrical contact between the arcing tip (3), Fig. 5, and the arc runner (2). This can be checked using a light indicator or bell set. If contact is not present with the switch in this position, the arcing tip has become sufficiently worn to require replacement.

TRIP ROLLER CLEARANCE

With the breaker in the open position, depress the toggle linkage (7), Fig. 5, as far as possible and slowly close the switch until the roller (6) is directly under the trip latches (5) on the arc chute as shown in Fig. 9. In this position there should be a minimum clearance of 1/16" between the latch

Fig. 3 (8007423)

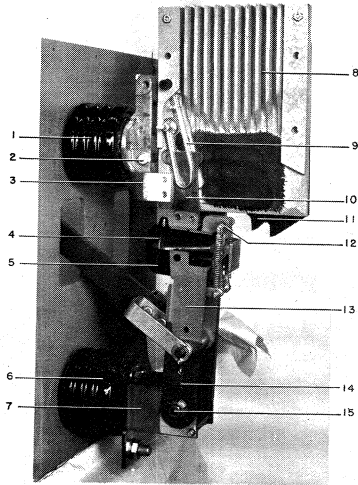

Fig. 4 (8020808)

- | | |
|-----------------------------|---------------------|
| 1. Insulator | 8. Arc Chute |
| 2. Arc Chute Mounting Bolts | 9. Arc Runner |
| 3. Contact Block | 10. Arcing Tip |
| 4. Piston | 11. Trip Latch |
| 5. Puffer Cylinder | 12. Trip Roller |
| 6. Insulator | 13. Auxiliary Blade |
| 7. Hinge Block | 14. Primary Blade |
| | 15. Hinge Stud |

Fig. 4 Cut-away View Of SE-5 Interrupter Switch

and the roller. Also check that all three poles of the switch trip at the same time. This can be checked by opening the switch very slowly until the blades trip. Both the trip roller clearance and the timing can be varied by loosening the arc chute mounting bolts (2), Fig. 4, and sliding the arc chute assembly in the proper direction.

PUFFER CYLINDER PRESSURE

The pressure in the puffer cylinder can be checked by first opening the switch and raising the auxiliary blade to its highest position relative to the primary blade. With the switch in this position, place a finger over the nozzle in the cylinder and release the auxiliary blade assembly. Under this condition the auxiliary blade should remain stationary or move slowly toward its normal position. If the return is rapid, the piston is worn and should be replaced.

PRIMARY FINGER PRESSURE

The pressure of the primary contact fingers can be checked by the use of a small spring balance. With the switch in the open position, place a 3/16" bar between the contact fingers (4), Fig. 3, on each pole and measure the force required to slide the bar from the fingers. The force necessary to do this should be 7 to 9 pounds. A thin film of G.E. type D50H28 lubricant should be applied to the contact fingers before making this measurement. The pressure on the fingers can be varied by loosening

or tightening the bolts holding the fingers in position. NOTE: When adjusting finger pressure, loosen or tighten both the upper and lower bolt. Never loosen the bolts to the point where the fingers are loose when the blade is in the open position.

PRIMARY BLADE HINGE PRESSURE

The pressure at the hinge of the primary blade can be checked by measuring the torque required to rotate the blade assembly. With the blade in a position as to be closed as far as possible without engaging the primary fingers, measure the torque required to rotate the blade towards the open position. The torque should measure 15 to 20 inch-pounds. NOTE: In order to measure this torque, it is first necessary to disconnect the operating link from the operating shaft. Adjustment can be made by loosening or tightening the nuts on the hinge stud (15), Fig. 4.

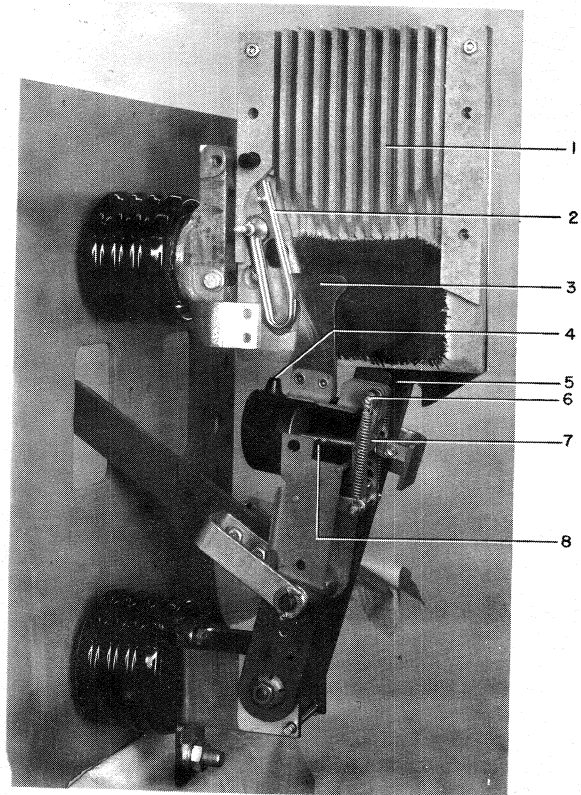
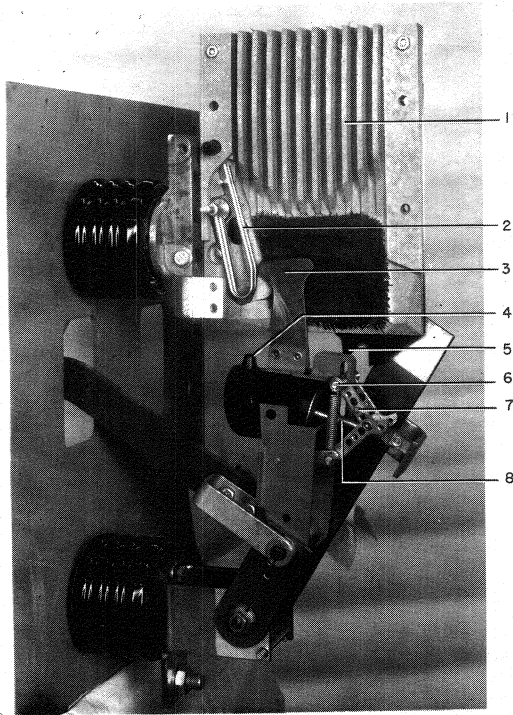

Fig. 5 (8020804)

1. Arc Chute
2. Arc Runner
3. Arcing Tip
4. Nozzle
5. Trip Latch
6. Trip Roller
7. Toggle Link
8. Tripping Pin

Fig. 5 Cut-away View Of SE-5 Switch Shown In Latched Position



1. Arc Chute
2. Arc Runner
3. Arcing Tip
4. Nozzle

Fig. 6 Cut-away View Of SE-5 Switch Shown In Tripped Position

When the switch is in service, it should always be opened or closed with a fast, positive operation. It is recommended that the current in the circuit be checked to insure it is within the rating as listed in Table 1 before opening the switch.

During an opening operation, the blade assembly is rotated towards the open position until the roller (6) engages the trip latch (5) as shown in Fig. 5. As the opening operation is continued, the auxiliary blade remains in contact with the arc runner (2) as the primary contacts part, shunting the current through the arcing tip (3) and auxiliary blade until the pin (8) forces the toggle linkage (7) to collapse as seen in Fig. 6. Once the toggle linkage has tripped, the auxiliary blade is permitted to snap open thereby drawing an arc between the arcing

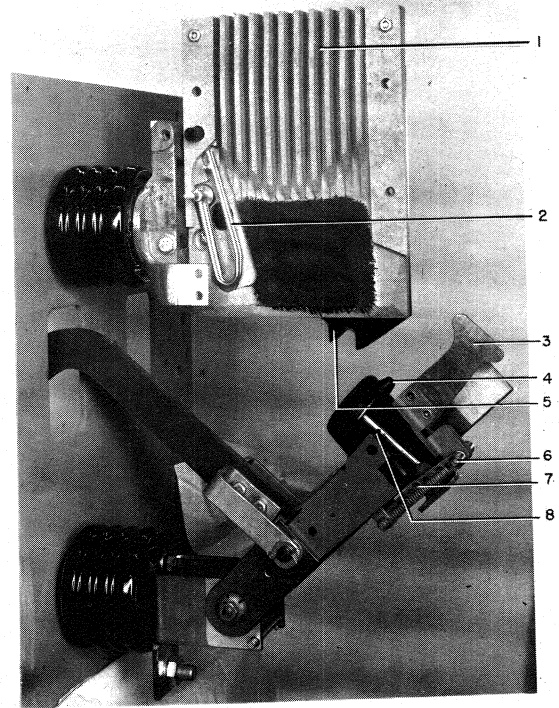

5. Trip Latch
6. Trip Roller
7. Toggle Link
8. Tripping Pin

Fig. 7 Cut-away View Of SE-5 Switch Shown In Nearly Open Position

tip (3) and the arc runner (2). As the auxiliary blade rotates relative to the main blade, a blast of air is directed by the nozzle (4) across the arcing contact forcing the arc into the interleaving fins of the arc chute (1) where interruption is accomplished.

The arc chute furnished with transfer switches incorporates a magnetic blowout coil in series with the arc runner. The blowout coil produces a magnetic field to aid in forcing the arc into the arc chute during the interrupting process.

After the arc has been successfully interrupted, both the main blade and auxiliary blade open sufficiently far to provide complete isolation of the terminals as shown in Fig. 7.

MAINTENANCE

At regular intervals, depending upon service conditions, the switch should be de-energized and solidly grounded for cleaning and inspection. All accessible parts should be wiped with a clean, dry

lintless cloth. The insulators as well as all other blade parts should be examined for damage or excessive wear.

With the switch in the open position, the arcing tip should be examined carefully for smoothness. If rough spots are present due to arcing, they can be smoothed off by the use of a fine file and crocus cloth. NOTE: Do not remove more metal from the tip than is necessary.

Upon completion of the inspection for physical damage, all adjustments and clearances should be checked as listed under ADJUSTMENTS.

LUBRICATION

During the initial installation and at regular maintenance periods, the switch should be checked for proper lubrication. A thin film of G.E. Lubricant D50H28 should be applied to all silvered contact surfaces. Before applying new grease to the contacts, remove any old grease that may be present with a clean, dry cloth. A thin film of D50H28 should also be applied to the contact surface between the main blade and the auxiliary blade. NOTE: Do not apply lubricant to the arcing contacts.

A thin film of G.E. Lubricant D50H15 should be applied to the inner surface of the puffer cylinder. General Electric Lubricants D50H15 and D50H28 are available in 1/4# collapsible tubes.

REPLACEMENT

The following are the detailed assembly instructions for the replacement of those parts that during the life of the switch may require replacement.

NOTE: Upon completion of any assembly work on the switch, all adjustments and clearances must be checked as listed under ADJUSTMENTS, making corrections where necessary.

BLADE ASSEMBLY

To remove the primary blade assembly, proceed as follows:

1. Open the switch.
2. Remove the assembly bolts (6), Fig. 8, from the operating link.
3. Loosen the set screws in the nuts on the hinge stud and remove nuts and spring washers.
4. Remove hinge stud (7), Fig. 8, allowing the complete blade assembly to be removed.

Reassemble in the reverse order checking that set screws are tight after correct hinge pressure is obtained. Refer to the section on LUBRICATION before reassembly. Recheck all blade adjustments.

AUXILIARY BLADE ASSEMBLY

To remove the auxiliary blade assembly, proceed as follows:

1. Open the switch.
2. Remove pin (14), Fig. 9, and release main spring pressure.
3. Remove pin (7) connecting the piston to the primary blade.
4. Remove hinge pin (16) allowing the auxiliary blade to be removed.

Fig. 8 (8007423)

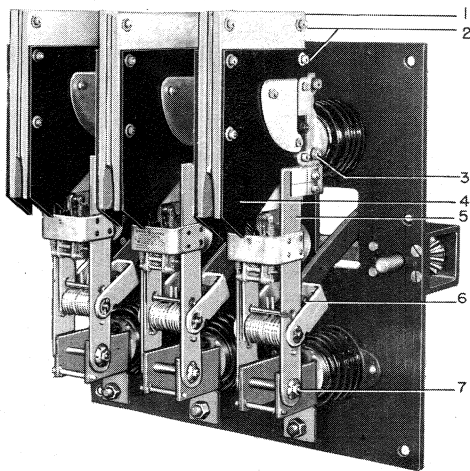

1. Arc Chute Assembly
2. Assembly Bolts
3. Arc Chute Mounting Bolts
4. Side Barrier
5. Main Blade
6. Assembly Bolts
7. Hinge Stud

Fig. 9 (281B770)

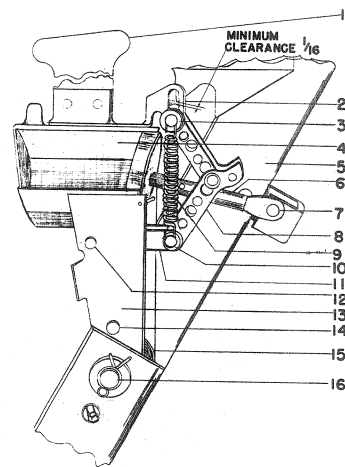

- | | |
|--------------------|---------------------|
| 1. Arcing Tip | 9. Toggle Spring |
| 2. Trip Latch | 10. Pin |
| 3. Trip Roller | 11. Link |
| 4. Puffer Cylinder | 12. Pin |
| 5. Primary Blade | 13. Auxiliary Blade |
| 6. Piston | 14. Pin |
| 7. Pin | 15. Main Spring |
| 8. Toggle Link | 16. Hinge Pin |

Fig. 8 Type SE-5 Auto-blast Transfer Switch

Fig. 9 Cut-away View of Blade Assembly

The same method of disassembly should be followed when removing the auxiliary blade after first removing the complete blade assembly from the switch. Reassemble in the reverse order referring to the section on LUBRICATION. Recheck all adjustments pertaining to the auxiliary blade.

PISTON

To remove the piston, refer to Fig. 9 and proceed as follows:

1. Open the switch.
2. Remove pin (14) releasing the main spring pressure.
3. Remove pin (7) connecting the piston to the primary blade. The auxiliary blade can now be rotated relative to the primary blade towards a vertical position.
4. Remove the two toggle springs (9).
5. Remove the trip rollers (3) and slide the pin from the toggle link.
6. Remove piston.

Reassemble in the reverse order placing a thin film of grease on the inner surface of the cylinder as stated under LUBRICATION. Check for proper air pressure as described under ADJUSTMENTS.

ARCING TIP

To remove the arcing tip (1), Fig. 9, from the auxiliary blade, proceed as follows:

1. Remove the auxiliary blade assembly as previously described.

2. Remove the rivets from the base of the arcing tip. With the rivets removed, the arcing tip can be removed.

A new arcing tip can be installed by re-riveting in place. NOTE: When replacing the arcing tip, it should lean slightly towards the nozzle in the cylinder so that the nozzle is directed at the tip.

PUFFER CYLINDER

To remove the puffer cylinder, the auxiliary blade must first be removed as previously described. The rivets holding the arcing tip in place must also be removed. Under this condition, the legs of the auxiliary blade can be spread for removal of the cylinder. Reassembly can be accomplished by replacement of the arcing tip and the rivets. When replacing the cylinder, apply a thin film of grease as stated under LUBRICATION.

ARC CHUTE ASSEMBLY

The arc chute (1), Fig. 8, can be removed from the switch by removal of the mounting bolts (3). Further disassembly of the arc chute may be accomplished by removal of assembly bolts (2).

When reassembling the arc chute, care should be taken to insure that the fins of the arc chute sides are equally spaced throughout their length. Care should also be taken when bolting the side barriers (4), Fig. 8, in place that the trip latches are opposite each other to obtain proper tripping of the auxiliary blade. After remounting the arc chute, check all adjustments as outlined under ADJUSTMENTS.

RENEWAL PARTS

During the normal life of the switch, no renewal parts should be required. Under certain applications having abnormal operations, some parts may become worn and will require replacement. For these applications, a stock of renewal parts is desirable as it will reduce maintenance shutdown time if worn or damaged parts must be replaced.

The following listing includes all parts used in the SE-5 interrupter and transfer switches, except standard hardware, such as screws, nuts, washers, etc. that can be purchased locally. Included at the end of the listing is a group of parts recommended for normal maintenance.

ORDERING INSTRUCTIONS

When ordering renewal parts, address the nearest General Electric Sales Office, specifying the quantity required, description, catalog and reference numbers, as listed in this bulletin, and complete nameplate data as found on the switch.

Renewal parts which are furnished may not be identical to the original parts, since improvements

are made from time to time. The parts which are furnished, however, will be interchangeable.

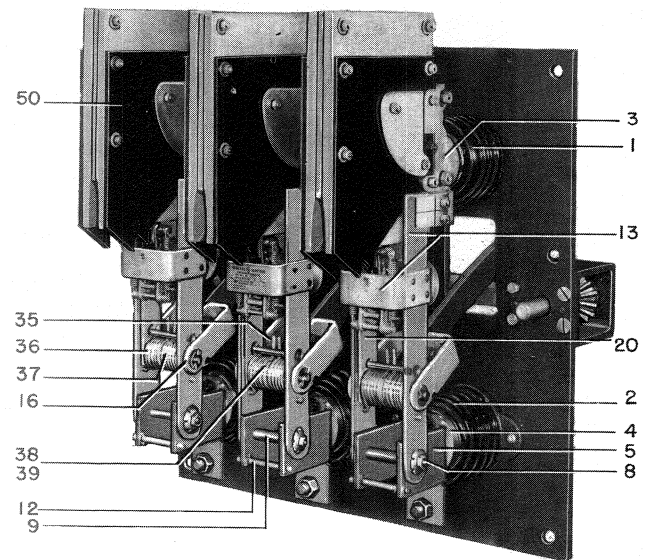

Fig. 10

REF. NO.	CAT. NO.	QT. PER. SW.	DESCRIPTION
1	6314989 G-5	0	Insulator (front connected - 5 KV.)
1	6314989 G-7	0	Insulator (front connected - 15 KV.)
2	6411174 G-1	0	Insulator (back connected - 5 KV.)
2	6411174 G-6	0	Insulator (back connected - 15KV.)
3	6422345 P-2	3	Contact block (front connected, SE-5 and SE-5-1)
3	6422345 P-4	3	Contact block (front connected, SE-5-2 and SE-5-2A)
3	6411838 G-2	3	Contact block (back connected, 5 KV. SE-5 and SE-5-1)
3	263C906 G-7	3	Contact block (back connected, 5 KV. SE-5-2 and SE-5-2A)
3	6411838 G-5	3	Contact block (back connected, 15 KV. SE-5 and SE-5-1)
3	263C906 G-8	3	Contact block (back connected, 15 KV. SE-5-2 and SE-5-2A)
4	6411850 P-1	3	Hinge block
5	263C927 P-30	6	Hinge block spacer (front connected)
5	6411838 G-3	3	Hinge stud (back connected - 5 KV.)
5	6411838 G-6	3	Hinge stud (back connected - 15 KV.)
* 6	6179623 P-9	□	Nut for ref. nos. 3 and 5
* 7	6076572 P-2	△	Washer for ref. no. 6
8	263C904 P-16	3	Hinge stud
9	263C907 P-25	3	Spacer
10	2450821	6	Spring washer
11	6043618	6	Nut
12	6009982 P-7	3	Stop pin
13	263C904 G-2	3	Main blade (right SE-5-2 and SE-5-2A)
13	263C904 G-1	3	Main blade (left SE-5-2 and SE-5-2A)
13	263C904 G-11	3	Main blade (SE-5 and SE-5-1)
14	6244187 P-1	24	Contact finger (SE-5 and SE-5-1)
14	6057288	24	Contact finger (SE-5-2 and SE-5-2A)
15	6227835 P-21	12	Contact finger spring
16	6076405 P-55	3	Hinge Pin (auxiliary blade)
20	263C905 G-1	3	Auxiliary blade asm. (Incl. ref. nos. 21-34)
21	263C905 G-1	3	Arcing tip (SE-5 and SE-5-1)
21	263C907 P-24	3	Arcing tip (SE-5-2 and SE-5-2A)
22	263C905 G-1	3	Cylinder (SE-5 and SE-5-1)
22	281B707 P-1	3	Cylinder (SE-5 and SE-5-2A)
23	6227834 G-2	3	Piston (SE-5 and SE-5-1)
23	263C906 G-3	3	Piston (SE-5-2 and SE-5-2A)

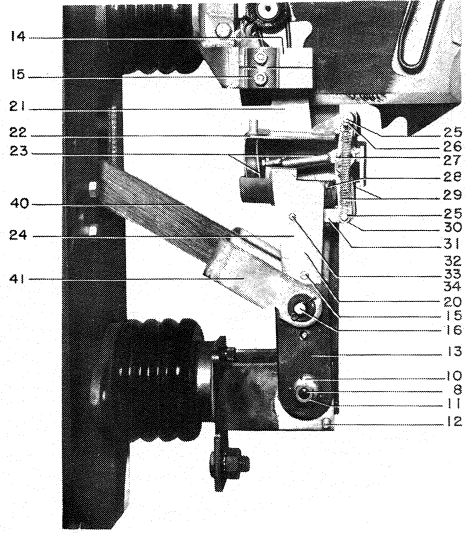

Fig. 11

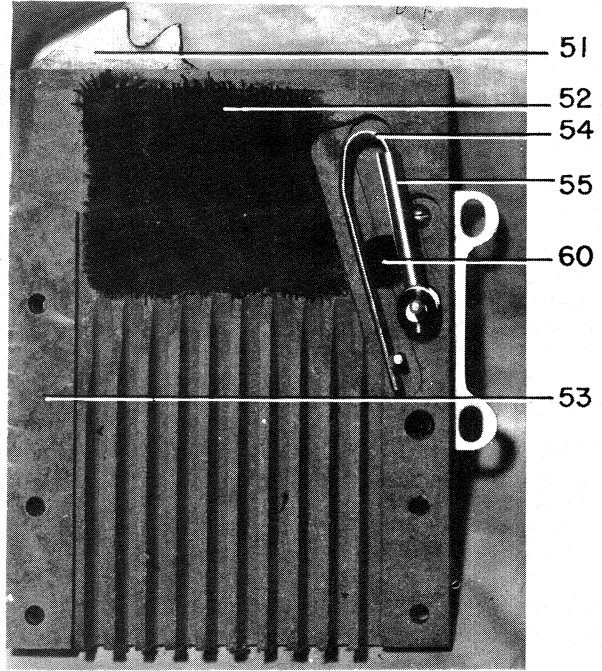

Fig. 12

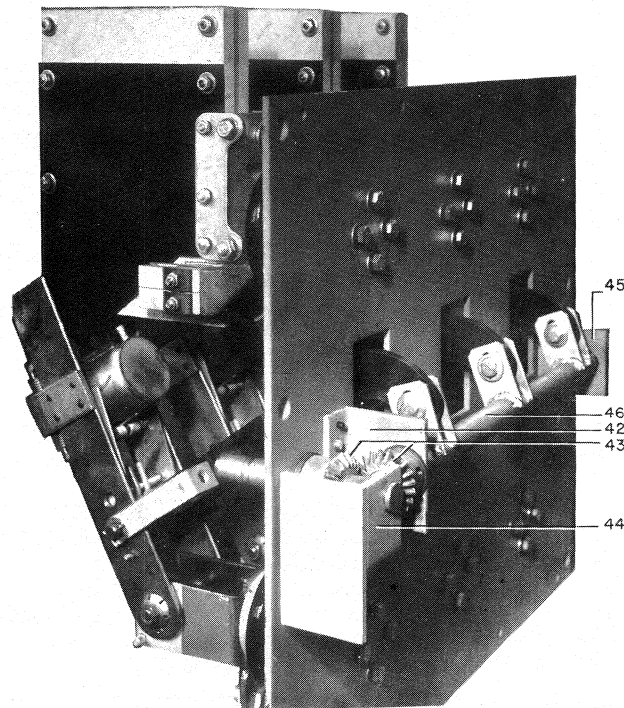

Fig. 13

Fig. 11 (800776)

Fig. 12 (8020654)

Fig. 13 (8020655)

REF. NO.	CAT. NO.	QT. PER SW.	DESCRIPTION
24	263C905 G-1	3	Auxiliary blade (right SE-5 and SE-5-1)
24	263C902 P-1	3	Auxiliary blade (right SE-5-2 and SE-5-2A)
24	263C905 G-1	3	Auxiliary blade (left SE-5 and SE-5-1)
24	263C902 P-2	3	Auxiliary blade (left SE-5-2 and SE-5-2A)
25	6227834 P-4	6	Pin
26	6227835 P-22	6	Roller
27	263C906 G-5	3	Toggle link
28	6227836 P-16	3	Pin (SE-5 and SE-5-1)
28	263C906 P-17	3	Pin (SE-5-2 and SE-5-2A)
29	6202632 P-1	6	Spring for toggle link
30	6176109 P-10	6	Spacer
31	6227835 G-3	3	Guide link (SE-5 and SE-5-1)
31	263C906 G-4	3	Guide link (SE-5-2 and SE-5-2A)
32	6227836 P-15	3	Pin
33	6202639 P-1	3	Spring for guide link
34	6176109 P-11	6	Spacer
35	6227834 P-3	3	Pin
36	6202633 P-1	3	Main spring (left)
37	6202634 P-1	3	Main spring (right)
38	6227836 P-13	6	Bushing
39	6202631 P-1	3	Spring
40	6411871 G-3	3	Operating link (5 KV. - SE-5 and SE-5-2A)
40	263C904 G-7	3	Operating link (5 KV. - SE-5-1 and SE-5-2)
40	6411871 G-4	3	Operating link (15 KV. - SE-5 and SE-5-2A)
40	263C904 G-8	3	Operating link (15 KV. - SE-5-1 and SE-5-2)
41	6411844 P-5	6	Yoke
42	263C907 P-21	1	Support (SE-5-1 and SE-5-2)
43	6446178 P-1	2	Gear
44	6422431 G-4	1	Bearing support (SE-5 and SE-5-2A)
44	263C907 G-8	1	Bearing support (SE-5-1 and SE-5-2)
45	6479355 G-1	1	Support (SE-5 and SE-5-2A)
45	263C907 P-22	1	Support (SE-5-1 and SE-5-2)
46	6411890 G-1	1	Shaft (5 KV. - SE-5 and SE-5-2A)
46	263C907 G-6	1	Shaft (5 KV. - SE-5-1 and SE-5-2)
46	6411870 G-2	1	Shaft (15 KV. - SE-5 and SE-5-2A)
46	263C907 G-7	1	Shaft (15 KV. - SE-5-1 and SE-5-2)
50	6328284 G-1	3	Arc chute asm. (100 and 400 amp. sw. incl. ref. 51-57)
50	6422456 G-1	3	Arc chute asm. (600 amp. sw. incl. ref. 51-61)
51	6227836 P-8	6	Side plate (100 and 400 amp. sw.)
51	6411898 P-1	3	Side plate (right, 600 amp. sw.)
51	6411898 P-2	3	Side plate (left, 600 amp. sw.)
52	6422318 P-3	3	Arc chute side (right)
52	6422318 P-4	3	Arc chute side (left)
53	174V927	3	Spacer
54	6218927 G-1	3	Arc runner contact (100 and 400 amp. sw.)
54	265B845 G-1	3	Arc runner contact (600 amp. sw.)
55	6305182 G-1	6	Flux shield (100 and 400 amp. sw.)
*58	6411899 P-2	6	Pole piece (600 amp. sw.)
*59	6375518 G-1	3	Blowout coil (600 amp. sw.)
*60	6411899 P-4	3	Core (600 amp. sw.)
*61	6446063	3	Core insulation (600 amp. sw.)
56	6227836 P-9	6	Support (100 amp. and 400 amp. sw.)
56	6411899 P-3	6	Support (600 amp. sw.)
57	6328287 P-4	3	Spacer

* Not illustrated

Ø 6 required for switches completely front connected - 3 required for switches both back and front connected - none required for switches completely back connected

∅ 6 required for switches completely back connected - 3 required for switches both back and front connected - none required for switches completely front connected

□ 2 required for each back connected bushing

△ 1 required for each back connected bushing

GEH-2007 Auto-blast Interrupter and Transfer Switch

The following parts are recommended for normal maintenance:

REF. NO.	CAT. NO.	QT. PER SW.	DESCRIPTION
13	263C904 G-2	3	Main blade (Right SE-5-2 and SE-5-2A)
13	263C904 G-1	3	Main blade (Left SE-5-2 and SE-5-2A)
13	263C904 G-11	3	Main blade (SE-5 and SE-5-1)
14	6244187 P-1	24	Contact finger (SE-5 and SE-5-1)
14	6057288	24	Contact finger (SE-5-2 and SE-5-2A)
20	263C905 G-1	3	Auxiliary blade assembly (SE-5 and SE-5-1 only)
50	6328284 G-1	3	Arc chute assembly (100 and 400 amp. sw.)
50	6422456 G-1	3	Arc chute assembly (600 amp. sw.)
21	263C907 P-24	3	Arcing tip (SE-5-2 and SE-5-2A only)
23	263C906 G-3	3	Piston (SE-5-2 and SE-5-2A only)