

INSTRUCTIONS

DS-50 AND DS-60 SERIES POLYPHASE SWITCHBOARD WATTHOUR METERS

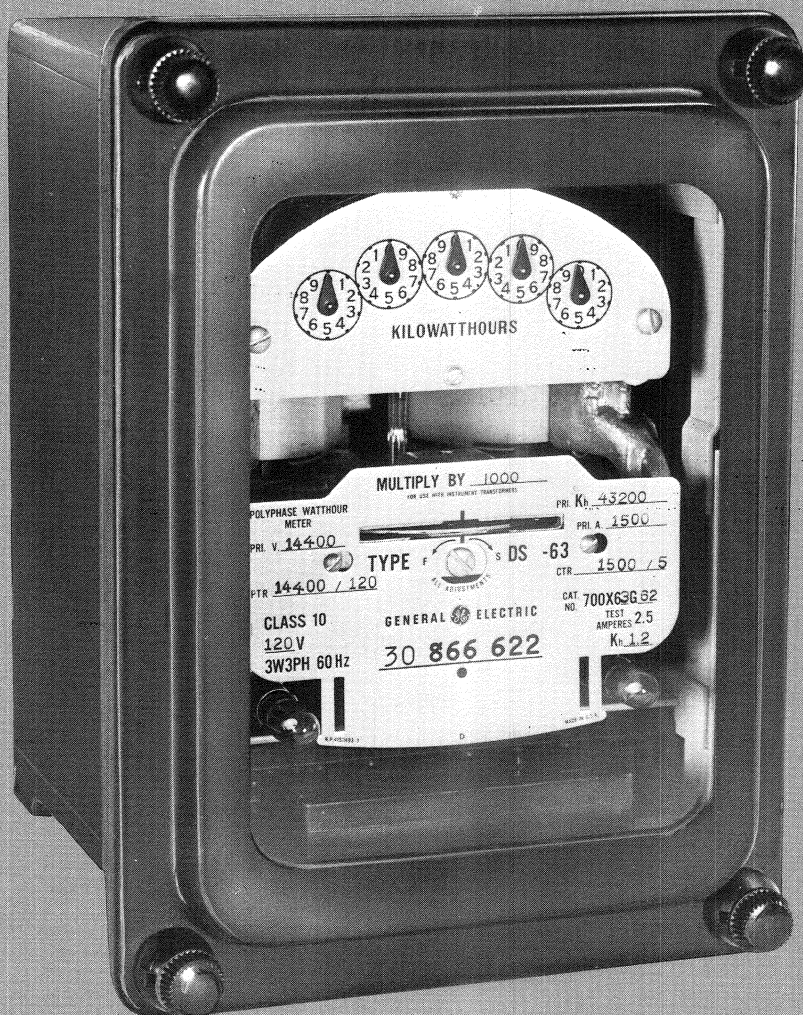

CONTENTS

	Page
INTRODUCTION	3
INSTALLATION	3
SEALING THE METER	4
INSTRUMENT TRANSFORMERS	4
READING THE REGISTER	4
FIGURING REGISTER RATIOS	5
TESTING	5
Watt-hour Constant	6
CALIBRATING ADJUSTMENTS	6
Full Load	6
Light Load	7
Inductive Load (Power Factor)	7
Torque Balance (Phase Balance)	7
MAINTENANCE	7
Magnetic Suspension System (2-stator Meters)	7
Magnetic Suspension System (3- and 4-stator Meters)	8
Mechanical Bearings (3- and 4-stator Meters)	10
Register	11
Stator	11
INSTALLING DEMAND REGISTER	11
PULSE INITIATORS	13
POTENTIAL INDICATING LAMPS	13
DETENT	13
CONNECTIONS	13
LIST OF OTHER PUBLICATIONS	14
CONNECTION DIAGRAMS	15-18
FIELD TESTING CONNECTIONS	19-24
DIMENSION DIAGRAMS	25-28

These instructions do not purport to cover all details or variations in equipment nor to provide for every possible contingency to be met in connection with installation, operation or maintenance. The equipment covered by these operating instructions should be operated and serviced only by competent technicians familiar with good safety practices, and these instructions are written for such personnel and are not intended as a substitute for adequate training and experience in safe procedures for this type of equipment. Should further information be desired or should particular problems arise which are not covered sufficiently for the purchaser's purposes, the matter should be referred to the General Electric Company.

DS-50 AND DS-60 SERIES

POLYPHASE SWITCHBOARD WATTHOUR METERS

INTRODUCTION

These instructions apply to General Electric two-, three- and four-stator, transformer-rated, poly-phase switchboard meters on the following types:

TYPE METER	CIRCUIT APPLICATION	NO. STATORS
DS-53, 63	2-wire; single phase	2
	3-wire network	2
	3-wire; 1-, 2-, or 3-phase	2
DS-54, 64	4-wire Y; 3-phase	3
DS-55, 65	4-wire Y; 3-phase	2
DS-66	4-wire delta; 3-phase	2
DS-67	2-circuit, 3-wire; 3-phase	4
DS-69	2-circuit, 4-wire Y; 3-phase	4

The DS-60 family of meters features a V-frame construction with two stators and a single-disk rotor or three and four stators and a double-disk rotor.

General Electric's DS-50 family of switchboard watthour meters is derived from the DS-60 family design and therefore the meter and meter characteristics are identical, and the size and appearance of the case as well as the provisions for mounting are the same. Basically, the difference is in the provisions for testing the meter. The DS-50 series does not have the built-in test switch facility of the DS-60 line. These DS-50 meters are designed to be used where a separate test switch is desired, or, in some applications, where no test switch is required.

The DS-50 and -60 series meters are rated Classes 10 and 20, and they have full-load nameplate ratings (test amperes) of 2.5 and 5.0, respectively. When used with potential transformers, these meters are rated at 120 volts; however, they are available in ratings up to 600 volts when only current transformers are to be used.

The letter "M" in the type designation denotes a watthour demand meter with mechanical demand register (Type M-30, M-31, M-50 or M-51); for example: DSM-65.

Similarly, the letter "W" in the type designation denotes a watthour meter with a pulse initiator (Type D-20-V, D-30-V, D-41, D-51, D-52, or D-72); for example: DSW-65.

INSTALLATION

DS-60 series meters have drawout construction with a universal case designed for either surface or semi-flush mounting. The case should be mounted and wired permanently before the meter unit is inserted. The meter unit is installed by aligning the cradle with the guides in the case and sliding it into place. The cradle is locked in the case with the top and bottom latches. (See Figs. 5 and 7.) The connecting plug is next inserted, completing the electric circuits through the meter. The cover is then secured to the case with four thumb screws.

The DS-50 types have direct-wired connections between the terminal block and the meter; therefore, they are installed as a unit. These types can be surface or semi-flush mounted the same as the DS-60 meters. All internal wiring has sufficient length to permit a partial withdrawal of the meter from the case for inspection, testing or adjustment. The meter unit is withdrawn by first unlocking the top and bottom latches, then grasping the latches, one in each hand, and carefully pulling out the meter until the top strap prevents any further travel. At this point, the lower part of the meter is moved outward off the bottom skids and lowered into a locked position. The meter is now plumb with the case and may be operated and adjusted. To return the meter to the fully recessed position, grasp the latches, one in each hand, and raise the meter until it can be pushed back into the case. When fully recessed in the case, lock the upper and lower latches and replace the cover.

Both the meter and cradle of the DS-50 types may be entirely removed from the case during installation, servicing, conversion, or maintenance. This is accomplished by removing the two screws that fasten the terminal block to the case. Withdraw both the meter and the terminal block from the case. Depress the strap at the top of the meter so that it disengages the post in the top cover while the meter is withdrawn.

When a meter is mounted semi-flush, the mounting screws are inserted from the back of the panel into threaded bosses on the mounting flange. The

*Revision bars indicate changes included in the current revision.

screws and bosses are hidden from view by the meter cover. Hardware for any type of mounting (semi-flush, surface, metal or insulating panel) and either type of connection (threaded studs with nuts and flat washers, or washer-head screw with prong washer) accompanies each meter. All drilling, wiring, and hammering should be completed on the switchboard before a meter is installed. See Figs. 28 and 30 for 2-stator switchboard drilling and Figs. 29 and 31 for 3- and 4-stator switchboard drilling.

Make the external connections to the case terminals as indicated in the proper diagram included in this manual. See Figs. 9 through 21. (For external connections of contact devices, refer to the instruction book covering the type of device being used.)

All meters are tested before shipment. They require only mounting, connecting, and sealing before being placed in operation. No shipping device is necessary on 2-stator meters.

On 3- and 4-stator meters, a shipping wedge is used to hold the rotor assembly during shipment. Before placing the meter in service, remove the shipping wedge. No adjustment of the bearings is necessary.

SEALING THE METER

The screws that hold the cover in position have knurled heads to permit tightening with the fingers. They are also slotted to take standard types of sealing devices.

INSTRUMENT TRANSFORMERS

Both current and potential transformers have polarity markings of white paint, or markers (H_1 for primary, X_1 for secondary) located on or near one primary and one secondary terminal. These markings denote relative polarity of the winding and indicate that the instantaneous direction of currents in the leads is the same; namely, toward the transformer in the marked primary lead and from the transformer in the secondary lead, or vice versa. The polarity markings are shown in the connection diagrams. In order to obtain the correct direction of rotation of the watthour meter rotor, these markings must be followed, regardless of their physical location on the transformers.

The meter enclosure should be connected to the grounded side of the secondary circuit of each transformer connected to the meter. No. 12 AWG copper wire is adequate for this purpose. At the ground end of the wire the usual precautions employed in

connection with lightning arresters should be followed.

WARNING: UNDER NO CONDITIONS SHOULD THE CURRENT RATED METER BE OPENED WITHOUT FIRST SHORT-CIRCUITING THE SECONDARY WINDING OF THE CURRENT TRANSFORMER.

Removal of the connecting plug in drawout-type DS-60 meters automatically short-circuits the current terminals so that the meter unit can safely be removed from the case.

NOTE: Every circuit in the drawout case has an auxiliary brush. See Fig. 1. It is especially important on current circuits and other circuits with shorting bars that these auxiliary brushes engage the connecting plug or test plug before the main brushes do. This will prevent CT secondary circuits from being opened. Adjust the brushes if necessary.

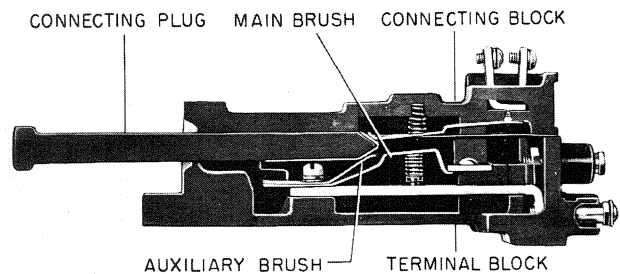

NOTE: AFTER ENGAGING AUXILIARY BRUSH, CONNECTING PLUG TRAVELS 1/4 INCH BEFORE ENGAGING THE MAIN BRUSH ON THE TERMINAL BLOCK.

Fig. 1. Cross section of drawout case showing position of auxiliary brush

READING THE REGISTER

The meters can be supplied with either 4- or 5-dial pointer-type registers or with 4- or 5-digit cyclometer registers. The register can be either "secondary-reading" or "primary-reading".

Secondary-reading registers have high register ratios to read the energy in the transformer secondary circuit; consequently:

1. The actual reading of the secondary-reading register must be multiplied by the proper constant (the ratio of primary energy to secondary energy) to obtain kilowatt-hours in the primary circuit being metered. This constant is normally the product of

the respective ratios of the current and potential transformers used with the meter.

2. Meters with secondary-reading registers can be used with transformers of any ratio without changing registers, since only the multiplier is affected.

Primary-reading registers have register ratios (usually low) to read the energy in the transformer primary circuit; i.e., they allow for the potential and current transformer ratios; consequently:

1. Multipliers are usually in tens; i.e., 1, 10, 100, 1000 or higher.

2. Changing transformer ratios normally requires changing a primary-reading register ratio.

The watthour constant " K_h " marked on the name-plate is for use only in calibrating and checking the meter, and is not to be used in connection with the register reading.

When reading the pointer-type register, the position of each pointer must be determined accurately. In deciding upon the reading of each pointer, the pointer before it (to the right) must be observed. Unless this pointer has reached or passed zero or, in other words, completed a revolution, the pointer to its left has not completed the division upon which it may appear to rest. For this reason, the register can be read most easily and rapidly from right to left, although the recording of its reading is from left to right.

On watthour demand meters, the demand registers may be either the sweep-hand or the cumulative type. Refer to the applicable demand-register instructions (see list on page 14) for reading these registers.

FIGURING REGISTER RATIOS

The register ratio " R_r " is defined as the number of revolutions of the worm gear (which meshes with the rotor shaft) required to produce one revolution of the fastest (right-hand) pointer.

For example, if the register is direct-reading, i.e., has a multiplier of 1, then one revolution of the fastest pointer equals 10 kilowatt-hours. Now determine how many disk revolutions equal 10 kilowatt-hours:

Disk revolutions for one kilowatt-hour =

$$\frac{1000}{K_h} \text{ (watthours per kilowatt-hour)}$$

$$\frac{1000}{K_h} \text{ (watthours per disk rev.)}$$

Disk revolutions for 10 kilowatt-hours =

$$10 \times \frac{1000}{K_h}$$

For example, calculate the register ratio for a 2.5-ampere, 120-volt, DS-63 meter. This meter has a K_h of 1.2 watthours per disk revolution. Therefore,

Disk revolutions for 10 kilowatt-hours =

$$10 \times \frac{1000}{1.2} = 8333 \frac{1}{3}$$

To get the register worm-gear revolutions for 10 kilowatt-hours, divide this figure by the gear reduction between the rotor shaft and the worm gear. This reduction is the number of teeth on the worm gear (100) divided by the pitch of the worm on the rotor shaft (2). Therefore, the first gear reduction is $100/2 = 50$. Dividing the disk revolutions for 10 kilowatt-hours by 50 gives

Worm-gear revolutions for 10 kilowatt-hours =

$$\frac{8333 \frac{1}{3}}{50} = 166 \frac{2}{3}$$

Since this is the number of worm-gear revolutions for one revolution of the first pointer, it is by definition the register ratio, R_r .

Consolidating the above steps,

$$\text{Register Ratio } R_r = \frac{10 \times \frac{1000}{K_h}}{\frac{100}{2}} = \frac{10,000}{50 K_h} = \frac{200}{K_h}$$

The general formula for the register ratio, including the dial-face multiplier, is therefore:

1. For secondary-reading registers:

$$R_r = \frac{200}{K_h} \times \text{dial-face multiplier}$$

2. For primary-reading registers:

$$R_r = \frac{200}{K_h \times \text{CT ratio} \times \text{PT ratio}} \times \text{dial-face multiplier}$$

For further information on register ratios, refer to publication GET-1887.

TESTING

Detailed procedures for testing and adjusting General Electric a-c watthour meters are given in publication GET-813.

The portable watthour-meter standards manufactured by the General Electric Company provide means for making the necessary field tests quickly and accurately, and independent of load variations. Meter testing of the DS-60 series, either in the field or the meter test shop, is facilitated by using test plug Model 12XLA12A1. These connections are shown in Figs. 22 through 27 with the test plug used in place of the meter connecting plug. Refer to Instructions GEI-25372 for further information on test plug Model 12XLA12A1.

All DS-50 series are tested by using an external test switch as described in publication GET-813.

WATTHOUR CONSTANT

The watthour constant " K_h " marked on the nameplate is the number of watthours per revolution of the meter rotor. Two watthour constants are shown; namely, "Test K_h " or " K_h " for use when testing the meter without transformers, and the "Primary Test K_h " or "Primary K_h " as the overall constant for the meter with its transformers.

To improve performance over the extended current and voltage ranges, rotor speed has been reduced to *one-half* that of corresponding older meters. This results in a watthour constant " K_h " twice that previously applicable to a given rating of meter. However, in order that register ratios be consistent

with those already in use, a *double-pitch worm* is used on the rotor shaft so that, for the same rating of meter, the register ratio is unchanged from that used on the older meters.

CALIBRATING ADJUSTMENTS

The following adjustments are provided for calibrating the meters for all load conditions met in normal service. All adjustments increase the meter speed when turned counterclockwise and decrease the speed when turned clockwise, as indicated on the nameplate around the full-load adjustment screw. See Fig. 2.

FULL LOAD

Full-load adjustment is made by turning the micrometer screw shown in Fig. 2. This screw has sufficient range for all normal requirements, including adjustment of a replacement magnet, should this ever be necessary. This adjustment affects the meter calibration equally at all loads and power factors. One turn of the screw will change the calibration approximately 0.3 to 0.4 percent.

CAUTION: DURING THE ADJUSTMENT, CLEANING, OR REPLACEMENT OF A RETARDING MAGNET, IT IS IMPORTANT NOT TO ALLOW ANY MAG-

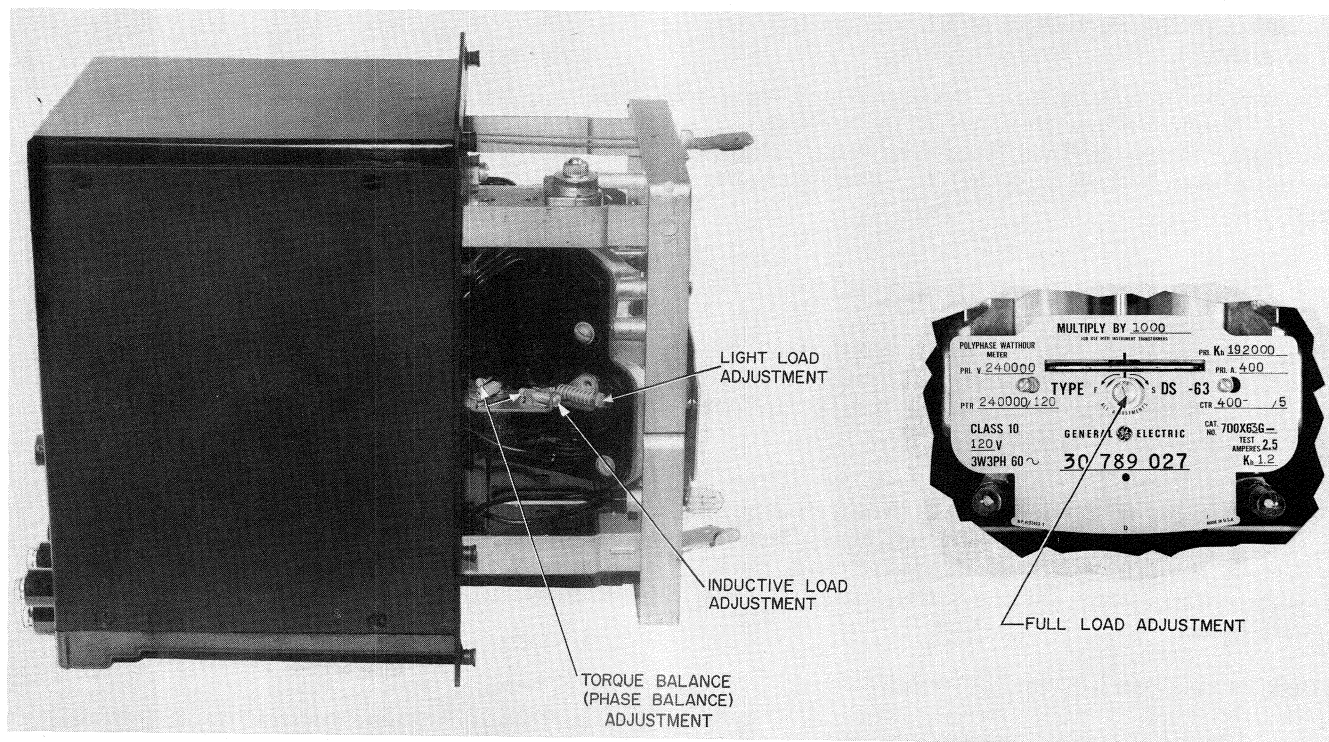

Fig. 2. Location of adjustment screws, DS-50 and DS-60 series meters

NETIC OBJECT, SUCH AS A SCREW-DRIVER BLADE OR MAGNETIC GAP CLEANER, TO COME INTO CONTACT WITH THE MAGNET POLE FACES BECAUSE IT WILL POSSIBLY WEAKEN THE MAGNET.

NOTE: When replacing magnets in the field, check Renewal Parts Bulletin GEF-4139 for correct catalog number designation for meter type.

LIGHT LOAD

Light-load adjustment is made by moving the light-load plate sideways in the air gap of each stator with the adjusting screws provided. See Fig. 2. Since this adjustment introduces a fixed torque of a magnitude depending on the amount the plate is moved, the effect varies inversely with the load torque. For example, a 5.0 percent change at 1/10 rated load current will cause approximately 0.5 percent change in the same direction at rated load 1.0 power factor, and approximately 1.0 percent change at rated load 0.5 power factor. The direction of adjustment is the same as for full load; i.e., counterclockwise to increase speed. Sensitivity of this adjustment is about 0.7 percent per turn when testing one stator at 20 percent rated load, or 1.4 percent per turn when both stators are energized at 10 percent load and both adjusting screws are turned.

NOTE: If the meter under test has a pulse initiator, the light-load check should cover sufficient revolutions (4 to 6) of the rotor to average out variation in friction due to contact position.

INDUCTIVE LOAD (Power Factor)

Inductive-load adjustment is made by moving the lag plate radially with respect to the disk, into or out of the air gap on each stator with the adjusting screw provided. See Fig. 2. The direction of adjustment is the same as for full load; i.e., counterclockwise to increase speed. Sensitivity is approximately 0.5 percent per turn.

Whenever the inductive-load adjustment is changed, both full-load and light-load calibrations should be checked, as they may be affected a small amount.

TORQUE BALANCE (Phase Balance)

All stators in each meter have their torques equalized at the factory by means of the two steel adjusting screws located in the shunt potential flux gaps of each stator. These appear just above the supporting bracket for the lag and light-load plates and are readily accessible from the sides of the meter. See Fig. 2.

If it becomes necessary to make any change in this adjustment, as may be the case when installing a new stator, the two screws of each stator should always be moved exactly the same number of turns and in the same direction. This will prevent excessive shift in light-load calibration. Turning the screws counterclockwise increases the torque (speed) of the stator. Sensitivity is about 0.75 percent per turn of the two screws. After balancing the torques of the stators, the accuracy of the meter should be checked on full load, inductive load, and light load.

MAINTENANCE

MAGNETIC SUSPENSION SYSTEM (2-stator Meters)

No maintenance of the magnetically suspended rotor in the DS-50 and -60 series meters should be required in normal service during the life of the meter. No lubrication is required nor should any be used.

Inspection

With the meter in its normal operating position, inspection can be made as follows (see Fig. 3):

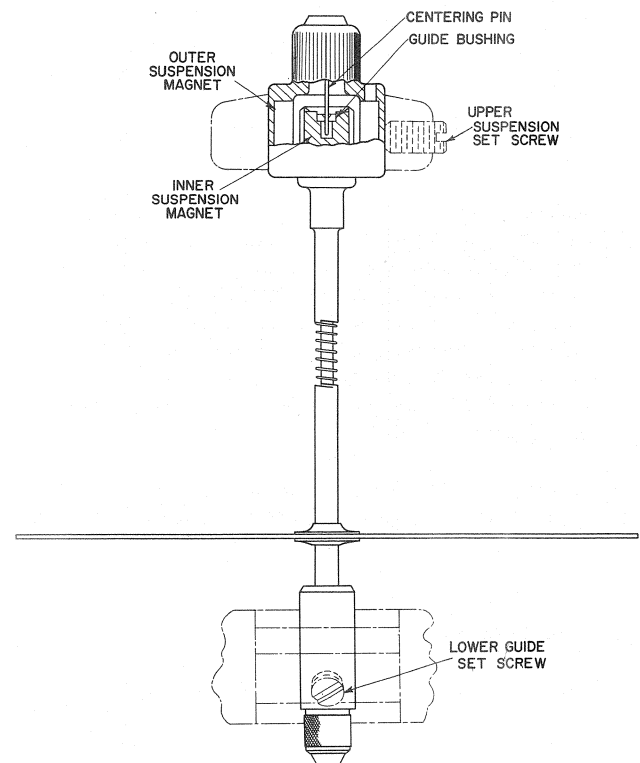

Fig. 3. Magnetic suspension system used on 2-stator meters

1. Raise the rotor until movement is stopped by the centering pin. In this position, the disk should have clearance below the upper pole faces of the retarding magnet. The clearance can be adjusted by moving the outer suspension assembly.

2. Depress the rotor until movement is stopped by the lower guide pin. The disk should move downward 0.005 inch to 0.010 inch and have clearance above the lower pole faces of the retarding magnet. This downward motion and clearance can be adjusted by moving the lower guide assembly.

Removal of Suspension

If it becomes necessary to remove the suspension system, it can be done in the following manner:

1. Remove the register, nameplate, and retarding magnet.

CAUTION: *IN REMOVING THE RETARDING MAGNET, IT IS IMPORTANT NOT TO ALLOW ANY MAGNETIC OBJECT, SUCH AS A SCREWDRIVER BLADE OR MAGNETIC GAP CLEANER, TO COME INTO CONTACT WITH THE MAGNET POLE FACES BECAUSE IT WILL POSSIBLY WEAKEN THE MAGNET. ALSO, KEEP THE MAGNET AWAY FROM MAGNETIC PARTICLES.*

2. Loosen the lower guide setscrew and remove the lower guide.

3. Loosen the upper suspension setscrew and remove the outer suspension assembly.

NOTE: *The outer suspension assembly contains the outer magnet and centering pin. Necessary precautions should be observed in handling to prevent demagnetization of the magnet or damage to the centering pin. Magnetic objects should not touch the magnet. Cleanliness is essential when handling this assembly. Keep it away from magnetic particles.*

4. Remove the rotor. The die-cast section at the top of the shaft contains the inner magnet, so take precautions as described in the Note under step 3 above.

Assembly of Suspension

Assemble the suspension system as follows:

1. Place the meter in the operating position.
2. Inspect the inner magnet for any dirt or magnetic particles. (Use a non-magnetic tool to clean, if necessary.) Insert the rotor in the die-cast frame.

3. Inspect the outer suspension assembly for any dirt or magnetic particles. (Use a non-magnetic tool to clean, if necessary.) Assemble the assembly into the hole at the top of the die-cast frame and enter the rotor into the assembly. The centering pin will be guided into the hole in the bushing by the counter-sink.

4. Finger-tighten the upper suspension setscrew.

5. Inspect the lower guide for any dirt. Insert it into the hole at the bottom of the die-cast frame and enter the centering pin into the bushing in the bottom of the shaft.

6. Finger-tighten the lower guide setscrew.

7. Assemble the retarding magnet.

8. Center the disk in the retarding-magnet air gap by moving the outer suspension assembly. Tighten the upper suspension setscrew.

9. Move the lower guide upward until motion of the disk is noted. Then move the lower guide downward 0.005 inch to 0.010 inch. Tighten the lower guide setscrew.

10. Check the position of the disk in the magnet gap. Refer to the INSPECTION section on page 7.

11. Replace the register and nameplate.

MAGNETIC SUSPENSION SYSTEM (3- and 4-stator Meters)

Three- and four-stator meters with serial numbers 30, 861, 500 and above have a magnetic suspension system consisting of a rotor shaft with two laminated disks, an inner suspension magnet on each end of the shaft, and outer suspension assemblies at each end paired up with the inner magnets. The two pairs of magnets are required to provide the lift necessary to float the rotor assembly. It should be noted that the two outer suspension assemblies are *not interchangeable*, nor are the rotor assemblies interchangeable. For best results they should be used as a complete set as supplied from the factory, consisting of one rotor assembly and the properly color-coded outer suspension assemblies. The upper assembly is color-coded green and the lower one yellow.

No maintenance of the magnetic suspension system should be required in normal service during the life of the meter. No lubrication is required nor should any be used.

Inspection

With the meter in its normal operating position, inspection can be made as follows:

1. The position of each laminated disk should be approximately centered in its respective retarding-magnet gap. Raise the rotor assembly from its float height until movement stops. The assembly should have moved 0.008 inch to 0.015 inch, and there should be clearance between each disk and the upper pole faces of both retarding magnets as well as all potential-coil poles and current-coil poles on all stators.

2. Allow the rotor assembly to return to its normal float height and then depress it until movement stops. It should have again moved 0.008 inch to 0.015 inch, and there should be clearance between each disk and the lower pole faces of both retarding magnets as well as all potential-coil poles and all current-coil poles on all stators.

If the above conditions are not met, the suspension system should be reset. First, determine whether both disks are centered in the retarding magnet gaps. If not, check to see if foreign matter such as lint, chips, hair, etc., are causing the difficulty. Next, rotate the rotor assembly to make sure that any slight wobble in the laminated disk assemblies is not causing the appearance of an off-center condition. If not, and if only one disk is not centered, loosen the setscrew in the hub and reposition the disk.

CAUTION: BE SURE THAT THE ANTI-CREEP HOLE IN EACH DISK IS 180 DEGREES APART WITH RESPECT TO EACH OTHER.

If the disks are properly centered, but incorrect up-and-down travel is at fault, or if both disks are off-center approximately the same amount, correction can be made by moving the outer suspension assemblies. For example, if insufficient down-travel is the problem, *slight* movement of the lower assembly downward, as well as *slight* movement of the upper assembly upward, will correct the problem. It should be noted that corrections of down-travel, up-travel, or the off-center condition of both disks require that *both* outer suspension assemblies be moved.

Removal of Suspension

If it becomes necessary to remove the suspension system, it can be done in the following manner:

1. Remove the register, nameplate, and retarding magnets.

CAUTION: IN REMOVING THE RETARDING MAGNETS, IT IS IMPORTANT NOT TO ALLOW ANY MAGNETIC OBJECT, SUCH AS A SCREWDRIVER BLADE OR MAGNETIC GAP CLEANER, TO COME INTO CONTACT WITH THE MAGNET POLE FACES BECAUSE IT WILL POSSIBLY WEAKEN THE MAGNETS. ALSO, KEEP THE MAGNETS AWAY FROM MAGNETIC PARTICLES.

2. Loosen the upper and lower suspension setscrews and remove the outer suspension assemblies.

NOTE: Each outer suspension assembly contains an outer magnet and centering pin. Necessary precautions should be observed in handling to prevent demagnetization of the magnet or damage to the centering pin. Magnetic objects should not touch the magnet. Cleanliness is essential when handling this assembly. Keep it away from magnetic particles.

3. Remove the rotor assembly. The die-cast section at each end of the shaft contains the inner magnets, so take precautions as described in the Note under step 2 above.

Assembly of Suspension

Assemble the suspension system as follows:

1. Place the meter in the operating position.

2. Inspect the inner magnets for any dirt or magnetic particles. (Use a non-magnetic tool to clean, if necessary.) Insert the rotor assembly into the die-cast frame and hold it in place by hand.

3. Assemble the upper retarding magnet, then assemble the lower retarding magnet.

4. Inspect the two outer suspension assemblies for any dirt or magnetic particles. (Use a non-magnetic tool to clean, if necessary.) Insert the two outer suspension assemblies into the holes at the top and bottom of the die-cast frame. (Be sure that the assembly inserted at the top is color-coded green and the one at the bottom is color-coded yellow.) Enter each end of the rotor shaft into the suspension assemblies.

5. While holding both outer suspension assemblies, move the suspension system sufficiently so that the two disks are visually centered in the retarding-magnet air gaps.

6. Lightly tighten the lower suspension setscrew. Again move the upper suspension assembly so that

the disks are centered, then lightly tighten the upper suspension setscrew.

7. Make the final adjustment of the suspension system. Refer to INSPECTION section on page 9.

8. Replace the register and nameplate.

**MECHANICAL BEARINGS
(3- and 4-stator Meters)**

Three- and four-stator meters with serial numbers below 30,861,500 have mechanical bearings to support the rotor assembly. These bearings are described below.

Enclosed-type Ball Bearing (Lower Bearing)

The enclosed-type ball bearing consists of a ball held between an upper and a lower jewel, the whole being enclosed in a protective sleeve, as shown in Fig. 4.

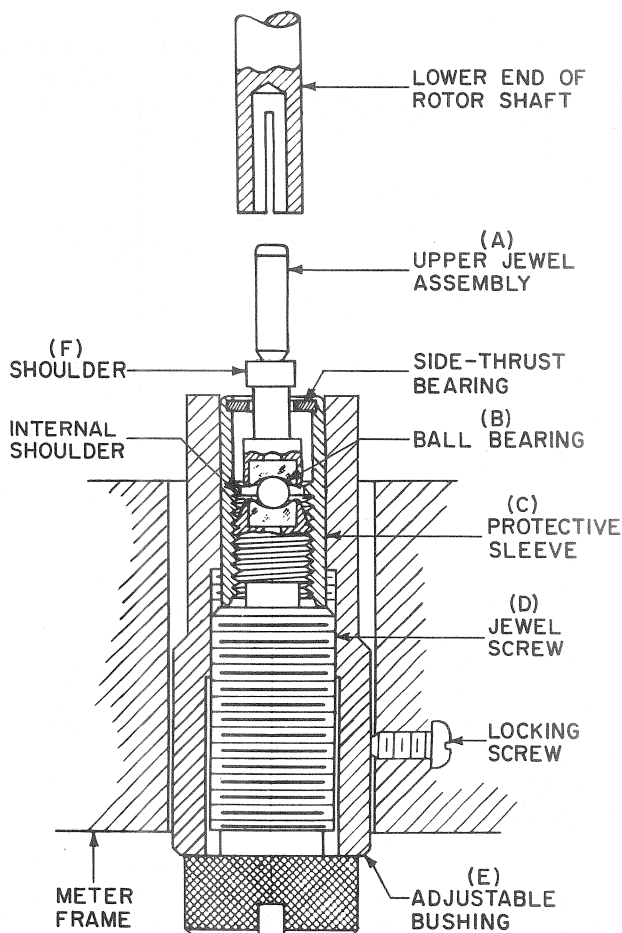

Fig. 4. Enclosed-type ball bearing used on 3- and 4-stator meters below serial number 30,861,500

LUBRICATION

No lubrication is necessary with this type of meter bearing.

REPLACEMENT

At each test period the bearing should be disassembled and the jewels cleaned and inspected for worn spots.

The following procedure, with reference to Fig. 4, is recommended for replacement of an enclosed-type ball bearing.

1. Remove the jewel-screw assembly by inserting a screwdriver into the slot in the lower jewel screw (d) and backing out the screw. When the lower jewel screw (d) has been backed out, the section (a) will still be engaged in the split shaft or adapter. A pull is required to disengage it before the assembly can be removed. The force exerted need not be sufficient to bend the rotor disk. To remove the upper jewel assembly (a) and ball bearing (b) from the jewel-screw assembly, unscrew protective sleeve (c) with a pair of pliers.

The assembly of the bearing is readily accomplished by following the instructions in steps 2 through 4 below.

2. Hold the sleeve (c) in one hand with the threaded end up and drop the upper jewel assembly (a) into the sleeve, making sure that the shoulder (f) is pulled through the small hole in the sleeve until it appears, as shown in Fig. 4.

3. Drop the ball into the sleeve (c), and it will then rest in the jewel cup of (a).

4. Screw in the lower jewel screw (d) and make sure that the sleeve (c) is tightened down firmly.

The assembly of the complete bearing in the watthour meter and the setting of the top bearing can be made as outlined below.

5. Screw the lower jewel screw (d) into the adjustable guide bushing (e), being careful to see that the upper jewel assembly (a) engages the hole in the adapter or the hole in the end of the split shaft.

6. Loosen the top-bearing clamping screw and drop the bearing until it rests on the top of the shaft. Hold a finger on the top bearing.

7. Screw the lower jewel screw (d) into the guide bushing (e) until the shoulder (f) is snug up against either the adapter or the end of the split shaft.

CAUTION: TOO MUCH PRESSURE MAY DAMAGE THE ADAPTER OR THE SHAFT. FOR THAT REASON IT IS SUGGESTED THAT THE TOP-BEARING CLAMPING SCREW NOT BE TIGHTENED, BUT THAT THE PRESSURE OF A FINGER ON THE TOP BEARING BE USED TO PUSH THE UPPER JEWEL ASSEMBLY (a) INTO THE ADAPTER OR SPLIT SHAFT UNTIL THE SHOULDER (f) IS SNUG UP AGAINST THE END OF THE ADAPTER OR SHAFT.

8. Should the rotor disk need adjusting for proper clearance in the retarding-magnet air gap, such adjustment can be accomplished by loosening the clamping screw of the guide bushing (e) and moving the guide bushing and jewel-screw assembly up or down, as desired.

9. Adjust the top bearing by positioning it 0.020 inch to 0.030 inch maximum above the top of the rotor shaft. Then tighten the clamping screw. Check the setting by measuring the up-travel of the rotor.

10. Always check the calibration of the meter if the bearings have been replaced or if the position of the meter rotor has been changed in the magnet air gap.

Upper Bearing

The upper bearing consists of a guide pin mounted in an adjustable top bearing, and a guide bushing set into the tip of the rotor shaft.

The top bearing assembly is supplied with lubricant at the factory, and should require no attention during the normal life of the meter.

If adjustment or replacement of the top bearing is necessary, reset by positioning it 0.020 inch to 0.030 inch maximum above the top of the rotor shaft. Then tighten the clamping screw. Check the setting by measuring the up-travel of the rotor.

REGISTER

The register dial face can be cleaned with a damp cloth.

When replacing a register, be sure that the new register has the same register ratio. Carefully inspect the mesh of its worm gear with the worm on the rotor shaft to see that it is approximately 1/3 to 2/3 the depth of tooth on the register worm gear. A means for adjustment is provided in the eccentric adjusting screw in the bracket on the back of the register. Avoid meshing too deeply, which might cause friction and affect the accuracy of the meter.

The use of oil on the register bearings is not recommended.

For proper care of demand registers, refer to their respective instructions. See the list of publications on page 14.

STATOR

If a potential or current coil is damaged, the entire stator should be replaced.

INSTALLING DEMAND REGISTER

Conversion of DS-50 and DS-60 series watthour meters to accept a Type M-30, M-31, M-50 or M-51 demand register can be accomplished by moving the meter unit approximately 1-1/2 inches toward the back of the case. The changeover is made as follows:

A. To convert 2-stator meters:

1. Remove the cover and slide the cradle out of the meter case. In the DS-50 series, the two screws holding the terminal block to the case must be removed. To completely remove the meter unit from its case, depress the safety latch (see Fig. 5) enough to clear the stop post.

2. Remove the watthour register, nameplate, and two potential-indicating-lamp assemblies.

3. For the DS-60 series, remove the two contact-block mounting screws and pull the contact block away from its cradle mounting until the lower frame-mounting screw is accessible.

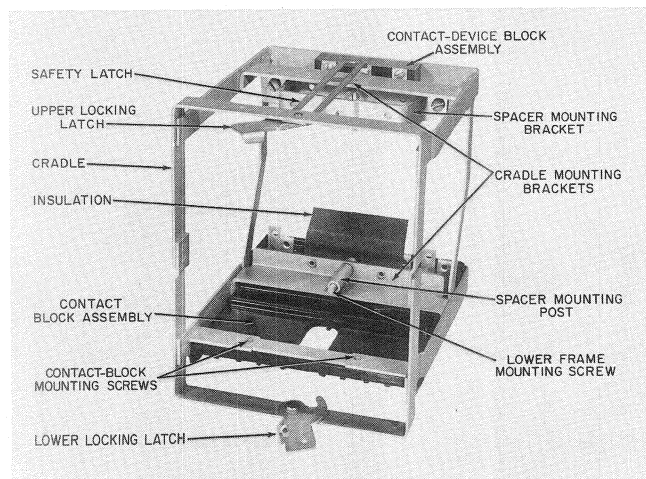

Fig. 5. Cradle for 2-stator meters with assembly removed

4. Remove the three frame-mounting screws, spacer mounting post, two spacer mounting-bracket screws, and spacer mounting bracket. Move back the meter in the cradle and position the lower frame-mounting boss *behind* the lower cradle-mounting bracket and the upper frame-mounting bosses *in front* on the upper cradle-mounting bracket.

Use one of the spacer mounting-bracket screws to secure the frame to the lower cradle-mounting bracket and the two short frame-mounting screws to secure the frame to the upper mounting bracket.

On DS-50 series meters assemble the terminal block to the case with two terminal-block mounting screws.

5. Reposition the contact block onto the cradle and assemble the two mounting screws where applicable.

6. Add the demand-register mounting studs, demand register, potential-indicating-lamp assemblies, and new nameplate. To make connections refer to separate instructions covering the demand register.

7. Adjust the mesh (see REGISTER section, page 11). Check the meter calibration and adjust if necessary.

NOTE: Demand registers require a motor shield when used on meters having magnetic suspension. Before installing Type M-30 and M-31 demand registers with serial numbers below 1653204 upon a meter, it is necessary to remove the motor shield and replace it with a shield of later design. This change in the shield design (see arrow in Fig. 6) eliminates mechanical interference between the register and the meter.

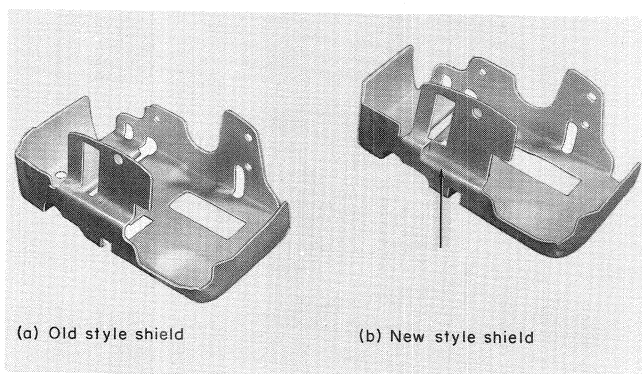

Fig. 6. Motor shield for demand registers

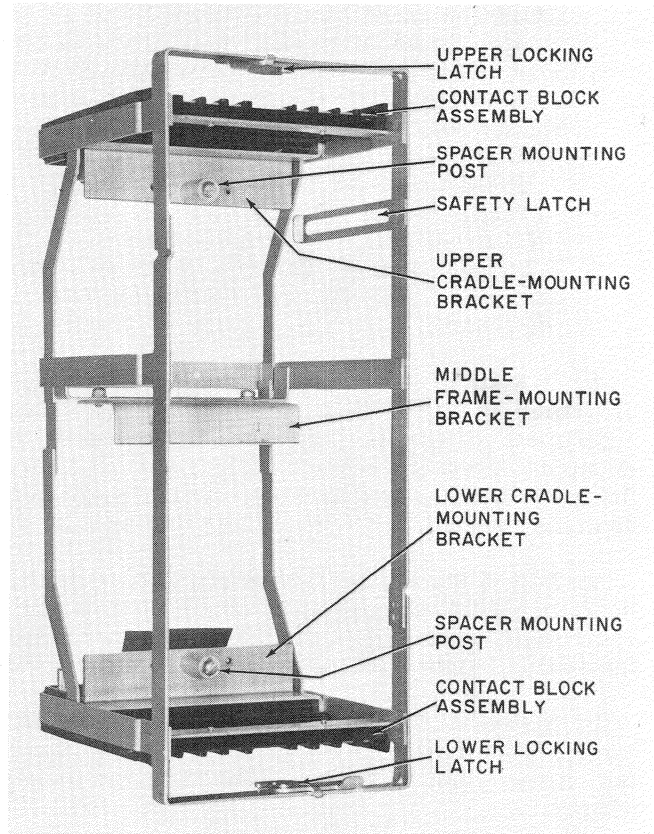

Fig. 7. Cradle for 3- and 4-stator meters with assembly removed

B. To convert 3- and 4-stator meters:

1. Remove the cover and slide the cradle out of the meter case. On the DS-54 meter, the two screws holding the terminal block to the case must be removed. To completely remove the meter unit from its case, depress the safety latch (see Fig. 7) to clear the case stop.

2. Remove the watthour register and nameplate.

3. Remove the four frame-mounting screws, the middle frame-mounting bracket and two spacer mounting posts.

4. Rotate the frame parallel to the back of the cradle until the upper and lower frame-mounting boss can be located behind the upper and lower cradle-mounting bracket. Assemble the upper and lower frame-mounting screws (supplied in the conversion kit) but do not tighten. Assemble the shallower middle frame-mounting bracket to the cradle and frame, using the original screws. Then tighten all screws. On the DS-54 meter, assemble the terminal block to the case with two terminal-block mounting screws.

5. Add the demand-register mounting studs, the demand register and the new nameplate. To make connections, refer to separate instructions covering the demand register.

6. Adjust the mesh (see REGISTER section, page 11). Check the meter calibration and adjust if necessary.

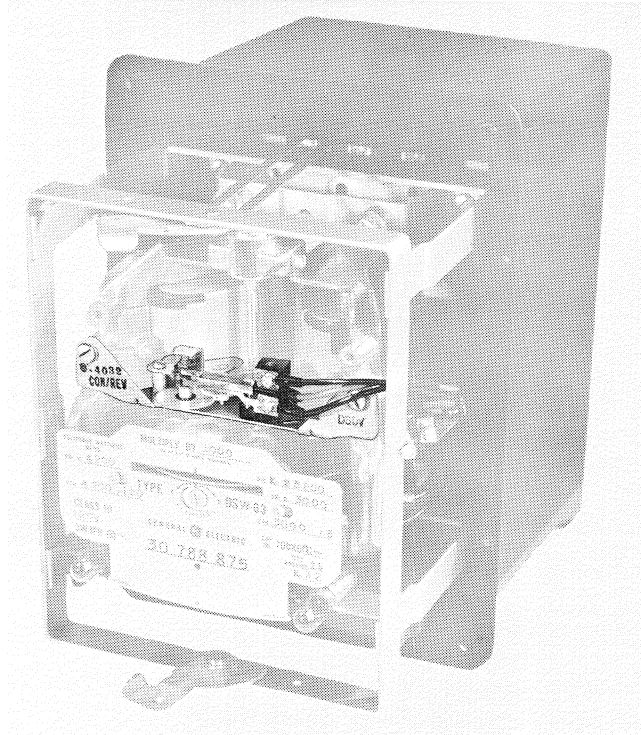

Fig. 8. Type D-30-V pulse initiator mounted on a Type DSW-63 meter

PULSE INITIATORS

Pulse initiators for DSW-50 and DSW-60 series meters are mounted on the front of the meter frame, just below the register. A separate pair of mounting holes is provided for this purpose. See Fig. 8. The spur drive gear on the pulse initiator meshes with a spur pinion hobbled into the rotor shaft.

Six types of pulse initiators may be used on DSW-50 and DSW-60 series meters:

- | | |
|-----------|--|
| 1. D-20-V | 2-wire, low pulse rate. |
| 2. D-30-V | 3-wire, low pulse rate. |
| 3. D-41 | 3-wire pulse initiator (with auxiliary amplifier) with very high pulse rate. |

- | | |
|-------------------------|--|
| 4. D-51, D-52, and D-72 | 3-wire pulse initiators with very high pulse rate. |
|-------------------------|--|

CAUTION: WHEN THE TYPE D-41, D-51, D-52 OR D-72 IS USED, COLOR CODING MUST BE CAREFULLY FOLLOWED ON THE K (RED), Y (YELLOW), AND Z (BLACK) LEADS, SINCE THE Y AND Z LEADS HAVE DIFFERENT VOLTAGE LEVELS. ON THE D-41, DO NOT APPLY HI-POT VOLTAGE TO KYZ TERMINALS OR THE SOLID-STATE COMPONENTS MAY BE DAMAGED. ON TYPES D-51, D-52 AND D-72, DO NOT APPLY HI-POT VOLTAGE TO KYZ TERMINALS. IF THE TRANSFORMER IS HI-POTTED, DO NOT EXCEED 1500 VOLTS.

For separate instructions covering wiring and installation of pulse initiators, refer to the list of publications on page 14.

All meters ordered with pulse initiators, or for use with a pulse initiator, have, in addition to the pinion on the rotor shaft, three pulse initiator leads and terminals, so that either a 2-wire or 3-wire pulse initiator can be used.

POTENTIAL INDICATING LAMPS

All meters are furnished with potential indicating lamps. These are connected to isolated secondary windings on the potential coil cores, so that they give a positive indication of the presence of potential magnetic flux in the stator core.

DETENT

For applications in which reverse rotation of the meter must be prevented, a detent is available. For detailed installation instructions, refer to Instructions GEH-2763.

CONNECTIONS

The connection diagrams in this book (Figs. 9 through 21) show approved methods of wiring these meters. Other methods are possible which are electrically equivalent and which, for particular installations, may result in more convenient or economical wiring. If the meter is properly connected in the circuit, the disk will rotate counter-clockwise, as viewed from above.

LIST OF OTHER PUBLICATIONS

(Order from Distribution Services, General Electric Co., Schenectady, N.Y. 12345.)

Instruction Books:

Type M-30 Demand Register	GEH-1529
Type M-31 Demand Register	GEH-1451
Type M-50 Demand Register	GEH-2785
Type M-51 Demand Register	GEH-2783
Types D-20 and D-30 Pulse Initiators	GEH-2754
Type D-41 Pulse Initiator	GEH-2767
Type D-51 Pulse Initiator	GEH-2781
Types D-52 and D-72 Pulse Initiators	GEH-2786
Installation of Detent Assembly	GEH-2763
Test Plug, Model 12XLA12A1	GEI-25372

Renewal Parts Bulletins:

Types M-30 and M-31 Demand Registers	GEF-3594
Type M-50 Demand Register	GEF-4385
Type M-51 Demand Register	GEF-4372
DS-50 and DS-60 Series Meters	GEF-4139
Types D-20, D-30, and D-41 Pulse Initiators	GEF-4091
Type D-51 Pulse Initiator	GEF-4344
Types D-52 and D-72 Pulse Initiators	GEF-4386

How to Test and Adjust GE Watthour Meters	GET-813
Constant and Register Ratio Data	GET-1887
How to Select Pulse Initiators	GET-3048

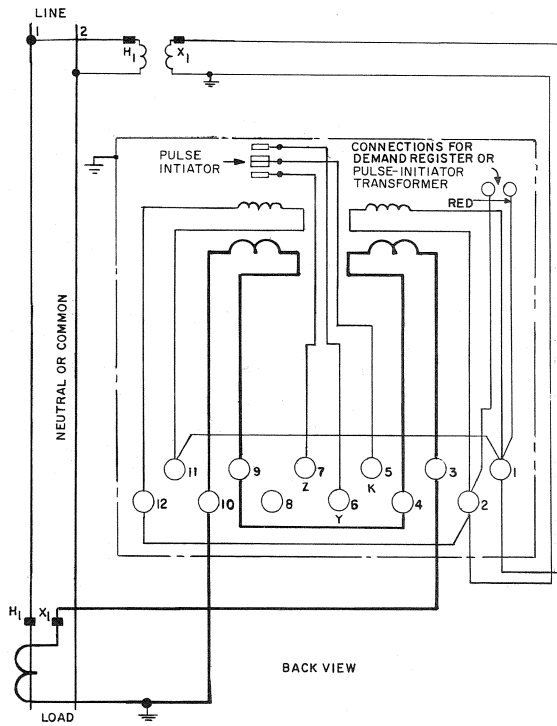

Fig. 9. Connections for Types DS-53, DSM-53, and DSW-53 meters, 2-wire single-phase, with potential and current transformers

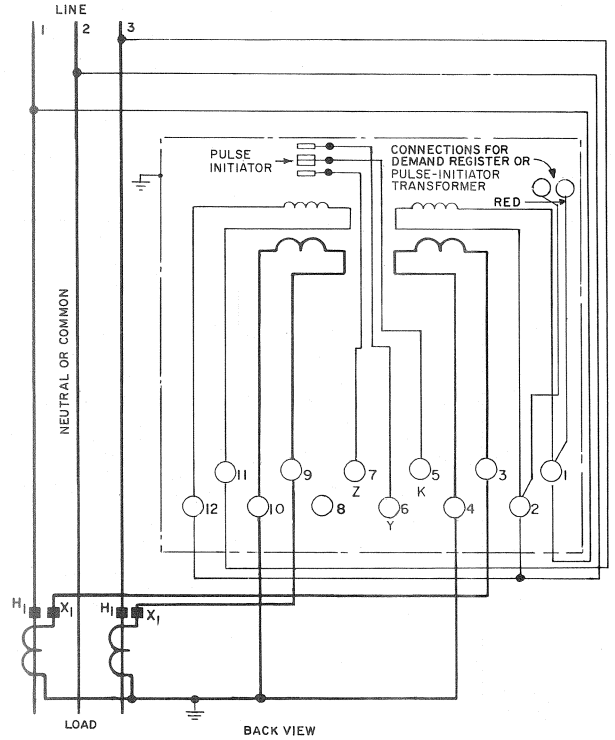

Fig. 10. Connections for Types DS-53, DSM-53, and DSW-53 meters, 3-wire single-phase, 3-wire 2-phase, or 3-wire network, with current transformers

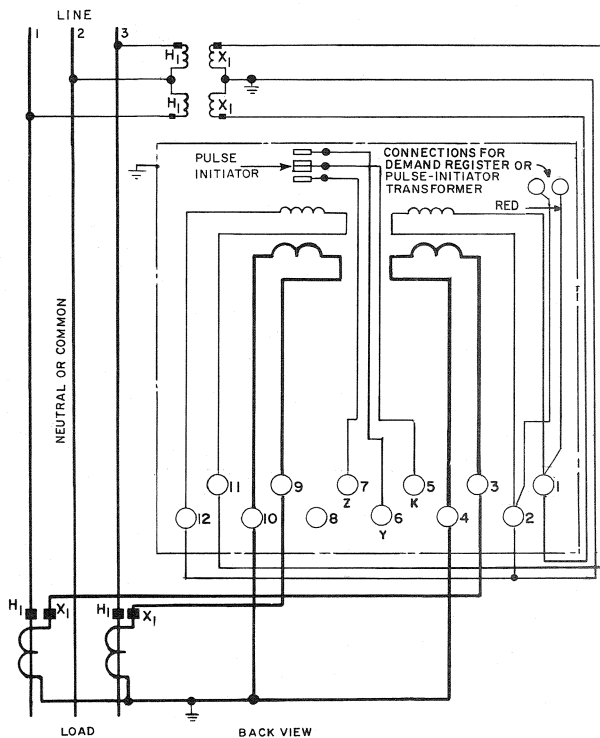

Fig. 11. Connections for Types DS-53, DSM-53, and DSW-53 meters, 3-wire 3-phase, with potential and current transformers

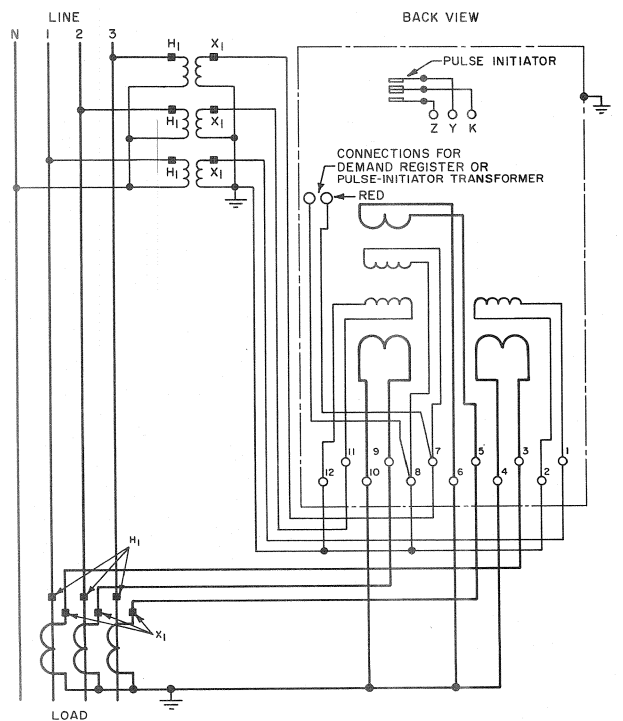

Fig. 12. Connections for Types DS-54, DSM-54, and DSW-54 meters with potential and current transformers

GEH-2762C, DS-50 and DS-60 Series Polyphase Switchboard Watthour Meters

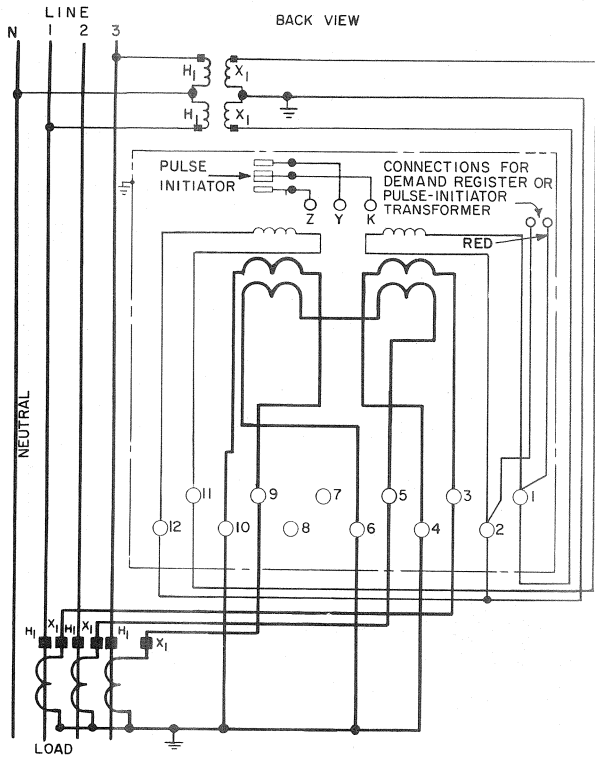

Fig. 13. Connections for Types DS-55, DSM-55, and DSW-55 meters with potential and current transformers

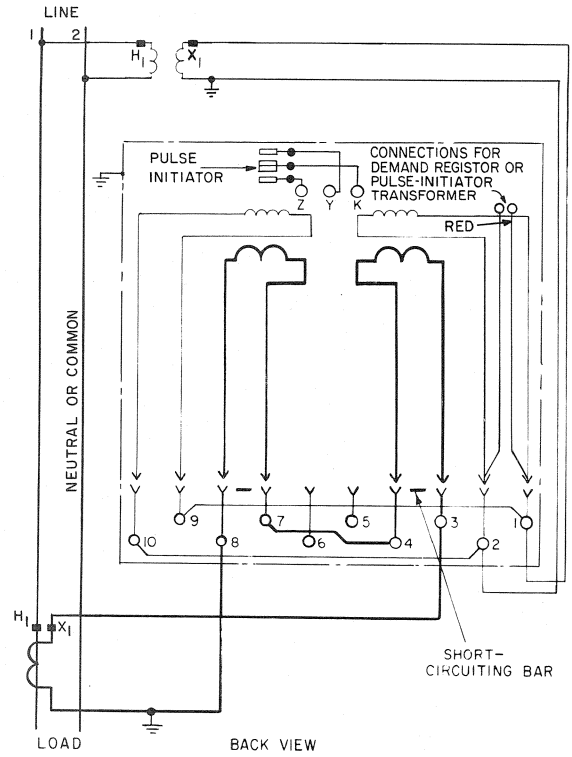

Fig. 14. Connections for Types DS-63, DSM-63, and DSW-63 meters, 2-wire single-phase, with potential and current transformers

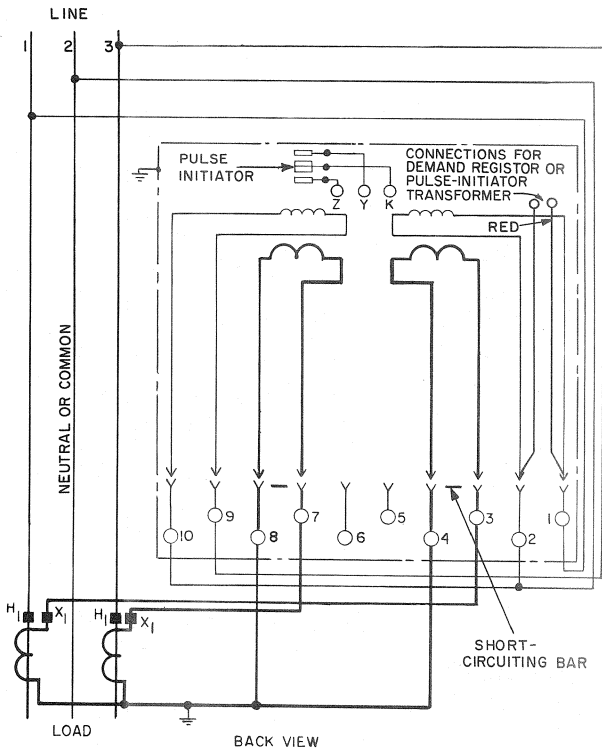

Fig. 15. Connections for Types DS-63, DSM-63, and DSW-63 meters, 3-wire single-phase, 3-wire 2-phase, or 3-wire network, with current transformers

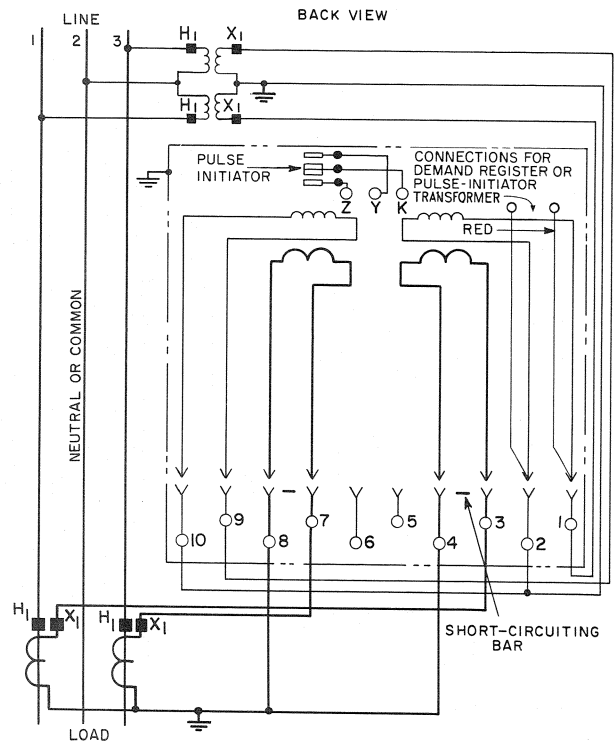

Fig. 16. Connections for Types DS-63, DSM-63, and DSW-63 meters, 3-wire 3-phase, with potential and current transformers

DS-50 and DS-60 Series Polyphase Switchboard Watthour Meters, GEH-2762C

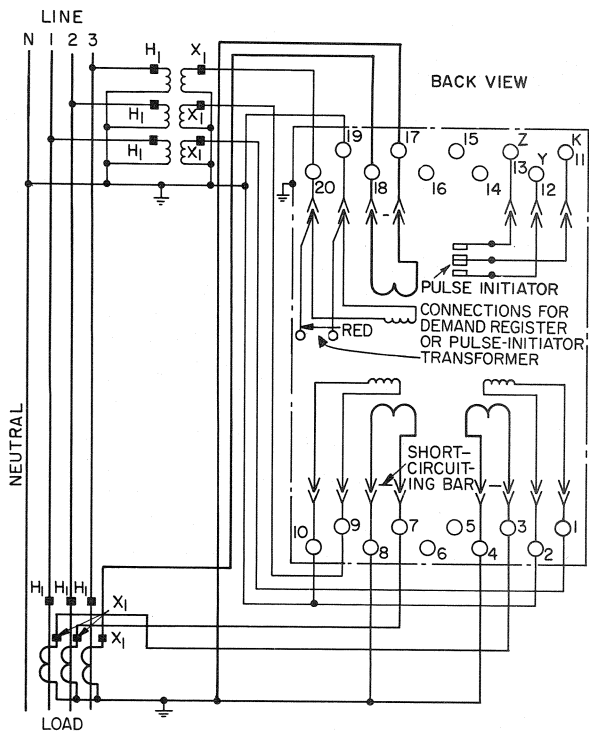

Fig. 17. Connections for Types DS-64, DSM-64, and DSW-64 meters with potential and current transformers

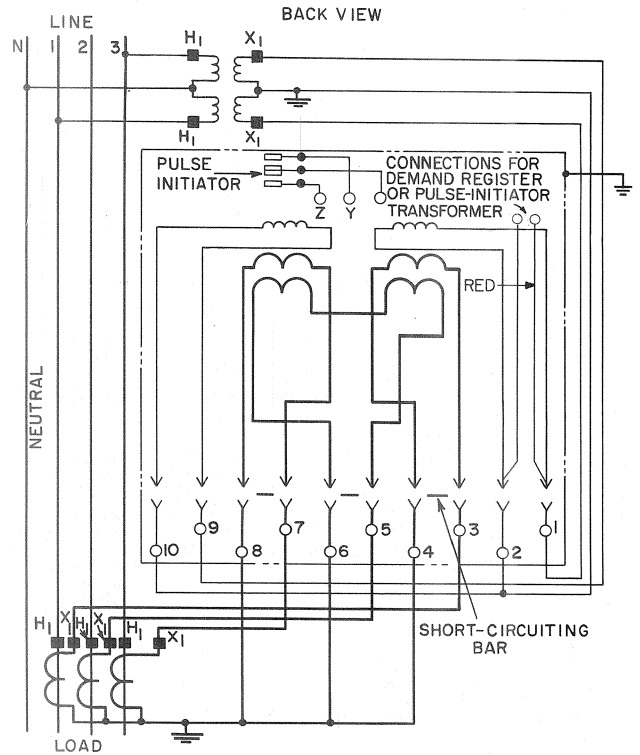

Fig. 18. Connections for Types DS-65, DSM-65, and DSW-65 meters with potential and current transformers

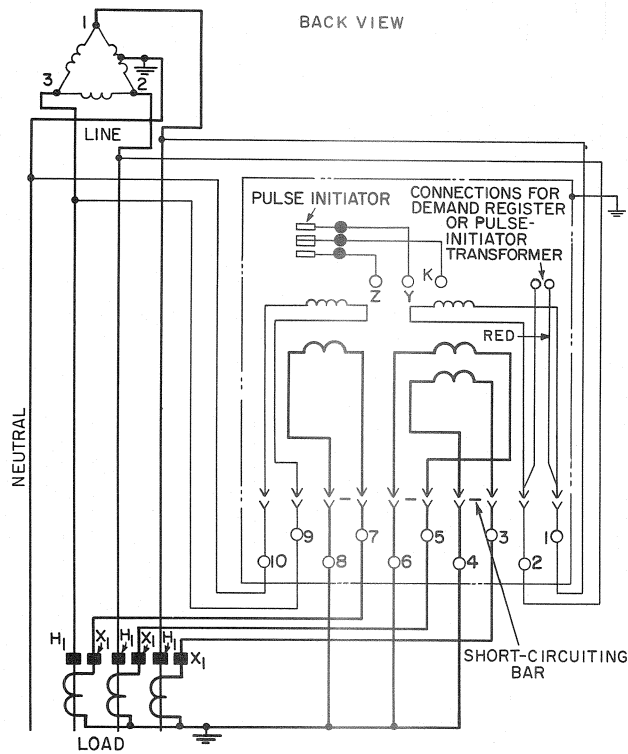

Fig. 19. Connections for Types DS-66, DSM-66, and DSW-66 meters with current transformers

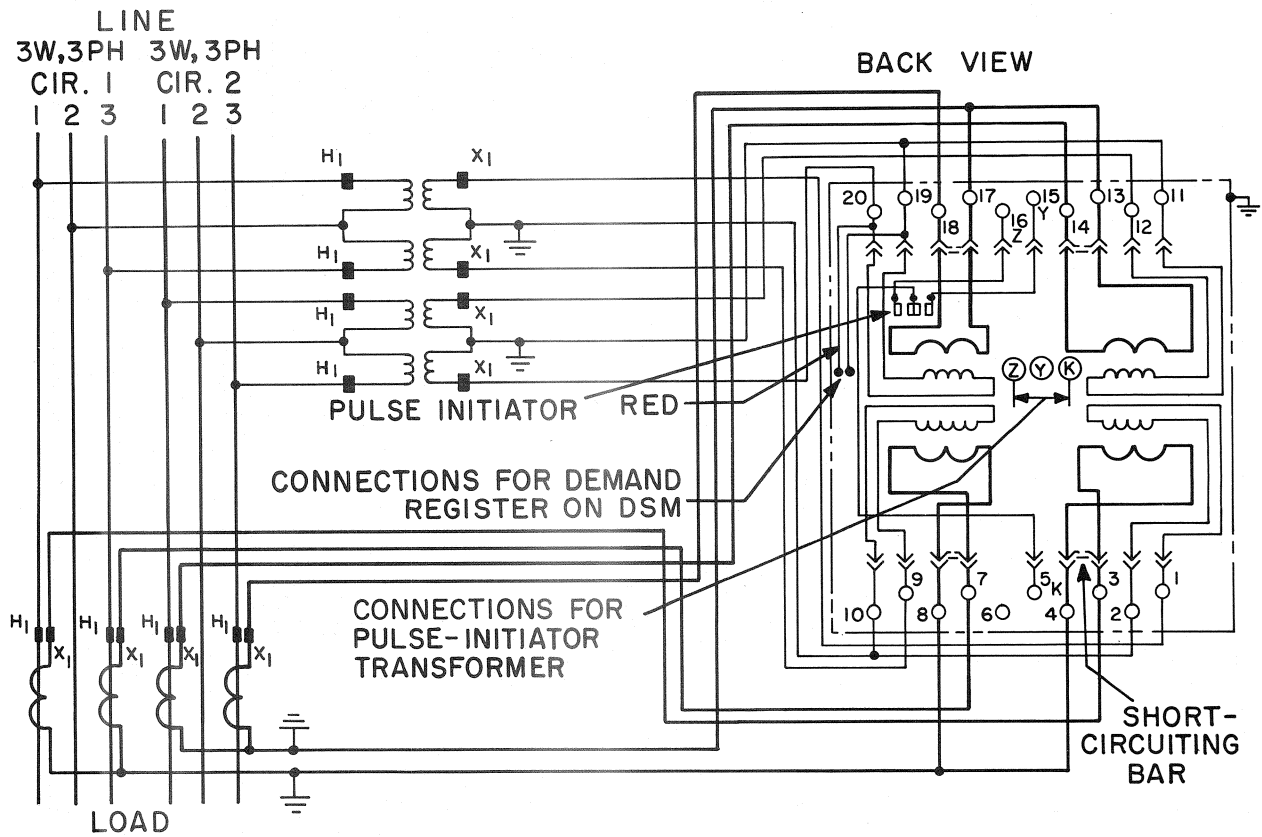

Fig. 20. Connections for Types DS-67, DSM-67, and DSW-67 meters with potential and current transformers

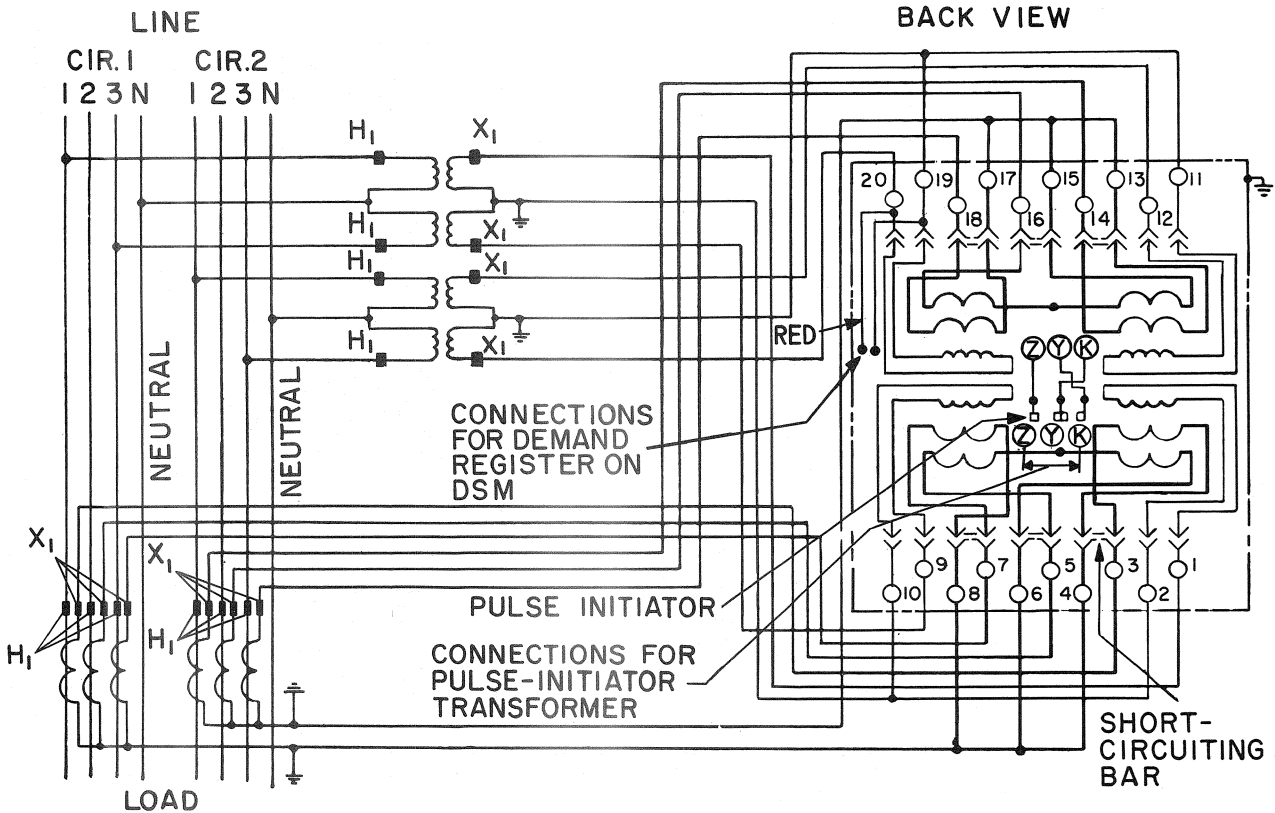
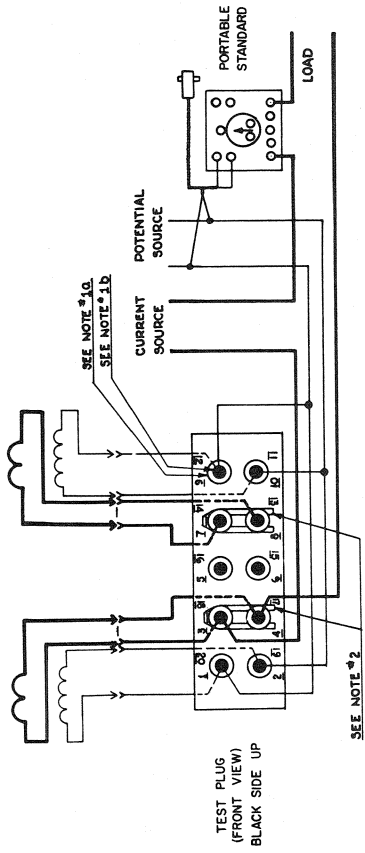
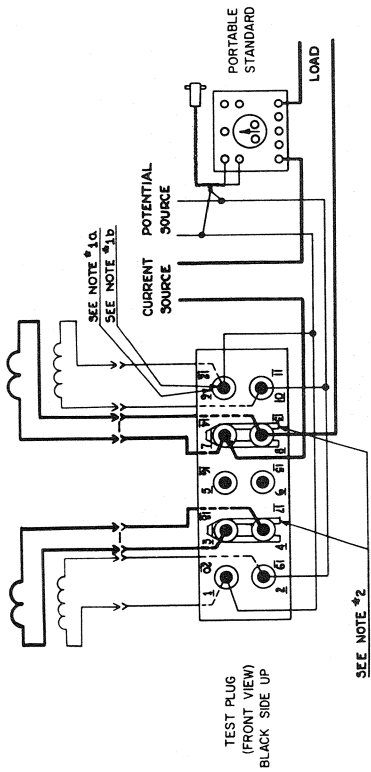

Fig. 21. Connections for Types DS-69, DSM-69, and DSW-69 meters with potential and current transformers



CONNECTIONS FOR TESTING
LEFT STATOR

NOTES	
1	CONCENTRIC BINDING POSTS G-RED THUMB NUTS CONNECT TO STUDS H-BLACK THUMB NUTS ENGAGE METER INTERNAL CONNECTIONS
2	REMOVABLE LINKS MUST BE LOCATED AS SHOWN BEFORE INSERTING PLUG



CONNECTIONS FOR TESTING
RIGHT STATOR

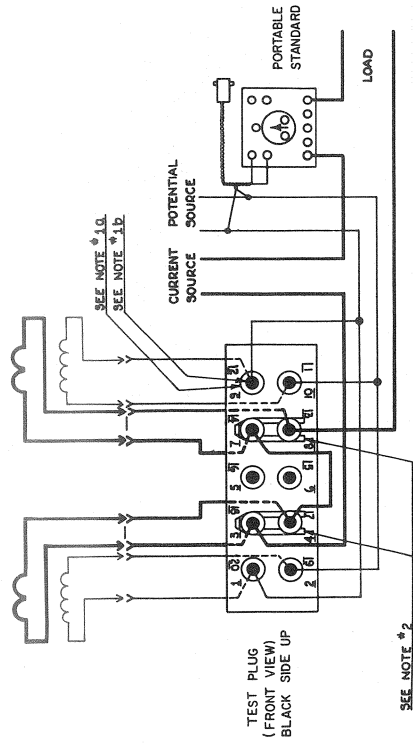

CONNECTIONS FOR TESTING BOTH STATORS
WITH POTENTIAL COILS IN MULTIPLE AND
CURRENT COILS IN SERIES

Fig. 22. Field testing connections for Type DS-63 meter, using test plug Model 12XLA12A1

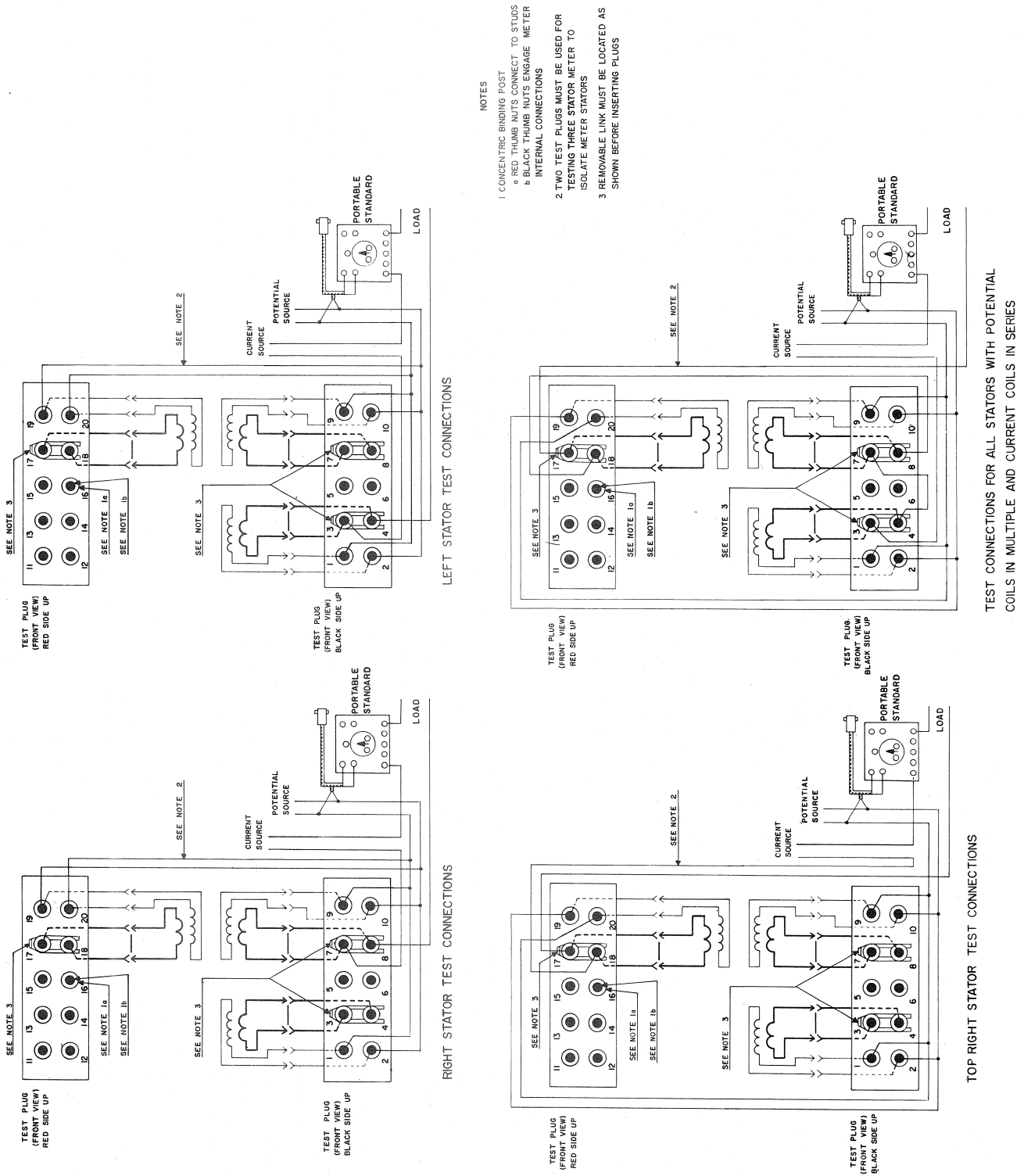
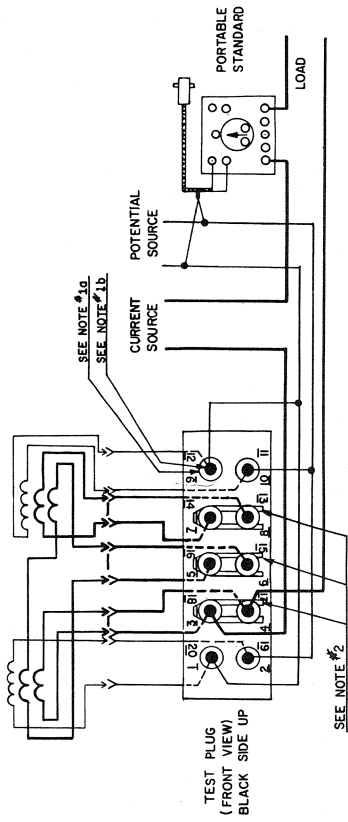
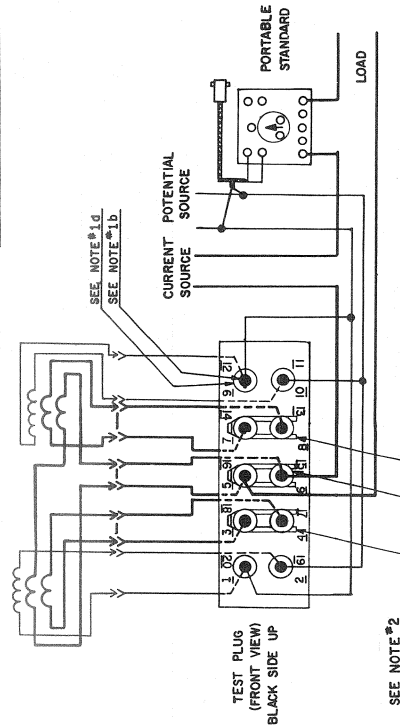

Fig. 23. Field testing connections for Type DS-64 meter, using test plug Model 12XLA12A1



CONNECTIONS FOR TESTING
LEFT STATOR

NOTES	
1.	CONCENTRIC BINDING POSTS a-RED THUMB NUTS CONNECT TO STUDS b-BLACK THUMB NUTS ENGAGE METER INTERNAL CONNECTIONS.
2.	REMOVABLE LINKS MUST BE LOCATED AS SHOWN BEFORE INSERTING PLUG



CONNECTIONS FOR TESTING
Z COIL

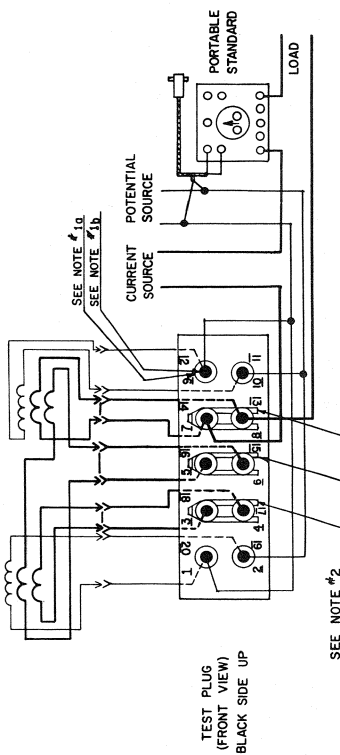

CONNECTIONS FOR TESTING
RIGHT STATOR

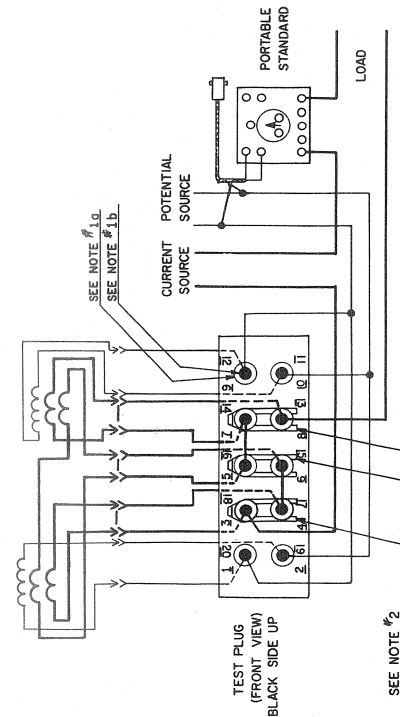

CONNECTIONS FOR TESTING ALL STATORS
WITH POTENTIAL COILS IN MULTIPLE AND
CURRENT COILS IN SERIES

Fig. 24. Field testing connections for Type DS-65 meter, using test plug Model 12XLA12A1

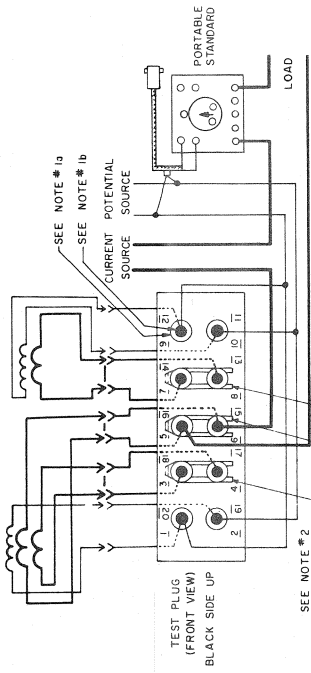

CONNECTIONS FOR TESTING LOWER SECTION OF LEFT STATOR

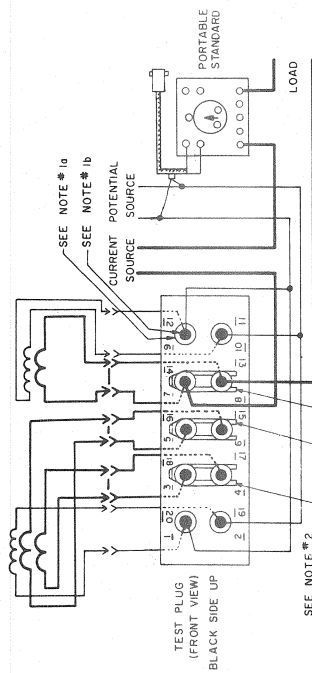

CONNECTIONS FOR TESTING RIGHT STATOR

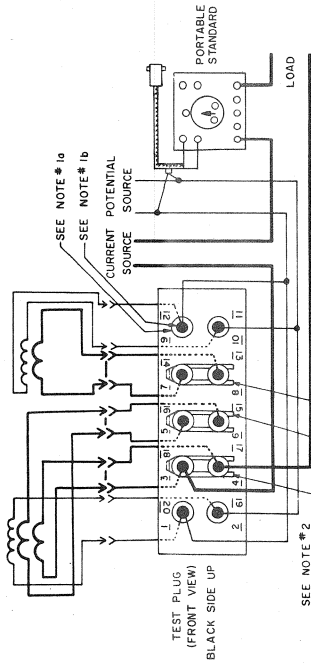

CONNECTIONS FOR TESTING UPPER SECTION OF LEFT STATOR

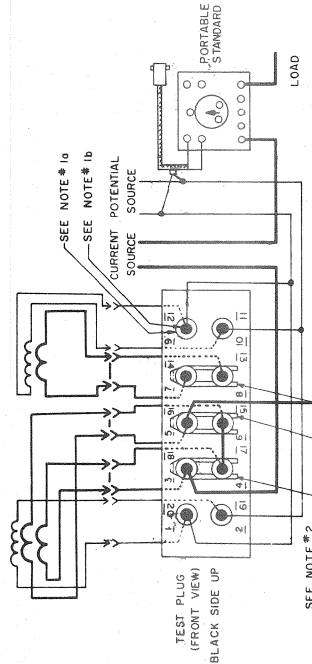

CONNECTIONS FOR TESTING COMPLETE LEFT STATOR

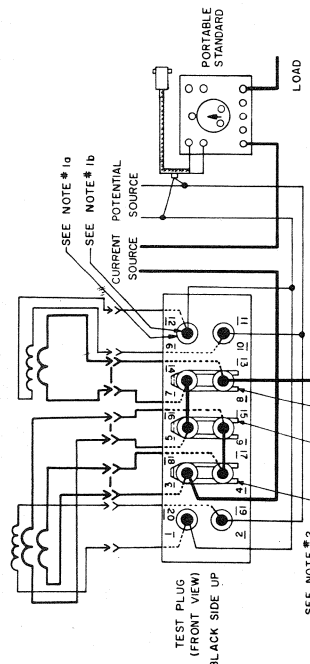

CONNECTIONS FOR TESTING ALL STATORS WITH POTENTIAL COILS IN MULTIPLE AND CURRENT COILS IN SERIES

NOTES	
1.	CONCENTRIC BINDING POSTS a-RED THUMB NUTS CONNECT TO STUDS. b-BLACK THUMB NUTS ENGAGE METER INTERNAL CONNECTIONS. REMOVABLE LINKS MUST BE LOCATED AS SHOWN BEFORE INSERTING PLUG.
2.	

Fig. 25. Field testing connections for Type DS-66 meter, using test plug Model 12XLA12A1

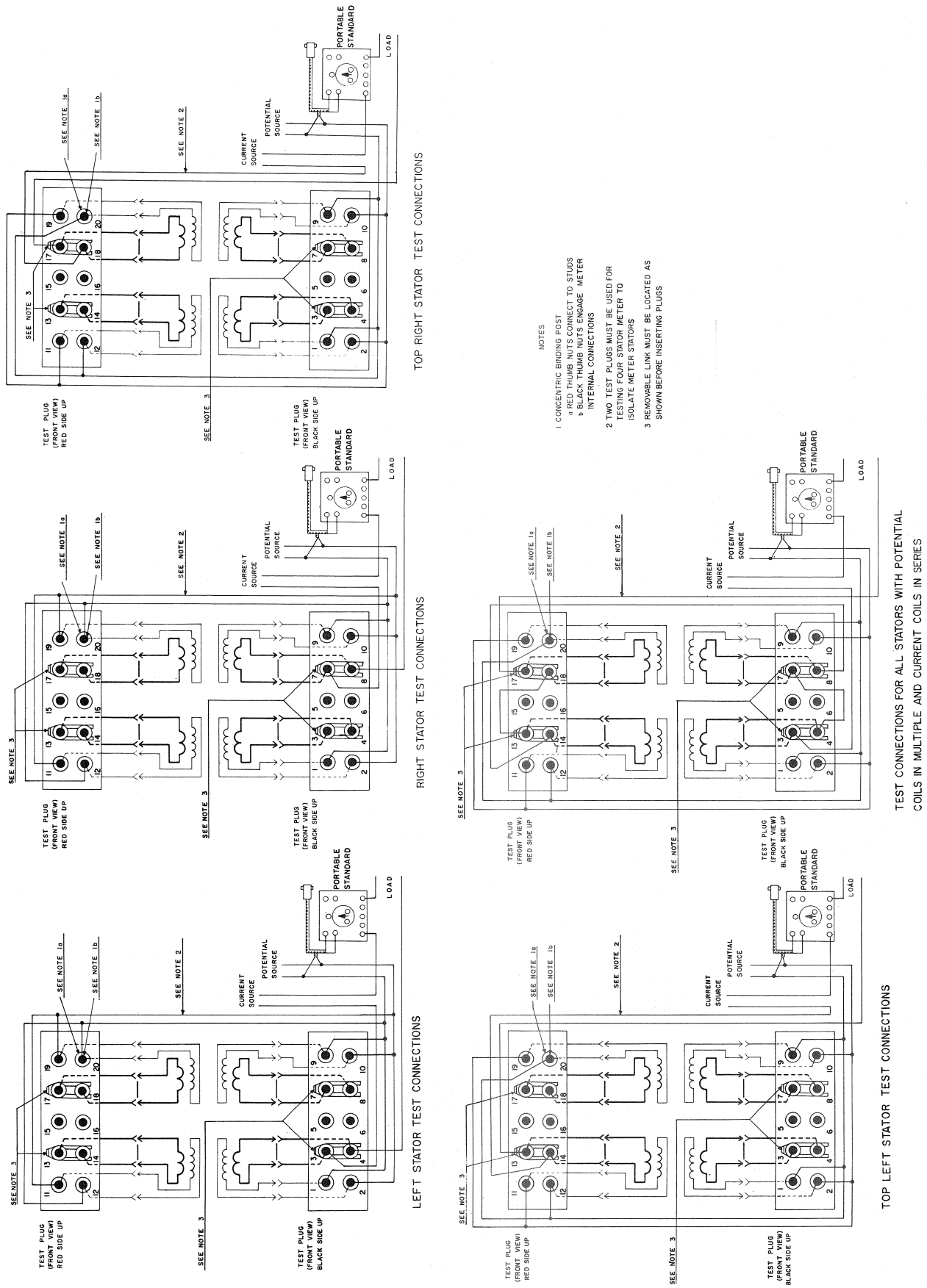

Fig. 26. Field testing connections for Type DS-67 meter, using test plug Model 12XLA12A1

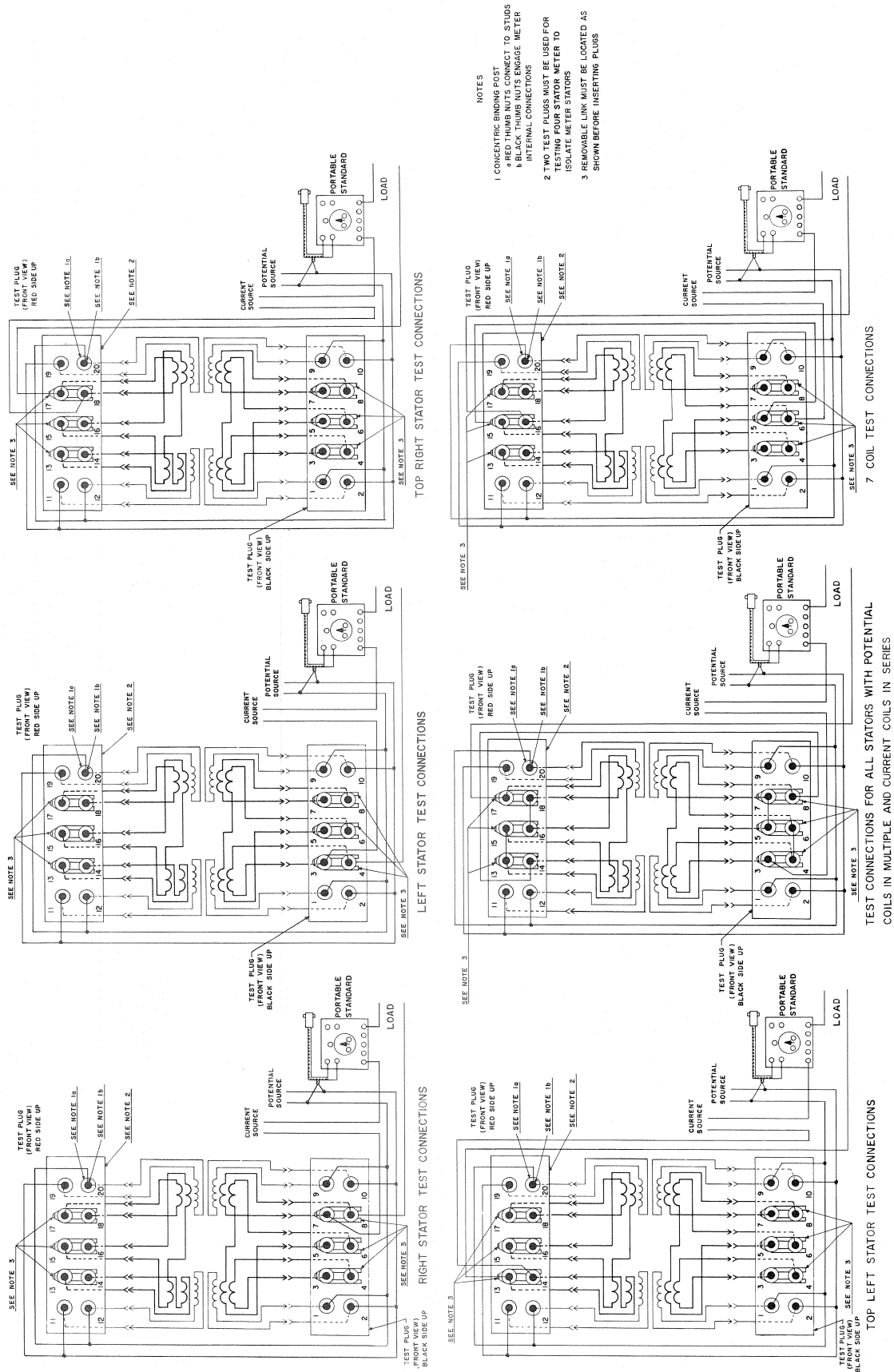

Fig. 27. Field testing connections for Type DS-69 meter, using test plug Model 12XLA12A1

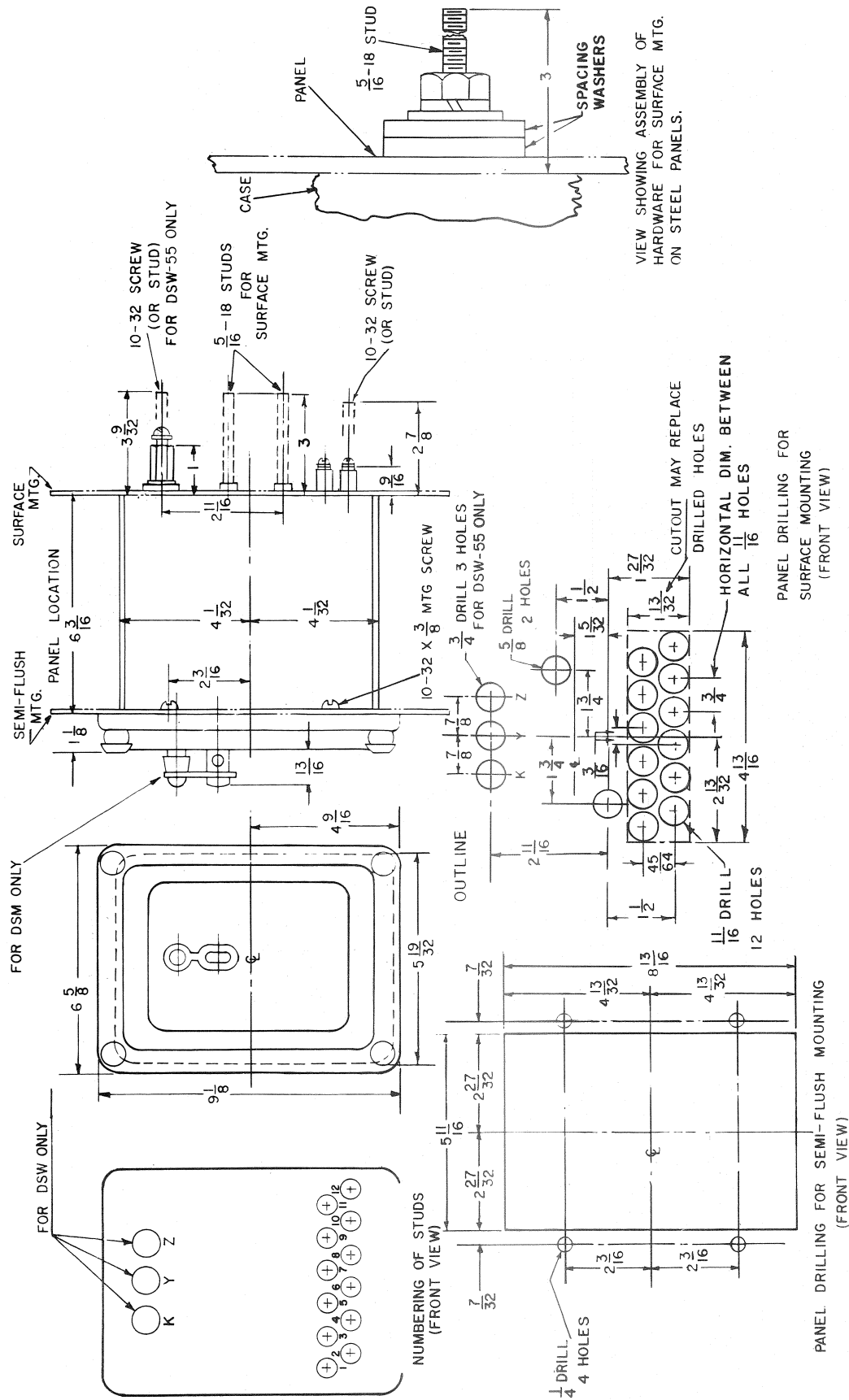

Fig. 28. Dimensions for DS-53 and -55, DSM-53 and -55, DSW-53 and -55 meters

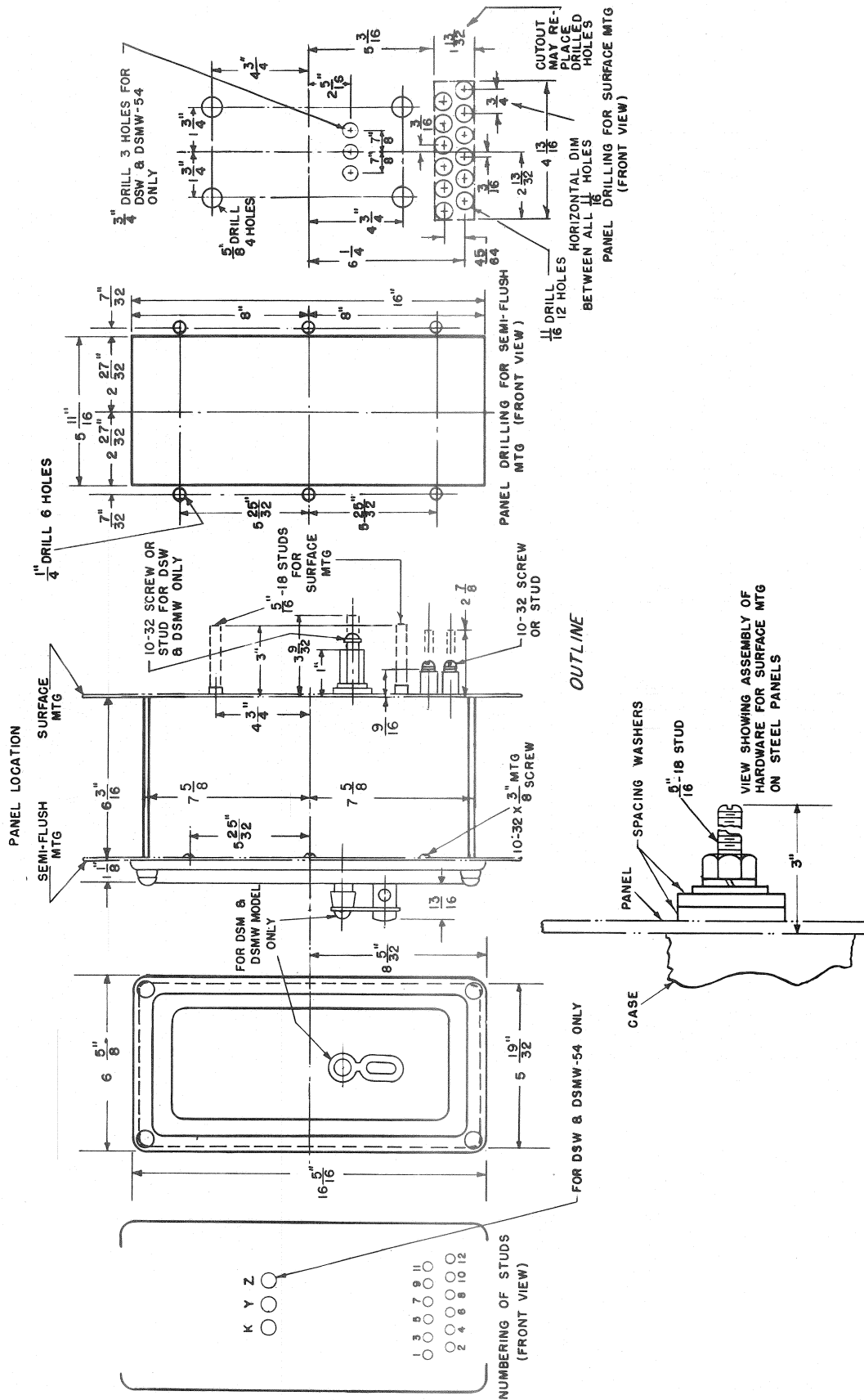

Fig. 29. Dimensions for DS-54, DSM-54, DSMW-54 type meters

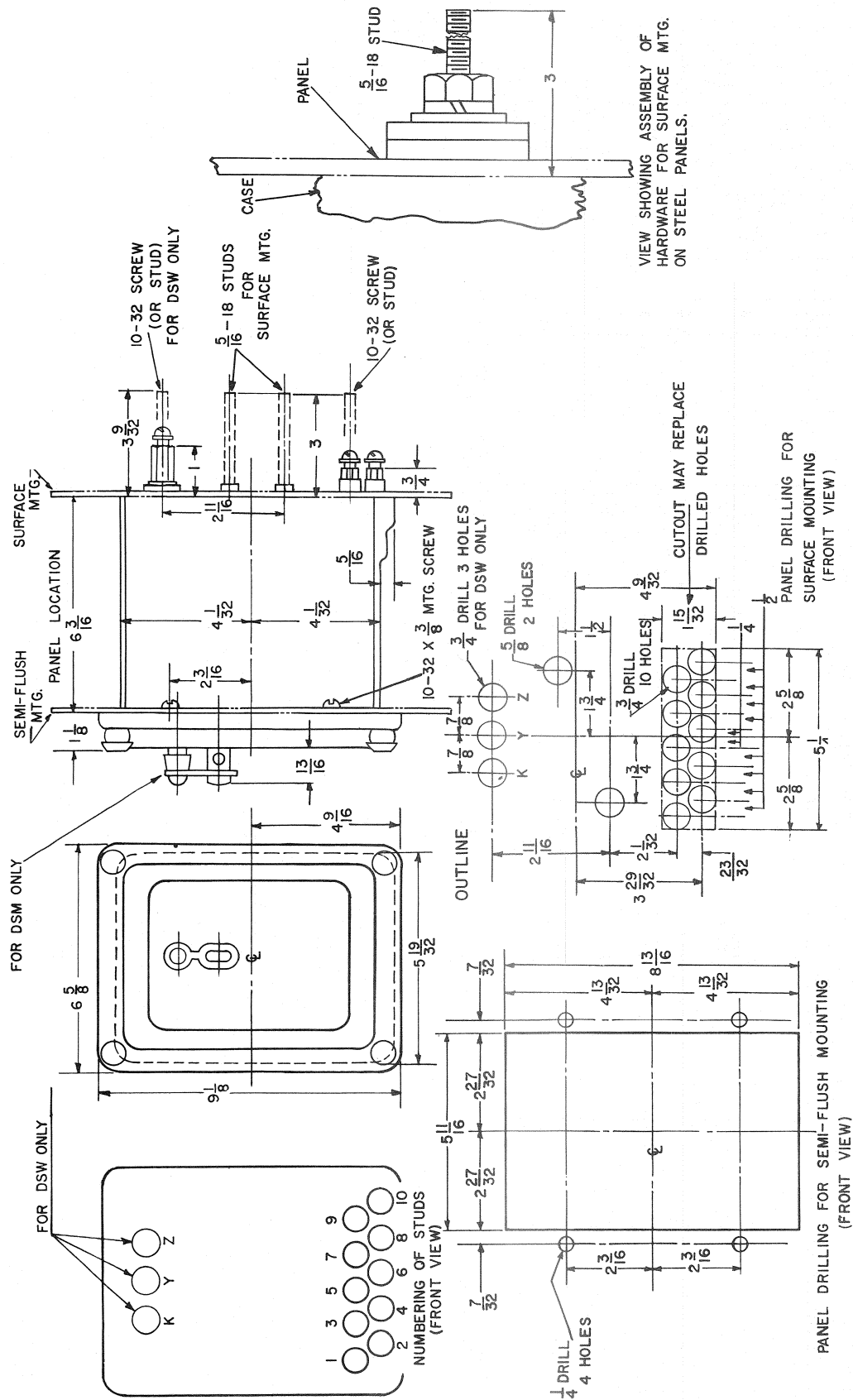

Fig. 30. Dimensions for DS-63, -65 and -66 series meters

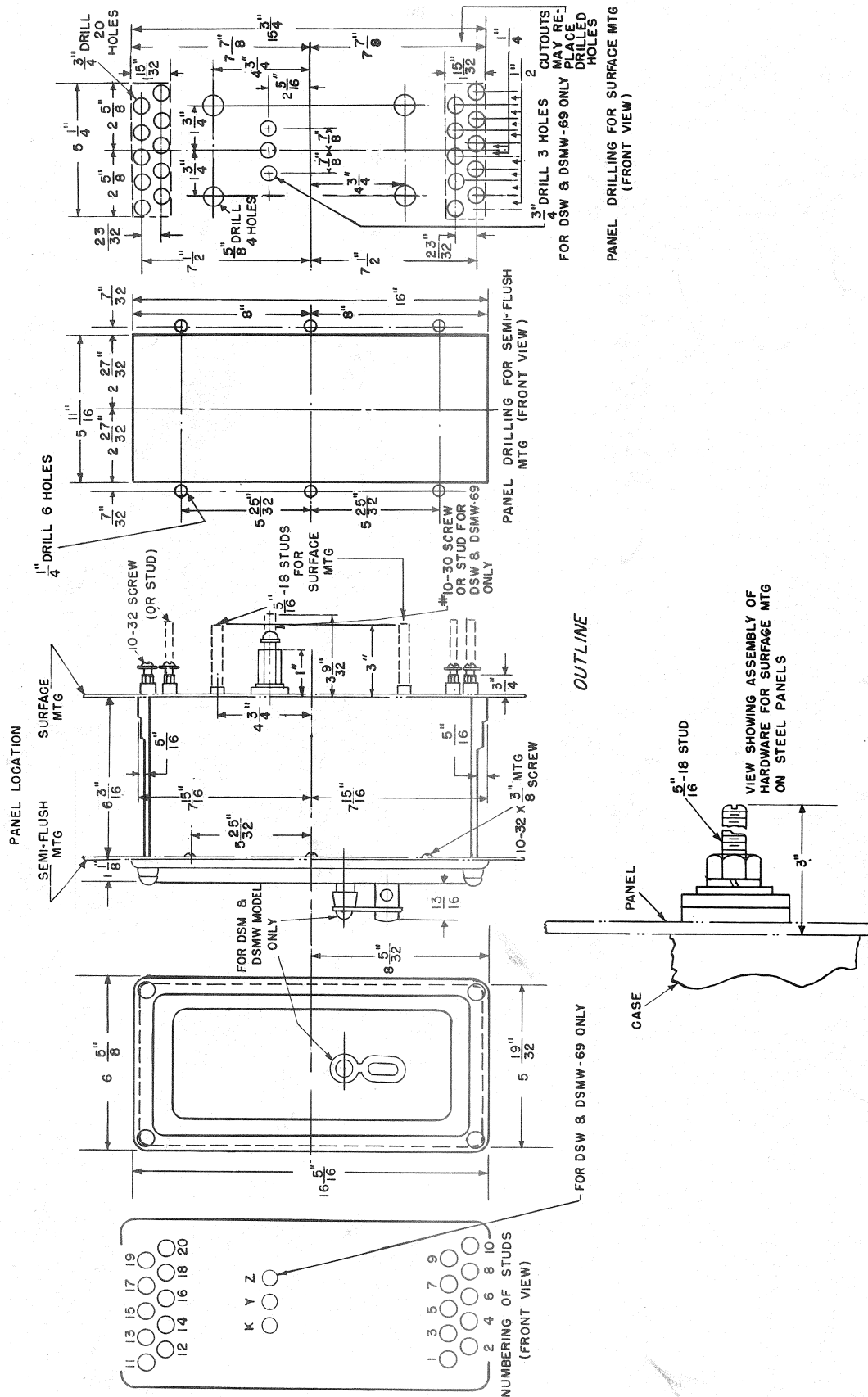

Fig. 31. Dimensions for DS-64, -67 and -69 series meters