



INSTRUCTIONS

GEK-39196B
Supersedes GEI-10951M, GEI-10952K,
and GEI-13543

EJ CURRENT-LIMITING POWER FUSES, EK FUSE SUPPORTS AND FUSE-DISCONNECTING SWITCHES

CAUTION: THE EQUIPMENT COVERED BY THESE INSTRUCTIONS SHOULD BE INSTALLED AND SERVICED ONLY BY COMPETENT PERSONNEL FAMILIAR WITH GOOD SAFETY PRACTICES. THIS INSTRUCTION IS WRITTEN FOR SUCH PERSONNEL AND IS NOT INTENDED AS A SUBSTITUTE FOR ADEQUATE TRAINING AND EXPERIENCE IN SAFE PROCEDURES FOR THIS TYPE OF EQUIPMENT.

INTRODUCTION

GENERAL

The complete lines and all sizes of Type EK fuse supports and fuse disconnecting switches are shown in the Figures 1 through 4.

GE Type EK fuse supports and switches accommodate Type EJ current-limiting fuse units. The fuse voltage rating, current rating and, in turn, the size (ferrule diameter) is determined by service requirements. Type EK switches and supports are used for indoor installations, while Type EKO are used outdoors. The dash one (-1) designation indicates a fuse support, and the dash three (-3) a fuse disconnecting switch. The letter suffix following the (-1) or the (-3) shows the fuse size. Example: Type EK-1B indicates that the device is an indoor fuse support for a Size B, Type EJ, current-limiting fuse unit. Ferrule diameters corresponding to fuse sizes are shown in Table I.

TABLE I

Fuse Size	Ferrule Diameter
B	1-9/16 inches
C	2 inches
D	3 inches
DD	two--3 inch in parallel
EE	two--4 inch in parallel

A Type EJ fuse unit - for indoor use - or a Type EJO fuse unit - for indoor or outdoor use - consists of a fuse tube having metal ferrules at each end and containing current-responsive elements surrounded by a quartz filler. When the fuse functions, the arc resulting from the melting of the current-responsive elements is cooled by the adjacent filler and

extinguished without any expulsion of gases or material from the tube. The maximum current passing through the fuse before the arc is extinguished is limited to a value considerably lower than the maximum short-circuit current usually available in the circuit.

APPLICATION

Type EK fuse supports, with Type EJ current-limiting fuses, are used for short-circuit protection of power transformers and feeder circuits. The Type EK fuse disconnecting switches are similar, except that the contact assemblies are designed to permit the fuse unit to be used as a disconnecting switch.

NOTE: Check with factory for fuses to be used in hazardous locations.

RATINGS

The EK mountings are available in voltage ratings from 2400 to 34,500. The standard terminals available for Type EK fuse mountings are adjustable to take a range of conductor sizes from No. 2 wire to 250 MCM cable. Terminals should be ordered separately.

RECEIVING, HANDLING AND STORAGE

RECEIVING

Immediately upon receipt of a fuse support or switch, examine it for any damage or loss sustained in transit. If injury or rough handling is evident file a damage claim at once with the transportation company and promptly notify the nearest General Electric Sales Office. Also, check the contents of all crates and boxes, separate from the switch parts, against the shipping memorandum for the quantity of parts received. Notify the General Electric Sales Office of any shortages or discrepancies.

All indoor supports and disconnecting switches are shipped fully assembled.

Outdoor supports and switches are fully assembled for domestic shipment. For export shipments, channel bases, switch or support parts, and insulators, are each packed separately.

One set of fuse-unit fittings is included with a Type EK-3 or EKO-3 fuse disconnecting switch, and is always shipped tied to the switch parts.

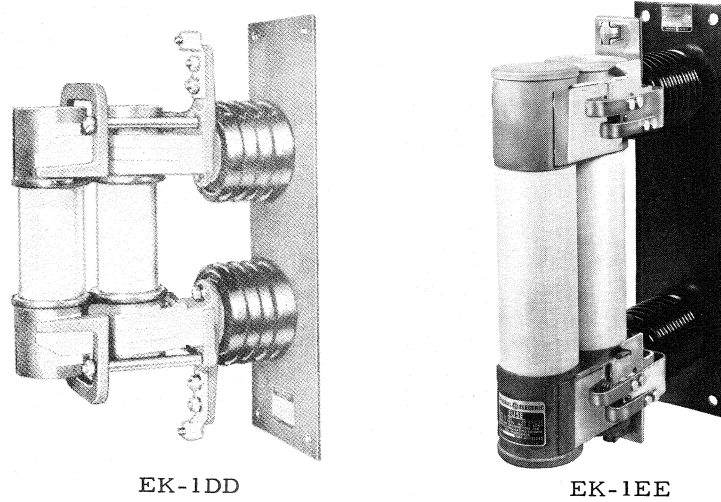
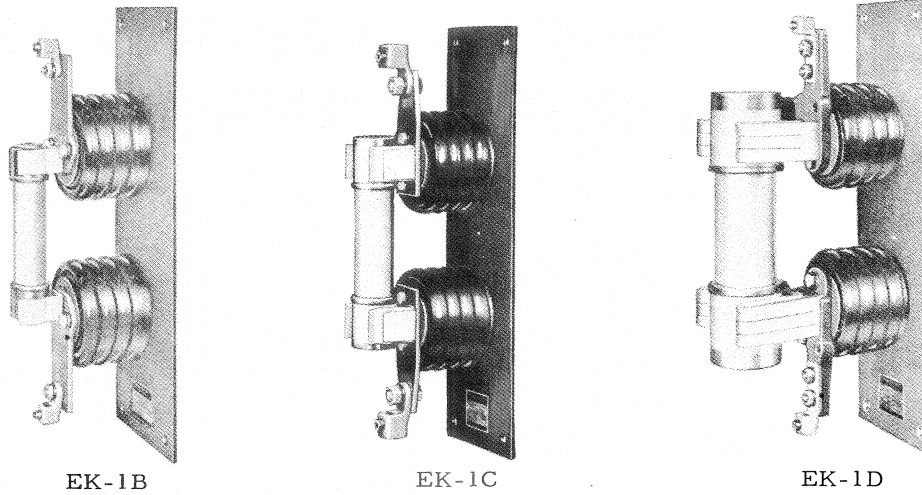

Fig. 1. Type EK-1 fuse supports (indoor) †

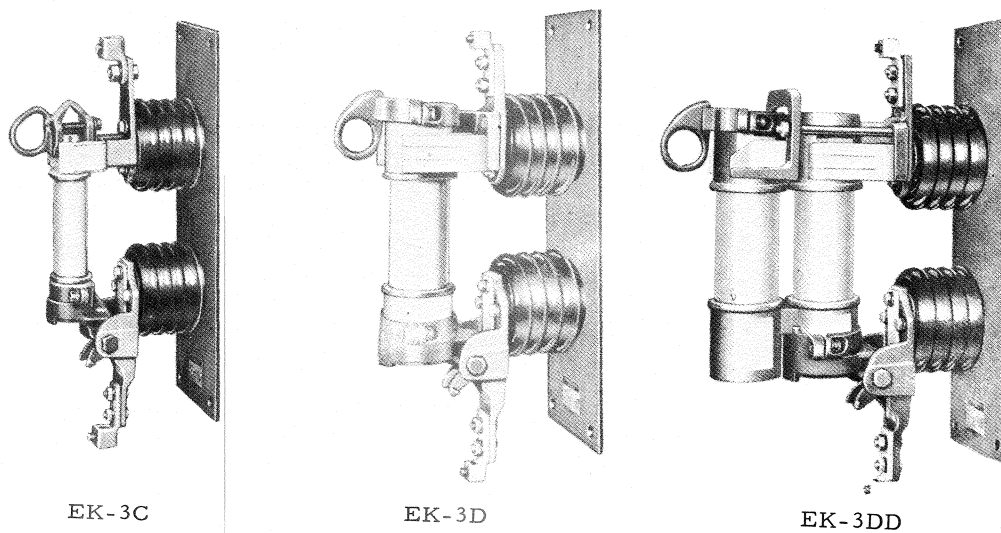

Fig. 2. Type EK-3 fuse-disconnecting switches (indoor) †

†Terminals shown on the units illustrated are not normally furnished as part of the unit. They must be purchased separately.

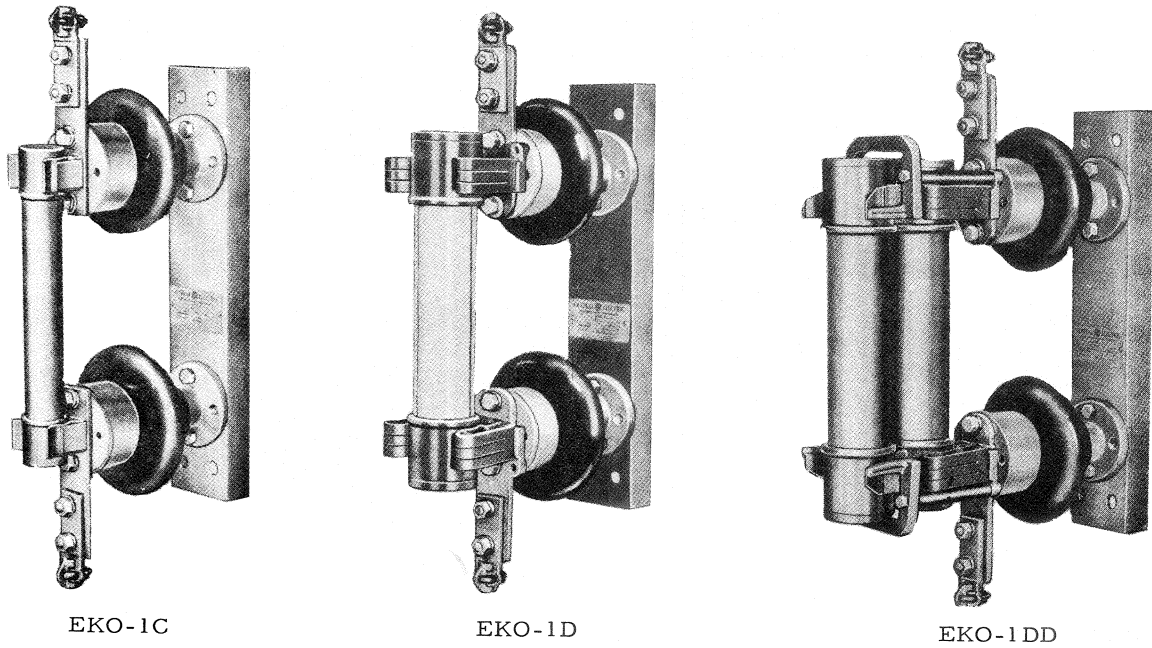

Fig. 3. Type EKO-1 fuse supports (outdoor)†

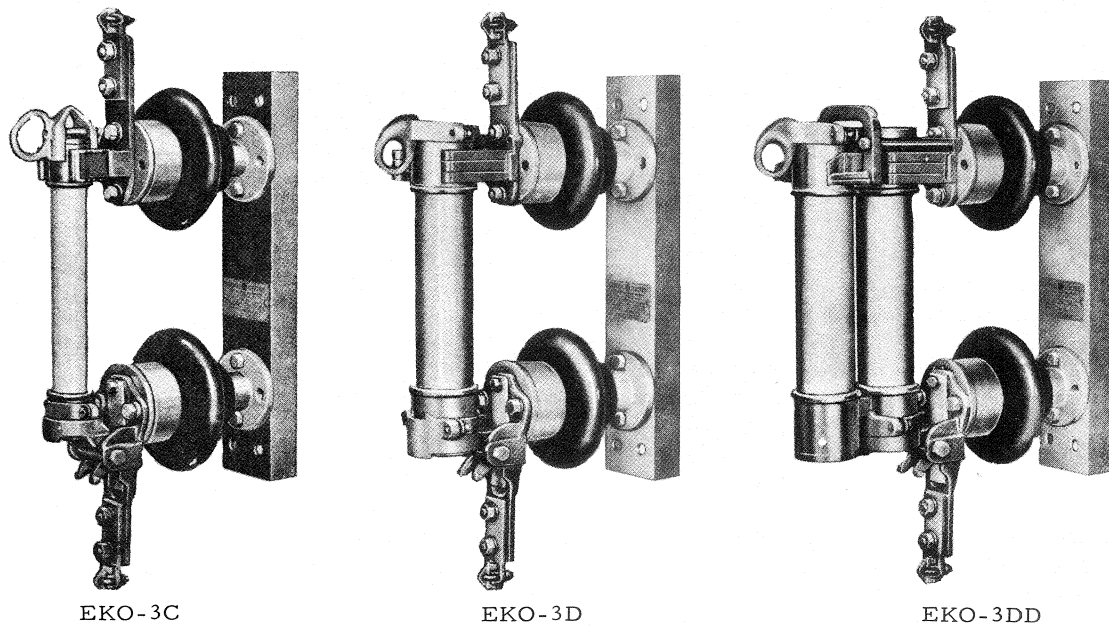

Fig. 4. Type EKO-3 fuse-disconnecting switches (outdoor)†

† Terminals shown on the units illustrated are not normally furnished as part of the unit. They must be purchased separately.

HANDLING

Care should be exercised in handling the insulators and fuses since they are breakable.

STORAGE

Supports and switches for indoor service should be kept in a dry place before installation. Support and switches for outdoor service may be stored anywhere; but if stored outdoors, care should be taken to see that the insulator units are kept upright to prevent the collection of water inside the porcelain parts.

INSTALLATION

LOCATION

Type EK-1 or EKO-1 supports may be mounted either vertically, or horizontally with the fuse on top. Fuse disconnecting switches, Type EK-3 or EKO-3, must be in the vertical position. When indoor supports or switches are mounted on a flat surface, 1/2-inch spacers must be placed under the base in order to provide clearance for the insulator mounting-bolt heads.

There should be ample room for installing and removing the fuse units. In the case of fuse disconnecting switches, clearance is necessary for opening the switch.

MOUNTING

After unpacking, and before installation on the supporting structure, the location of the mounting holes in the base should be compared with those in the structure. In case of a discrepancy, check with approved outline drawing and take appropriate action.

In mounting the fuse supports and switches, especially those with outdoor insulator units, the rigging should be attached to the bases, and not to the insulator unit, contacts, or other parts which might be injured during the hoisting operation.

With the unit in the mounting position, check to see that the base is supported evenly, so it will not be distorted when the mounting bolts are tightened.

CONNECTIONS

The conductors should be clean and bright before connecting to the terminals. In the case of flat bars,

there should be no dents or burrs. Terminals which accommodate conductors from No. 2 wire to 250 MCM cable should be ordered separately.

The insulators should not be subject to mechanical or thermal stresses transmitted through the conductors. Bar or pipe connections from buses should be provided with flexible connectors, unless they are so shaped as to eliminate strain due to expansion and contraction of the bus.

ADJUSTMENTS

If the support is properly mounted, so there is no buckling of the base, there should be no need for adjustment of switch parts. If, in the case of the disconnecting switches, the fuse strikes the clip on one side more than the other, the bolts holding the hinge support to the lower insulator may be loosened, and the hinge support must be adjusted so the upper fuse ferrule enters the clips centrally. Tighten the bolts when correct adjustment is obtained.

When a fuse support or switch is energized, the fuse units should only be inserted by means of suitable insulated fuse tongs. The fuse unit should only be removed by hand after the circuit has been completely de-energized and grounded for maintenance.

EK-1 OR EKO-1 SUPPORTS

To remove the fuse unit from an EK-1 or EKO-1 fuse support, the tongs should first be made to grip the fuse unit firmly by rotating the shaft, causing the jaws of the tongs to close. The fuse unit may then be removed, as shown in Fig. 6.

When inserting a new fuse unit, be sure the fuse is firmly seated in the clips before removing the tongs.

EK-3 OR EKO-3 SWITCHES

With Type EK-3 and EKO-3 fuse disconnecting switches, fittings for the fuse unit are furnished to make it suitable for use as a disconnecting fuse. Before inserting the fuse unit in the EK-3 or EKO-3 switches, these fittings, shown in Figs. 7 and 8, must be assembled on the fuse unit. To attach these fittings to a fuse unit, slide them on the ferrules of the fuse unit and fasten in the position shown in Fig. 7. With a Size DD fuse unit, attach the hinge fitting to the bottom ferrule of one tube and the operating eye to the top ferrule of the other tube. In

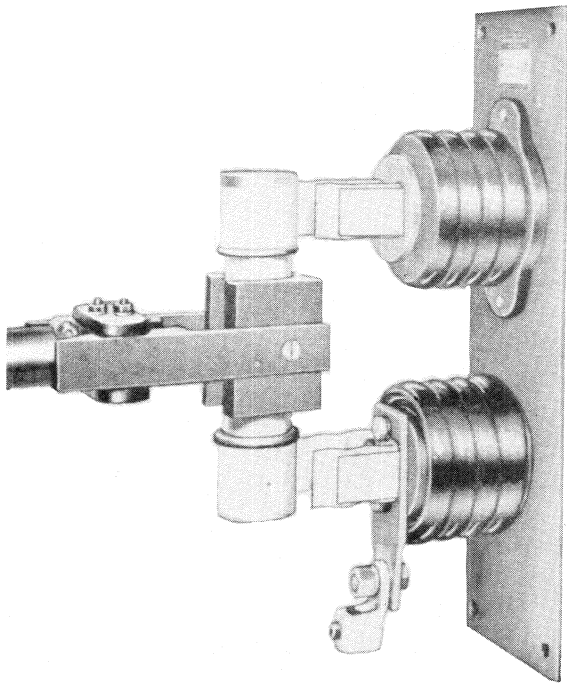

Fig. 5. Removal or insertion of fuse unit from EK-1C support

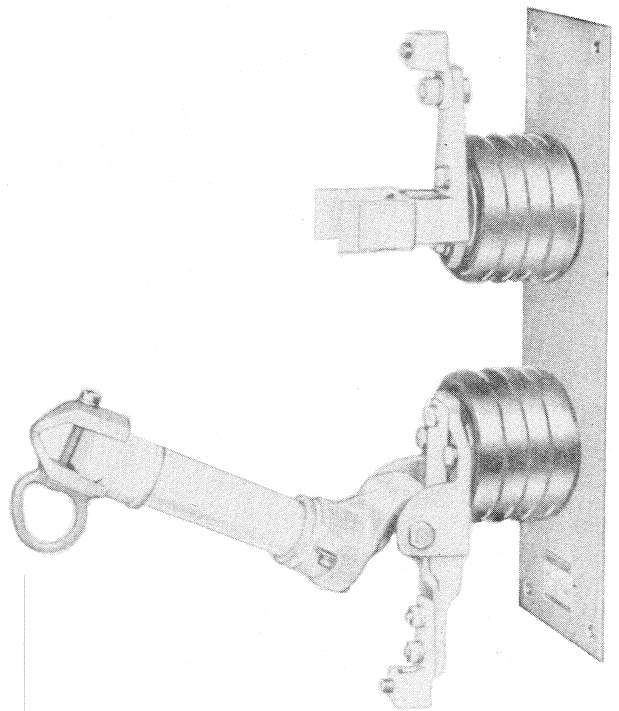

Fig. 6. EK-3C fuse-disconnecting switch in the open position

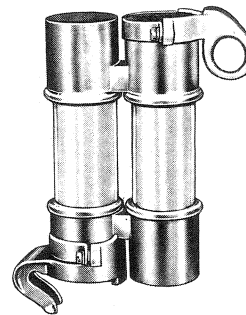
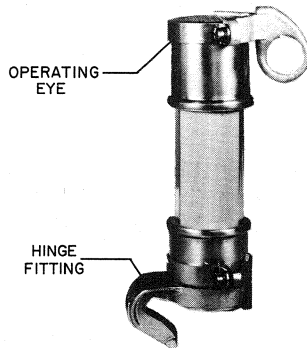

Fig. 7. Fuse units assembled with fittings for Type EK-3D and EK-3DD fuse-disconnecting switch

all cases, the hinge fitting should be located at the end of the fuse containing the indicating target, for ease of viewing from below. The target end of the fuse units have a concave appearance or button indicators to indicate blown fuses. (See Fig. 9). For size DD fittings, the connecting block should seat firmly in the slot cut in the hinge fitting. The fittings are provided with slotted cap screws to hold

the fuse firmly. These screws should only be tightened firmly with a hand screwdriver; excess force may cause the glass to crack.

To insert size C, D, or DD fuse units, grip the tube firmly with the tongs. Insert the point of the hinge fitting behind the hinge bolt and lower the unit until it rests on the bolt. The tongs can then be re-

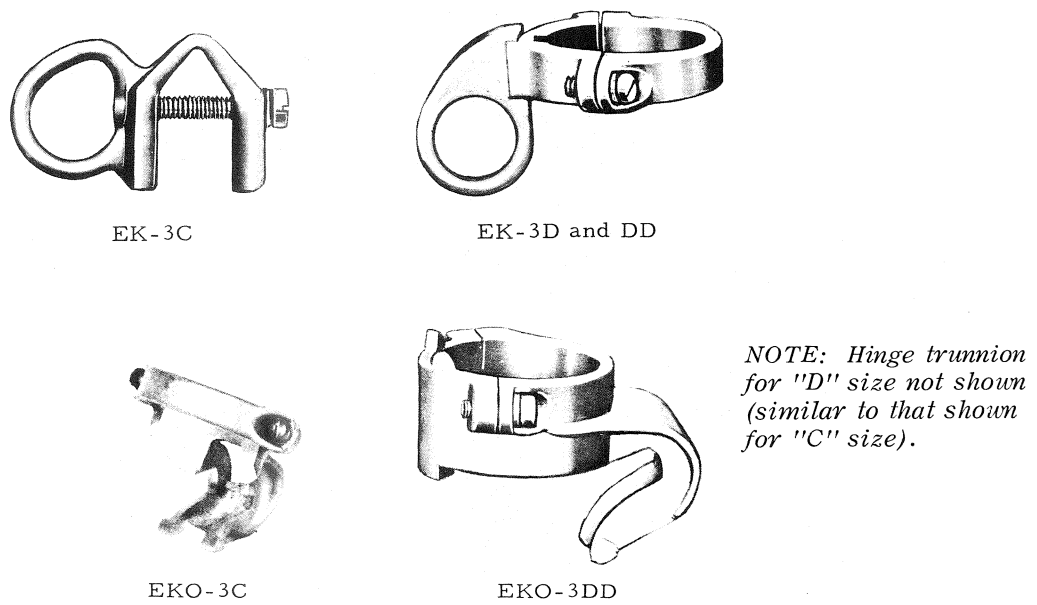

Fig. 8. Fuse fittings for Type EK-3 and EKO-3 fuse-disconnecting switches

moved; then insert the fuse hook in the operating eye and rotate the blade into the closed position.

To remove the C, D, or DD unit from the switch, insert the hook in the operating eye and open the switch to the position shown in Fig. 6. Grip the tube firmly in the jaws of the fuse tongs and lift straight up.

FUSES

When a fuse unit functions, it should be replaced by a complete new unit. Always use fuse tongs for handling unless special means are provided for disconnecting the fuse support from all sources of power. If used in a fuse disconnecting switch, the fittings should be removed from the blown unit and transferred to a replacing unit. The time required to replace a blown fuse unit in a disconnecting switch may be considerably shortened if a spare fuse unit with fittings in place is kept on hand at each installation.

The indicating target operates when the fuse unit functions. Its operation is provided by a separate mechanism within the fuse tube, and is not due to any pressure developed by the main fuse elements in functioning. The appearance of the target for fuse units is shown, before and after operation, in Figure 9. The fuse units either have an indicator consisting of a small plunger which projects from the end of the fuse unit after the fuse unit functions, or a bulged end.

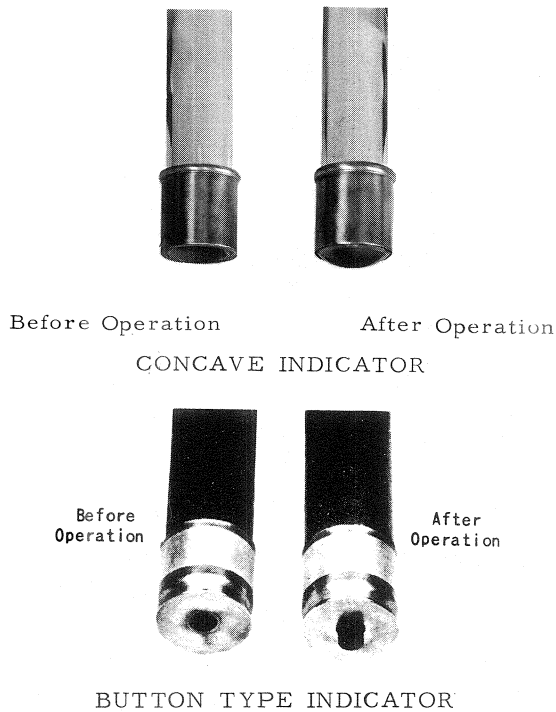

Fig. 9. Typical blown fuse indicators

MAINTENANCE

GENERAL

When installing a new fuse unit in a support or switch, care must be taken to place the indicating end in a position where it can be seen.

The ferrules of the Type EJ or EJO fuse units are silver plated, and provide low contact resistance when the fuse clips are periodically checked for tightness.

For disconnecting switches, the time required to replace a "blown" fuse is considerably shortened if spare fuse units, with fittings attached, are kept on hand. Make sure fuse holder is clean before assembling the fuse.

NOTE: Gloves may be required when removing fuses because of high fuse surface temperature.

NOTE: Do not use fuses which have been submerged in water or other liquids.

INSPECTION

At intervals of about one year (or more often depending on local conditions), an inspection of contact surfaces and other parts should be made to make sure damaged parts are replaced, the insulators and fuse tubes are free of contaminants, and the contacts are maintained in a bright appearance.

RENEWAL PARTS

When ordering renewal parts, address the nearest General Electric Sales Office and furnish model number, the quantity required, and, if possible, the

number of the requisition on which the fuse support or switch was originally furnished.

When ordering or replacing fuse units, specify the quantity required and give the model number, voltage and current rating as stamped on the fuse nameplate.

A recommended list of renewal parts are shown in Tables II, III and IV.

TABLE II
FUSE CLIPS*

Fuse Size	Model No. **
B	9F61BWW460
C	9F61BWW457
D	9F61BWW459
D-D	9F61BNW402 (Upper Clips)

*Clips only - does not include mounting bracket or plate.

**Clip for one end of fuse only.

TABLE III
OPERATING EYE

Fuse Size	Model No.
C	9F61BFW394
D	9F61AWW612
D-D	9F61AWW612

TABLE IV
HINGE TRUNNION (FRONT-CONNECTED UNITS)

Fuse Size	Model No.
C	9F61BJW397
D	9F61BKW398
D-D	9F61BLW399

**GENERAL ELECTRIC COMPANY
DISTRIBUTION TRANSFORMER BUSINESS DEPARTMENT
HICKORY, NORTH CAROLINA 28601**

GENERAL  ELECTRIC