

RENEWAL PARTS

TYPE AM-13.8-150, -250, -500 MAGNE-BLAST AIR CIRCUIT BREAKERS

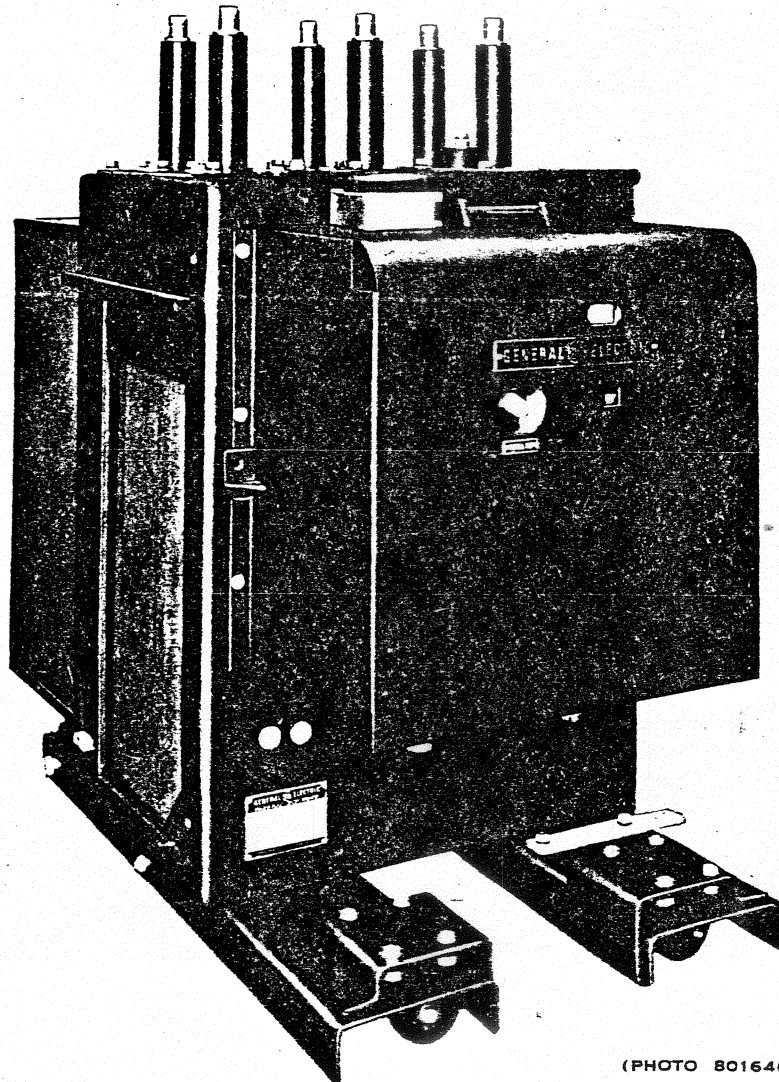

(PHOTO 8016467)

Fig. 1. Type AM-13.8 magne-blast air circuit breaker

When ordering renewal parts, give quantity, catalog number, description of each item required, and complete nameplate reading.

GENERAL  ELECTRIC

TYPE AM-13.8 AIR CIRCUIT BREAKERS

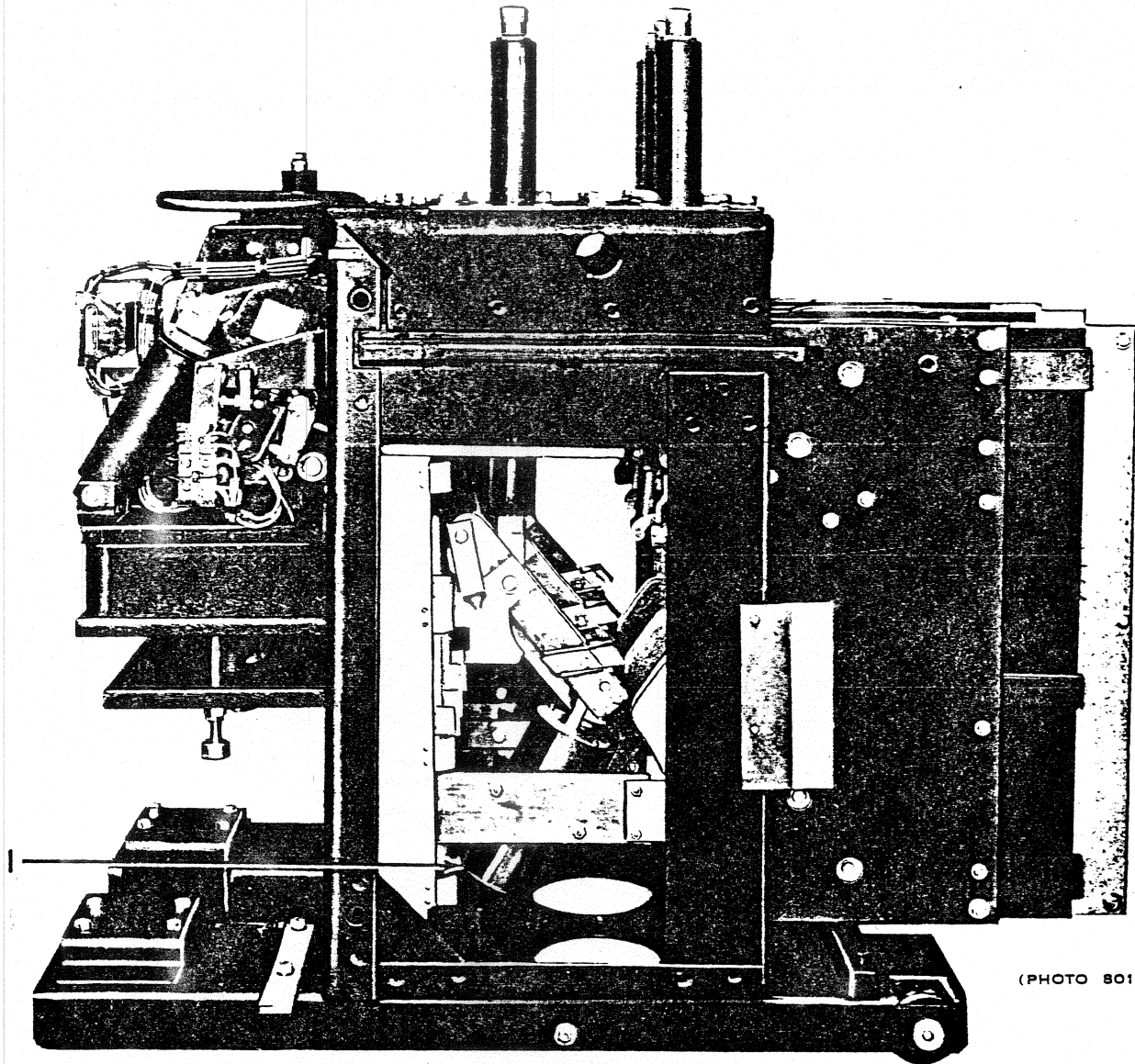

(PHOTO 8016463)

Fig. 1A. Type AM-13.8-500-2 magne-blast air circuit breaker
with mechanism cover and box-barrier removed

TYPE AM-13.8 AIR CIRCUIT BREAKERS

GEF-3875C

ORDERING INSTRUCTIONS

1. Always specify the complete nameplate reading of the breaker, and when furnished, of the mechanism.
2. Specify the quantity, catalog number, reference number, description of part and this bulletin number.
3. Standard hardware (such as screws, bolts, nuts, washers, etc.) is not listed in this bulletin. Such items should be purchased locally, if feasible.
4. For prices, refer to the nearest office of the General Electric Company.

NOTE:- All references to "right," "left," "center," "front," and "rear" designate the location of the part when facing the mechanism end of the breaker.

The following parts are recommended for normal maintenance:

(All other parts listed on following pages are seldom required.)

Fig. No.	Ref. No.	MVA	AMP	Catalog Number for Type			No. Req.	Description
				AM-13.8-0	AM-13.8-1	AM-13.8-2		
2	1	ALL	ALL	263B292P2	263B292P2	263B292P2	3	Booster cylinder
5	176	ALL	ALL	6514946G2	383A903G1	383A903G1	3	Secondary arcing finger
5	177	ALL	ALL	389A616P6	6445087P1	6445087P1	3	Buffer
5	177A	{ 150, 150A, 250, 250A, 500, 500A }	1200	389A616G1	6557243P1	6557243P1	6	Clamp for buffer
5	177A	500B, 500BA	1200	389A616G2	6557243P2	6557243P2	6	Clamp for buffer
5	177A	ALL	2000	389A616G2	6557243P2	6557243P2	6	Clamp for buffer
5	178	{ 150, 150A, 250, 250A, 500, 500A }	1200	236C791P8	236C791P8	236C791P8	12	Primary contact finger
5	178	500B, 500BA	1200	236C791P8	236C791P8	236C791P8	24	Primary contact finger
5	178	ALL	2000	236C791P8	236C791P8	236C791P8	24	Primary contact finger
5	198	{ 150, 150A, 250, 250A, 500, 500A }	1200	6509787P1	6509787P1	6509787P1	12	Spring for primary contact finger
5	198	500B, 500BA	1200	6509787P1	6509787P1	6509787P1	24	Spring for primary contact finger
5	198	ALL	2000	6509787P1	6509787P1	6509787P1	24	Spring for primary contact finger
5A	211	ALL	ALL	6592336P1	6592336P2	6592336P2	6	Upper runner, insulation (bottom)
5A	213	ALL	ALL	6591742P1	6591742P1	6591742P1	6	Upper runner, insulation (top)
5A	218	ALL	ALL	-----	175V232P1	175V232P1	3	Protector for blowout coil
6	250	ALL	ALL	802B742G3	802B742G3	802B742G3	3	Secondary arcing contact, movable
6	251	{ 150, 150A, 250, 250A, 500, 500A }	1200	6591644P7	6591644P7	6591644P7	3	Primary contact, movable
6	251	500B, 500BA	1200	6591644P7	6591644P7	6591644P7	6	Primary contact, movable
6	251	{ 150, 150A, 250, 250A, 500, 500A }	1200	6591644P8	6591644P8	6591644P8	3	Primary contact, movable
6	251	500B, 500BA	1200	6591644P8	6591644P8	6591644P8	6	Primary contact, movable
6	251	ALL	2000	6591644P7	6591644P7	6591644P7	6	Primary contact, movable
6	252	ALL	2000	6591644P8	6591644P8	6591644P8	6	Primary contact, movable
7, 8	400	ALL	ALL	6375521G2	6375521G2	6375521G2	1	Closing coil, 125-volt, d-c
7, 8	400	ALL	ALL	6375521G1	6375521G1	6375521G1	1	Closing coil, 250-volt, d-c
11	499	ALL	ALL	6174582G1	6174582G1	6174582G1	1	Potential trip coil, 125-volt, d-c
11	499	ALL	ALL	6174582G2	6174582G2	6174582G2	1	Potential trip coil, 250-volt, d-c
11	499	ALL	ALL	6174582G14	6174582G14	6174582G14	1	Potential trip coil, 230-volt, a-c
11	499	ALL	ALL	6275070G1	6275070G1	6275070G1	1	Potential trip coil, 24-volt, d-c
11	499	ALL	ALL	6275070G2	6275070G2	6275070G2	1	Potential trip coil, 48-volt, d-c
16	652	ALL	ALL	6275017G33	6275017G33	6275017G33	1	Coil for undervoltage device, a-c
16	652	ALL	ALL	6275017G19	6275017G19	6275017G19	1	Coil for undervoltage device, d-c
18	734	ALL	ALL	6174599G2	6174599G2	6174599G2	3	Current trip coil, 3-ampere, a-c
18	735	ALL	ALL	6174599G6	6174599G6	6174599G6	1	Capacitor trip coil, 230-volt, a-c
19	778	ALL	ALL	6275017G19	6275017G19	6275017G19	1	Coil for control device, 125-volt, d-c
19	778	ALL	ALL	6275017G20	6275017G20	6275017G20	1	Coil for control device, 250-volt, d-c
19	778	ALL	ALL	6275017G34	6275017G34	6275017G34	1	Coil for control device, 230-volt, a-c

TYPE AM-13.8 AIR CIRCUIT BREAKERS

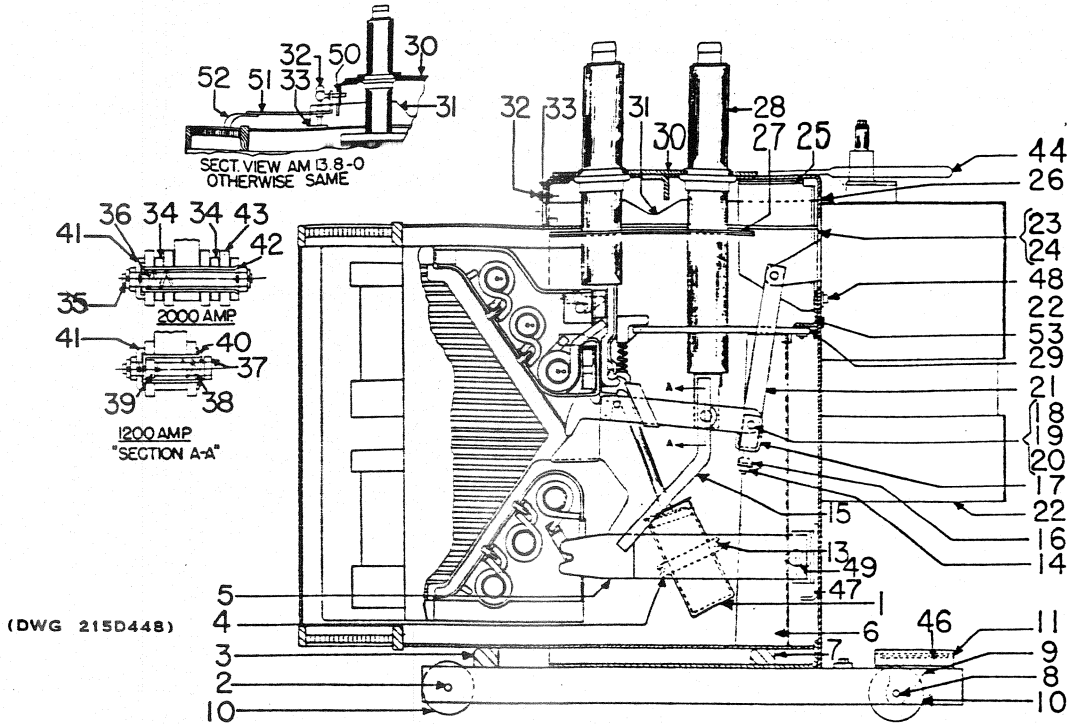

Fig. 2. Cross-section view of breaker
PARTS REFERENCED IN FIG. 2

Ref. No.	MVA	AMP	Catalog Number for			No. Req.	Description
			AM-13.8 (MVA)-0	AM-13.8 (MVA)-1	AM-13.8 (MVA)-2		
1	ALL	ALL	263B292P2	263B292P2	263B292P2	3	Booster cylinder
2	ALL	ALL	6477427BAP14	6477427BAP14	6477427BAP14	2	Axle
3	ALL	ALL	6597293AA	6597293AA	6597293AA	1	Box barrier support and guide
4	ALL	ALL	258C680P6	258C680P6	258C680P6	6	Support for arc chute
5	ALL	ALL	6442375	6442375	6442375	6	Coupling for arc chute support
6	ALL	ALL	6291394G2	9915624G1	9915624G1	3	Front vertical barrier
7	ALL	ALL	366A606G2	366A606G2	366A606G2	1	Support and guide for box barrier
8	ALL	ALL	6597298P2	6597298P2	6597298P2	2	Axle
9	ALL	ALL	6597296P4	6597296P4	6597296P4	2	Fork
10	ALL	ALL	6597294P1	6597294P1	6597296P7	4	Wheel
11	ALL	ALL	6591777AA	6591777AA	236C768G5	1	Support and wheel base (left-hand)
11	ALL	ALL	6591778AA	6591778AA	236C768G5	1	Support and wheel base (right-hand)
12	ALL	ALL	6443613	*	*	3	Support for front vertical barrier
13	ALL	ALL	6477414ACP13	6477414ACP13	6477414ACP13	12	Stud
14	ALL	ALL	6477429P4	6477429P4	6477429P4	2	Nut
15	ALL	ALL	6591800P1	6591800P1	6591800P1	3	Connection bar
16	ALL	ALL	Δ	Δ	Δ	3	Nut, jam
17	ALL	ALL	281B708P5	281B708P5	281B708P5	3	Yoke
18	ALL	ALL	383A926AF39	383A926AF39	383A926AF39	3	Pin
19	ALL	ALL	6477424P6	6477424P6	6477424P6	6	Retaining ring
20	ALL	ALL	6477400P6	6477400P6	6477400P6	12	Washer (anti-friction)
21	ALL	ALL	281B708G1	281B708G1	281B708G1	3	Yoke and operating rod assembly
22	ALL	ALL	†	†	†	1	Cover for mechanism
23	{150, 250, 500B}	ALL	6591655AA	6591655AA	6591655AA	1	Gusset (left-hand)
23	{150A, 250A, 500A, 500AB}	ALL	6591945AA	6591945AA	6591945AA	1	Gusset (left-hand)

* Not furnished in this breaker.

Δ On application.

† Identified only from breaker nameplate data.

TYPE AM-13.8 AIR CIRCUIT BREAKERS

GEF-3875C

PARTS REFERENCED IN FIG. 2 (CONT'D)

Ref. No.	MVA	AMP	Catalog Number for			No. Req.	Description
			AM-13.8(MVA)-0	AM-13.8(MVA)-1	AM-13.8(MVA)-2		
24	150, 250, 500, 500B	ALL	6591656AA	6591656AA	6591656AA	1	Gusset (right-hand)
24	{150A, 250A, 500A, 500AB}	ALL	6591946AA	6591946AA	6591946AA	1	Gusset (right-hand)
25	150, 250, 500, 500B	ALL	6557889P1	6557889P1	6557889P1	8	Shim
25	{150A, 250A, 500A, 500AB}	ALL	6557889P2	6557889P2	6557889P2	8	Shim
26	150, 250, 500, 500B	1200	215D428G3	215D428G3	215D428G3	1	Breaker frame
26	150, 250, 500, 500B	2000	215D428G4	215D428G4	215D428G4	1	Breaker frame
26	{150A, 250A, 500A, 500AB}	1200	236C727G3	236C727G3	236C727G3	1	Breaker frame
26	{150A, 250A, 500A, 500AB}	2000	236C727G4	236C727G4	236C727G4	1	Breaker frame
27	150, 250, 500	1200	6591811P1	174V399P1	174V399P1	6	Upper horizontal barrier
27	{150A, 250A, 500A, 500AB}	2000	6591811P2	174V399P2	174V399P2	6	Upper horizontal barrier
28	{150, 150A, 250, 250A, 500, 500A}	1200	236C766G4	236C766G4	236C766G4	3	Bushing (long)
28	500B, 500AB	1200	236C766G4	236C766G4	236C766G4	3	Bushing (long)
28	ALL	2000	236C766G5	236C766G5	236C766G5	3	Bushing (long)
29	ALL	1200	6591801P1	374A299G1	374A299G1	6	Lower horizontal barrier
29	ALL	2000	6591801P3	374A299G2	374A299G2	6	Lower horizontal barrier
30	ALL	ALL	6592323P2	6592323P2	6592323P2	1	Top plate
31	ALL	ALL	6557290G1	6557290G1	6557290G1	1	Barrier (right side)
†31A	ALL	ALL	6557289G1	6557289G1	6557289G1	1	Barrier (left side)
32	ALL	ALL	6443614	6477411AAP11	6477411AAP11	6	Screw
33	ALL	ALL	6442362	175V536	175V536	3	Block
†34	ALL	1200	6442246	*	*	6	Spacer
34	ALL	2000	6442246	6442246	6442246	6	Spacer
35	500B, 500AB	1200	6442258	*	*	3	Stud
35	ALL	2000	6442258	6442258	6442258	3	Stud
36	ALL	2000	369A407	369A407	369A407	3	Spring
37	ALL	1200	414A106P4	414A106P4	414A106P4	3	Bolt
38	ALL	1200	421A239	421A239	421A239	3	Spring
40	§	1200	6442371	6442371	6442371	3	Bearing
41	{150, 150A, 250, 250A, 500, 500A}	1200	6441617	6441617	6441617	3	Washer
41	500B, 500AB	1200	6443653	6441617	6441617	3	Washer
41	ALL	2000	6443653	6443653	6443653	3	Washer
42	500B, 500AB	1200	6442257	*	*	3	Bearing
42	ALL	2000	6442257	6442257	6442257	3	Bearing
43	500B, 500AB	1200	6441630	*	*	3	Washer
43	ALL	2000	6441630	6441630	6441630	3	Washer
44	ALL	ALL	6591815P1	6591815P1	6591815P1	1	Handle
46	{150A, 250A, 500A, 500AB}	ALL	6445056	6445056	6445056	2	Spacer
47	ALL	ALL	258C680P7	258C680P7	258C680P7	6	Support
48	ALL	ALL	6557888P1	6557888P1	6557888P1	2	Pin
49	ALL	ALL	*	258C614P5	258C614P5	3	Block
50	ALL	ALL	6445004P1	*	*	2	Clamp for side barrier
51	ALL	ALL	6597442AA	*	*	3	Bracket
52	ALL	ALL	6591804P1	*	*	3	Catch
53	ALL	ALL	6597422AA	*	*	3	Bolting plate
56	ALL	ALL	6443502	*	*	6	Nut
57	ALL	ALL	6597420P2	*	*	6	Stud
58	ALL	ALL	6597421P1	*	*	6	Nut

* Not furnished in this breaker.

† Not illustrated in Fig. 2 for 1200-ampere breaker.

§ All types except - 500B and - 500AB.

TYPE AM-13.8 AIR CIRCUIT BREAKERS

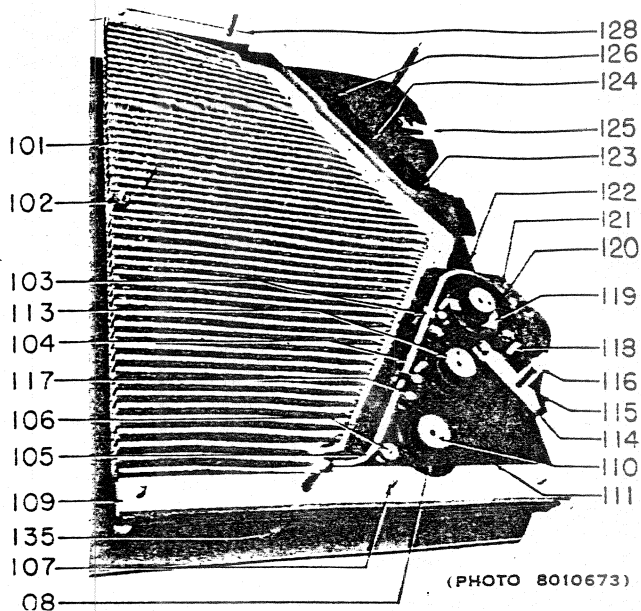

(PHOTO 8010673)

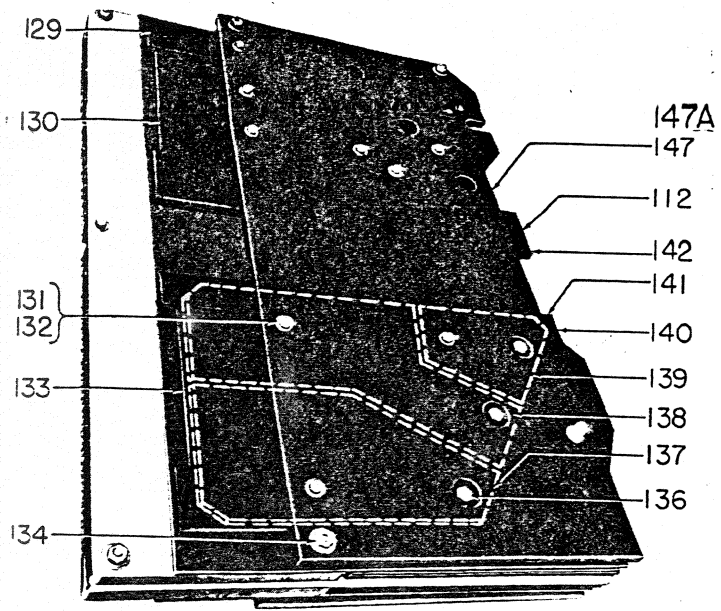

(PHOTO 8011268)

Fig. 3. Arc chute assembly with side cover removed

Fig. 3A. Complete arc chute assembly (Ref. 100)

PARTS REFERENCED IN FIGS. 3 and 3A.

Fig. No.	Ref. No.	MVA	AMP	Catalog Number for			No. Req.	Description
				AM-13.8(MVA)-0	AM-13.8(MVA)-1	AM-13.8(MVA)-2		
3A	100	ALL	ALL	215D414G1	215D414G1	215D414G1	3	Arc chute asm, complete
3	101	ALL	ALL	264B100G7	264B100G7	264B100G7	3	Arc chute sides
3	102	ALL	ALL	6445050P3	6445050P3	6445050P3	3	Spacer
3	103	ALL	ALL	6442365P2	6442365P2	6442365P2	3	Spacer for arc runner
3	104	ALL	ALL	6591756AB	6591756AB	6591756AB	6	Spacer for lower arc runner
3	105	ALL	ALL	6591755AB	6591755AB	6591755AB	3	Arc runner (intermediate)
3	106	ALL	ALL	414752	414752	414752	3	Arc runner (lower)
3	107	ALL	ALL	6445057	6445057	6445057	84	Washer
3	108	ALL	ALL	6591765AA	6591765AA	6591765AA	15	Screw
3	109	ALL	ALL	6442390P1	6442390P1	6442390P1	6	Lower coil
3	110	ALL	ALL	6441722P1	6441722P2	6441722P2	3	Lower spacer for arc chute
3	111	ALL	ALL	6593318P1	6593318P1	6593318P1	9	Core
3A	112	ALL	ALL	6557249P1	6557249P1	6557249P1	6	Lower coil support
3	113	ALL	ALL	6441638	6441638	6441638	6	Insulation for pole piece
3	114	ALL	ALL	6591769AA	366A631G1	366A631G1	9	Insulation tube for core
3	115	ALL	ALL	6442377	6442377	6442377	3	Spacer for lower arc runner
3	116	ALL	ALL	6477401DAP8	6477401DAP13	6477401DAP13	3	Barrier for lower arc runner
3	117	ALL	ALL	6597401P1	6597401P1	6597401P1	6	Spacer
3	118	ALL	ALL	6591812P11	6591812P11	6591812P11	18	Spring washer
3	119	ALL	ALL	6591767AA	6591767AA	6591767AA	9	Spacer
3	120	ALL	ALL	6591764AB	6591764AB	6591764AB	3	Lower coil (upper)
3	121	ALL	ALL	6592346P2	6592346P2	6592346P2	3	Arc runner (upper)
3	122	ALL	ALL	6593319P1	6593319P1	6593319P1	6	Lower insulation
3	123	ALL	ALL	247C906P1	247C906P1	247C906P1	6	Shield
3	124	ALL	ALL	247C906P2	247C906P2	247C906P2	6	Upper pole piece (lower)
3	125	ALL	ALL	6591481P1	6591481P1	6591481P1	6	Upper pole piece (intermediate)
3	126	ALL	ALL	247C906P3	247C906P3	247C906P3	6	Latch
3	127	ALL	ALL	6593321P2	6593321P2	6593321P2	6	Upper pole piece (upper)
3	128	ALL	ALL	6442389P1	6442389P1	6442389P1	6	Brace
3	129	ALL	ALL	6557249P3	6557249P3	6557249P3	3	Upper spacer for arc chute
3A	130	ALL	ALL	6593319P1	6593319P1	6593319P1	12	Insulation for pole piece
3A	131	ALL	ALL	6445051P1	6445051P1	6445051P1	6	Insulation for pole piece
3A	132	ALL	ALL	6445072P3	6445072P3	6445072P3	48	Spacer
							54	Stud

† Not illustrated.

TYPE AM-13.8 AIR CIRCUIT BREAKERS

GEF-3875C

PARTS REFERENCED IN FIG. 3 and 3A (CONT'D)

Fig. No.	Ref. No.	MVA	AMP	Catalog Number for			No. Req.	Description
				AM-13.8(MVA)-0	AM-13.8(MVA)-1	AM-13.8(MVA)-2		
3A	133	ALL	ALL	6442380P4	6442380P4	6442380P4	6	Insulation for pole piece
3A	134	ALL	ALL	6477414ACP7	6477414ACP13	6477414ACP13	9	Stud
3A	136	ALL	ALL	1404030	1404030	1404030	18	Washer
3A	137	ALL	ALL	247C907P1	247C907P1	247C907P1	6	Lower pole piece (lower)
3A	138	ALL	ALL	247C907P2	247C907P2	247C907P2	6	Lower pole piece (intermediate)
3A	139	ALL	ALL	247C907P3	247C907P3	247C907P3	6	Lower pole piece (upper)
3A	140	ALL	ALL	6557249P2	6557249P2	6557249P2	6	Insulation for pole piece
3A	141	ALL	ALL	6442380P1	6442380P1	6442380P1	6	Insulation for pole piece
3A	142	ALL	ALL	6442380P2	6442380P2	6442380P2	6	Insulation for pole piece
3A	147	ALL	ALL	384A324G1	384A324G1	384A324G1	3	Brace assembly (left side)
3A	147A	ALL	ALL	384A324G2	384A324G2	384A324G2	3	Brace assembly (right side)
3	148	ALL	ALL	104A2403P1	104A2403P1	104A2403P1	3	Shim

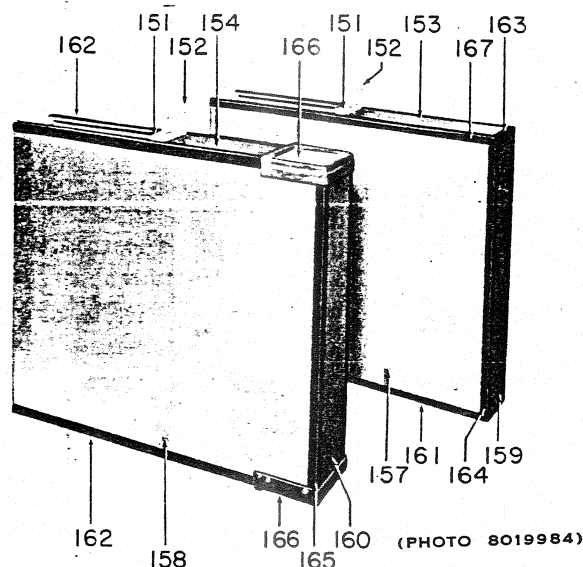

Fig. 4. Complete box barriers (Ref. 150)

PARTS REFERENCED IN FIG. 4

Ref. No.	MVA	AMP	Catalog Number for			No. Req.	Description
			AM-13.8(MVA)-0	AM-13.8(MVA)-1	AM-13.8(MVA)-2		
150	150, 250	ALL	265C176G2	265C176G2	265C176G2	3	Box barrier, complete
150	500, 500B	ALL	265C176G1	265C176G1	265C176G1	3	Box barrier, complete
151	ALL	ALL	175V537P1	175V537P1	175V537P1	3	Block
*152	ALL	ALL	265B151P28	265B151P28	261B151P28	3	Catch
153	150, 250	ALL	175V210P1	175V210P1	175V210P1	3	Top barrier
154	500, 500B	ALL	6557908P2	6557908P2	6557908P2	3	Top barrier
†155	150, 250	ALL	175V239	175V239	175V239	3	Bottom barrier
†156	500, 500B	ALL	6557907P4	6557907P4	6557907P4	3	Bottom barrier
157	150, 250	ALL	175V237P1	175V237P1	175V237P1	6	Side barrier
158	500, 500B	ALL	366A608P1	366A608P1	366A608P1	6	Side barrier
159	150, 250	ALL	175V212	175V212	175V212	3	Back barrier
160	500, 500B	ALL	6557907P3	6557907P3	6557907P3	3	Back barrier
161	150, 250	ALL	366A628P1	366A628P1	366A628P1	12	Corner post
162	500, 500B	ALL	6557906P4	6557906P4	6557906P4	12	Corner post
163	150, 250	ALL	366A628P2	366A628P2	366A628P2	6	Corner post
164	150, 250	ALL	366A628P3	366A628P3	366A628P3	6	Corner post
165	500, 500B	ALL	6557906P5	6557906P5	6557906P5	6	Corner post
166	500, 500B	ALL	264B171G2	264B171G2	264B171G2	6	Muffler
167	ALL	ALL	176V937	176V937	176V937	72	Rivet

* Order Ref. No. 152 when ordering barriers for the "-0" breakers.

† Not illustrated.

TYPE AM-13.8 AIR CIRCUIT BREAKERS

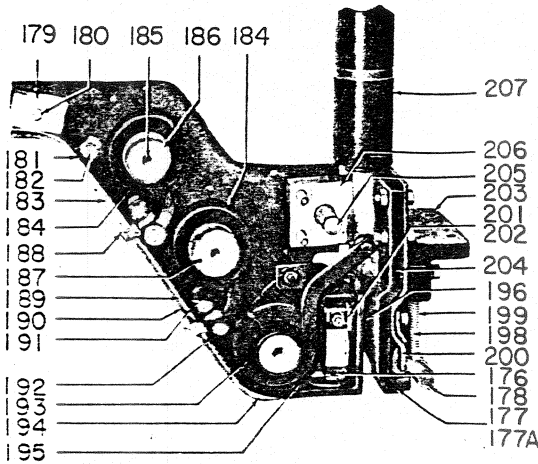

(PHOTO 8014741)

Fig. 5. Rear bushing and upper arc runner assembly with side insulation removed

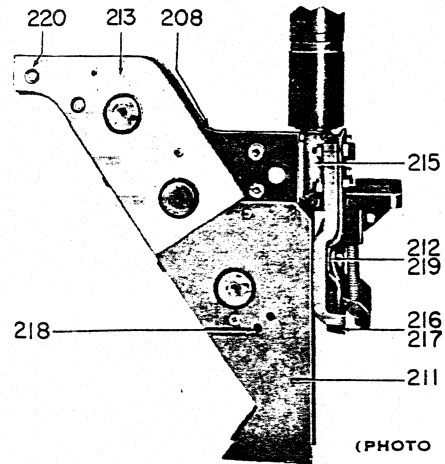

(PHOTO 8014742)

Fig. 5A. Complete rear bushing and upper arc runner assembly (Ref. 175)

PARTS REFERENCED IN FIG. 5 and 5A.

Fig. No.	Ref. No.	MVA	AMP	Catalog Number for			No. Req.	Description
				AM-13.8(MVA)-0	AM-13.8(MVA)-1	AM-13.8(MVA)-2		
5A	175	{150, 150A, 250, 250A, 500, 500A}	1200	175L205G1	175L205G7	175L205G7	3	Bushing and arc runner assembly complete
5A	175	500B, 500AB	1200	175L205G6	175L205G9	175L205G9	3	Bushing and arc runner assembly complete
5A	175	ALL	2000	175L205G2	175L205G8	175L205G8	3	Bushing and arc runner assembly complete
5	176	ALL	ALL	6514946G2	383A903G1	383A903G1	3	Secondary contact fingers
5	177	ALL	ALL	389A616P6	6445087P1	6445087P1	3	Buffer
5	177A	{150, 150A, 250, 250A, 500, 500A}	1200	389A616G1	6557243P1	6557243P1	6	Clamp for buffer
5	177A	500B, 500AB	1200	389A616G2	6557243P2	6557243P2	6	Clamp for buffer
5	177A	ALL	2000	389A616G2	6557243P2	6557243P2	6	Clamp for buffer
5	178	{150, 150A, 250, 250A, 500, 500A}	1200	236C791P8	236C791P8	236C791P8	12	Primary contact fingers
5	178	500B, 500AB	1200	236C791P8	236C791P8	236C791P8	24	Primary contact fingers
5	178	ALL	2000	236C791P8	236C791P8	236C791P8	24	Primary contact fingers
5	179	ALL	ALL	175V539P1	175V539P1	175V539P1	3	Spacer
5	180	ALL	ALL	6597448P1	6597448P1	6597448P1	6	Screw
5	181	ALL	ALL	6442369	6442369	6442369	3	Arc runner filler plate (upper)
5	182	ALL	ALL	6477401AAP29	6477401AAP29	6477401AAP29	6	Spacer
5	183	ALL	ALL	6591755AB	6591755AB	6591755AB	3	Upper arc runner (top)
5	184	ALL	ALL	6591770AA	6591770AA	6591770AA	6	Coil no. 2 and 3
5	185	ALL	ALL	432249	432249	432249	18	Washer
5	186	ALL	ALL	6441638	6441638	6441638	9	Insulation tube for core
5	187	ALL	ALL	6441722P1	6441722P1	6441722P1	9	Core
5	188	ALL	ALL	6442370P2	6442370P2	6442370P2	6	Spacer for arc runner
5	189	ALL	ALL	6442368	6442368	6442368	3	Arc runner filler plate (intermediate)
5	190	ALL	ALL	6591756AB	6591756AB	6591756AB	3	Upper arc runner (intermediate)
5	191	ALL	ALL	6597401P1	6597401P1	6597401P1	18	Spring washer
5	192	ALL	ALL	6591812P5	6591812P5	6591812P5	24	Spacer
5	193	ALL	ALL	456A302G1	456A302G1	456A302G1	3	Coil no. 1
5	194	ALL	ALL	6591750AB	6591750AB	6591750AB	3	Upper arc runner (lower)

TYPE AM-13.8 AIR CIRCUIT BREAKERS

GEF-3875C

PARTS REFERENCED IN FIG. 5 and 5A (CONT'D)

Fig. No.	Ref. No.	MVA	AMP	Catalog Number for			No. Req.	Description
				AM-13.8(MVA)-0	AM 13.8(MVA)-1	AM-13.8(MVA)-2		
5	195	ALL	ALL	175V230	175V230	175V230	3	Secondary contact barrier
5	196	ALL	ALL	6445085	6445085	6445085	3	Insulation
5	198	150, 150A, 250, 250A, 500, 500A	1200	6509787	6509787	6509787	12	Contact spring
5	198	500B, 500AB	1200	6509787	6509787	6509787	24	Contact spring
5	198	ALL	2000	6509787	6509787	6509787	24	Contact spring
5	190	150, 150A, 250, 250A, 500, 500A	1200	6442357	6442357	6442357	12	Spring guide
5	199	500B, 500AB	1200	6442357	6442357	6442357	24	Spring guide
5	199	ALL	2000	6442357	6442357	6442357	24	Spring guide
5	200	150, 150A, 250, 250A, 500, 500A	1200	258C666P5	258C666P5	258C666P5	3	Retainer for primary contact finger
5	200	500B, 500AB	1200	236C791P3	236C791P3	236C791P3	3	Retainer for primary contact finger
5	200	ALL	2000	236C791P3	236C791P3	236C791P3	3	Retainer for primary contact finger
5	201	ALL	ALL	6591812P15	6591812P15	6591812P15	3	Bushing
5	202	ALL	ALL	6441602	6441602	6441602	3	Nut
5	203	150, 150A, 250, 250A, 500, 500A	1200	6592330P2	6592330P2	6592330P2	3	Spring retainer
5	203	500B, 500AB	1200	6592331P2	6592331P2	6592331P2	3	Spring retainer
5	203	ALL	2000	6592331P2	6592331P2	6592331P2	3	Spring retainer
5	204	150, 150A, 250, 250A, 500, 500A	1200	383A904G1	383A904G1	383A904G1	3	Contact support assembly
5	204	500B, 500AB	1200	383A904G2	383A904G2	383A904G2	3	Contact support assembly
5	204	ALL	2000	383A904G2	383A904G2	383A904G2	3	Contact support assembly
5	205	ALL	ALL	176V932	176V932	176V932	3	Pin
5	206	150, 150A, 250, 250A, 500, 500A	1200	6591737P1	6591737P1	6591737P1	3	Spacer
5	206	500B, 500AB	1200	6591737P2	6591737P1	6591737P1	3	Spacer
5	206	ALL	2000	6591737P2	6591737P2	6591737P2	3	Spacer
5	207	150, 150A, 250, 250A, 500, 500A	1200	236C765G4	236C765G4	236C765G4	3	Bushing (short)
5	207	500B, 500AB	1200	265C187G8	265C187G8	265C187G8	3	Bushing (short)
5	207	ALL	2000	236C765G5	236C765G5	236C765G5	3	Bushing (short)
5A	208	ALL	ALL	6593317P2	6593317P2	6593317P2	6	Coil support
†	209	ALL	ALL	414752	*	*	12	Washer
†	209	ALL	ALL	*	414752	414752	36	Washer
†	210	ALL	ALL	6597402P1	6597402P1	6597402P1	3	Cover
5A	211	ALL	ALL	6592336P1	6592336P2	6592336P2	6	Upper runner insulation (bottom)
5A	212	ALL	2000	6591738P1	6591738P1	6591738P1	3	Jumper
5A	212	ALL	1200	6591738P1	6591738P1	6591738P1	3	Jumper
5A	213	ALL	ALL	6591742P1	6591742P1	6591742P1	6	Upper runner insulation (top)
5A	215	ALL	ALL	6442356	*	*	3	Brace
5A	216	ALL	ALL	176V939P2	176V939P2	176V939P2	12	Screw
5A	217	ALL	ALL	6477430P3	6477430P3	6477430P3	6	Pin
5A	218	ALL	ALL	*	175V232	175V232	3	Coil protector
5A	219	150, 150A, 250, 250A, 500, 500A	1200	6442352	6442352	6442352	3	Finger retainer
5A	219	500B, 500AB	1200	236C791P5	236C791P5	236C791P5	3	Finger retainer
5A	219	ALL	2000	366A688P4	366A688P4	366A688P4	3	Finger retainer
5A	220	ALL	ALL	175V245	175V245	175V245	6	Washer

† Not illustrated.

* Not furnished in this breaker.

TYPE AM-13.8 AIR CIRCUIT BREAKERS

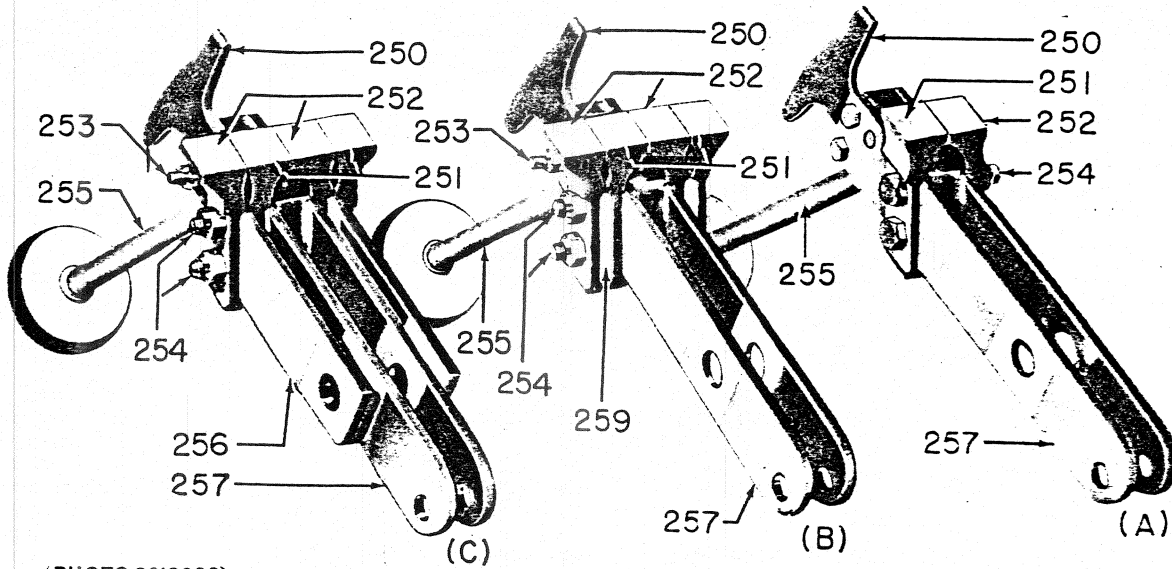

(PHOTO 8019922)

Fig. 6. Contact arm assembly (Ref. 249)

PARTS REFERENCED IN FIG. 6

Fig. No.	Ref. No.	MVA	AMP	Catalog Number for			No. Req.	Description
				AM-13.8(MVA)-0	AM-13.8(MVA)-1	AM-13.8(MVA)-2		
6(A)	249	{150, 150A, 250, 250A, 500, 500A}	1200	236C792G12	236C792G12	236C792G12	3	Contact arm assembly complete
6(B)	249	500B, 500AB	1200	236C792G13	236C792G14	236C792G14	3	Contact arm assembly complete
6(C)	249	ALL	2000	236C792G13	236C792G13	236C792G13	3	Contact arm assembly complete
6	250	ALL	ALL	802B742G3	802B742G3	802B742G3	3	Arcing tip
6	251	{150, 150A, 250, 250A, 500, 500A}	1200	6591644P7	6591644P7	6591644P7	3	Primary contact
6	251	500B, 500AB	1200	6591644P7	6591644P7	6591644P7	6	Primary contact
6	251	ALL	2000	6591644P7	6591644P7	6591644P7	6	Primary contact
6	252	{150, 150A, 250, 250A, 500, 500A}	1200	6591644P8	6591644P8	6591644P8	6	Primary contact
6	252	500B, 500AB	1200	6591644P8	6591644P8	6591644P8	6	Primary contact
6	252	ALL	2000	6591644P8	6591644P8	6591644P8	6	Primary contact
6	253	ALL	ALL	6477412AAP21	6477412AAP21	6477412AAP21	6	Bolt
6	254	{150, 150A, 250, 250A, 500, 500A}	1200	6477412AAP17	6477412AAP17	6477412AAP17	12	Bolt
6	254	ALL	2000	6477412ABP14	6477412ABP14	6477412ABP14	12	Bolt
6	254	500B, 500AB	1200	6477412ABP8	6477412ABP8	6477412ABP8	12	Bolt
6	255	ALL	ALL	236C792G15	236C792G15	236C792G15	3	Tube assembly
6	256	500B, 500AB	1200	258C666P7	258C666P7	258C666P7	6	Contact arm
6	256	ALL	2000	258C666P6	258C666P6	258C666P6	6	Contact arm
6	257	ALL	ALL	258C666P7	258C666P7	258C666P7	6	Contact arm
6	259	500B, 500AB	1200	258C619P2	258C619P2	258C619P2	6	Spacer

§ When Ref. No. 255 is ordered, Ref. No. 259 also is required.

TYPE AM-13.8 AIR CIRCUIT BREAKERS

GEF-3875C

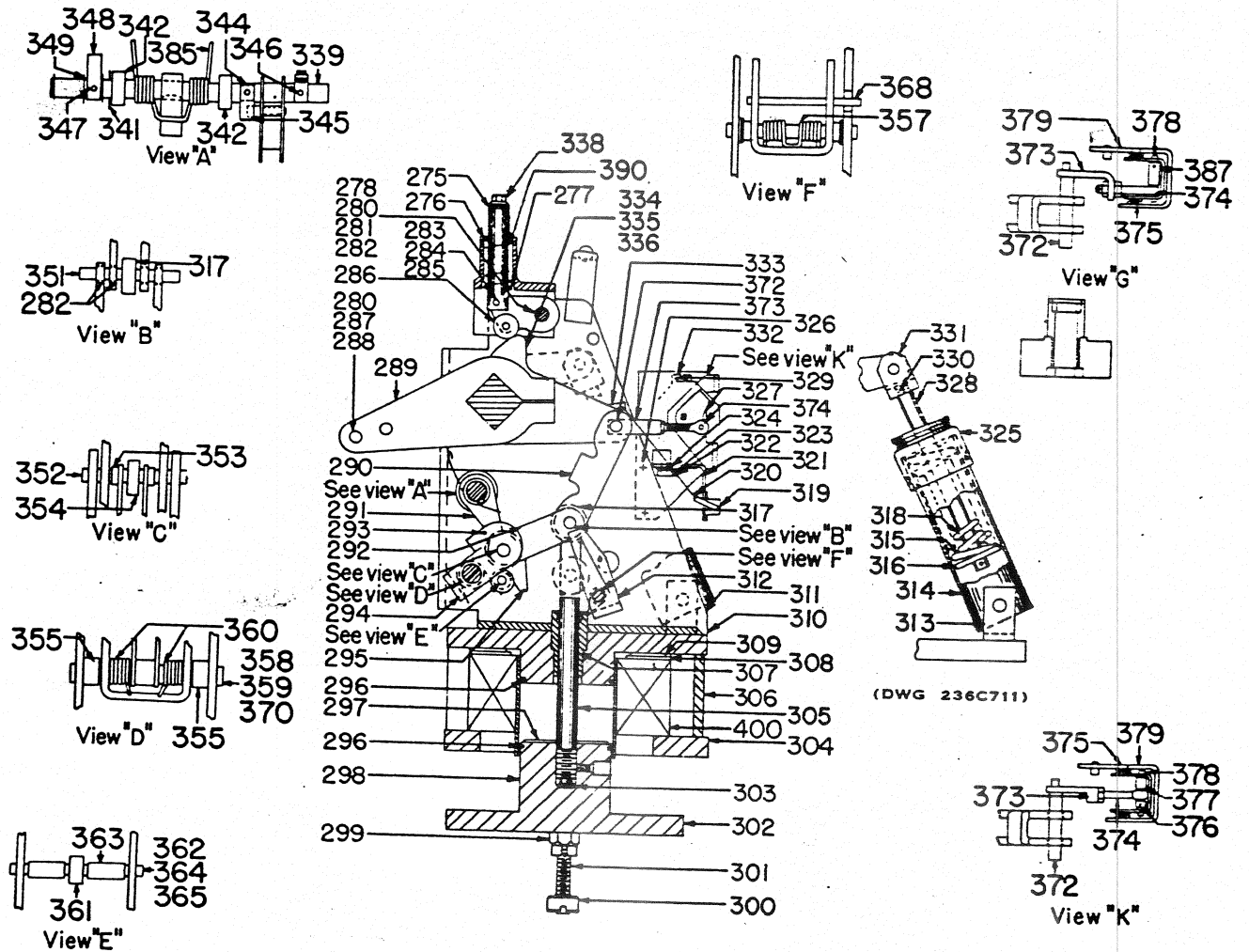

Fig. 7. Cross-section of mechanism for type AM-13.8-0 breaker

PARTS REFERENCED IN FIG. 7 and 8

Fig. No.	Ref. No.	MVA	AMP	Catalog Number for			No. Req.	Description
				AM-13.8(MVA)-0	AM-13.8(MVA)-1	AM-13.8(MVA)-2		
7, 8	275	ALL	ALL	6442255P1	6442255P1	6442255P1	1	Interlock plunger
7, 8	276	ALL	ALL	6597271AA	264B133G1	264B133G1	1	Interlock bracket
7, 8	277	ALL	ALL	6443715	6443715	6443715	1	Washer
7, 8	278	ALL	ALL	6477427JAP4	6477427JAP4	6477427JAP4	1	Pin
7, 8	280	ALL	ALL	6477400P6	6477400P6	6477400P6	40	Washer
7, 8	281	ALL	ALL	6597228P1	6597228P1	6597228P1	2	Crank
7, 8	282	ALL	ALL	6370566P55	*	*	16	Bushing
7, 8	282	150, 250, 500, 500B	ALL	*	6370566P55	6370566P55	14	Bushing
7, 8	282	150A, 250A, 500A, 500AB	ALL	*	6370566P55	6370566P55	12	Bushing
7, 8	283	ALL	ALL	6477427AAP9	6477427AAP9	6477427AAP9	2	Pin
7, 8	284	ALL	ALL	6477424P4	6477424P4	6477424P4	9	Retaining ring
7, 8	285	ALL	ALL	6477400P4	6477400P18	6477400P18	17	Washer
7, 8	286	ALL	ALL	236C787P14	236C787P14	236C787P14	1	Roller
7, 8	287	ALL	ALL	383A926AFP39	383A926AFP39	383A926AFP39	3	Pin
7, 8	288	ALL	ALL	6477424P6	6477424P6	6477424P6	18	Retaining ring
7, 8	289	ALL	ALL	6591635P2	6591635P2	6591635P2	6	Crank

* Not furnished in this breaker.

TYPE AM-13.8 AIR CIRCUIT BREAKERS

PARTS REFERENCED IN FIG. 7 and 8 (CONT'D)

Fig. No.	Ref. No.	MVA	AMP	Catalog Number for			No. Req.	Description
				AM-13.8(MVA)-0	AM-13.8(MVA)-1	AM-13.8(MVA)-2		
7,8	290	ALL	ALL	6591636P1	6591636P1	6591636P1	1	Link
7,8	291	ALL	ALL	258C608P7	258C608P7	258C608P7	1	Latch
7,8	292	ALL	ALL	6442285	6442285	6442285	2	Link
7,8	293	ALL	ALL	6445063	6445063	6445063	1	Pin
7,8	294	ALL	ALL	6591711P1	6591711P1	6591711P1	1	Link
7,8	295	ALL	ALL	6591953P1	6591953P1	6591953P1	1	Guide for latch
7,8	296	ALL	ALL	6591632P1	6591632P1	6591632P1	2	Piston ring
7,8	297	ALL	ALL	6477879P2	6477879P7	6477879P7	1	Washer
7,8	298	ALL	ALL	6591630P1	6591630P1	6591630P1	1	Armature
7,8	299	ALL	ALL	6591388P20	6591388P20	6591388P20	2	Linking plate
7,8	300	ALL	ALL	6443758	6443758	6443758	2	Nut
7,8	301	ALL	ALL	6443757	6443757	6443757	2	Stud
7,8	302	ALL	ALL	6441611P1	6441611P1	6441611P1	1	Armature plate
7,8	303	ALL	ALL	6370572P9	6370572P9	6370572P9	8	Washer
7,8	304	ALL	ALL	6441635P3	6441635P3	6441635P3	1	Plate
7,8	305	ALL	ALL	236C796P6	236C796P6	236C796P6	1	Plunger
7,8	306	ALL	ALL	6591361P1	6591361P1	6591361P1	1	Solenoid pot
7,8	307	ALL	ALL	236C795P4	236C795P4	236C795P4	1	Pole piece
7,8	307A	ALL	ALL	236C796P12	236C796P12	236C796P12	1	Guide
7,8	308	ALL	ALL	374A208P1	374A208P1	374A208P1	1	Washer
7,8	309	ALL	ALL	6477417BAP7	6477417BAP7	6477417BAP7	1	Washer
7,8	310	ALL	ALL	6591640P1	6591640P1	6591640P1	1	Bottom plate
7,8	311	ALL	ALL	6593208AA	236C704G1	236C704G1	1	Frame
7,8	312	ALL	ALL	258C609P1	258C609P1	258C609P1	1	Prop
7,8	313	ALL	ALL	6591733	174V389P1	174V389P1	2	Bracket
7,8	314	ALL	ALL	6442261	387A368G1	387A368G1	2	Spring retainer
7,8	315	ALL	ALL	6551703	369A468	369A468	2	Spring (opening out-side)
7,8	316	ALL	ALL	6442263	174V391P1	174V391P1	2	Washer
7,8	317	ALL	ALL	258C609P5	258C609P5	258C609P5	1	Roller
7,8	318	ALL	ALL	6551704	369A411	369A411	2	Spring (opening out-side)
7,8	319	ALL	ALL	6192382ABP1	6192382ABP1	6192382ABP1	1	Veeder counter
7,8	320	ALL	ALL	6551742P1	6551742P1	6551742P1	1	Spring for counter
7,8	321	ALL	ALL	6442346	6442346	6442346	1	Bracket for counter
7,8	322	ALL	ALL	6442345	6442345	6442345	1	Bracket for counter
7,8	323	ALL	ALL	6477412ABP2	6477412ABP2	6477412ABP2	2	Screw
7,8	324	ALL	ALL	6440521P2	6440521P2	6440521P2	2	Spring for counter bracket
7	325	ALL	ALL	6442262	*	*	2	Cap
7,8	326	ALL	ALL	6477412ABP1	6477412ABP1	6477412ABP1	2	Screw
7,8	327	ALL	ALL	6592337P1	6592337P1	6592337P1	1	Crank for auxiliary switch
7,8	328	ALL	ALL	6442266	366A618G1	366A618G1	2	Rod
7,8	329	ALL	ALL	6445064	6445064	6445064	2	Screw
7,8	330	ALL	ALL	6477415P21	6477427LAP1	6477427LAP1	2	Pin
7,8	331	ALL	ALL	6591628P1	174V397P1	174V397P1	2	Clevis
7,8	332	ALL	ALL	415A489G1	415A489G1	415A489G1	1	Auxiliary switch
7,8	333	ALL	ALL	6597455P1	6597455P1	6597455P1	1	Operating arm
7,8	334	ALL	ALL	6591715P1	6591715P1	6591715P1	2	Crank
7,8	335	ALL	ALL	6370566P59	6370566P59	6370566P59	2	Bushing
7,8	336	ALL	ALL	6597454P1	6597454P1	6597454P1	2	Nut
7,8	338	ALL	ALL	6443713	6443713	6443713	1	Screw
7,8	339	{150, 250, 500, 500B}	ALL	6591707P1	6557012P1	6557012P1	1	Shaft for latch
7,8	339	{150A, 250A, 500A, 500AB}	ALL	6557012P1	6557012P1	6557012P1	1	Shaft for latch
7	341	ALL	ALL	6477400P8	6477400P8	6477400P8	20	Washer
7,8	342	ALL	ALL	414A111P1	414A111P1	414A111P1	2	Ball bearing
7,8	344	ALL	ALL	6445071	6445071	6445071	1	Spacer
7,8	345	ALL	ALL	6443686	6443686	6443686	1	Current trip bar
7,8	346	ALL	ALL	6597225P1	6597225P1	6597225P1	1	Operating bar for cut-off switch
7,8	347	ALL	ALL	6477412AAP22	6477412AAP22	6477412AAP22	1	Screw
7,8	348	ALL	ALL	6591706P1	6591706P1	6591706P1	1	Stop bar
7,8	349	ALL	ALL	6477424P29	6477424P29	6477424P29	6	Retainer ring
7,8	351	ALL	ALL	6442227	6442227	6442227	1	Prop pin
7,8	352	ALL	ALL	6477427CAP7	6477427CAP7	6477427CAP7	1	Pin
7,8	353	ALL	ALL	6477501CAP29	6477401CAP29	6477401CAP29	2	Spacer
7,8	354	ALL	ALL	6477418BAP5	6477418BAP5	6477418BAP5	1	Needle bearing
7,8	355	ALL	ALL	6477401DAP32	6477401DAP32	6477401DAP32	2	Spacer
7,8	357	ALL	ALL	6477097	6477097	6477097	1	Prop spring
7,8	358	ALL	ALL	6477427EAP9	6477427EAP9	6477427EAP9	1	Pin

* Not furnished in this breaker.

† Not illustrated.

TYPE AM-13.8 AIR CIRCUIT BREAKERS

GEF-3875C

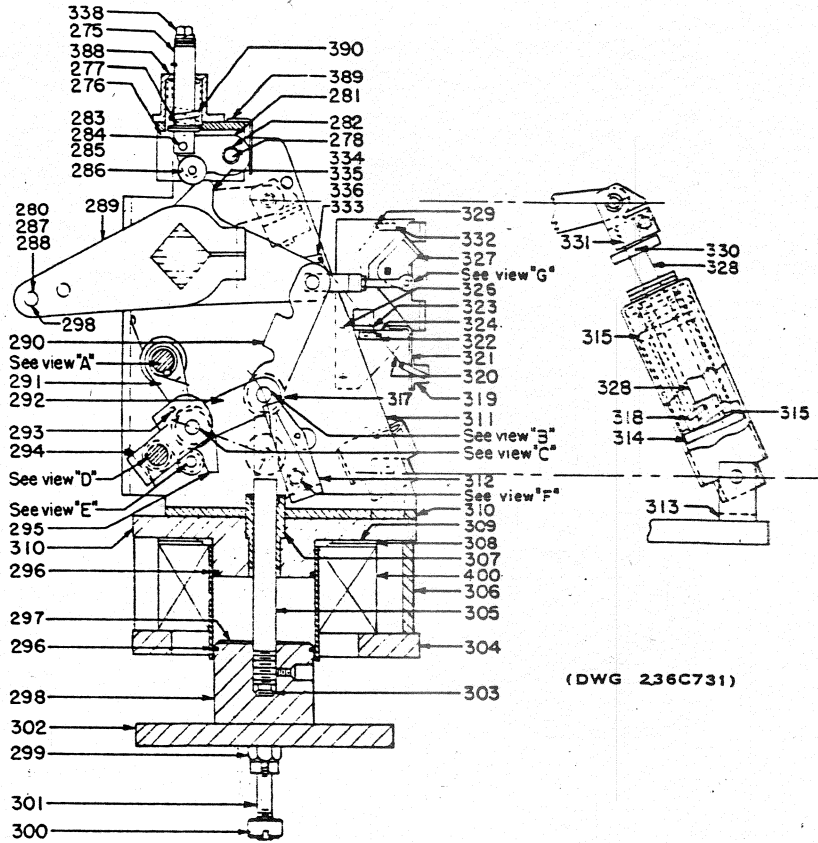

Fig. 8. Cross-section of mechanism for type AM-13.8-1 and -2 breakers

PARTS REFERENCED IN FIG. 7 and 8 (CONT'D)

Fig. No.	Ref. No.	MVA	AMP	Catalog Number for			No. Req.	Description
				AM-13.8(MVA)-0	AM-13.8(MVA)-1	AM-13.8(MVA)-2		
7, 8	359	ALL	ALL	6477424P9	6477424P9	6477424P9	5	Retaining ring
7, 8	360	ALL	ALL	6509799	6509799	6509799	2	Spring
7, 8	361	ALL	ALL	6477425BAP2	258C609P6	258C609P6	1	Roller
7, 8	362	ALL	ALL	6477400P5	6477400P5	6477400P5	10	Washer
7, 8	363	ALL	ALL	6477401CAP2	6477401CAP2	6477401CAP2	2	Spacer
7, 8	364	ALL	ALL	6477424P5	6477424P5	6477424P5	9	Retaining ring
7, 8	365	ALL	ALL	6477427BAP11	6477427BAP11	6477427BAP11	1	Pin
7, 8	368	ALL	ALL	258C609P8	258C609P8	258C609P8	1	Pin
7, 8	370	ALL	ALL	6370567P55	6370567P55	6370567P55	2	Bushing
7, 8	372	ALL	ALL	6443680	6443680	6443680	1	Pin
7, 8	373	ALL	ALL	6443707	174V392	174V392	1	Coupling
7, 8	374	ALL	ALL	6442374	6442374	6442374	1	Eye bolt
7, 8	375	ALL	ALL	6244347P1	6244347P1	6244347P1	1	Bearing
7, 8	376	ALL	ALL	6442366	6442366	6442366	1	Spacer
7	377	ALL	ALL	6477401BAP3	6477401BAP3	6477401BAP3	1	Spacer
7, 8	378	ALL	ALL	6442367	6442367	6442367	1	Pin
7, 8	379	ALL	ALL	6557286	6557286	6557286	1	Support and pin for auxiliary switch
7, 8	385	ALL	ALL	421A256P1	421A256P1	421A256P1	1	Checking spring for latch
8	387	ALL	ALL	175V268	175V268	175V268	1	Spacer
8	388	ALL	ALL	*	273B207G1	273B207G1	1	Guide and bracket assembly for plunger
8	389	ALL	ALL	*	6597206P1	6597206P1	1	Cover
8	390	ALL	ALL	6509728	6509728	6509728	1	Spring for interlock
7, 8	400	ALL	ALL	6375521G2	6375521G2	6375521G2	1	Closing coil, 125-volt, d-c
7, 8	400	ALL	ALL	6375521G1	6375521G1	6375521G1	1	Closing coil, 250-volt, d-c

* Not furnished in this breaker.

TYPE AM-13.8 AIR CIRCUIT BREAKERS

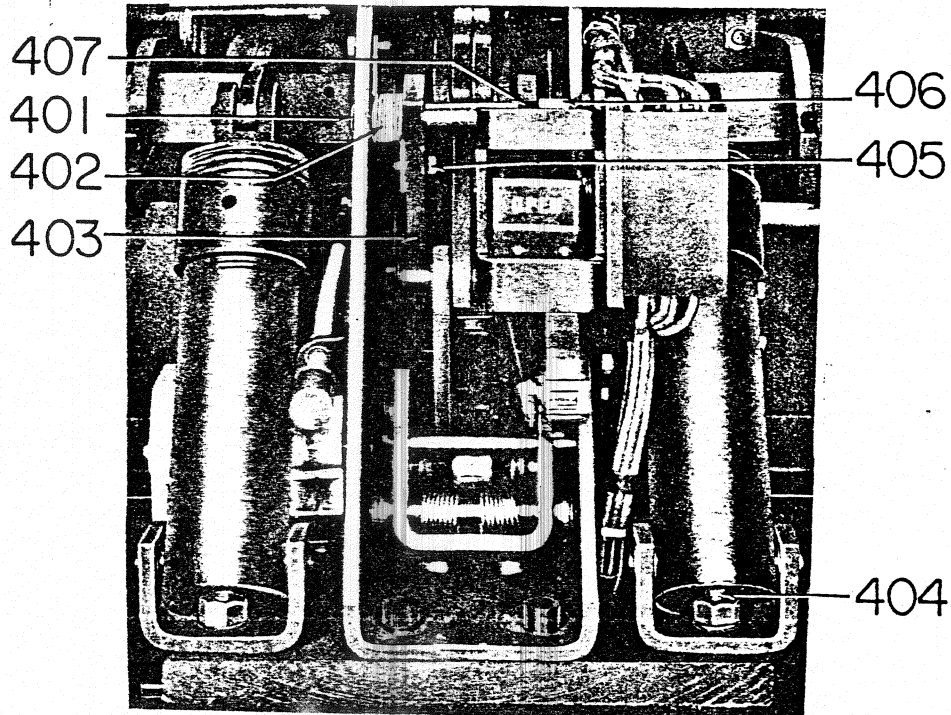

(Photo 8012468)

Fig. 9. Front view of mechanism

PARTS REFERENCED IN FIG. 9

Fig. No.	Ref. No.	MVA	AMP	Catalog Number for			No. Req.	Description
				AM-13.8(MVA)-0	AM-13.8(MVA)-1	AM-13.8(MVA)-2		
9	401	ALL	ALL	6597224P2	374A220P1	374A220P1	1	Shaft for prop
9	402	ALL	ALL	6551734	6551734	6551734	1	Spring
9	403	ALL	ALL	6443674	374A217P1	374A217P1	2	Prop
9	404	ALL	ALL	6477414ACP24	6477414ACP24	6477414ACP24	2	Stud
9	405	ALL	ALL	383A946P1	383A946P1	383A946P1	1	Screw
9	406	ALL	ALL	6477401DAP11	6477401DAP11	6477401DAP11	2	Spacer
9	407	ALL	ALL	*	374A217P2	374A217P2	1	Prop

* Not furnished with this breaker.

TYPE AM-13.8 AIR CIRCUIT BREAKERS

GEF-3875C

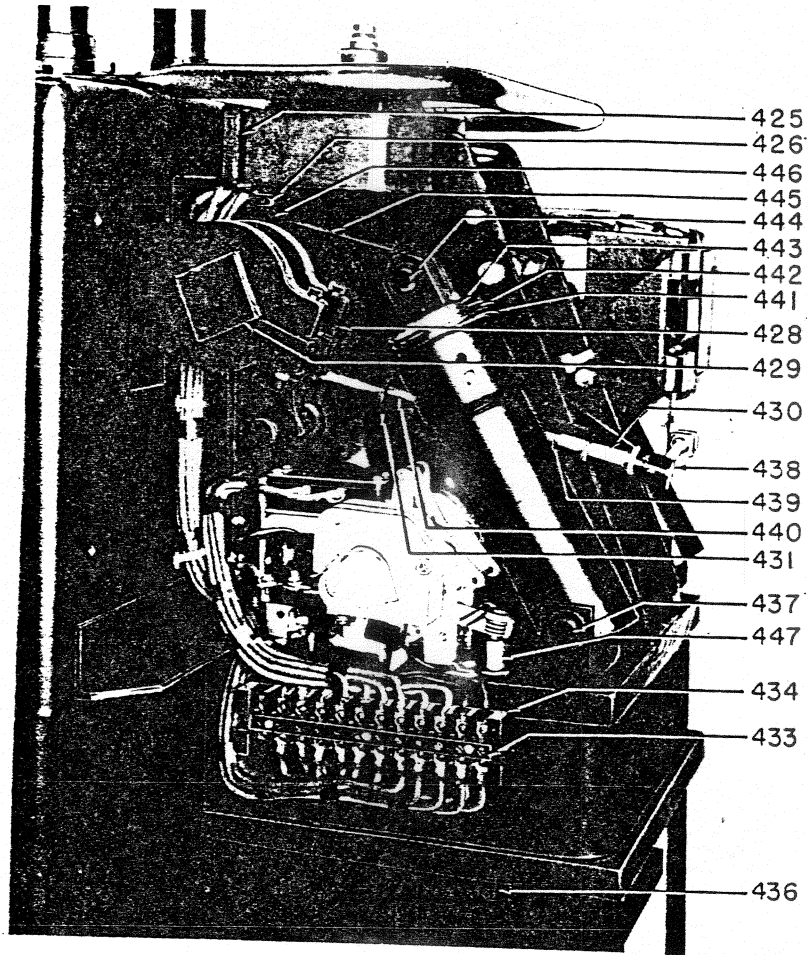

Fig. 10. Left-side view of mechanism

(PHOTO 8012469)

PARTS REFERENCED IN FIG. 10

Fig. No.	Ref. No.	MVA	AMP	Catalog Number for			No. Req.	Description
				AM-13.8(MVA)-0	AM-13.8(MVA)-1	AM-13.8(MVA)-2		
10	425	ALL	ALL	6557827P1	6557827P1	*	4	Shim
10	426	ALL	ALL	6597452P1	6597452P1	6597245P1	1	Cleat
10	428	ALL	ALL	6442241P2	6442241P2	6442241P2	2	Spacer
10	429	ALL	ALL	6443518P1	6443518P1	6443518P1	1	Shaft
10	430	ALL	ALL	6477401AAP36	6477401AAP36	6477401AAP36	2	Spacer
10	431	ALL	ALL	6591705P1	6591705P1	6591705P1	1	Bracket
10	433	ALL	ALL	6272491P4	6507829P1	6507829P1	1	Marking strip
10	434	ALL	ALL	6556276G84	6556276G84	6556276G84	1	Terminal board
10	436	ALL	ALL	6442362P3	174V393P1	174V393P1	1	Rod
10	437	ALL	ALL	6477427CAP8	6477427CAP20	6477427CAP20	2	Pin
10	438	ALL	ALL	6442274	6442274	6442274	1	Knob
10	439	ALL	ALL	6477414ADP4	6477414ADP4	6477414ADP4	1	Stud
10	440	ALL	ALL	6509752	6509752	6509752	1	Spring for hand trip
10	441	ALL	ALL	6477417AAP7	6477417AAP7	6477417AAP7	2	Washer
10	442	ALL	ALL	414A109P2	414A109P2	414A109P2	6	Buffer
10	443	ALL	ALL	6477879P8	6477879P8	6477879P8	2	Washer
10	444	ALL	ALL	6477427LAP1	6477427LAP1	6477427LAP1	2	Pin
10	445	ALL	ALL	6591700P1	6591700P1	6591700P1	2	Crank
10	446	ALL	ALL	6597451P1	6597451P1	6597451P1	1	Guard
10	447	ALL	ALL	174V394P1	174V394P1	174V394P1	1	Tube

* Not furnished with this breaker.

TYPE AM-13.8 AIR CIRCUIT BREAKERS

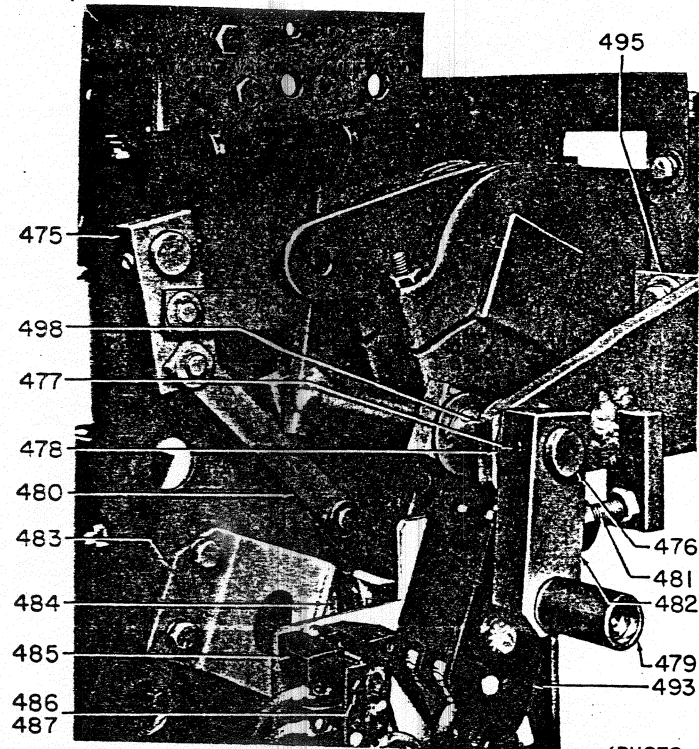

(PHOTO 8019962)

Fig. 11. Mechanical and electrical positive interlock

PARTS REFERENCED IN FIG. 11

Fig. No.	Ref. No.	MVA	AMP	Catalog Number for			No. Req.	Description
				AM-13. 8(MVA)-0	AM-13. 8(MVA)-1	AM-13. 8(MVA)-2		
11	475	ALL	ALL	6443678	374A215P1	264B193G2	1	Crank
11	476	ALL	ALL	6557063P1	374A221P2	374A221P2	1	Shaft for interlock
11	377	ALL	ALL	6477415P7	6477415P7	6477415P7	1	Groov-pin
11	478	ALL	ALL	6477400P7	6477400P7	6477400P7	3	Washer
11	479	ALL	ALL	6557285	384A331G1	384A331G1	1	Crank assembly for interlock
11	480	ALL	ALL	374A218P1	374A218P1	374A218P1	2	Link
11	481	ALL	ALL	6445006P1	6445006P1	6445006P1	1	Screw
11	482	ALL	ALL	6445137	374A216P1	374A216P1	1	Crank
11	483	ALL	ALL	6442232	6442232	6442232	2	Support for trip coil
11	484	ALL	ALL	414A109P3	313A109P3	414A109P3	2	Washer
11	485	ALL	ALL	6556276G84	6556276G84	6556276G84	1	Terminal board
11	486	ALL	ALL	6507829P1	6507829P1	6507829P1	1	Marking strip
11	487	ALL	ALL	6273142P2	6273142P2	6273142P2	1	Marking tag
11	493	ALL	ALL	6353582G1	6353582G1	6353582G1	1	Checking switch for latch
11	495	ALL	ALL	6557889P5	6557889P5	6557889P5	1	Shim
11	498	ALL	ALL	374A224G1	374A224G1	374A224G1	1	Bracket and stop assembly
11	499	ALL	ALL	6174582G1	6174582G1	6174582G1	1	Potential trip coil, 125-volt, d-c
11	499	ALL	ALL	6174582G2	6174582G2	6174582G2	1	Potential trip coil, 250-volt, d-c
11	499	ALL	ALL	6174582G14	6174582G14	6174582G14	1	Potential trip coil, 230-volt, a-c
11	499	ALL	ALL	6275070G1	6275070G1	6275070G1	1	Potential trip coil, 24-volt, d-c
11	499	ALL	ALL	6275070G2	6275070G2	6275070G2	1	Potential trip coil, 48-volt, d-c

TYPE AM-13.8 AIR CIRCUIT BREAKERS

GEF-3875C

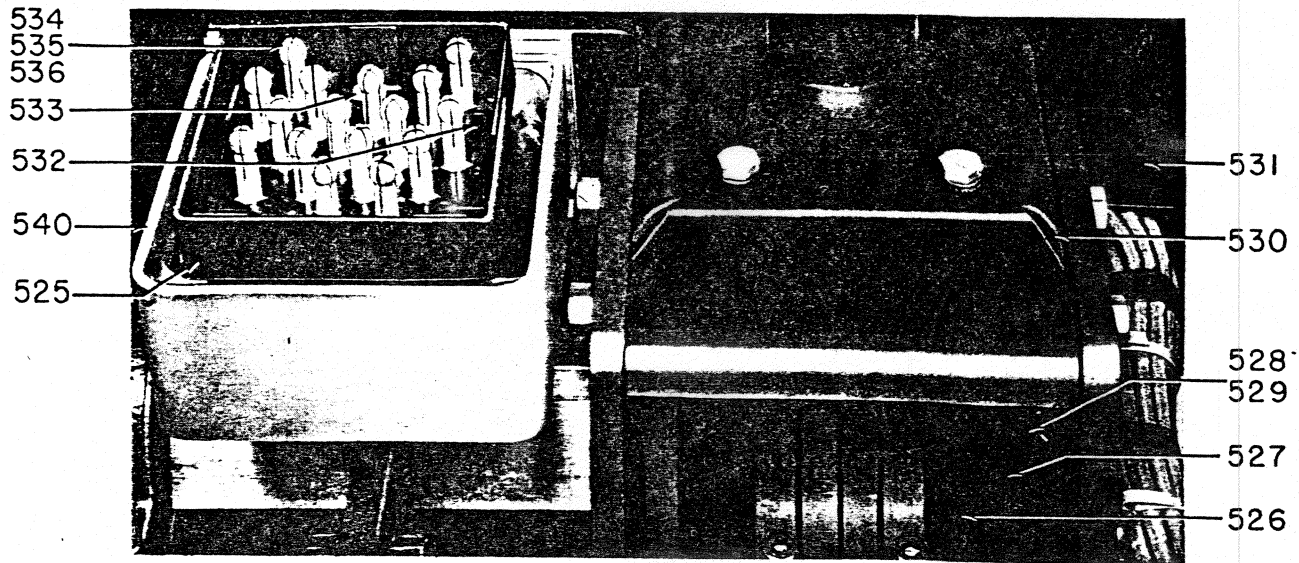

Fig. 12. Secondary disconnecting device; and mechanism parts

(PHOTO 8012576)

PARTS REFERENCED IN FIG. 12

Fig. No.	Ref. No.	MVA	AMP	Catalog Number for			No. Req.	Description
				AM-13.8(MVA)-0	AM-13.8(MVA)-1	AM-13.8(MVA)-2		
12	500	{150, 250, 500, 500B}	ALL	264B162G1	264B162G1	264B162G1	1	Secondary disconnecting device, complete, 16 point
12	500	{150A, 250A, 500A, 500AB}	ALL	264B173G1	264B173G1	264B173G1	2	Secondary disconnecting device, complete, 7 point
12	525	ALL	ALL	6597268AA	6597268AA	6597268AA	1	Shield
12	526	ALL	ALL	6442243	6442243	6442243	2	Spacer
12	527	ALL	ALL	6442244	6442244	6442244	4	Shim
12	528	ALL	ALL	6442239P2	6442239P2	6442239P2	2	Bearing
12	529	ALL	ALL	6442238	6442238	6442238	2	Bushing
12	530	ALL	ALL	6597206P1	6597206P1	6597206P1	1	Cover
12	531	ALL	ALL	6597450P1	366A673P1	366A673P1	1	Wiring trough
12	532	{150, 250, 500, 500B}	ALL	6505244P1	6505244P1	6505244P1	1	Socket
12	532	{150A, 250A, 500A, 500AB}	ALL	6048758	6048758	6048758	2	Socket
12	533	ALL	ALL	6443717	6443717	6443717	3	Stud
12	534	ALL	ALL	848768P1	848768P1	848768P1	16	Lock washer
12	535	ALL	ALL	366A234P3	366A234P2	366A234P2	16	Contact nut
12	536	ALL	ALL	6319964P2	6319964P2	6319964P2	16	Contact plug
12	540	{150, 250, 500, 500B}	ALL	6597453P1	6597453P1	6597453P1	1	Housing
12	540	{150A, 250A, 500A, 500AB}	ALL	258C459G1	258C459G1	258C459G1	2	Housing

TYPE AM-13.8 AIR CIRCUIT BREAKERS

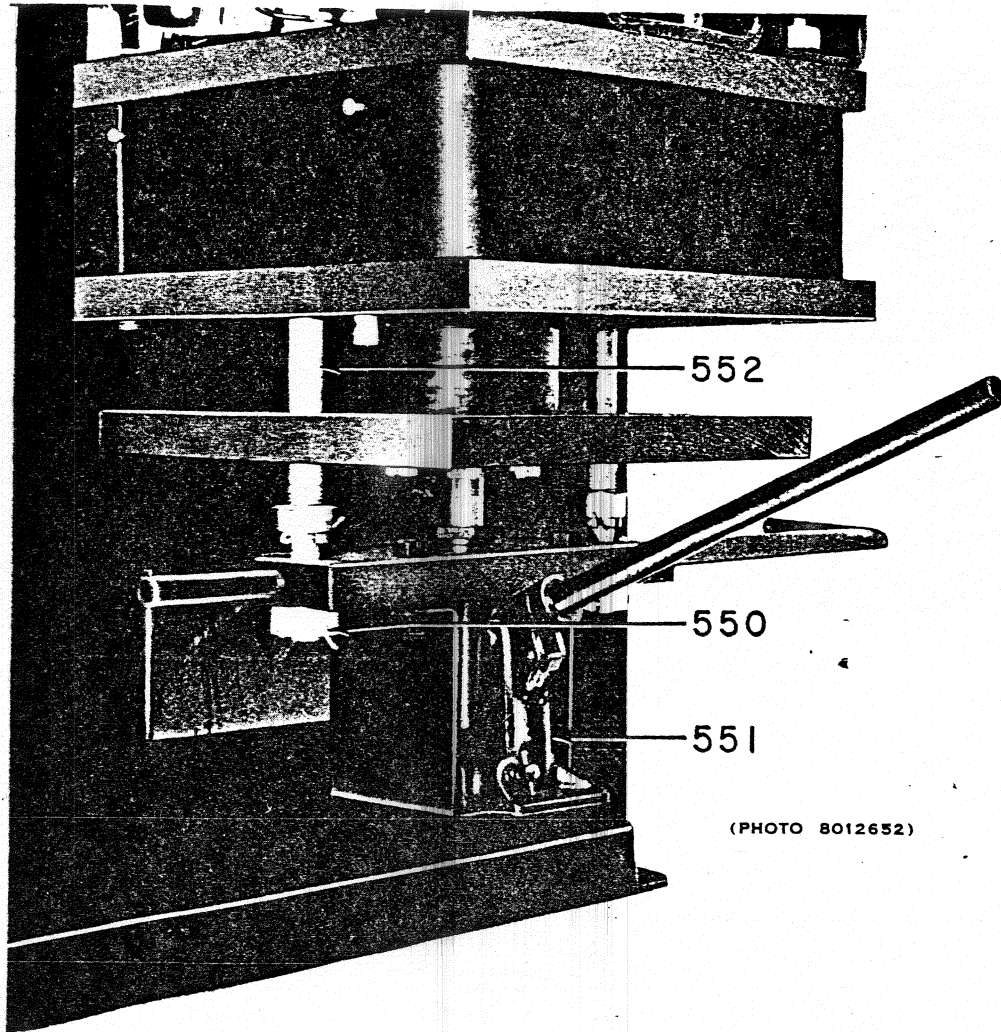

Fig. 13. Maintenance closing device

PARTS REFERENCED IN FIG. 13

Fig. No.	Ref. No.	MVA	AMP	Catalog Number for			No. Req.	Description
				AM-13.8(MVA)-0	AM-13.8(MVA)-1	AM-13.8(MVA)-2		
13	550	ALL	ALL	6443758	6443758	6443758	2	Nut
13	551	ALL	ALL	258C669G1	258C669G1	258C669G1	1	Maintenance closing device
13	552	ALL	ALL	6443757	6443757	6443757	2	Stud

TYPE AM-13.8 AIR CIRCUIT BREAKERS

GEF-3875C

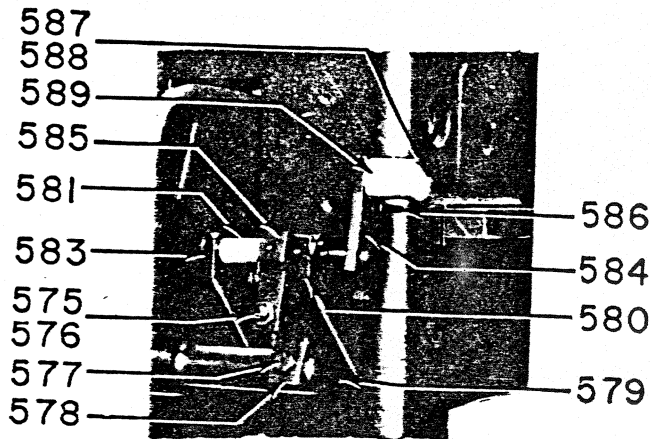

(PHOTO 8011671)

Fig. 14. Crank assembly for mechanism

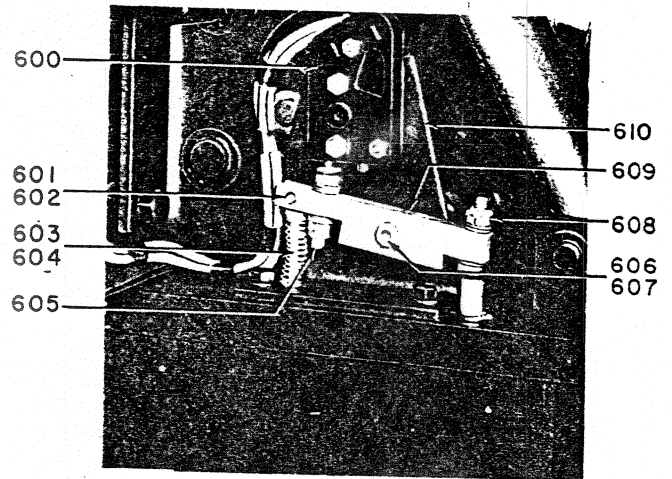

(PHOTO 8011670)

Fig. 15. Manual trip and cut-off switch for mechanism

PARTS REFERENCED IN FIG. 14 AND 15

Fig. No.	Ref. No.	MVA	AMP	Catalog Number for			No. Req.	Description
				AM-13.8(MVA)-0	AM-13.8(MVA)-1	AM-13.8(MVA)-2		
14	575	ALL	ALL	6445067	6445067	6445067	1	Trip bolt
14	576	ALL	ALL	6077731P2	6477429P2	6477429P2	1	Elastic stop nut
14	577	ALL	ALL	6477412AAP25	6477412AAP25	6477412AAP25	1	Screw
14	578	ALL	ALL	6443716	6443716	6443716	1	Angle
14	579	ALL	ALL	6557889P3	6557889P3	6557889P3	2	Shim
14	580	ALL	ALL	6592507P1	6592507P1	6592507P1	1	Bracket
14	581	ALL	ALL	6509729	6509729	6509729	1	Spring
14	583	ALL	ALL	6477400P18	6477400P18	6477400P18	2	Washer
14	584	ALL	ALL	6597274AA	6597274AA	6597274AA	1	Shaft assembly
14	585	ALL	ALL	6597273AA	6597273AA	6597273AA	1	Spring arm
14	586	ALL	ALL	6597211P1	6597211P1	6597211P1	1	Stop
14	587	ALL	ALL	6442360P3	6442360P3	6442360P3	1	Roller pin
14	588	ALL	ALL	6477400P3	6477400P3	6477400P3	1	Washer
14	589	ALL	ALL	6442362P3	6442362P3	6442362P3	1	Roller
15	600	ALL	ALL	6353582G3	6353582G3	6353582G3	1	Switch
15	601	ALL	ALL	6443657	6443657	6443657	1	Pin
15	602	ALL	ALL	6477424P2	6477424P2	6477424P2	2	Retaining ring
15	603	ALL	ALL	6509794	6509794	6509794	1	Spring
15	604	ALL	ALL	6443658	6443658	6443658	1	Guide for spring
15	605	ALL	ALL	6477412AAP22	6477412ABP22	6477412ABP22	1	Screw
15	606	ALL	ALL	6477412ABP3	6477412ABP3	6477412ABP3	1	Screw
15	607	ALL	ALL	6443656	6443656	6443656	1	Bushing
15	608	ALL	ALL	6477412AAP24	6477412AAP24	6477412AAP24	1	Screw
15	609	ALL	ALL	6557279P1	6557279P1	6557279P1	1	Operating lever
15	610	ALL	ALL	6597214P1	6597214P1	6597214P1	1	Support

TYPE AM-13.8 AIR CIRCUIT BREAKERS

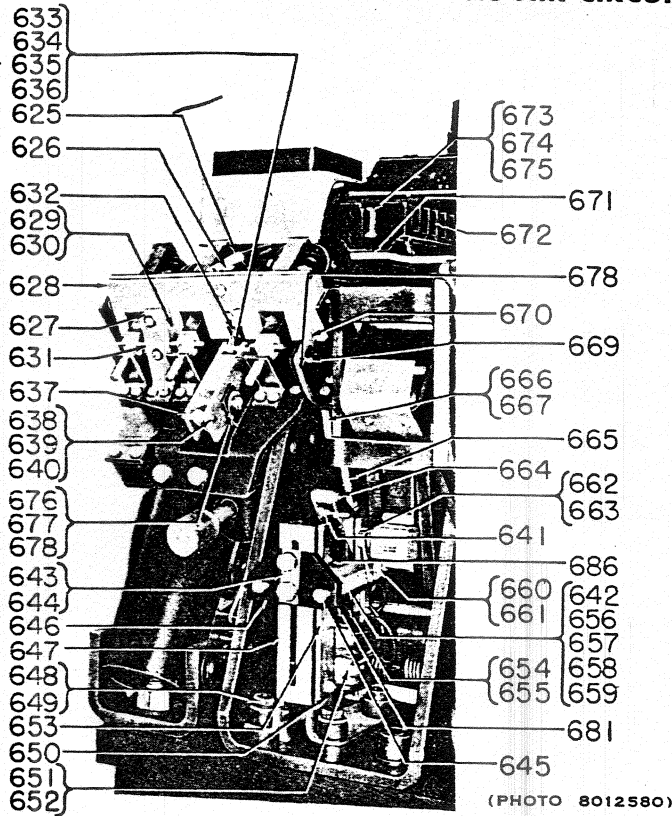

Fig. 16. Front view of mechanism with current trip and under voltage device

(PHOTO 8012580)

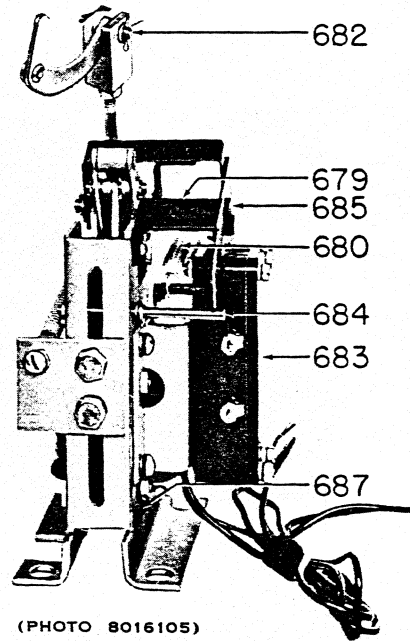

Fig. 17. Undervoltage device

PARTS REFERENCED IN FIG. 16

Fig. No.	Ref. No.	MVA	AMP	Catalog Number for			No. Req.	Description
				AM-13.8(MVA)-0	AM-13.8(MVA)-1	AM-13.8(MVA)-2		
16	625	ALL	ALL	6551725	6551725	6551725	1	Spring
16	626	ALL	ALL	6558782P1	6558782P1	6558782P1	1	Block
16	627	ALL	ALL	6558764P1	6558764P1	6558764P1	1	Shim
16	628	ALL	ALL	6597219G1	6597219G1	6597219G1	1	Trip pan
16	629	ALL	ALL	6558749P1	6558749P1	6558749P1	1	Retainer
16	630	ALL	ALL	6558766P1	6558766P1	6558766P1	1	Stop
16	631	ALL	ALL	6558748P1	6558748P1	6558748P1	1	Bracket
16	632	ALL	ALL	6558756P1	6558756P1	6558756P1	1	Trip latch
16	633	ALL	ALL	6477418AAP10	6477418AAP10	6477418AAP10	1	Ball bearing
16	634	ALL	ALL	6597449P2	6597449P2	6597449P2	1	Pin
16	635	ALL	ALL	6443759	6443759	6443759	2	Spacer
16	636	ALL	ALL	6477424P12	6477424P12	6477424P12	2	Retaining ring
16	637	ALL	ALL	366A600P1	366A600P1	366A600P1	1	Trip arm
16	638	ALL	ALL	6477402AAP307	6076401P307	6076401P307	1	Pin
16	639	ALL	ALL	6477424P1	6477424P1	6477424P1	6	Retaining ring
16	640	ALL	ALL	6477400P1	*	*	4	Washer
16	641	ALL	ALL	*	6477400P1	6477400P1	12	Washer
16	642	ALL	ALL	6477401AAP3	6477401AAP3	6477401AAP3	2	Spacer
16	643	ALL	ALL	6509798	6509798	6509798	2	Spring
16	644	ALL	ALL	6443763	6443763	6443763	1	Nut plate
16	645	ALL	ALL	6591388P21	6591388P21	6591388P21	1	Locking plate
16	646	ALL	ALL	6558730P1	6558730P1	6558730P1	2	Screw
16	646	ALL	ALL	6558713P1	6558713P1	6558713P1	1	Adjusting plate for spring (a-c)
16	646	ALL	ALL	6558713P1	175V271	175V271	1	Adjusting plate for spring (d-c)
16	647	ALL	ALL	6514924P1	6514924P1	6514924P1	1	Frame side plate
16	648	ALL	ALL	6443761	6443761	6443761	4	Mounting bolt
16	649	ALL	ALL	456A316P2	456A316P2	456A316P2	8	Mounting rubber
16	650	ALL	ALL	6591413G1	6591413G1	6591413G1	1	Magnet frame assembly
16	651	ALL	ALL	2236258	2236258	2236258	2	Spring
16	652	ALL	ALL	6275017G33	6275017G33	6275017G33	1	Coil for a-c only
16	652	ALL	ALL	6275017G19	6275017G19	6275017G19	1	Coil for d-c only (125-volt)
16	652	ALL	ALL	6275017G20	6275017G20	6275017G20	1	Coil for d-c only (250-volt)
16	653	ALL	ALL	6558783P1	6558783P1	6558783P1	1	Frame side plate

* Not furnished with this breaker.

TYPE AM-13.8 AIR CIRCUIT BREAKERS

GEF-3875C

PARTS REFERENCED IN FIG. 16 and 17

Fig. No.	Ref. No.	MVA	AMP	Catalog Number for			No. Req.	Description
				AM-13.8(MVA)-0	AM-13.8(MVA)-1	AM-13.8(MVA)-2		
16	654	ALL	ALL	6558741G1	6558741G1	6558741G1	1	Core assembly
16	655	ALL	ALL	2433013P1	2433013P1	2433013P1	2	Guide
16	656	ALL	ALL	6076401P311	6076401P311	6076401P311	3	Pin for a-c only
16	656	ALL	ALL	6076401P311	175V578	175V578	1	Pin for d-c only
16	657	ALL	ALL	6558721P1	6558721P1	6558721P1	1	Buffer
16	658	ALL	ALL	6477401BAP5	6477401BAP5	6477401BAP5	1	Spacer
16	659	ALL	ALL	6477424P1	6477424P1	6477424P1	14	Retaining ring
16	660	ALL	ALL	6558722P2	6558722P2	6558722P2	1	Pin for a-c only
16	660	ALL	ALL	175V275	175V275	175V275	1	Pin for d-c only
16	661	ALL	ALL	6477424P2	6477424P2	6477424P2	4	Retaining ring
16	662	ALL	ALL	6076402P311	6076402P311	6076402P311	1	Pin for a-c only
16	662	ALL	ALL	175V577	175V577	175V577	1	Pin for d-c only
16	663	ALL	ALL	6477400P2	6477400P2	6477400P2	2	Washer
16	664	ALL	ALL	366A612G1	366A612G1	366A612G1	1	Link and pin
16	665	ALL	ALL	6477414ACP20	6477414ACP20	6477414ACP20	1	Stud
16	666	ALL	ALL	6076401P305	6076401P305	6076401P305	2	Pin
16	667	ALL	ALL	6558711P1	6558711P1	6558711P1	2	Coupling
16	668	ALL	ALL	6558720P1	6558720P1	6558720P1	2	Bracket
16	669	ALL	ALL	6076401P301	6076401P301	6076401P301	1	Pin
16	670	ALL	ALL	6558723G1	6558723G1	6558723G1	1	Trip arm
16	671	ALL	ALL	174V365	174V365	174V365	1	Bracket
16	672	ALL	ALL	6556276G85	6556276G85	6556276G85	1	Terminal board
16	673	ALL	ALL	6273142P2	6273142P2	6273142P2	1	Marking tag
16	674	ALL	ALL	6507829P2	6507829P2	6507829P2	1	Marking strip
16	675	ALL	ALL	6047841	6047841	6047841	4	Screw
16	676	ALL	ALL	6477424AAP8	6076404P313	6076404P313	1	Pin
16	677	ALL	ALL	6477424P4	6477424P4	6477424P4	2	Retaining ring
16	678	ALL	ALL	6477400P4	6477400P4	6477400P4	4	Washer
17	679	ALL	ALL	175V574	175V574	175V574	1	Stop for d-c only
17	680	ALL	ALL	456A311	456A311	456A311	1	Spring for d-c only
16	681	ALL	ALL	6551726	6551726	6551726	1	Spring for a-c only
17	682	ALL	ALL	6076401P305	6076401P305	6076401P305	2	Pin
17	683	ALL	ALL	295B227G2	295B227G2	295B227G2	1	Switch for d-c only
17	684	ALL	ALL	175V576	175V576	175V576	1	Pin
17	685	ALL	ALL	384A330G1	384A330G1	384A330G1	1	Link arm assembly for d-c only
16	686	ALL	ALL	6076401P311	6076401P311	6076401P311	3	Pin
17	687	ALL	ALL	175V562	175V562	175V562	1	Shim for d-c only

TYPE AM-13.8 AIR CIRCUIT BREAKERS

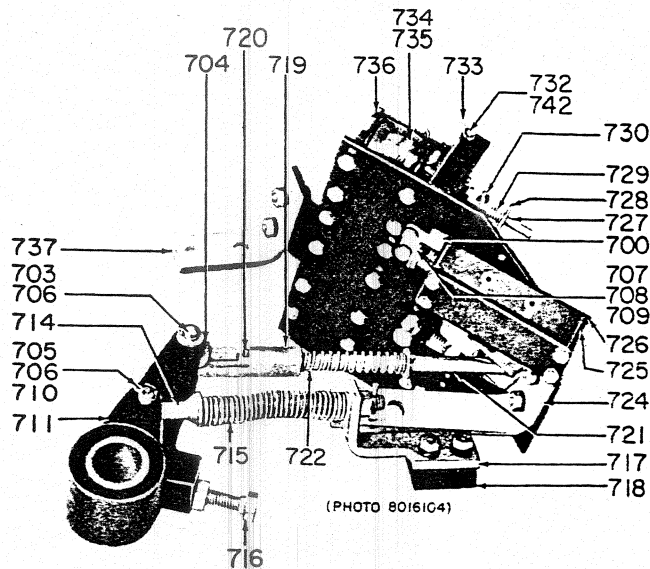

Fig. 18. Impact trip device

PARTS REFERENCED IN FIG. 18

Fig. No.	Ref. No.	MVA	AMP	Catalog Number for			No. Req.	Description
				AM-13.8(MVA)-0	AM-13.8(MVA)-1	AM-13.8(MVA)-2		
18	700	ALL	ALL	6558746P1	6558746P1	6558746P1	1	Bracket
18	703	ALL	ALL	6076403P315	6076403P315	6076403P315	1	Pin
18	704	ALL	ALL	6477425BAP3	6477425BAP3	6477425BAP3	1	Roller
18	705	ALL	ALL	6477424P3	6477424P3	6477424P3	4	Retaining ring
18	706	ALL	ALL	6477400P3	6477400P3	6477400P3	4	Washer
18	707	ALL	ALL	6558747P1	6558747P1	6558747P1	1	Trip arm
18	708	ALL	ALL	6076401P315	6076401P315	6076401P315	1	Pin
18	709	ALL	ALL	6477401AAP3	6477401AAP3	6477401AAP3	2	Spacer
18	710	ALL	ALL	6076403P311	6076403P311	6076403P311	1	Pin
18	711	ALL	ALL	6592554G1	6592554G1	6592554G1	1	Crank and bushing
18	714	ALL	ALL	6558791G1	6558791G1	6558791G1	1	Eye bolt assembly
18	715	ALL	ALL	6509706	6509706	6509706	1	Spring
18	716	ALL	ALL	6557106P1	6557106P1	6557106P1	1	Screw
18	717	ALL	ALL	6443516	6443516	6443516	1	Bracket
18	718	ALL	ALL	6557105P1	6557105P1	6557105P1	1	Spacer
18	719	ALL	ALL	174V373	174V373	174V373	1	Coupling
18	720	ALL	ALL	6477415P17	6477415P17	6477415P17	2	Groov-pin
18	721	ALL	ALL	174V378	174V378	174V378	1	Rod
18	722	ALL	ALL	6509794	6509794	6509794	1	Spring
18	724	ALL	ALL	6443666	6443666	6443666	1	Bracket
18	725	ALL	ALL	6418068G7	6418068G7	6418068G7	1	Switch
18	726	ALL	ALL	6592505AA	6592505AA	6592505AA	1	Frame assembly
18	727	ALL	ALL	6558752G1	6558752G1	6558752G1	3	Core assembly
18	728	ALL	ALL	6558751P1	6558751P1	6558751P1	3	Angle
18	729	ALL	ALL	6477094	6477094	6477094	3	Spring
18	730	ALL	ALL	6557068P9	6557068P9	6557068P9	3	Pin
18	732	ALL	ALL	6076401P385	6076401P385	6076401P385	1	Pin
18	733	ALL	ALL	2236575	2236575	2236575	6	Guide
18	734	ALL	ALL	6174599G2	6174599G2	6174599G2	3	Current trip/coil
18	735	ALL	ALL	6174599G6	6174599G6	6174599G6	1	Capacitor trip coil
18	736	ALL	ALL	4905058G4	4905058G4	4905058G4	3	Frame and armature
18	737	ALL	ALL	6443667	6443667	6443667	1	Bracket
18	742	ALL	ALL	6076401P301	6076401P385	6076401P385	1	Pin

TYPE AM-13.8 AIR CIRCUIT BREAKERS

GEF-3875C

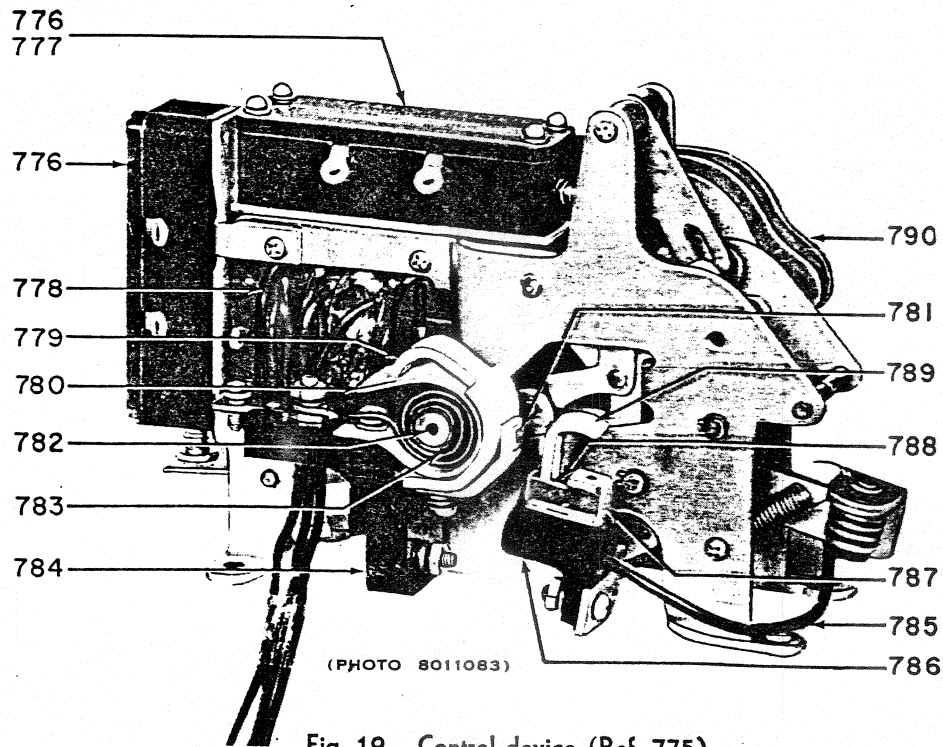

PARTS REFERENCED IN FIG. 19

Fig. No.	Ref. No.	MVA	AMP	Catalog Number for			No. Req.	Description
				AM-13.8(MVA)-0	AM-13.8(MVA)-1	AM-13.8(MVA)-2		
19	775	ALL	ALL	6375988G5	6375988G5	6375988G5	1	Control device, 125-volt, d-c
19	775	ALL	ALL	6375988G8	6375988G8	6375988G8	1	Control device, 220-volt, d-c
19	775	ALL	ALL	6375988G6	6375988G6	6375988G6	1	Control device, 250-volt, d-c
19	775	ALL	ALL	6375988G9	6375988G9	6375988G9	1	Control device, 230-volt, a-c
19	776	ALL	ALL	295B227G2	295B227G2	295B227G2	2	Auxiliary switch, top or back
19	777	ALL	ALL	295B227G1	295B227G1	295B227G1	1	Auxiliary switch, top, 230-volt, a-c
19	778	ALL	ALL	6275017G19	6275017G19	6275017G19	1	Coil, 125-volt, d-c
19	778	ALL	ALL	6275017G31	6275017G31	6275017G31	1	Coil, 220-volt, d-c
19	778	ALL	ALL	6275017G20	6275017G20	6275017G20	1	Coil, 250-volt, d-c
19	778	ALL	ALL	6275017G34	6275017G34	6275017G34	1	Coil, 230-volt, a-c
19	779	ALL	ALL	6591455P1	6591455P1	6591455P1	2	Support for contact tip
19	780	ALL	ALL	6442392P1	6442392P1	6442392P1	2	Insulation
19	781	ALL	ALL	6591411G1	6591411G1	6591411G1	2	Support for stationary contact
19	782	ALL	ALL	6591450P1	6591450P1	6591450P1	2	Core
19	783	ALL	ALL	6412255P1	6412255P1	6412255P1	2	Blowout coil
19	784	ALL	ALL	6412251P1	6412251P1	6412251P1	2	Support for coil
19	785	ALL	ALL	6591440G1	6591440G1	6591440G1	1	Connector
19	786	ALL	ALL	6592161P1	6592161P1	6592161P1	2	Support for contact carrier
19	787	ALL	ALL	6592162P1	6592162P1	6592162P1	2	Shield
19	788	ALL	ALL	6477041P1	6477041P1	6477041P1	2	Spring
19	789	ALL	ALL	6591412G1	6591412G1	6591412G1	2	Movable contact
19	790	ALL	ALL	6591404G1	6591404G1	6591404G1	2	Arc chute assembly

GENERAL ELECTRIC SALES OFFICES

SALES OFFICE CODE KEY
 * Industrial Equipment (including Agent and Distributor) Sales
 † Electric Utility Equipment Sales
 ‡ Marine and Defense Equipment Sales
 § Component Sales Operation

ALABAMA
 * † Birmingham 35205 2151 Highland Ave.
 * † Mobile 36602 704 Government St.

ARIZONA
 * † Phoenix 85012 3550 N. Central Ave.
 * † Tucson 85711 151 S. Tucson Blvd.

ARKANSAS
 * † North Little Rock 72114 1900 E. Washington
 † Pine Bluff 71602 P. O. Box 1033

CALIFORNIA
 † Fresno 93728 1532 N. West Ave.
 * † Los Angeles 90054 212 N. Vignes St.
 † Los Angeles 90005 3325 Wilshire Blvd.
 † Oakland 94612 409 Thirteenth St.
 † Redwood City 94063 55 Veterans Blvd.
 † Sacramento 95816 2407 "J" St.
 † San Diego 92103 2560 First Ave.
 † San Francisco 94106 235 Montgomery St.
 † San Jose 95128 2155 So. First St.

COLORADO
 * † Denver 80201 201 University Blvd.

CONNECTICUT
 * † Hamden 06518 2905-2921 Dixwell Ave.
 * † Hartford 06105 764 Asylum Ave.

DISTRICT OF COLUMBIA
 * † Washington 20005 777-14th St., N.W.

FLORIDA
 † Cocoa Beach (Cape Canaveral Office) 1325 N. Atlantic Ave.
 † Coral Gables 33146 250 Bird Road
 † Jacksonville 32202 1901 Hill St.
 † Miami 33134 4100 West Flagler St.
 † Pensacola 32503 First Bank Bldg.
 † Tampa 33609 Henderson Blvd. at Lois Ave.
 † Tampa 33609 2106 S. Lois Ave.

GEORGIA
 * † Atlanta 30309 1860 Peachtree Rd., N.W.
 * † Macon 31202 682 Cherry St.
 * † Savannah 31405 5002 Paulsen St.

IDAHO
 † Boise 83706 1524 Idaho St.

ILLINOIS
 * † Chicago 60680 840 S. Canal St.
 † Peoria 61603 2008 N.E. Perry Ave.
 † Rockford 61105 4223 East State St.
 † Springfield 62701 607 E. Adams St.

INDIANA
 * † Evansville 47714 2709 Washington Ave.
 † Fort Wayne 46807 1635 Broadway
 † Fort Wayne 46806 3606 S. Calhoun St.
 † Indianapolis 46207 3750 N. Meridian St.
 † South Bend 46601 430 N. Michigan St.

IOWA
 * † Cedar Rapids 52401 210 Second St., S.E.
 † Davenport 52805 1039 State St., Bettendorf, Iowa
 † Des Moines 50310 3839 Merle Hay Rd.
 † Sioux City 51101 520 Pierce St.

KANSAS
 * † Wichita 67211 820 E. Indianapolis Ave.

KENTUCKY
 † Lexington 40503 465 E. High St.
 † Louisville 40218 2300 Meadow Dr.

LOUISIANA
 * † Alexandria 71302 720 Murray St.
 † Baton Rouge 70815 633 Oak Villa Blvd.
 † Lake Charles 1424 Ryan St.
 † New Orleans 70112 837 Gravier St.
 † New Orleans 70125 4747 Earhart Blvd.
 † Shreveport 71101 400 Travis St.

MAINE
 † Augusta 152 State St.
 † Bangor 04402 77 Central St.

MARYLAND
 * † Baltimore 21201 1 North Charles
 † Hagerstown 49 East Franklin St.

MASSACHUSETTS
 * † Boston 02117 31 St. James Ave.
 † Springfield 01103 120 Maple St.
 † Worcester 01605 288 Grove St.

MICHIGAN
 † Detroit 48202 700 Antoinette St.
 † Flint 48503 316 1/2 W. Court St.
 † Grand Rapids 49508 2821 Madison Ave., S.E.
 † Jackson 49201 210 W. Franklin St.
 † Kalamazoo 927 S. Burdick St.
 † Lansing 48901 501 Bank of Lansing Bldg.
 † Saginaw 48607 Second National Bank Bldg.

MINNESOTA
 † Duluth 55802 14 W. Superior St.
 † Fergus Falls 56537 106 E. Washington St.
 † Minneapolis 55402 12 S. Sixth St.

MISSISSIPPI
 † Gulfport 39502 P.O. Box 23
 † Jackson 39201 210 S. Lamar St.

MISSOURI
 † Joplin 64802 212 1/2 W. Fifth St.
 † Kansas City 64105 106 W. Fourteenth St.
 † St. Louis 63101 1015 Locust St.

MONTANA
 † Billings 59101 303 N. Broadway
 † Butte 59701 103 N. Wyoming St.

NEBRASKA
 † Omaha 68102 402 S. Seventeenth St.

NEVADA
 † Las Vegas 89106 1711 S. 8th St.

NEW HAMPSHIRE
 † Manchester 03104 1662 Elm St.

NEW JERSEY
 * † East Orange 07017 26 Washington St.

NEW MEXICO
 * † Albuquerque 87108 120 Madeira Drive, N.E.

NEW YORK
 † Albany 12203 8 Calvin Ave.
 † Binghamton 13902 19 Chenango St.
 † Buffalo 14202 625 Delaware Ave.
 † New York 10022 570 Lexington Ave.
 † Rochester 14604 89 East Ave.
 † Syracuse 13206 3532 James St.
 † Utica 13501 1001 Broad St.
 † Waverly 14892 P.O. Box 308

NORTH CAROLINA
 * † Charlotte 28202 129 W. Trade St.
 † Greensboro 27405 801 Summit Ave.
 † Raleigh 27602 16 W. Martin St.

NORTH DAKOTA
 † Bismarck 58501 418 Rosser Ave.

OHIO
 † Akron 44313 2858 W. Market St.
 † Canton 44701 515 Third St., N.W.
 † Cincinnati 45206 2621 Victory Pkwy.
 † Cleveland 44104 4966 Woodland Ave.
 † Columbus 43215 395 E. Broad St.
 † Columbus 43212 937 Burrell Ave.
 † Dayton 45402 11 W. Monument Ave.
 † Dayton 45402 118 W. First St.
 † Mansfield 44906 564 Park Ave., West
 † Toledo 43606 3125 Douglas Rd.
 † Youngstown 44507 272 E. Indianola Ave.

OKLAHOMA
 † Oklahoma City 73106 2000 Classen Blvd.
 † Tulsa 74114 Columbia Bldg., 2651 E. 21st St.

OREGON
 † Eugene 97401 1170 Pearl St.
 † Medford 97501 107 E. Main St.
 † Portland 97210 2929 N.W. 29th Ave.

PENNSYLVANIA
 † Allentown 18102 732 North 16th St.
 † Erie 16501 1001 State St.
 † Johnstown 15902 841 Oak St.
 † Philadelphia 19102 3 Penn Center Plaza
 † Pittsburgh 15222 The Oliver Bldg., Mellon Sq.
 † Pittsburgh 15228 733 Washington Rd.
 † York 17403 56 N. Harrison St.

SOUTH CAROLINA
 † Columbia 29201 1310 Lady St.
 † Greenville 29602 108 W. Washington St.

TENNESSEE
 † Chattanooga 37402 832 Georgia Ave.
 † Kingsport 37662 322 Commerce St.
 † Knoxville 37916 1301 Hannah Ave., N.W.
 † Memphis 38104 1420 Union Ave.
 † Murfreesboro P.O. Box 1040
 † Nashville 37203 1717 W. End Bldg.
 † Oak Ridge 253 Main St., East

TEXAS
 † Abilene 79601 442 Cedar St.
 † Amarillo 79101 403 Amarillo Blvd.
 † Beaumont 77701 1385 Calder Ave.
 † Corpus Christi 78401 205 N. Chaparral
 † Dallas 75207 8101 Stemmons Freeway
 † El Paso 79901 215 N. Stanton St.
 † Fort Worth 76102 408 W. Seventh St.
 † Houston 77027 4219 Richmond Avz.
 † Lubbock 79408 500 E. 50th St.
 † Midland 122 North N St.
 † San Antonio 78204 419 S. Main Ave.

UTAH
 * † Salt Lake City 84110 200 S.

VERMONT
 † Rutland 38 1/2 Center St.

VIRGINIA
 † Newport News 23601 P.O. Box 1038, 311 Main St.
 † Richmond 23230 5001 W. Broad St.
 † Roanoke 24005 920 S. Jefferson St.

WASHINGTON
 † Pasco 99301 824 W. Lewis St.
 † Seattle 98104 710 Second Ave.
 † Spokane 99220 S. 162 Post St.
 † Spokane 99220 E. 1805 Trent St.

WEST VIRGINIA
 † Charleston 25328 306 MacCorkle Ave., S.E.
 † Fairmont 26555 310 Jacobs Bldg.
 † Wheeling 40 Fourteenth St.

WISCONSIN
 * † Appleton 54910 510 W. College Ave.
 † Madison 53703 340 W. Washington Ave.
 † Milwaukee 53233 940 W. St. Paul Ave.

CANADA: Canadian General Electric Company, Ltd., Toronto

HAWAII: American Factors, Ltd., P.O. Box 3230, Honolulu 96801

WHEN YOU NEED SERVICE . . . These G-E service shops will repair, recondition, and rebuild your electric apparatus. The facilities are available day and night, seven days a week, for work in the shops or on your premises. Latest factory methods and genuine G-E renewal parts are used to maintain peak

performance of your equipment. For full information about these services, contact your nearest service shop or sales office.

ALABAMA
 Birmingham 35211, P.O. Box 3687
 7-18th St., S.W.

ARIZONA
 (Phoenix) Glendale 85301
 4911 West Colter St.

CALIFORNIA
 Los Angeles 90001 6900 Stanford Ave.
 (Los Angeles) Ontario Ontario International Airport
 Oakland 94608 3400 Wood St.
 Sacramento 95814 99 North 17th St.
 San Francisco 94103 1098 Harrison St.

COLORADO
 Denver 80205 3353 Larimer St.

CONNECTICUT
 (Southington) Plantsville 06479
 370 Atwater St.

FLORIDA
 Jacksonville 32203 P.O. Box 2932, 2020 W. Beaver St.
 (Miami) Hialeah 33010 1062 E. 28th St.
 Tampa 33601 P.O. Box 1245

GEORGIA
 (Atlanta) Chamblee 30005 5035 Peachtree Industrial Blvd.

ILLINOIS
 Chicago 60632 4360 W. 47th St.

INDIANA
 Ft. Wayne 46803 1731 Edsall Ave.
 Indianapolis 46222 1740 W. Vermont St.

IOWA
 (Davenport) Bettendorf 52722 1025 State St.

KANSAS
 (Strother) Arkansas City G.E. Co., P.O. Box 797

KENTUCKY
 Louisville 40209 3900 Crittenden Drive

LOUISIANA
 New Orleans 70117 1115 De Armas St.

MARYLAND
 Baltimore 21230 920 E. Fort Ave.

MASSACHUSETTS
 (Boston) Medford 02155 3960 Mystic Valley Parkway

MICHIGAN
 Detroit 48202 5950 Third St.

MINNESOTA
 Minneapolis 55430 2025-49th Ave., N.

MISSOURI
 Kansas City 64120 3525 Gardner Ave.
 St. Louis 63110 1115 East Road

NEW YORK
 Albany 12205 1097 Central Ave.
 Buffalo 14211 318 Urban St.
 (New York) Linden, N. J. 1611 W. Elizabeth Ave.
 (New York) North Bergen, N. J. 07047 6001 Tonelle Ave.
 Schenectady (Instrumentation Service) 12305 1 River Road

NORTH CAROLINA
 Charlotte 28208 2328 Thrift Road

OHIO
 Cincinnati 45202 444 W. Third St.
 Cincinnati 45232 260 W. Mitchell Ave.
 Cleveland 44125 4477 East 49th St.

Columbus 43223 P.O. Box 6198, 2128 Eakin Rd.
 Toledo 43605 405 Dearborn Ave.
 Youngstown 44507 272 E. Indianola Ave.

OREGON
 Portland 97210 2727 N.W. 29th Ave.

PENNSYLVANIA
 Allentown 18103 668 E. Highland St.
 Johnstown 15902 841 Oak St.
 Philadelphia 19124 1040 E. Erie Ave.
 (Pittsburgh) Homestead 15120 4930 Buttermilk Hollow Rd., RD #1,
 West Mifflin, Pa. 15122
 York 17403 54 N. Harrison St.

TEXAS
 Corpus Christi 78401 115 Waco St.
 Dallas 75235 3202 Manor Way
 Houston 77020 5534 Harvey Wilson Drive
 Midland 79704 704 S. Johnston St.

UTAH
 Salt Lake City 84104 301 S. 7th West St.

VIRGINIA
 Richmond 23224 1403 Ingram Ave.
 Roanoke 24007 P.O. Box 1327, 115 Albermarle Ave., S.E.

WASHINGTON
 Seattle 98134 3422 First Ave., S.
 Seattle 98108 220 Dawson St.
 Spokane 99206 E. 4323 Mission St.

WEST VIRGINIA
 Charleston 25328 306 MacCorkle Ave.

WISCONSIN
 Appleton 54910 Midway Industrial Area
 P.O. Box 83 County Trunk P.
 Milwaukee 53233 940 W. St. Paul Ave.

SWITCHGEAR DEPARTMENT, GENERAL ELECTRIC COMPANY, PHILADELPHIA, PA.