



Power Circuit Breaker

TYPE

AKF-2A-25 & AKF-2-25

**ELECTRICALLY OPERATED
AND MANUAL OPERATED**

These instructions do not purport to cover all details or variations in equipment nor to provide for every possible contingency to be met in connection with installation, operation or maintenance. Should further information be desired or should particular problems arise which are not covered sufficiently for the purchaser's purposes, the matter should be referred to the General Electric Company.

SWITCHGEAR DEPARTMENT

GENERAL  ELECTRIC

PHILADELPHIA, PA.

POWER CIRCUIT BREAKER

TYPE AKF-2

ELECTRICALLY OPERATED MANUAL OPERATED

The instructions contained herein supplement Instruction Book GEI-50299 and are to be used in conjunction with it.

The AKF-2-25 breaker is a special type of AK-2 breaker. The design is intended to switch shunt field circuits of synchronous generators and synchronous motors. These breakers are usually furnished without series overcurrent tripping devices, and have a continuous rating of 600 amperes. The AKF is a two pole air circuit breaker with field discharge contacts located in the center pole position.

The closing of the field discharge contacts connects a field discharge resistor across the field winding of a generator or motor. This arrangement of main and discharge contacts allows the excitation circuit to open without inducing excessively high voltage in the field winding.

AKF-2
FIELD DISCHARGE MECHANISM
FIGURE 2

When an AKF-2-25 field breaker is opened, the field discharge contacts close before the main

contacts of the breaker open; on closing the field discharge contacts open after the main breaker contacts close. This contact overlap prevents opening the field circuit.

The outside pole contacts (1) close when the pin through eccentric bushing (12) is driven toward the pole base by the closing mechanism. The motion is transferred through eccentric bushing (12), link (10), link (14), crossbar (6) and the contact carrier pivoting about pivot pin (3).

Before the center pole contacts (7) open there is a moment of overlap when the center pole and outside poles are simultaneously closed. The motion to the center pole is transferred through eccentric bushing (12) link (10), link (14), cam follower (13), link (15), link (8), pin (20) and contact (7) pivoting about pivot pin (22).

The opposite operation of opening the outside pole contacts and closing the center pole contacts is effected by the same linkage with a reversal of motion.

The mechanism of the AKF-2-25 is a spring actuated over center toggle type of mechanism. Refer to GEI-50299 for description of the mechanism.

ADJUSTMENTS

The contact wipe on the outside poles is measured and adjusted by following the procedures of GEI-50299, Page 6 and 7. Proper contact wipe must be maintained between $3/32$ to $5/32$ of an inch.

The center pole is measured in the same manner as the outside poles, and must be maintained between $3/32$ to $5/32$ of an inch.

If the center pole contact wipe requires adjustment, three positions of contact wipe are obtainable by turning the eccentric bushings (12). The eccentric bushing (12) is shown in the center or nominal position. From this position, the eccentric bushing (12) can be turned 90 degrees in a clockwise direction to increase wipe or can be turned in a counter-clockwise direction to decrease wipe. To turn the bushings remove the tie bolt (11) and open up links (10) to expose the eccentric bushings (12).

NOTE: The pair of eccentric bushings (12) must be set to the same position before links (10) and tie bolt (11) are replaced.

Replace the links and tie bolt and measure contact wipes on center pole. The adjustment

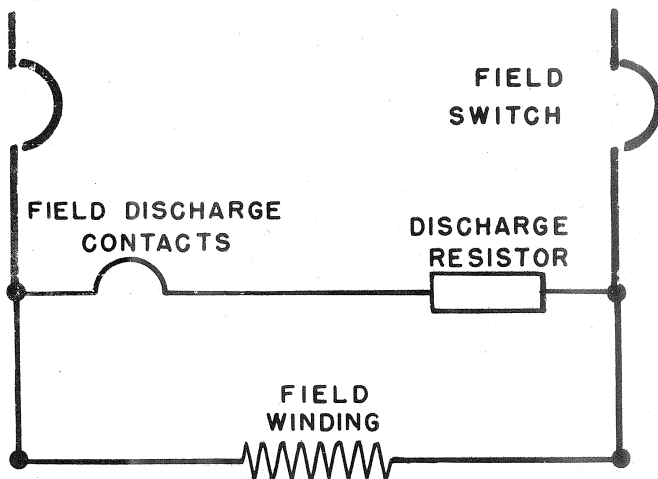
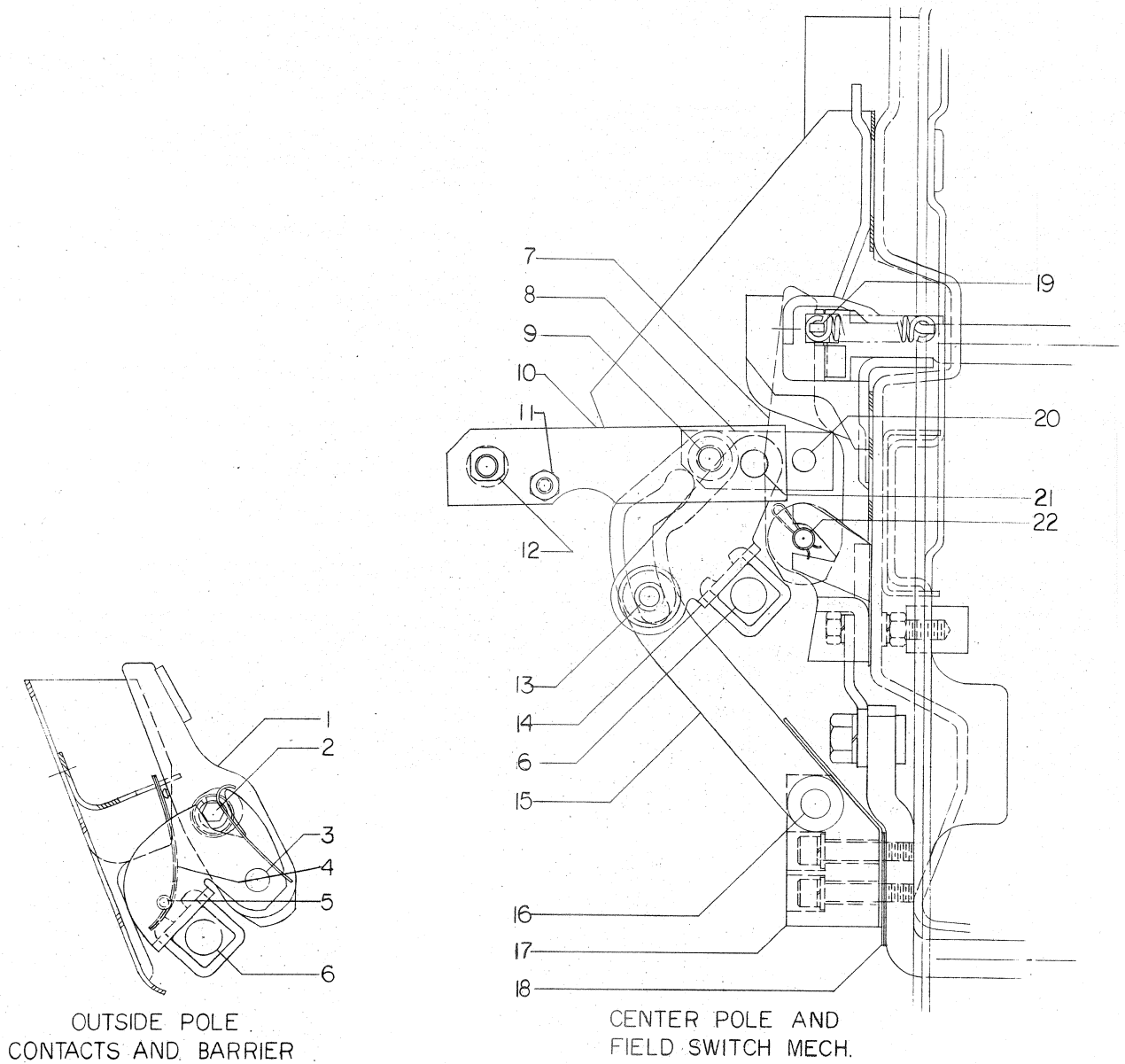

Fig. 1 (415A845) Typical Connection Diagram



- | | |
|----------------------------------|---------------------------------|
| 1 MOVABLE CONTACT- OUTSIDE POLES | 12 ECCENTRIC BUSHING-ADJUSTABLE |
| 2 ECCENTRIC PIN-ADJUSTABLE | 13 CAM FOLLOWER |
| 3 PIVOT PIN | 14 LINK AND CROSS BAR CLAMP |
| 4 SPRINGS | 15 LINK AND CAM |
| 5 PIN | 16 PIVOT PIN |
| 6 CROSS BAR | 17 LOWER PIVOT BLOCK |
| 7 MOVABLE CONTACT-CENTER POLE | 18 SHIMS |
| 8 LINK | 19 STATIONARY CONTACT |
| 9 PIN | 20 PIN |
| 10 LINK | 21 PIN |
| 11 TIE BOLT | 22 PIVOT PIN |

Fig. 2 (121C2873) Field Switch Mechanism and Contact Assemblies

obtainable from eccentric bushings (12) change the contact wipe on both the outside and center poles. Therefore, after obtaining the proper wipe on the center pole it is necessary to readjust the outside pole contact wipes by means of eccentric pin (2).

CONTACT OVERLAP (See Fig. 2)

Contact overlap is a factory setting that is obtained by adding or removing shims under the lower pivot block (14) during assembly. When the proper overlap is obtained the lower pivot block (14) is pinned at the factory and should not be changed in the field.

REPLACEMENTS

MOVABLE CONTACT SPRINGS (4) (See Fig. 2)

1. With contact (1) in the open position, take a screwdriver and push upward on the bottom of the "U" shaped springs (4) freeing them from pin (5) and contacts (1).
2. Remove the one end of pin (5) from its mounting in the contact carrier and slide new springs (4) into proper position.

NOTE: If springs (4) are not going to be changed at this time. They should be reformed to original shape before installing. To check springs place closed end of springs on a level table and measure the open end of springs to the table top. This dimension should be approximately 5/16 of an inch. Form springs until this dimension is obtained.

3. With spring (4) in proper position push down on pin (5) and slide pin (5) into its mounting hole in the contact carrier.

MOVABLE CONTACTS (1,7) (See Fig. 2).

1. Remove arc quencher (See "Replacement" under "Arc Quencher", page 6 of GEI-50299).
2. Remove operating mechanism (See "Replacement" under "Mechanism", page 10 of GEI-50299).
3. Remove movable contact springs (4) (see above).
4. Remove movable contacts (See "Movable Contacts" under "Contact Replacement", page 8 of GEI-50299).
5. Replace new contacts in reverse order.
6. Replace operating mechanism.
7. Adjust contact wipes. (See Adjustments).
8. Replace arc quenchers.

STATIONARY CONTACTS (19) (See Fig. 2).

1. Remove stationary contacts (See "Stationary Contacts" under "Contact Replacement", page 7 of GEI-50299).
2. Replace contacts in reverse order (See "Re-assembly" under "Contact Replacement", page 8 of GEI-50299).