



## INSTRUCTIONS

GEK-86132A  
SUPERSEDES GEK-86132

### POWER/VAC\* VACUUM CIRCUIT BREAKER WITH ML-18 MECHANISM

TYPES: □

VB1-4.16-250-1200A-58-0  
VB1-4.16-250-2000A-58-0

VB1-13.8-500-1200A-37-0  
VB1-13.8-500-2000A-37-0

VB1-13.8-500-1200A-58-0 Δ  
VB1-13.8-500-2000A-58-0 Δ

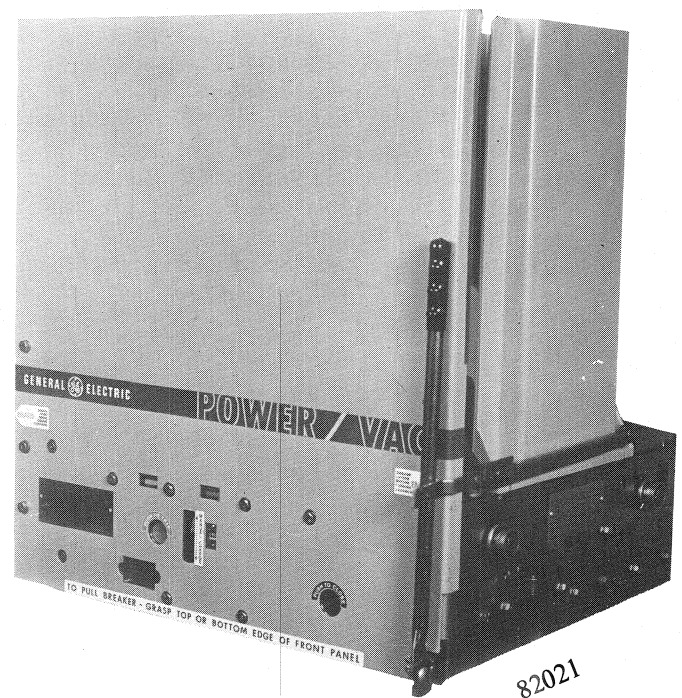

□ Vacuum Breaker — Nominal Voltage — Nominal MVA —  
Continuous Current — Close and Latch Kiloamperes — Model Designator  
(No number on breaker nameplate indicates -0 Model)

Δ Non-Standard High Close and Latch Ratings.

GENERAL  ELECTRIC

## LIST OF ILLUSTRATIONS

Figure No.		Page No.
1.	Shipping Block .....	6
2.	Front View of Power/ Vac* Breaker with Front Cover .....	7
3.	Front View of Power/ Vac* Circuit Breaker Without Front Cover .....	7
4.	Closing Spring Gag .....	8
5.	Manual Charging .....	8
6.	Toggle Linkage Positions of ML-18 Mechanism .....	10
7.	Erosion and Wipe Indicator .....	13
8.	Wipe Indicator .....	14
8A.	Mechanical Adjustments and Settings .....	16
9.	Schematic of ML-18 Mechanism .....	18
10.	Typical Wiring Diagram for ML-18 Mechanism .....	20
11.	Front and Left Side View of PV1 Breaker .....	21
12.	Rear and Right Side View of PV1 Breaker .....	21
13.	Trip Coil Adjustment .....	22
14.	Closing Coil Adjustment .....	23
15.	Bottom View of ML-18 Spring Charged Mechanism .....	24

## CONTENTS

	Page No.
Introduction .....	5
Safety .....	5
General .....	5
Specific .....	5
Description .....	5
Receiving, Handling and Storage .....	6
Receiving .....	6
Handling .....	6
Storage .....	6
Installation .....	7
Safety Precautions .....	7
Shipping .....	7
Mechanical Checking and Slow Closing .....	7
Electrical Checking .....	8
Operation .....	9
General .....	9
Close Spring Charging .....	9
Closing Operation .....	12
Opening Operation .....	12
Trip-Free Operation .....	12
Control Circuit .....	12
Interlocks .....	13
Mechanical Adjustments .....	14
General .....	14
Wipe Adjustment .....	14
Primary Contact Erosion Indication .....	25
Control Coil Plunger Travel .....	25
Control Switches .....	25
Electrical Checks .....	25
Control Power .....	25
Timing .....	25
Maintenance .....	26
General .....	26
Periodic Inspection .....	26

## CONTENTS (Con't.)

	Page No.
Maintenance (Cont.)	
Power/ Vac* Interrupter .....	26
Contact Erosion .....	26
Transfer Finger Wear .....	26
Insulation Tests .....	26
Vacuum Interrupter Integrity Test .....	27
Primary Circuit Resistance .....	27
Mechanism .....	27
Primary Insulation Parts .....	27
Lubrication .....	28
Recommended Maintenance .....	28
Repair and Replacement .....	28
General .....	28
Replacement of Interrupter .....	28
Primary Disconnect Fingers .....	29
Mechanism .....	29
Control Switches .....	29
Trip or Close Coils .....	29
Renewal Parts .....	29
Ordering Instructions .....	29
Recommended Renewal Parts .....	30

# POWER/VAC\* VACUUM CIRCUIT BREAKER WITH ML-18 MECHANISM

TYPES VB1-4.16-250  
TYPES VB1-13.8-500

## INTRODUCTION

To the extent required the products described herein meet applicable ANSI, IEEE and NEMA Standards; but no such assurance is given with respect to local codes and ordinances because they vary greatly.

### SAFETY

Each user has the responsibility to instruct all personnel associated with his equipment on all safety precautions which must be observed.

The following are recommendations to be considered in a user's safety program. These recommendations are not intended to supplant the user's responsibility for devising a complete safety program and shall not be considered as such. They are rather suggestions to cover the more important aspects of personnel safety related to circuit breakers. General Electric neither condones nor assumes any responsibility for user practices which deviate from these recommendations.

### GENERAL

1. All personnel associated with installation, operation and maintenance of power circuit breakers should be thoroughly instructed and supervised regarding power equipment in general and, also, the particular model of equipment with which they are working. Instruction books and service advices should be closely studied and followed.

2. Maintenance programs must be well planned and carried out consistent with both customer experience and manufacturer's recommendations including service advices and instruction books. Good maintenance is essential to breaker reliability and safety.

Local environment and breaker application must be considered in such programs, including such variables as ambient temperatures, actual continuous current, number of operations, type of interrupting duty, and any unusual local condition such as corrosive atmosphere or major insect problems.

### DESCRIPTION

The Power/Vac\* vacuum circuit breaker is a horizontal drawout removable and interchangeable interrupting element for use in metalclad switchgear to provide protection and control of electrical apparatus and power systems.

### SPECIFIC

1. DO NOT WORK ON AN ENERGIZED BREAKER. IF WORK HAS TO BE PERFORMED ON THE BREAKER, TAKE IT OUT OF SERVICE AND REMOVE IT FROM THE METALCLAD.

2. DO NOT WORK ON ANY PART OF THE BREAKER WITH THE TEST COUPLER ENGAGED.

3. All spring-charged mechanisms related to a breaker must be serviced only by skilled and knowledgeable personnel capable of releasing each spring load in a controlled manner. PARTICULAR CARE MUST BE EXERCISED TO KEEP PERSONNEL CLEAR OF MECHANISMS WHICH ARE TO BE OPERATED OR RELEASED. Information on construction of such mechanisms is provided in this instruction book.

4. Operational tests and checks should be made on a breaker after maintenance, before it is returned to service, to insure that it is capable of operating properly. The extent of such tests and checks should be consistent with the level of maintenance performed.

5. If maintenance on the Power/Vac\* breaker is being performed to an extended schedule such as on a 5 year or 10 year basis, it is recommended that the vacuum interrupter integrity test be performed each time the breaker is removed from the metalclad switchgear for reasons other than scheduled breaker maintenance if it has been more than one year since the last vacuum interrupter integrity test.

6. Interlocks are provided for the safety of the operator and correct operation of the breaker. If an interlock does not function as described DO NOT MAKE ANY ADJUSTMENT, MODIFICATION OR DISFIGURE THE PARTS. DO NOT FORCE THE DEVICE INTO POSITION; CONTACT THE NEAREST GENERAL ELECTRIC COMPANY INSTALLATION AND SERVICE OFFICE FOR INSTRUCTIONS.

The Power/Vac\* circuit breakers are available in continuous current ratings of 1200 and 2000 amperes in accordance with industry standards. A combination 1200/2000 ampere breaker is also available. Refer to the breaker nameplate for complete rating information of any particular breaker.

*These instructions do not purport to cover all details or variations in equipment nor to provide for every possible contingency to be met in connection with installation, operation or maintenance. Should further information be desired or should particular problems arise which are not covered sufficiently for the purchaser's purposes, the matter should be referred to the General Electric Company.*

*To the extent required the products described herein meet applicable ANSI, IEEE and NEMA standards; but no such assurance is given with respect to local codes and ordinances because they vary greatly.*

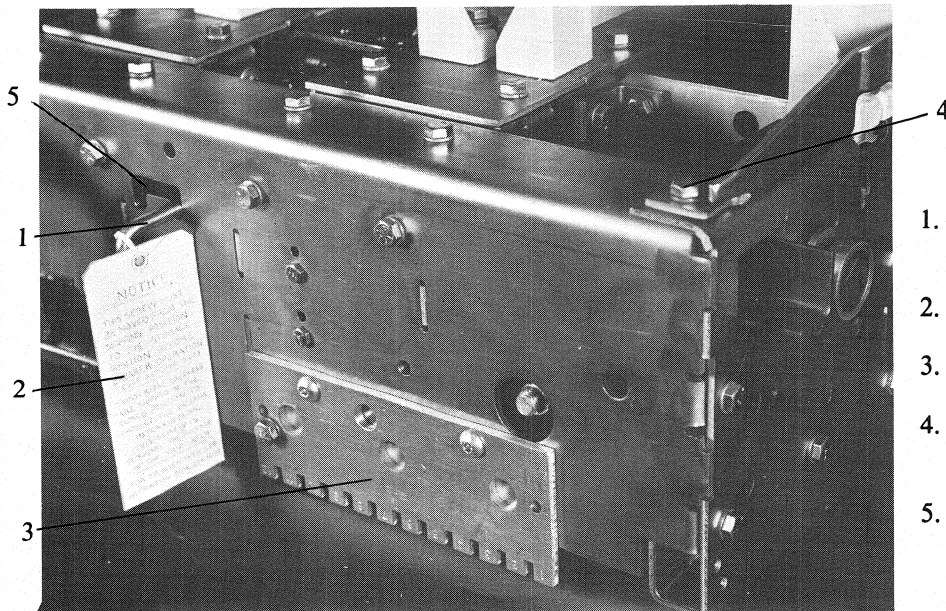

1. TRIP LATCH BLOCKING BOLT (BLOCKING POSITION)
2. YELLOW INSTRUCTION TAG
3. RATING INTERFERENCE BLOCK
4. LIFTING LOCATION (3/4 inch diameter hole @ all four corners)
5. TRIP LATCH BLOCKING BOLT (STORAGE LOCATION)

FIG. 1 SHIPPING BLOCK

82025

The nameplate also describes the control power requirements for that breaker. The application of a breaker must be such that its voltage, current and interrupting ratings are never exceeded. Since this book is written to include all ratings of the breaker, as well as several design variations, the instructions will be of a general character and all illustrations will be typical unless otherwise specified.

PROPER INSTALLATION AND MAINTENANCE ARE NECESSARY TO INSURE CONTINUED SATISFACTORY OPERATION OF THE BREAKER. The following instructions will provide complete information for placing Power/ Vac\* breakers in service and for maintaining satisfactory operation.

## RECEIVING, HANDLING AND STORAGE

### RECEIVING

Each breaker is carefully inspected before shipment. Immediately upon receipt of the circuit breaker, an examination should be made for any damage sustained in transit. If injury or rough handling is evident, a damage claim should be filed immediately with the transportation company and the nearest General Electric Sales Office should be notified.

It is expected that due care will be exercised during the unpacking and installation of the breaker so that no damage will occur from careless or rough handling, or from exposure to moisture or dirt. Check all parts against the packing list to be sure that no parts have been overlooked.

### HANDLING

When lifting the breaker use of the specially designed lift truck is recommended. It is necessary to use the truck when placing a breaker into or removing it from the metal-clad equipment. If it is necessary to lift the breaker with a hoist use four 1/2 inch diameter hooks rated at least 500 pounds each. Lifting locations are provided in the side frame members. See Figure 1. Use a spreader wider than the breaker to prevent slings from contacting the interrupter supporting insulating material parts.

A front swivel wheel and two rear wheels are provided for ease of movement on flat, level floors. When unattended

breakers are left on a floor or when a lift truck is used, block both rear wheels in both directions to prevent any accidental movement.

### STORAGE

It is recommended that the breaker be put into service immediately in its permanent location. If this is not possible, the following precautions must be taken to assure the proper storage of the breaker:

1. The breaker should be carefully protected against condensation, preferably by storing it in a warm dry room of moderate temperature such as 40° to 100° F. High humidity may have an adverse effect on the insulation parts and should be avoided. Circuit breakers for outdoor metalclad switchgear should be stored in the equipment only when power is available and the heaters are in operation to prevent condensation.

2. The breaker should be stored in a clean location, free from corrosive gases or fumes; particular care should be taken to protect the equipment from moisture and cement dust, as this combination has a very corrosive effect on many parts.

3. Rollers, latches, etc., of the operating mechanism should be coated with 0282A2048P009 grease to prevent rusting.

If the breaker is stored for any length of time, it should be inspected periodically to see that rusting has not started and to insure good mechanical condition. Should the breaker be stored under unfavorable atmospheric conditions, it should be cleaned and dried out before being placed in service.

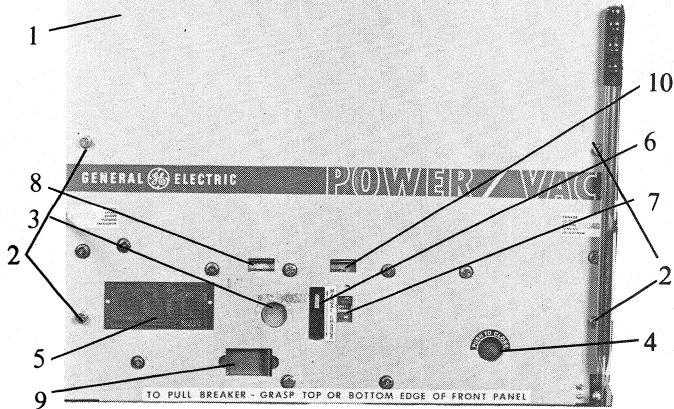

- |                         |                              |
|-------------------------|------------------------------|
| 1. Front Cover          | 6. Manual Charge             |
| 2. Cover Mounting Bolts | 7. Counter                   |
| 3. Manual Trip Button   | 8. Spring Charge Indication  |
| 4. Manual Close Button  | 9. Closing Spring Gag Access |
| 5. Nameplate            | 10. Open/Close Indicator     |

FIG. 2 FRONT VIEW OF POWER/VAC\* BREAKER WITH FRONT COVER

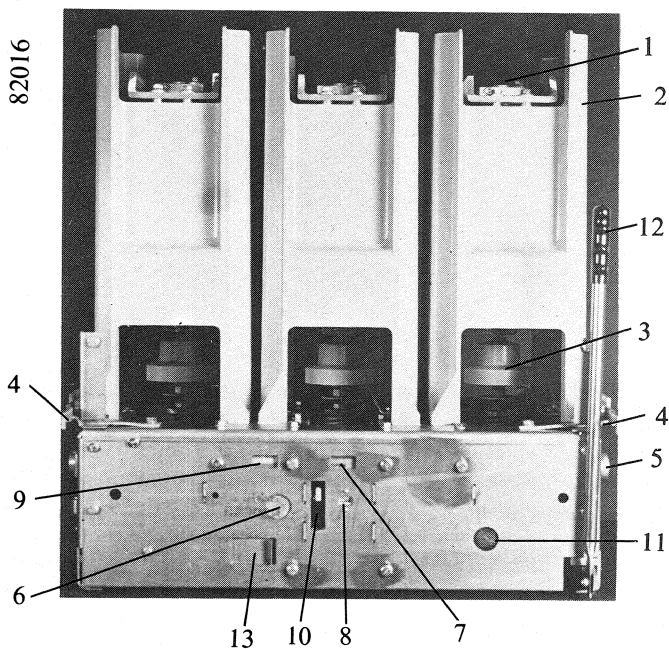

- |                                 |  |
|---------------------------------|--|
| 1. Upper Interrupter Connection | 8. Counter   |
| 2. Interrupter Support          | 9. Spring Charge Indicator                                   |
| 3. Operating Rod                | 10. Manual Charge  |
| 4. Racking Engagement Lever     | 11. Manual Close Button                                      |
| 5. Rollers for Track            | 12. Handle to Connect Secondary Disconnects in Test Position |
| 6. Manual Trip Button           | 13. Closing Spring Gag Access                                |
| 7. Open-Close Indicator         |  |

FIG. 3 FRONT VIEW OF POWER/VAC\* BREAKER WITHOUT COVER

## INSTALLATION

### SAFETY PRECAUTIONS

This circuit breaker uses powerful springs for energy storage. **DO NOT WORK ON THE INTERRUPTERS OR MECHANISM UNLESS BOTH THE CLOSING SPRINGS AND OPENING SPRINGS ARE EITHER DISCHARGED OR GAGGED AND ALL ELECTRICAL POWER IS REMOVED.** These precautions are required to prevent accidental operation. Anyone working on the circuit breaker should be familiar with the contents of this instruction book.

### SHIPPING

The circuit breaker has been shipped in the closed position with the mechanism trip latch blocked by a bolt through the rear frame. A yellow tag identifies this bolt (see Figure 1). (This bolt is in the storage position on breakers shipped inside the equipment.) Before operation or insertion into the metalclad equipment, this bolt must be relocated to the storage position (5, Fig. 1) and the mechanism tripped open with the manual trip push button. The close spring is shipped discharged. **DO NOT ATTEMPT TO TRIP THE BREAKER BEFORE RELOCATING THE BLOCKING BOLT.** (1, Fig. 1)

After removing packing material, locate and move to the storage position the trip latch blocking bolt indicated with a yellow tag on the rear plate of the mechanism. Press in on the manual trip push button (3, Fig. 2) to trip the mechanism open, keeping hands away from moving parts.

Closing and opening springs are now in their discharged positions. Check this by first pressing the manual close button, then the manual trip push buttons. The indicator flag on the front of the breaker should also show "OPEN" and "DISCHARGED".

### MECHANICAL CHECKING AND SLOW CLOSING

1. Visually inspect the circuit breaker for any signs of damage or loose hardware.

2. Manually charge the breaker closing spring using the charging handle provided (1, Fig. 5). The closing spring is charged by a ratcheting mechanism that advances by one ratchet tooth at a time. When the spring is fully charged and the spring load is held by the closing latch the spring indicator (8, Fig. 2) will change from "DISCHARGED" to "CHARGED", and a positive snap will be heard as the spring travels over center. After the spring is completely charged, as indicated above, *further forcing the charging handle may cause damage to the closing latch and its associated parts.*

3. Insert the closing spring gag plate (1, Fig. 4) by engaging the detents on the gag plate into the slots on the closing spring guide. Note that when the closing spring guide is exposed for gaging, an interference angle is exposed on the left side of the breaker (1, Fig. 11). This angle will provide interference preventing use of the lift truck and racking of the removable element with the closing spring in the blocked position. No attempt should be made to alter, modify or otherwise make inoperative this safety feature.

With the gag plate in position, depress the manual close button. This action will partially discharge the closing spring and also partially close the vacuum interrupter contacts. Do not energize the secondary control circuit at this time.

4. To manually slow-close the breaker contacts, insert the manual charging handle in the manual charge slot and move the handle up and down about 12 times until the closing roller (5, Fig. 6) is free from the closing cam and resting on the close prop (8, Fig. 6).

5. In the closed position, check and record the erosion indicator dimensions (4, Fig. 7) and the wipe indicator dimensions (5, Fig. 8). Check that the position indicator shows "CLOSED". See PRIMARY CONTACT WIPE (Page 14) AND EROSION INDICATOR (Page 25). Check the insulation resistance to ground by connecting a megohmmeter between the primary circuit and ground. The minimum resistance should be 10,000 megohms.

6. Keep clear and push the manual trip push button to trip the breaker open. Check that the position indicator shows "Open" and the operation counter advances one count.

7. Repeat (2) to charge the closing spring and then remove the closing spring blocking plate.

8. Discharge any stored energy in the breaker by successively depressing the manual close and manual trip buttons. Performing these operations leaves the breaker open with the closing spring discharged.

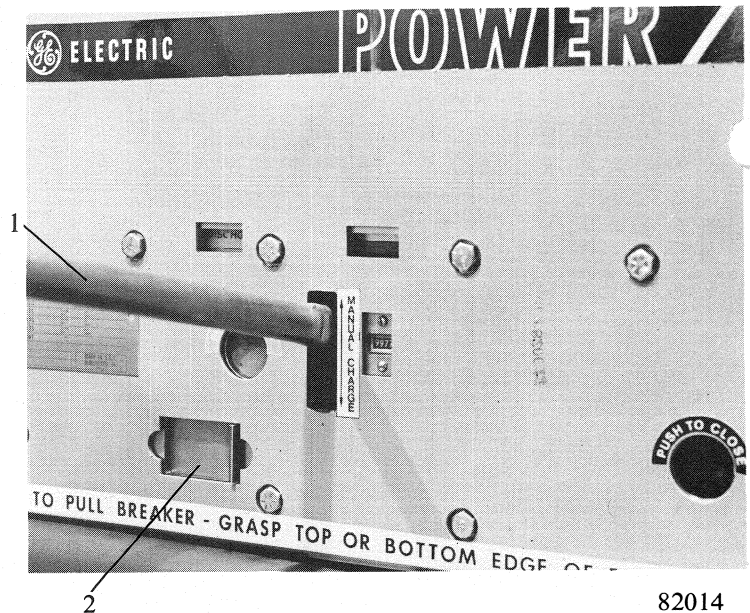

1. Manual Charging Handle
2. Closing Spring Gag Hole  
(Shown in blocked position)

FIG. 5 MANUAL CHARGING

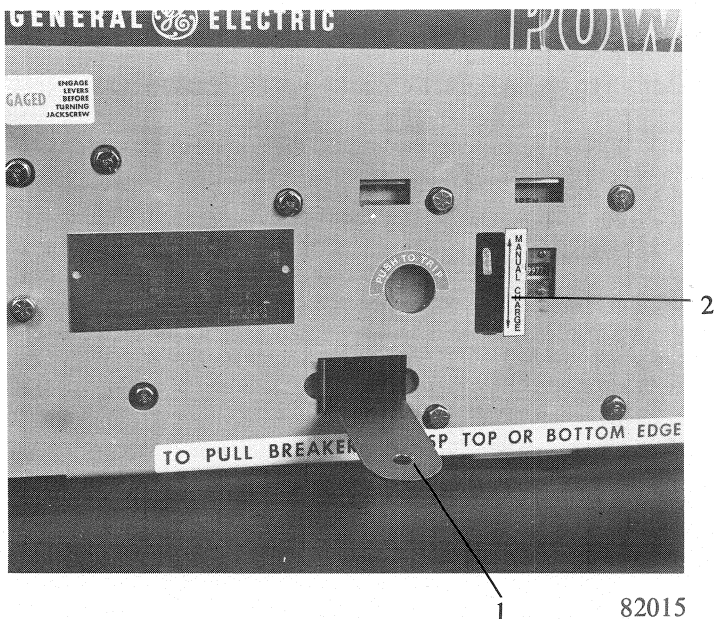

1. Closing Spring Gag Plate
2. Manual Charging Access

FIG. 4 MANUAL CHARGING

Electrical checking consists of electrical breaker operation, secondary wiring high-potential testing (if required), primary current path resistance (if required), Power/Vac\* interrupter high-potential testing, and insulation resistance to ground.

1. To check the electrical operation attach a secondary test coupler to the circuit breaker connector. Check the control voltage on the nameplate and close and open the breaker several times to check electrical operation.

2. Perform a vacuum interrupter integrity test to verify the condition of the interrupters. Perform the test as described under MAINTENANCE.

3. Leave the circuit breaker in an open and spring-discharged condition after checks are complete and refer to metalclad instruction book *GEK 39672*, before inserting the circuit breaker into a metalclad unit. Reinstall the front cover if it has been removed.



## OPERATION

### GENERAL

The Power/Vac\* vacuum circuit breaker uses a sealed vacuum power interrupter to establish and interrupt a primary circuit. Primary connections to the associated metal-clad switchgear are made by horizontal bars and disconnect fingers, electrically and mechanically connected to the vacuum interrupters. Molded supports, one per pole on a three-pole circuit breaker, provide interchangeable mountings for the primary bars, interrupters, current transfer fingers, and heat dissipation fins (where used). The operating mechanism provides vertical motion at each pole location in order to move the lower contact of the vacuum interrupters from an open position to a spring-loaded closed position and then back to the open position on command.

The ML-18 mechanism (Fig. 9) is of the stored-energy type and uses a gearmotor to charge a closing spring. During a closing operation, the energy stored in the closing spring is used to close the vacuum interrupter contacts, charge the wipe springs which load the contacts, charge the opening springs, and overcome bearing and other friction forces. The energy then stored in the wipe and opening springs will open the contacts during an opening operation.

Closing and opening operations are controlled electrically by the control switch on the metalclad or remote relaying. Mechanical control is provided by manual close and trip buttons on the circuit breaker. The closing spring may be manually charged, and a method for slow-closing the primary contacts is available. See **MECHANICAL CHECKING AND SLOW CLOSING**. The mechanism will operate at the a-c or d-c voltage indicated on the circuit breaker nameplate.

Mechanical and electrical interlocks are provided for safe operation and are described in this section under **INTERLOCKS**.

Figure 9 shows a front view of the ML-18 in a schematic form. The primary contacts are open and the closing springs charged. The closing spring charging system consists of a closing spring (1) mounted on the left side of the breaker and the electrical charging system mounted on the right side of the breaker. Both components are fastened to the cam shaft (2). A manual charging system (3) is provided so that the mechanism can be slow-closed and the closing spring can be charged if there is a loss of electrical control power.

### CLOSE SPRING CHARGING

Spring charging is accomplished electrically by a rotating eccentric on the output shaft of the gear motor driving pivoted charging arms (4, Fig. 9) that oscillate about the centerline of a ratchet wheel (5). A driving pawl (6), mounted within the charging arms, oscillates with the charging arms. Starting from its rear-most position, as the charging arms rotate forward, a spring forces engagement of the driving pawl with a tooth on the ratchet wheel. The ratchet wheel is advanced by the rotating charging arms and pawl assembly.

Advancement of one tooth spacing is provided for each oscillation of the system. The ratchet motion is restricted to one direction by a spring loaded holding pawl that prevents the ratchet wheel from going backwards as the charging arms oscillate back to pick up the next tooth. Thirteen (13)

complete cycles of the charging arms are needed for a full charge of the closing spring. The efficient, compact gear motor accomplishes this action in just about one (1) second.

When the charging cycle is complete the ratchet wheel is positioned so that a missing tooth is adjacent to the driving pawl and any motor overspin will not drive the ratchet wheel, thus preventing damage to the system.

When the spring is completely charged, the assembly is retained in that position until it is desired to close the circuit breaker.

The closing coil cannot be electrically energized unless the closing spring is completely charged. This action is prevented by the 52/CHG switch in the closing circuit.

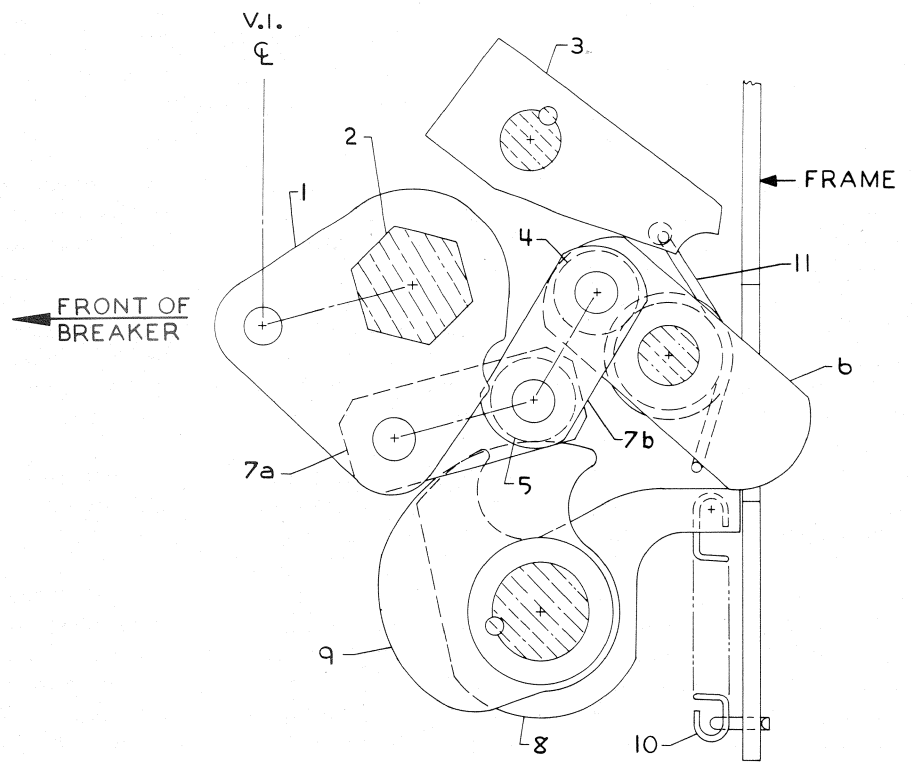

(A) BREAKER OPEN — SPRING DISCHARGED

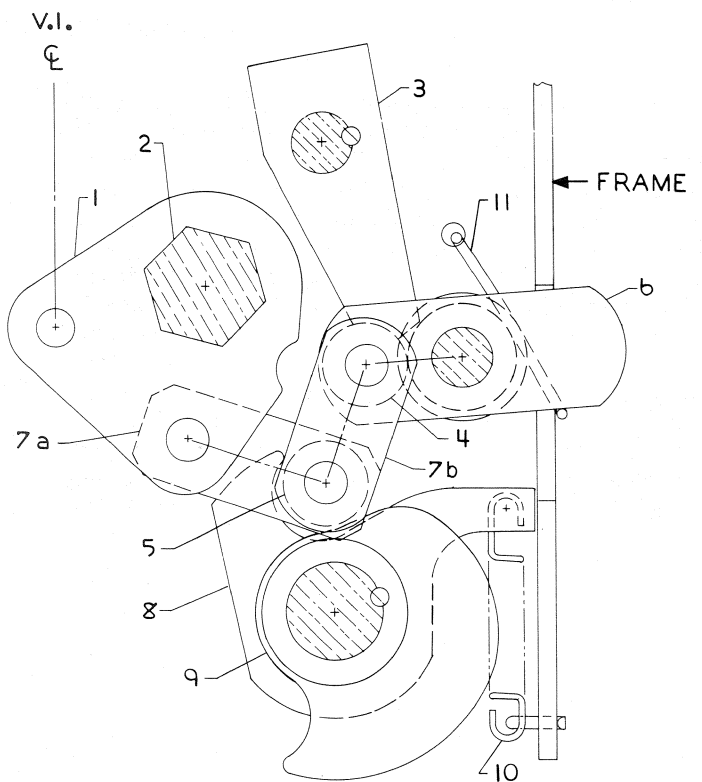

(B) BREAKER OPEN — SPRING CHARGED

- 1 OUTPUT CRANK
- 2 JACKSHAFT
- 3 TRIP LATCH
- 4 TRIP ROLLER
- 5 CLOSING ROLLER
- 6 TRIP LINK
- 7a CLOSING TOGGLE
- 7b CLOSING TOGGLE
- 8 PROP
- 9 CLOSING CAM
- 10 PROP SPRING
- 11 LINKAGE RETURN SPRING

Note: Shading indicates fixed pivots.

FIG. 6 TOGGLE LINKAGE POSITIONS OF THE ML-18 MECHANISM  
(VIEW FROM RIGHT HAND SIDE)

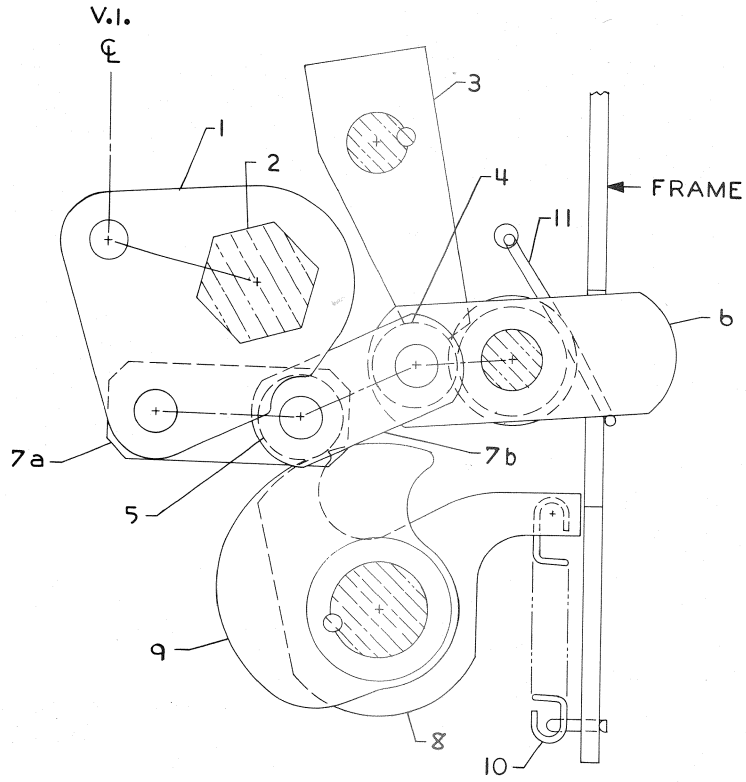

(C) BREAKER CLOSED — SPRING DISCHARGED

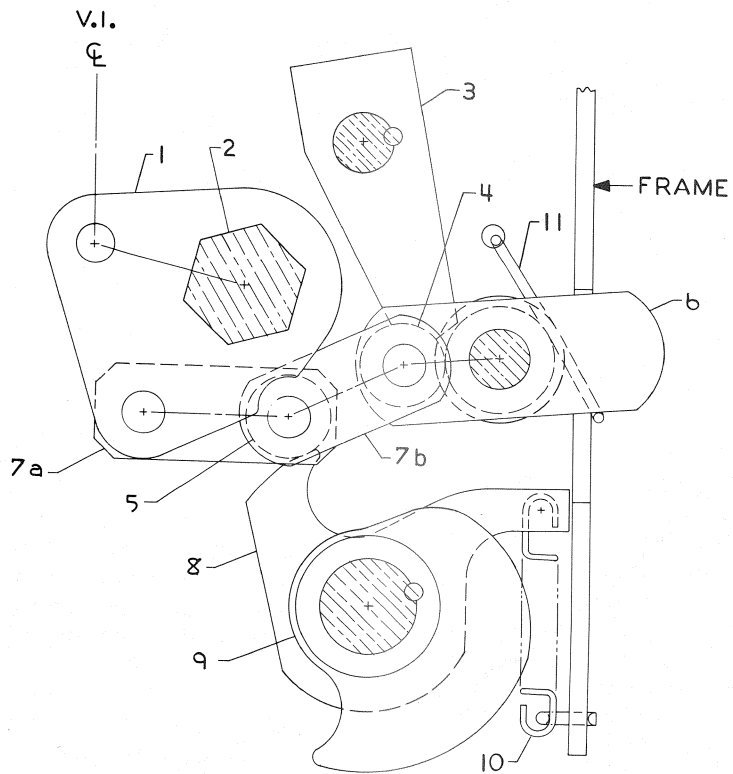

(D) BREAKER CLOSED — SPRING CHARGED

The manual charging system (3) works directly on the cam shaft where a one way clutch (7) driven by a manual handle provides rotation of the ratchet wheel. Manual pumping of the handle advances the ratchet wheel and the holding pawl prevents counter rotation while the handle is returning for another stroke. Six (6) to seven (7) complete strokes of the manual handle are required for one complete spring charging operation. When the spring charge indicator (9, Fig. 3) shows "CHARGED", MANUAL CHARGING MUST BE DISCONTINUED TO AVOID MECHANISM DAMAGE.

#### CLOSING OPERATION (REFER TO FIG. 9)

By either energizing the close solenoid or depressing the manual close button, the close latch (8) is rotated releasing the closing spring (1). This action is transmitted to the closing cam (9) and closing roller (10) and causes the linkage to rise until the prop (11) can slip under and hold the linkage in place. As the linkage moves the output crank (12) rotates the cross shaft (13) which in turn rotates the phase bell cranks (14) on all three poles. The rotation of the phase bell cranks compresses the two opening springs (15) on poles 1 and 3, closes the vacuum interrupters and compresses the wipe springs (16) on each interrupter. The rotation of the cross shaft (13) also changes the auxiliary switch (17) position and the position flag on the front panel will indicate "CLOSED". After the breaker is closed, the charging motor is again energized and the closing springs are charged as described under "CLOSE SPRING CHARGING". This is possible when the breaker is in the closed position because the linkage is held in position by the prop.

If the closing spring has not been recharged, the trip latch will be held out of position. A latch checking switch (21) will not close unless the latch is in its normal position. The contacts of latch checking switch are in the closing circuit so that electrically initiated closing is blocked when the trip latch is not reset.

#### TRIP-FREE OPERATION (REFER TO FIG. 9)

The linkage is mechanically trip-free in any location on the closing stroke. This means that energizing the trip coil while closing after the auxiliary switch contacts change position will rotate the trip latch and permit the circuit breaker to open fully. The linkage will reset as in a normal open operation and the closing spring will recharge as described under SPRING CHARGING.

#### CONTROL CIRCUIT

A typical Power/Vac\* circuit breaker ML-18 mechanism wiring diagram is shown in Fig. 10. Check the wiring diagram supplied with the actual circuit breaker for its wiring.

The close spring-charging-motor circuit is established through the CL/MS switch if the close latch is reset and the SM/LS switch if the closing spring is discharged. When the closing spring is charged, the SM/LS interrupts the circuit.

The close circuit is established through two normally closed Y relay contacts, 52Y and the latch-checking switch LC, if the trip latch is reset. An auxiliary switch contact 52

TABLE 1

NOMINAL CONTROL VOLTAGE	CHARGE MOTOR		CLOSE COIL		TRIP COIL	
	PART NO.	RANGE	PART NO.	RANGE	PART NO.	RANGE
48 VDC	0177C5050G003	38-56	0282A7015G001	38-56	0282A7015G004	28-56
125 VDC	0177C5050G001	100-140	0282A7015G002	100-140	0282A7015G006	70-140
250 VDC	0177C5050G002	200-280	0282A7015G003	200-280	0282A7015G007	140-280
115 VAC	0177C5050G001	104-127	0282A7015G004	104-127	N/A	----
230 VAC	0177C5050G002	208-254	0282A7015G005	208-254	N/A	----

#### OPENING OPERATION (REFER TO FIG. 9)

By either energizing the trip solenoid (18) or depressing the manual trip button, the trip latch (19) is rotated permitting the linkage to collapse and the vacuum interrupter contacts to open under the force of the wipe springs (16) and opening springs. At the end of the opening stroke a stop hits the frame and limits overtravel and rebound. Rotation of the cross shaft from the closed to an open position operates the auxiliary switch (17) and interrupts the trip coil current. If the closing spring has been recharged the linkage will be reset so that the trip latch will fall in place on the trip roller in preparation for another closing operation.

is also in series with the close coil and it closes when the breaker is open and opens when the breaker is closed. During a close operation, cam rotation closes the SM/LS contact, picking up the Y relay coil thereby opening its contacts to interrupt the close coil current and sealing it in through a normally open contact to the close signal. The sealing prevents reclosing on a sustained close command as the close signal must be removed to drop out the Y relay, and re-establish the closing circuit, thereby providing an anti-pump feature.

Circuit breaker mounted auxiliary switch contacts not used in the control circuit are brought out for control and indication functions. The metalclad equipment may provide a breaker operated stationary auxiliary switch for additional contacts.

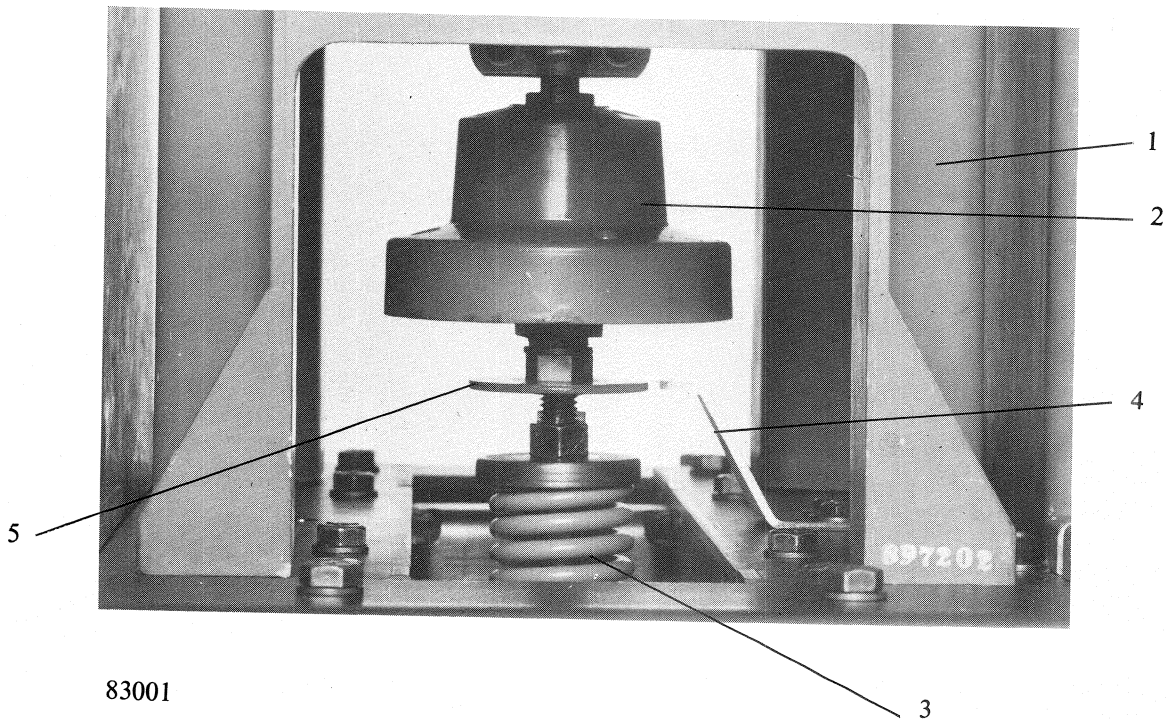

83001

1. Interrupter Support
2. Operating Rod Insulator
3. Wipe Spring
4. Erosion Indicator
5. Erosion Disk  
(Shown in closed position  
with no contact erosion)

FIG. 7 EROSION INDICATOR  
INTERLOCKS

Each Power/Vac\* vacuum circuit breaker is provided with the following interlocks.

(1) Rating interference plate (7, Fig. 12) permits only a breaker of the matching continuous current, voltage and interrupting MVA rating to be inserted into a metalclad compartment.

The combination 1200/2000 ampere breaker can be used in either a 1200 or a 2000 ampere compartment. The rating interference plate must be adjusted to match the current rating of the compartment. This is done by positioning the outer interference plate so that the edge of the plate lines up with the current indicated on the label attached to the breaker just above the rating interference plate.

(2) The function of the closing spring discharge interlock is to prevent racking into or withdrawing from the metalclad a breaker that has the closing spring charged. This is accomplished by a roller (4 Fig. 12) on the right-hand side of the mechanism which contacts the racking mechanism and discharges the closing spring unless the breaker is in the "Disconnect/Test" position or the "Connect" position in the metalclad. This interlock also opens the CL/MS switch in the motor charging circuit to prevent charging the closing springs when the breaker is between the "Disconnect/Test" or "Connect" position in the metalclad.

(3) The function of the NEGATIVE TRIP INTERLOCK (5, Fig. 11) is to remove the trip latch from the trip latch roller thereby preventing a closing operation. The interlock also opens the latch checking switch in the closing circuit thereby removing the close circuit power. The negative interlock is in operation while the breaker is moving between the "Disconnect/Test" position and the "Connect" position.

(4) The positive interlock (3, Fig. 11) operates to prevent the racking of a breaker that is closed. A linkage connected to the cross shaft extends a detent bar (3) out from the side of the mechanism frame when it is in the closed position. If the breaker is in the "Connect" or "Disconnect/Test" position in the metalclad the detent bar locks into the racking mechanism to prevent access to the hex section of the jack screw.

(5) The closing spring gag interlock is provided on the breaker to prevent a breaker that has a gagged closing spring from entering the metalclad unit. This is accomplished by projecting an angle (1) out of the left side of the mechanism when the closing spring is gagged. See Fig. 11.

(6) Trip Latch Block.

## MECHANICAL ADJUSTMENTS

### GENERAL

The ML-18 Mechanism has been designed for extended intervals between maintenance. In most cases only the wiper and gap adjustments will require re-setting throughout the life of the circuit breaker. In addition to the descriptions of the mechanical adjustments, Table 2 contains a summary of adjustment settings as well as additional measurements to be checked for proper functioning of the interlocks.

### WIPE ADJUSTMENT

Wipe is the additional compression of a preloaded spring, used to apply force to the vacuum interrupter contacts and to provide opening kick-off force.

An indicator is provided on the wiper spring assembly with graduations given in 0.050 inch on which the wipe is indicated directly. See Figure 8.

Improvement in the accuracy of the wiper measurement may be obtained by using a feeler gauge between the wiper indicator and the erosion disc. The difference in readings recorded on each pole with the breaker closed and open will be the contact wipe.

The wiper should be set as follows:

Breaker Rating	Wipe (inches)
13.8-500	0.155-0.180
Readjust when reduced to 0.075	
4.16-250	0.155-0.180
Readjust when reduced to 0.075	

To adjust the primary contact wiper, close the breaker and block the trip latch with the trip latch blocking rod (6), Figure 12. This will prevent injury from accidental opening of the breaker.

(1) Loosen but do not remove the two screws (6), Figure 8, holding the interrupter clamp.

(2) Check that the interrupter clamp is loose. A light pry at the clamp half junction may be required to loosen the wedging action of the clamp.

(3) Hold the hexagon projection (9), Figure 8, at the bottom of the operating rod insulator (1 inch wrench) and loosen the adjacent locknut ( $\frac{3}{4}$  inch wrench). Refer to (8), Figure 8. Adjust by rotating the operating rod insulator. The thread is  $\frac{1}{2}$ -13 and each turn will give about 0.078 inch change in primary wiper. Screw the operating rod insulator toward the interrupter to increase wiper.

(4) After setting the contact wipers on each phase torque the operating rod locknut (8), Figure 8, to 40-50 foot pounds while preventing the operating rod insulator (2) from turning. Tighten the clamp screws (6) to 10-12 foot pounds. Remove the trip shaft block and trip the breaker open. This procedure prevents accidental twisting of the operating rod of the interrupter by loading the contacts with the wiper springs and forcing relative rotation to occur at the clamp interface.

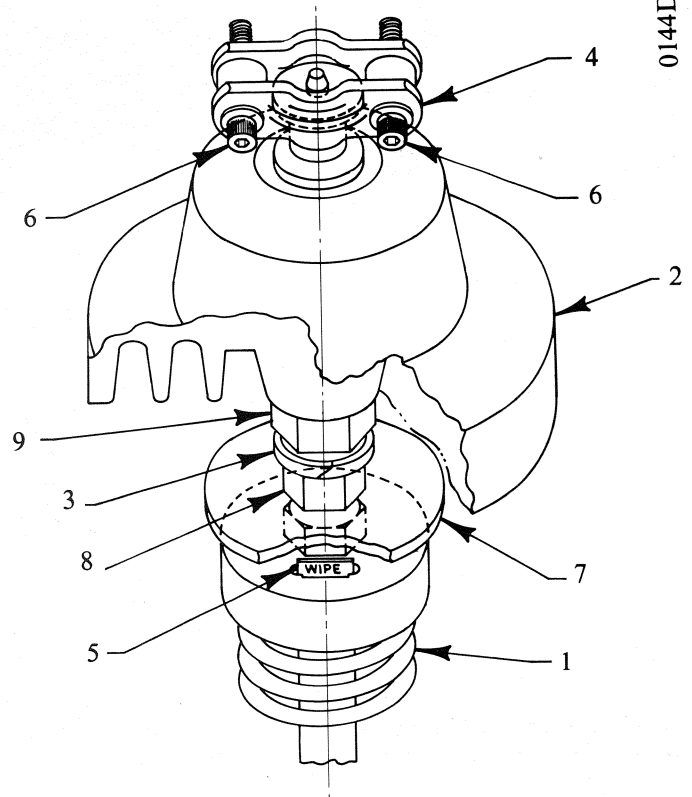

FIG. 8 WIPE INDICATOR

1. WIPE SPRING
2. OPERATING ROD INSULATOR
3. LOCK WASHER
4. INTERRUPTER CLAMP
5. WIPE INDICATOR
6. CLAMP SCREWS
7. EROSION DISK
8. LOCK NUT
9. HEXAGON PROJECTION

After adjustment, remeasure the wipers to check the adjustment. If the wiper settings are within the required limits, there is an adequate contact closing relationship between the poles.

0144D1299-3

ITEM SEE FIG. 8A	BREAKER POSITION	CLOSING SPRING	OPENING SPRING	TRIP LATCH	ADJUSTMENT DETAIL
1. TRIP COIL	CLOSED	DISCHARGED	CHARGED	UNBLOCKED	1. DEPRESS PLUNGER WITH A .19 SPACER (EXAMPLE: .19 DRILL) PLACED BETWEEN PLUNGER BASE AND COIL HOUSING. 2. TURN ADJUSTING NUT UNTIL TRIP PIN MAKES CONTACT WITH TRIP ARM.
2. CLOSE LATCH	OPEN	CHARGED	DISCHARGED	UNBLOCKED	1. ADVANCE ADJUSTING SCREW UNTIL BREAKER CLOSES. 2. BACK ADJUSTING SCREW OFF 1/2 TURN. 3. CHECK ELECTRICAL CLOSE/CHARGE.
3. CLOSE COIL	OPEN	CHARGED	DISCHARGED	UNBLOCKED	1. DEPRESS PLUNGER WITH A .19 SPACER EXAMPLE: .19 DRILL) PLACED BETWEEN PLUNGER BASE AND COIL HOUSING. 2. TURN ADJUSTMENT NUT UNTIL CLOSE LATCH ACTUATOR MAKES CONTACT WITH CLOSE LATCH.
4. SPRING DISCHARGE INTERLOCK	OPEN	CHARGED	DISCHARGED	UNBLOCKED	1. GAGED .840 DIM WITH ADJUSTING SCREW BACKED OFF. 2. ADVANCE ADJUSTING SCREW TO MAKE CONTACT WITH LEVER. 3. CHECK THAT SPRING DISCHARGES AT .561 MIN. DIM. 4. CLOSE LATCH MUST RESET AS INDICATED.
5. OPENING SPRING	AS REQ'D.	AS REQ'D.	AS REQ'D.	UNBLOCKED	1. SET ADJUSTING NUT SO THAT OPENING SPEED IS APPROX. 5.0 FT/SEC. (MUST BE GREATER THAN 3.5 FT/SEC) AND CLOSING SPEED IS APPROX. 2.75 FT/SEC (MUST BE LESS THAN 4.0 FT/SEC).
6. WIPE	CLOSED	CHARGED & GAGGED	CHARGED	BLOCKED	1. CLOSE BREAKER. (LINKAGE MUST BE ON PROP LATCH). FIG. 6D 2. BACK OFF OPERATING ROD UNTIL CONTACTS ARE SEPARATED. 3. WITH BUZZER ACROSS CONTACTS, ADVANCE OP. ROD UNTIL CONTACTS TOUCH. 4. ADVANCE OP. ROD 2½ ADDITIONAL TURNS. 5. LOCK LOCK NUT. 6. CHECK WIPE — MUST BE .155 - .180 (SET ALL 3 PHASES BEFORE MEASURING). 7. IF REQUIRED, ADJUST TO FINE TUNE.
7. GAP	OPEN	CHARGED OR DISCHARGED	DISCHARGED	UNBLOCKED	1. SET ADJUSTING NUT SO THAT GAP IS .545 - .600. 2. CHECK THAT TRIP LATCH WILL RESET. 3. ADJUST GAP IF TRIP LATCH WILL NOT RESET.
8. N.O. SWITCHES	AS REQ'D.	—	—	—	1. ADJUST SWITCH FOR RECESS SHOWN WHEN PLUNGER IS DEPRESSED (CONTACTS CLOSED).

TABLE 2 SUMMARY OF ADJUSTMENTS AND CRITICAL DIMENSIONS

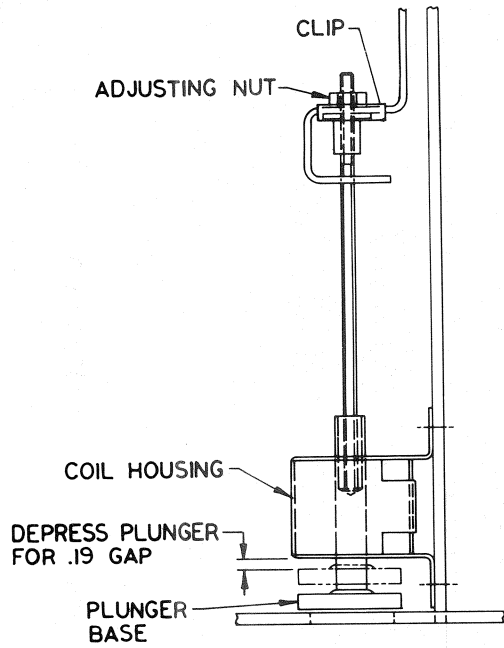
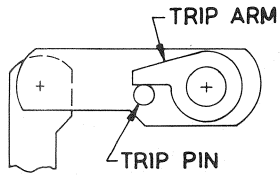

TRIP COIL  
SEE TABLE 2 — ITEM 1

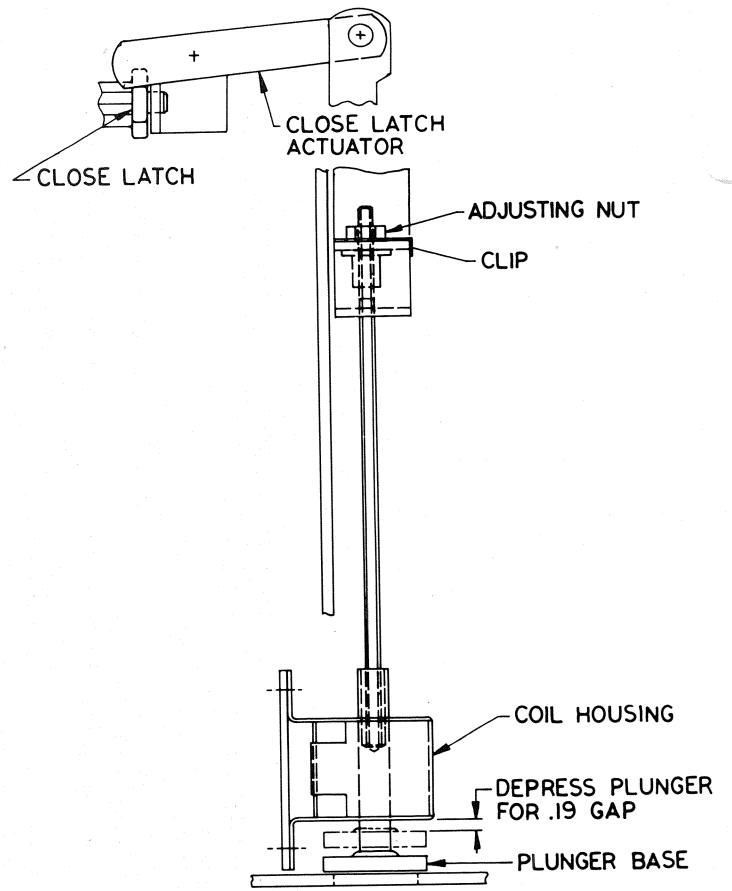

CLOSE COIL  
SEE TABLE 2 — ITEM 3

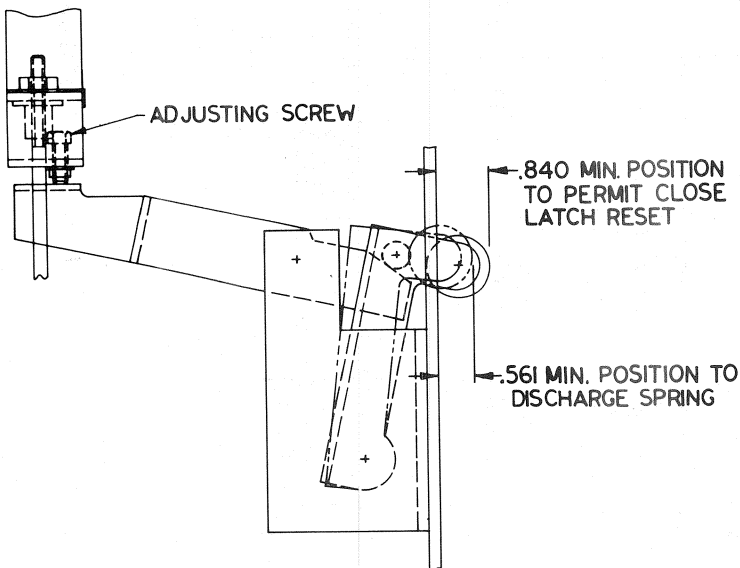

SPRING DISCHARGE INTERLOCK  
SEE TABLE 2 — ITEM 4

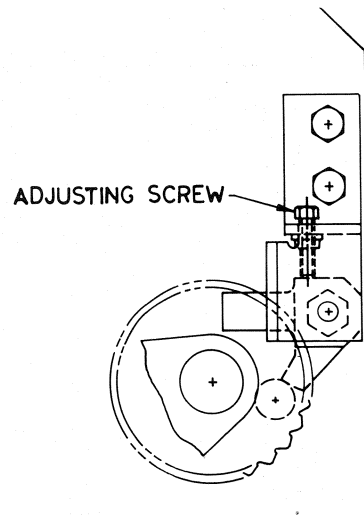

CLOSE LATCH  
SEE TABLE 2 — ITEM 2



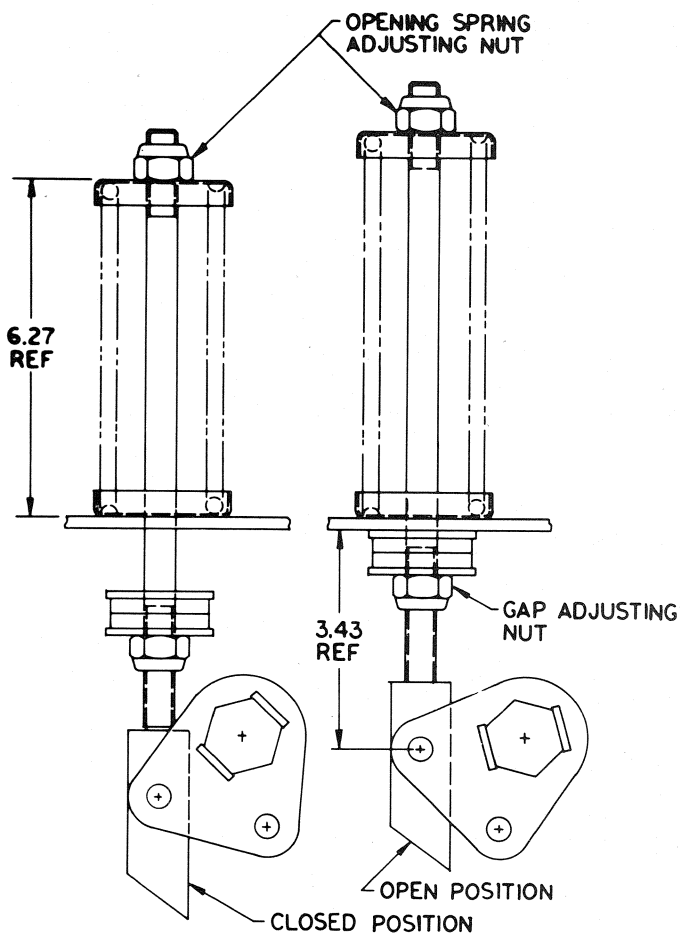

OPENING SPRING SEE TABLE 3 — ITEM 5

GAP SEE TABLE 2 — ITEM 7

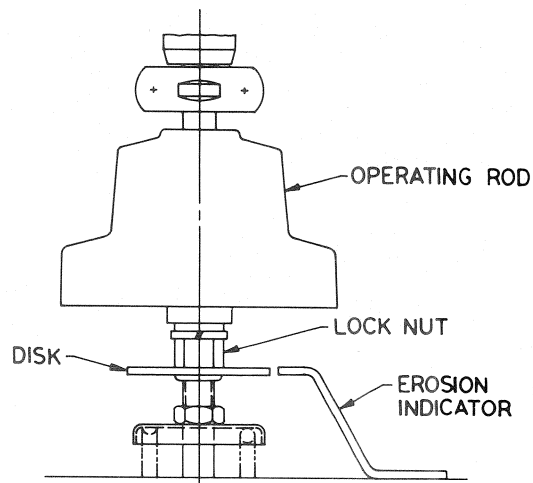

WIPE SEE TABLE 2 — ITEM 6  
EROSION INDICATOR

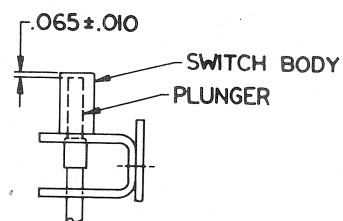

N.O. SWITCHES  
SEE TABLE 2 — ITEM 8

FIG. 8A  
MECHANICAL  
ADJUSTMENTS  
AND  
SETTINGS

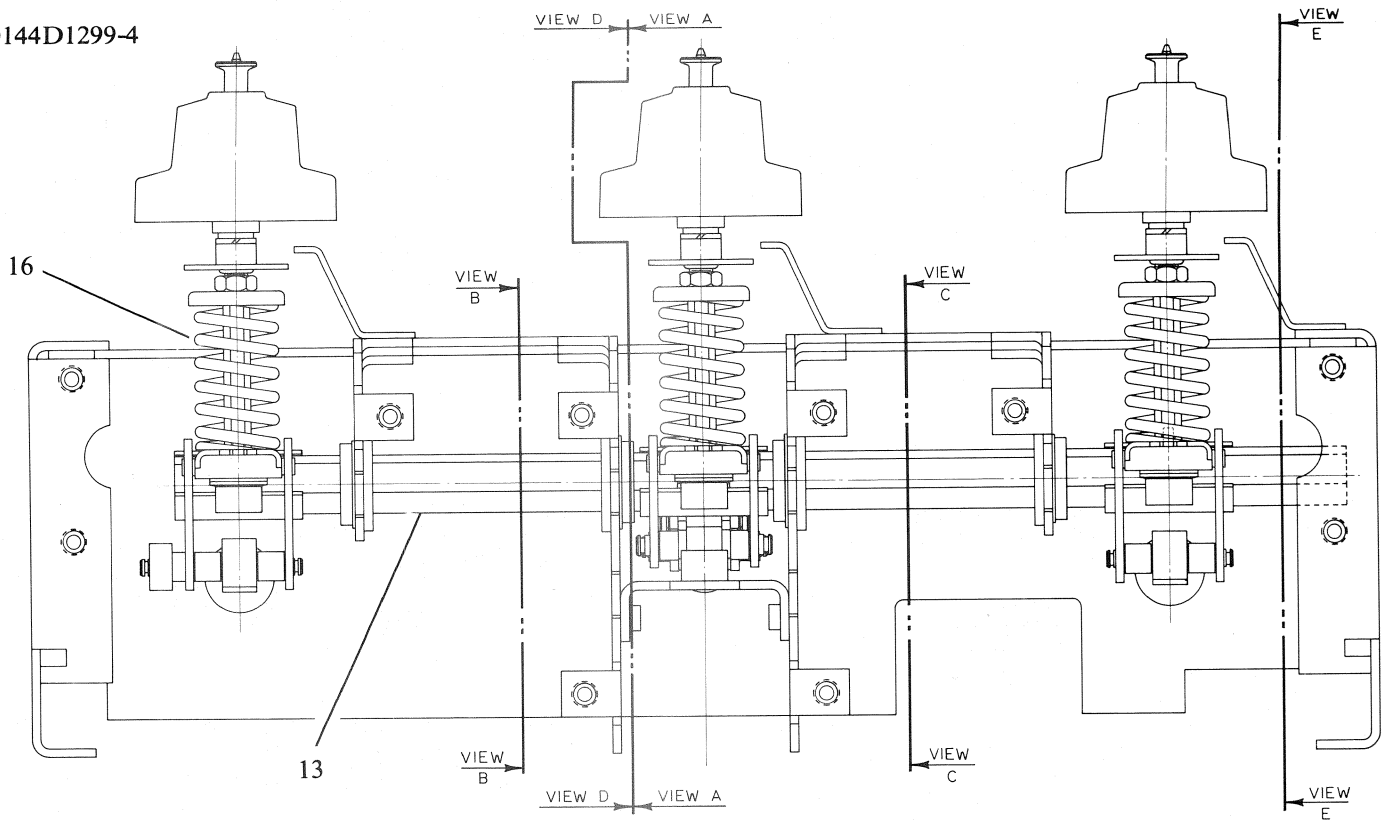
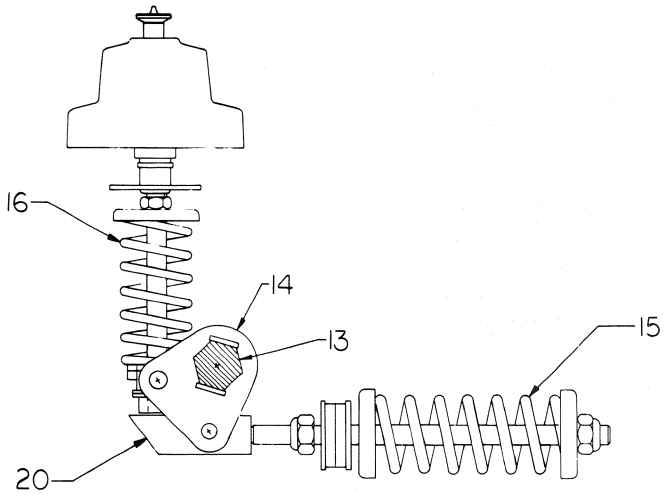

FIG. 9 SCHEMATIC OF ML-18 MECHANISM

- |                   |                        |
|-------------------|------------------------|
| 1. CLOSE SPRING   | 12. OUTPUT CRANK       |
| 2. CAM SHAFT      | 13. CROSS SHAFT        |
| 3. MANUAL CHARGE  | 14. BELL CRANKS        |
| 4. CHARGING ARMS  | 15. OPENING SPRINGS    |
| 5. RATCHET WHEEL  | 16. WIPE SPRINGS       |
| 6. DRIVING PAWL   | 17. AUX. SWITCH        |
| 7. ONE-WAY CLUTCH | 18. TRIP SOLENOID      |
| 8. CLOSE LATCH    | 19. TRIP LATCH         |
| 9. CLOSE CAM      | 20. OVER-TRAVEL STOP   |
| 10. CLOSE ROLLER  | 21. LATCH CHECK SWITCH |
| 11. PROP          | 22. GEAR MOTOR         |

0144D1299-5,6



PARTIAL VIEW — E

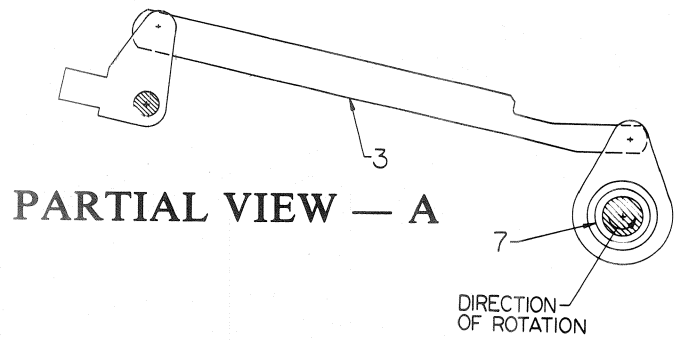

PARTIAL VIEW — A

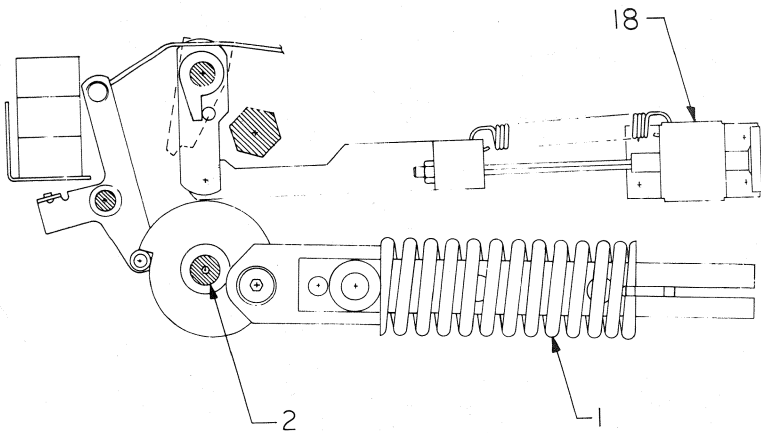

PARTIAL VIEW — B

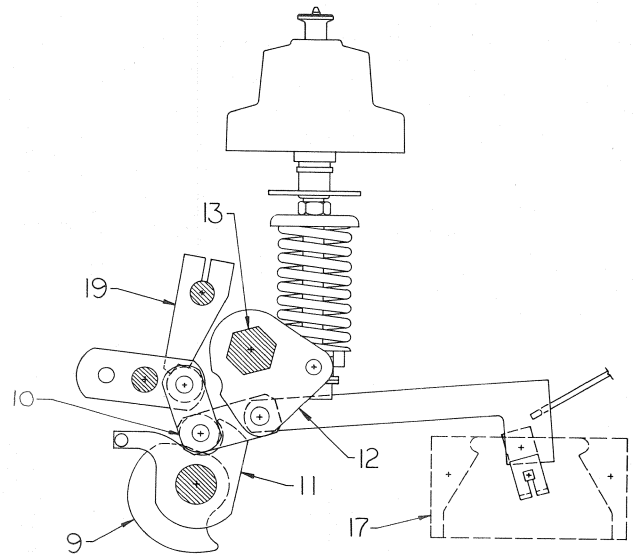

PARTIAL VIEW — D

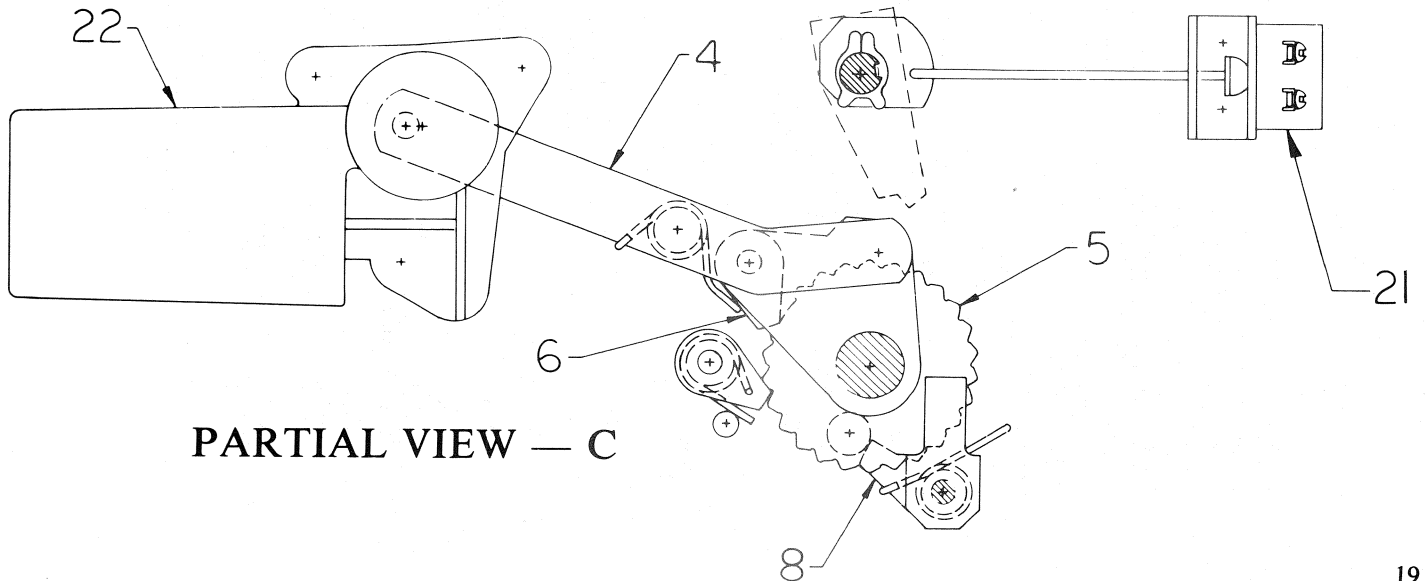

PARTIAL VIEW — C

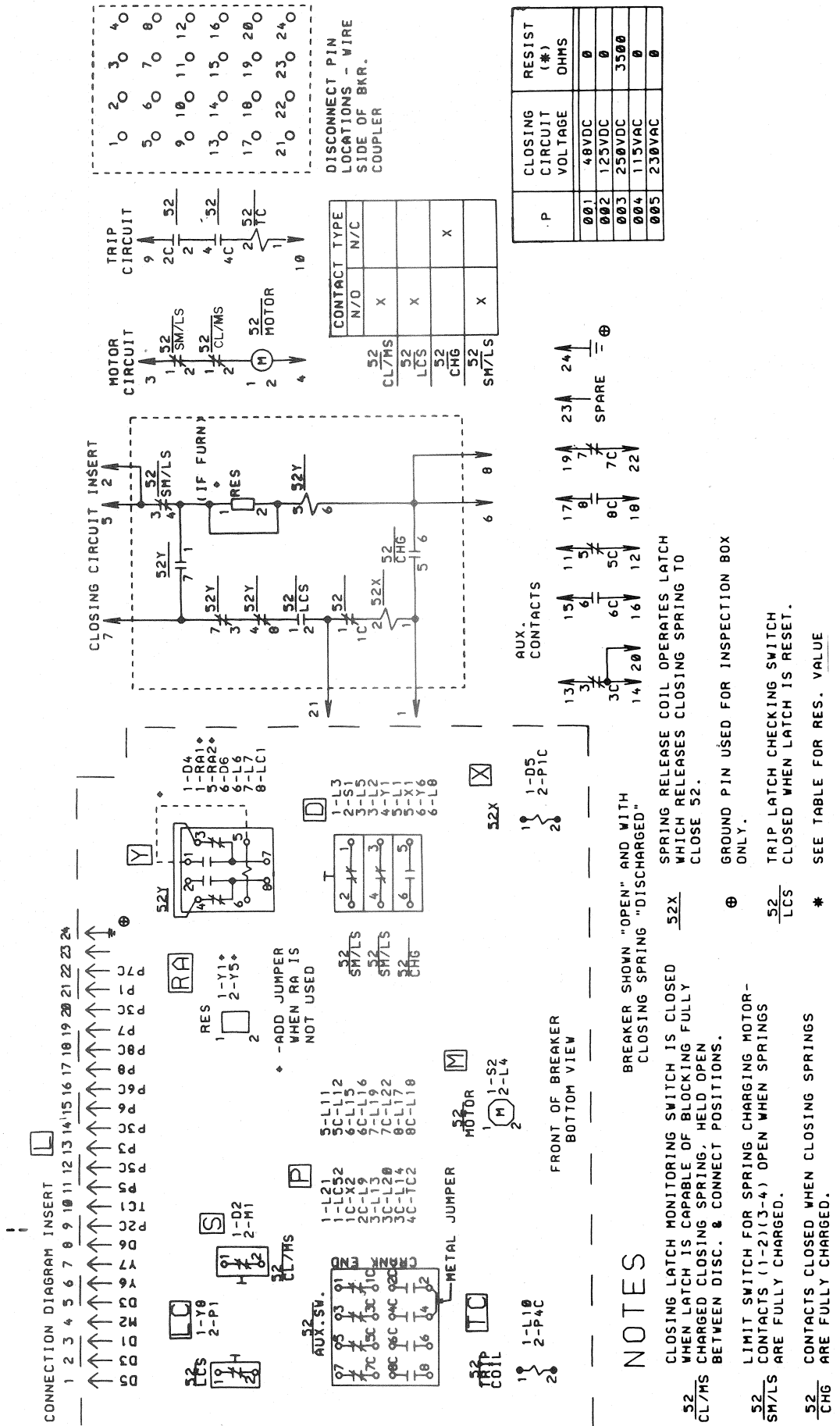
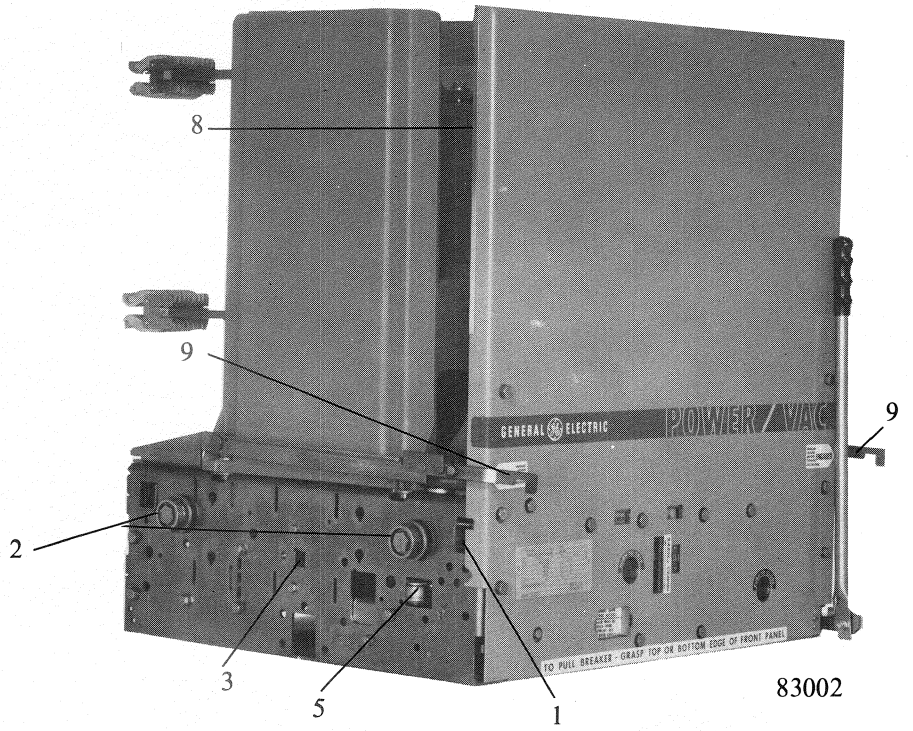

FIG. 10 TYPICAL WIRING DIAGRAM ML-18 MECHANISM

0209B8199-1

**NOTES**

- 52 CLOSING LATCH MONITORING SWITCH IS CLOSED WHEN LATCH IS CAPABLE OF BLOCKING FULLY CL/MS CHARGED CLOSING SPRING, HELD OPEN BETWEEN DISC. & CONTACT POSITIONS.
- 52 LIMIT SWITCH FOR SPRING CHARGING MOTOR- CONTACTS (1-2)(3-4) OPEN WHEN SPRINGS ARE FULLY CHARGED.
- 52 CONTACTS CLOSED WHEN CLOSING SPRINGS ARE FULLY CHARGED.
- BREAKER SHOWN "OPEN" AND WITH CLOSING SPRING "DISCHARGED"
- SPRING RELEASE COIL OPERATES LATCH WHICH RELEASES CLOSING SPRING TO CLOSE 52.
- ⊕ GROUND PIN USED FOR INSPECTION BOX ONLY.
- 52 TRIP LATCH CHECKING SWITCH CLOSED WHEN LATCH IS RESET.
- \* SEE TABLE FOR RES. VALUE



1. GAG INTERLOCK ANGLE
2. TRACK ROLLERS
3. POSITIVE INTERLOCK BAR
4. CLOSING SPRING DISCHARGE ROLLER
5. NEGATIVE INTERLOCK ROLLER
6. TRIP LATCH BLOCKING ROD
7. RATING INTERFERENCE PLATE
8. FRONT COVER
9. RACKING ENGAGEMENT LEVER
10. SECONDARY COUPLER

FIG. 11 PV1 BREAKER — FRONT AND LEFT SIDE VIEW

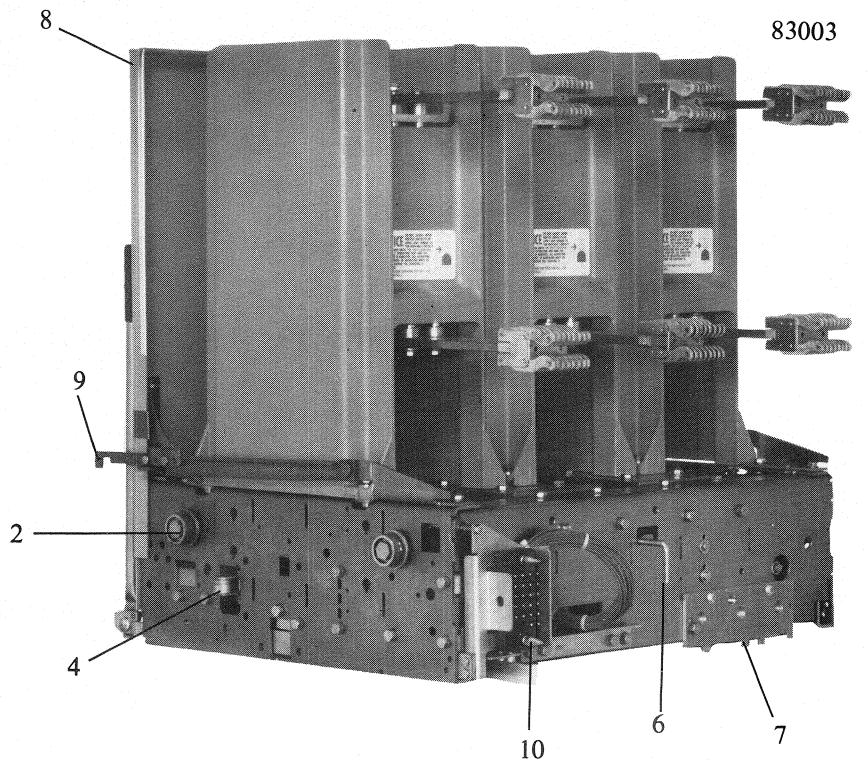
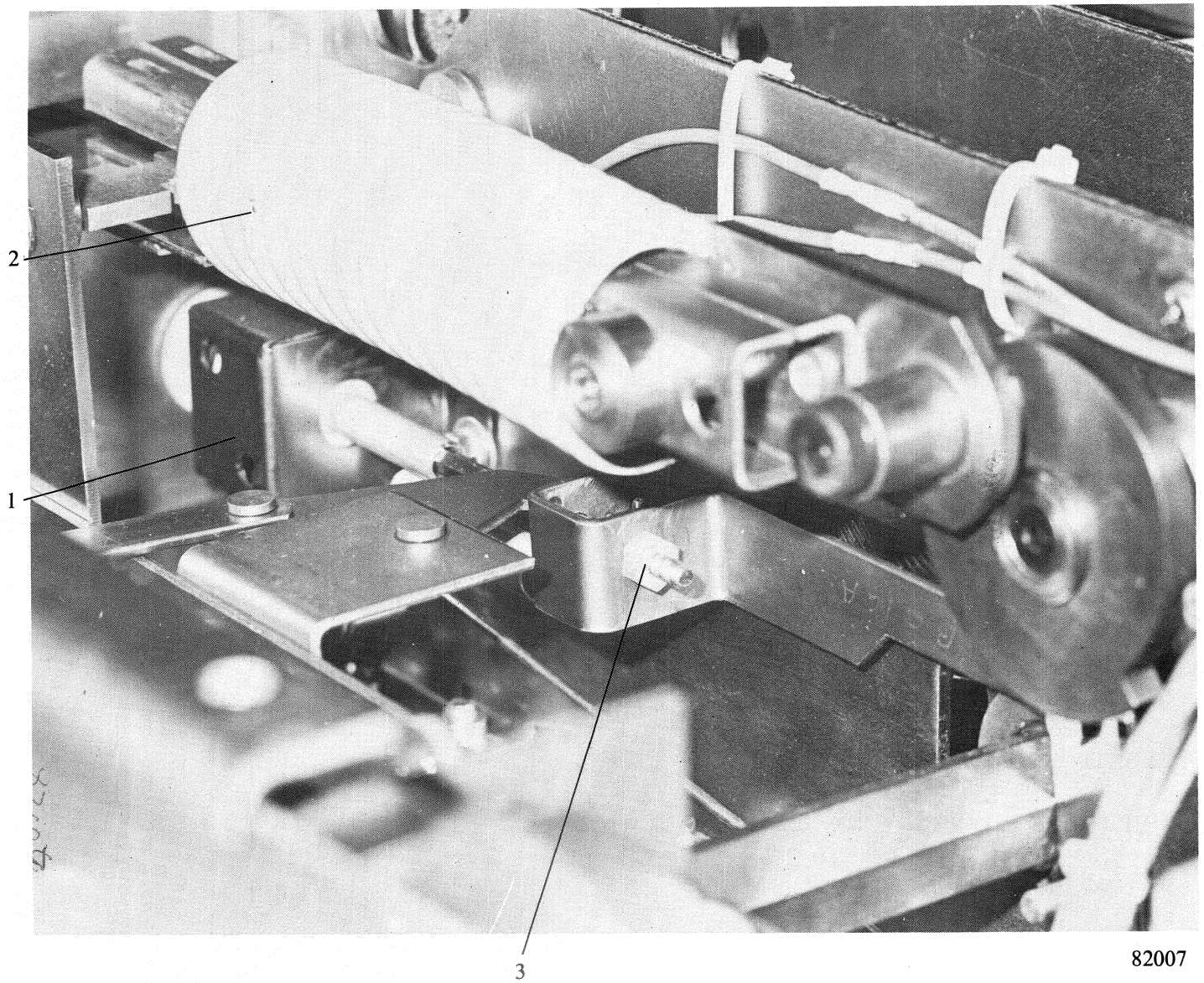

FIG. 12 PV1 BREAKER — REAR AND RIGHT SIDE VIEW



82007

FIG. 13 TRIP COIL ADJUSTMENT

1. TRIP COIL
2. CLOSING SPRING
3. TRIP COIL ADJUSTING  
SCREW AND NUT

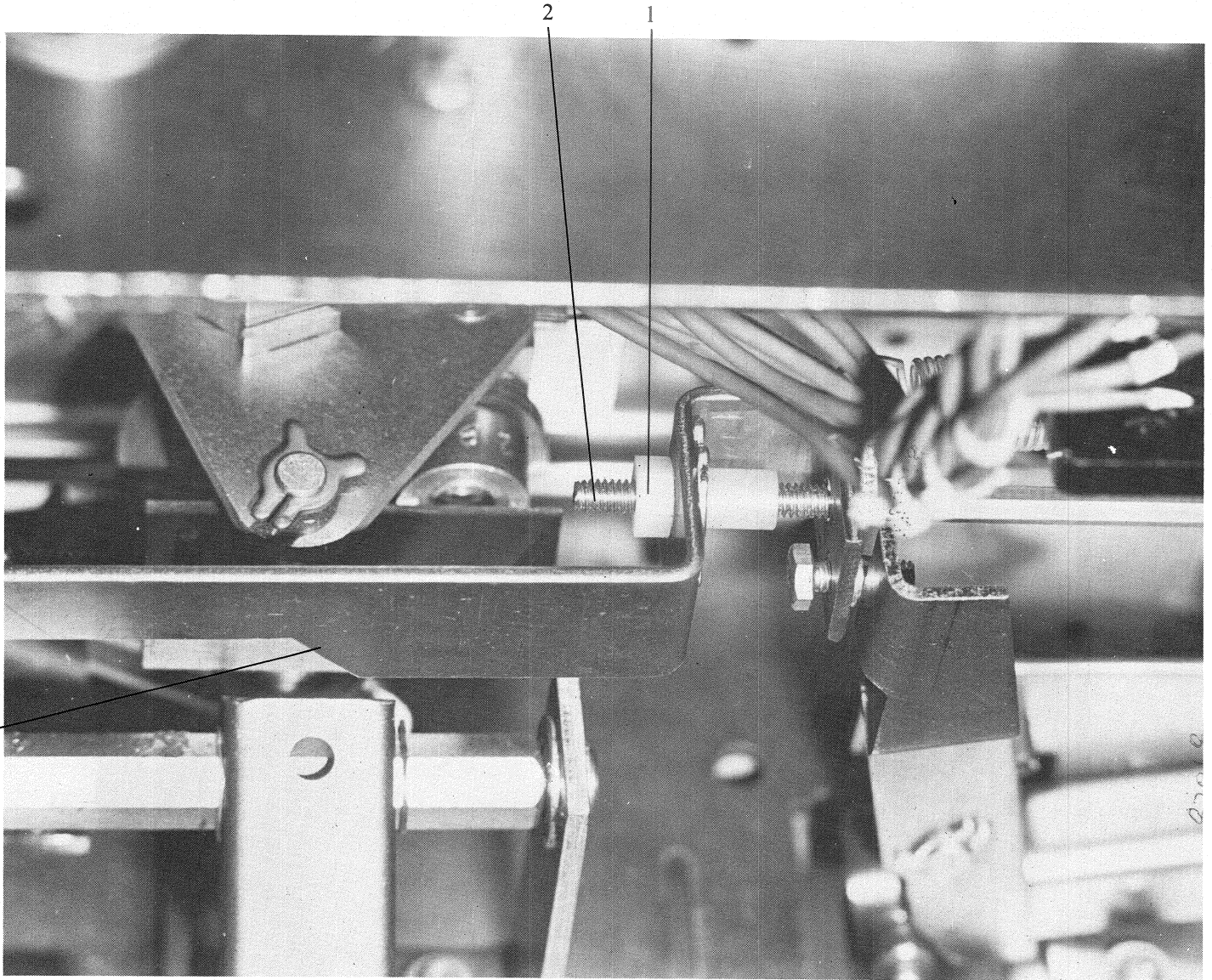

82018

FIG. 14 CLOSING COIL ADJUSTMENT

1. CLOSING COIL ADJUSTING NUT
2. CLOSING COIL ADJUSTING SCREW
3. LINK TO CLOSING LATCH

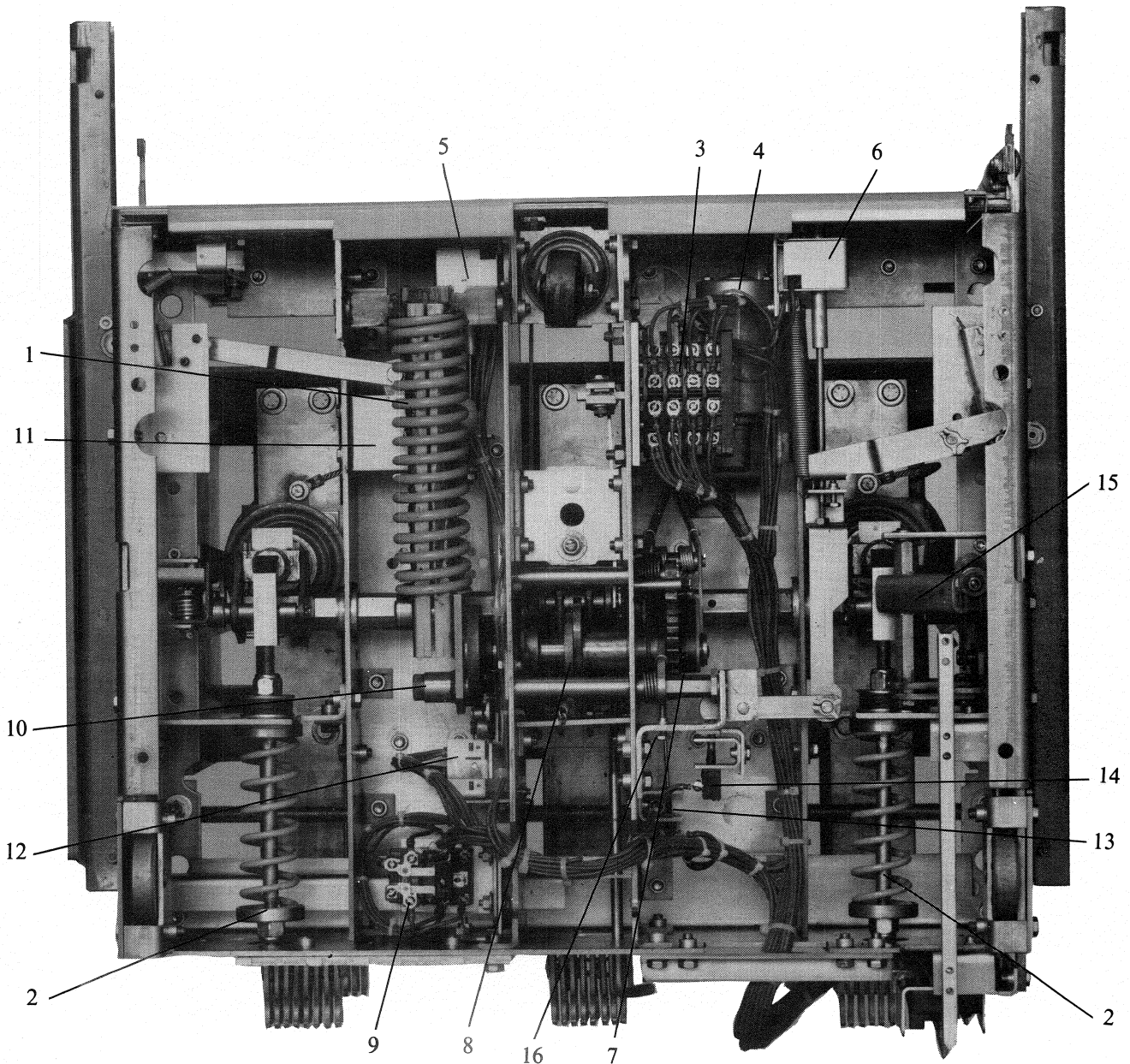

83004

FIG. 15 BOTTOM VIEW OF ML-18 SPRING CHARGED MECHANISM

- |                          |   |
|--------------------------|---|
| 1. CLOSING SPRING        | 9. 52Y RELAY                              |
| 2. OPENING SPRING        | 10. PIVOT BOLT                            |
| 3. AUXILIARY SWITCH      | 11. INTERLOCK BRACKET                     |
| 4. SPRING CHARGING MOTOR | 12. SM/LS MOTOR CONTROL SWITCH            |
| 5. TRIP COIL             | 13. L/C LATCH CHECKING SWITCH             |
| 6. CLOSING COIL          | 14. CL/MS CLOSING LATCH MONITORING SWITCH |
| 7. RATCHET WHEEL         | 15. STATIONARY AUXILIARY SWITCH OPERATOR  |
| 8. CLOSING CAM           | 16. CLOSE LATCH ADJUSTING SCREW           |



## ELECTRICAL CHECKS

### PRIMARY CONTACT EROSION INDICATION

In the closed position, the indicator disk (5), Figure 7, below the operating rod insulator is aligned with a reference arm (4) on new interrupters. With the breaker in the closed position, the indicator disk (5), Figure 7, will move upward from alignment with the reference point due to contact erosion. Contact erosion will decrease the wipe which may be brought back to normal by performing wipe adjustment. When erosion reaches 1/8 inch, the Power/Vac\* interrupters should be replaced. Do not readjust the alignment of the erosion indicator except when installing a new vacuum interrupter.

### CONTROL COIL PLUNGER TRAVEL

#### TRIP COIL

With the breaker in the open position and the closing spring in the charged position, make certain that the trip linkage and trip shaft move freely over the full plunger travel.

#### CLOSE COIL

With the closing spring discharged operate the plunger in the same manner as described above for the trip coil. Make certain that the plunger moves freely over its full stroke in the coil.

### CONTROL SWITCHES

There are three switch locations on the ML-18 mechanism. The CL/MS closing latch monitoring switch (14), Figure 15, is to the rear of the ratchet wheel and is operated from the closing latch linkage. The SM/LS spring motor limit switches (12), Figure 15, control the spring charging motor and the anti-pump relay. The 52 charge switch, which is in the same location, can be used for remote indication of the charged condition of the spring. L/C latch checking switch 13, Figure 15, monitors the position of the trip latch.

The switches are adjusted as described in Table 2 Item 8.

### CONTROL POWER

After the breaker has been operated several times with the manual charging lever and the mechanism adjustments are checked as described, the closed circuit operating voltages should be checked at the close coil, trip coil, and motor terminals. Control power for electrical operation of the breaker may be from either an alternating or direct current source. The operating ranges for the closing and tripping voltages as given on the breaker nameplate, are as follows:

Rated Nominal Voltage	Close or Motor Circuit		Trip Circuit	
	Min.	Max.	Min.	Max.
48 DC	38	56	28	56
125 DC	100	140	70	140
250 DC	200	280	140	280
120 AC	104	127	Not available in ML-18	
240 AC	208	254	Not available in ML-18	

If the closed circuit voltage at the terminals of the coil or motor does not fall in the specified range, check the voltage at the source of power and line drop between the power source and breaker.

When two or more breakers operating from the same control power source are required to close simultaneously, the closed circuit voltage at the closing coil or motor of each breaker must fall within the specified limits.

### TIMING

Timing may be checked by monitoring control circuit voltage and using no more than six volts DC and one ampere through the vacuum interrupter contact to indicate closed or open condition. Typical time ranges vary with coil voltage but nominal values are:

Initiation of trip signal to contact parting  
35-45 Milliseconds

Initiation of close signal to contact closing  
60-90 Milliseconds

Trip-free operation may be checked by applying a simultaneous close and trip signal and a minimum reclose operation may be checked by tripping a charged breaker open while maintaining a close signal.

Instantaneous reclose time\* 100-150 Milliseconds

\*Time from application of trip signal and close signal until breaker opens and recloses.

## MAINTENANCE

### GENERAL

Power/Vac\* circuit breakers have been designed to be as maintenance free as practicable. They include features such as sealed vacuum interrupters and long life synthetic greases which contribute to many years of trouble free performance with a minimum amount of maintenance attention.

### SERVICE CONDITIONS

The frequency of required maintenance depends on the severity of the service conditions of the switchgear application. If the service conditions are mild the interval between maintenance operations may be extended to 10 years or 10,000 no load or normal load switching operations.

Mild service conditions are defined as an environment in which the switchgear is protected from the deleterious effects of conditions such as:

Salt spray

Changes in temperature that produce condensation

Conductive and/or abrasive dust

Damaging chemicals and fumes

Vibration or mechanical shock

High relative humidity ( 90%)

Temperature extremes ( -30°C, 40°C)

**BEFORE ANY MAINTENANCE WORK IS PERFORMED, MAKE CERTAIN THAT ALL CONTROL CIRCUITS ARE DE-ENERGIZED AND THAT THE BREAKER IS REMOVED FROM THE METAL-CLAD UNIT. DO NOT WORK ON THE BREAKER OR MECHANISM WHILE IN THE CLOSED POSITION WITHOUT TAKING PRECAUTIONS TO PREVENT ACCIDENTAL TRIPPING. THIS CAN BE DONE BY REPLACING THE TRIP LATCH BLOCKING BOLT USED FOR SHIPPING TO BLOCK THE TRIP SHAFT AND SECURE THE INTERRUPTER CONTACTS IN THE CLOSED POSITION. DO NOT WORK ON THE BREAKER WHILE THE CLOSING SPRING IS CHARGED UNLESS IT IS SECURED IN THAT POSITION BY THE CLOSE-SPRING GAG.**

### FAULT INTERRUPTIONS

The erosion rate of the primary contacts in the vacuum interrupters is very low for no load and normal load switching operations. However, fault current interruptions at or near the breaker rating may result in appreciable contact erosion. With frequent fault interruptions it is necessary to perform maintenance based on the number of interruptions. After each 15 fault interruptions the following should be performed.

1. Contact erosion per page 27
2. Wipe and gap per Table 3 Item 6 & 7
3. Vacuum interrupter integrity test per page 27

### POWER/VAC\* INTERRUPTER

The Power/Vac\* interrupter used in this breaker is a reliable, clean interrupting element. Since the contacts are contained in a vacuum chamber, they remain clean and require no maintenance at any time. The metallic vapors eroded from the contact surfaces during high current

interruption remain in the chamber and are deposited on metal shields thus insuring a high dielectric value of the vacuum and the walls of the glass container.

### CONTACT EROSION

Check in the breaker-closed position per PRIMARY CONTACT EROSION INDICATION. When erosion reaches 1/8 inch, the interrupter should be replaced.

### TRANSFER FINGER WEAR

Examine the moving contact rod projecting below the transfer fingers with the breaker open, wiping off the lubricant in order to see the metal surface condition. The finger locations should present a burnished silver contact without copper appearance at more than one location. If copper is visible at more than one location per pole or the silver plating is torn, the interrupter assembly should be replaced.

### INSULATION TESTS

Since definite limits cannot be given for satisfactory insulation values, a record should be kept of the megohm-meter readings as well as temperature and humidity readings. This record should be used to detect any weakening of the insulation from one check period to the next.

The primary circuit insulation on the breaker may be checked phase to phase and phase to ground using a 2500V megohmmeter.

To measure the breaker secondary circuit insulation resistance, remove the motor leads, and thread a wire connecting all secondary disconnect pins together except pin #24 (ground pin). The measurement may be made by connecting a 500V megohmmeter from the wire to ground.

### HIGH-POTENTIAL TEST

If high potential tests to check the integrity of the insulation are required, the AC high potential test described is strongly recommended. DC high potential testing is not recommended except for the VACUUM INTERRUPTER INTEGRITY TEST. The following procedure must be adhered to.

**CAUTION: IF DC HIGH POTENTIAL TESTING IS REQUIRED, THE DC HIGH POTENTIAL MACHINE MUST NOT PRODUCE PEAK VOLTAGES EXCEEDING 50KV.**

- (1) Primary Circuit — The breaker should be hipotted in the closed breaker mode. An AC hipot machine capable of producing the test voltages shown below may be used to hipot the breaker phase to phase and phase to ground.

BREAKER VOLTAGE Rating	TEST VOLTAGE 60 HZ (RMS)
4.16 KV	14 KV
13.8 KV	27 KV

The machine should be connected with its output potential at zero and the voltage increased to the test voltage and that voltage maintained for 60 seconds. The voltage should then be returned to zero and the hipot machine removed from the circuit. NOTE — Do not exceed the test voltage indicated for the applicable breaker voltage rating.

- (2) Secondary Circuit — Prior to hipotting the breaker secondary circuit, remove the motor leads, thread a wire connecting all secondary disconnect pins together except pin #24 (ground pin). Connect the hipot machine from this wire to ground. Increase the voltage to 1125 volts (rms) 60 Hz and maintain for 60 seconds. Reduce the voltage to zero and remove the hipot machine from the circuit. Remove the wire connecting the secondary disconnect pins and reinstall the motor leads.

### VACUUM INTERRUPTER INTEGRITY TEST

CAUTION: X-RADIATION MAY BE PRODUCED IF AN ABNORMALLY HIGH VOLTAGE IS APPLIED ACROSS A PAIR OF ELECTRODES IN A VACUUM. X-RADIATION MAY INCREASE IN VOLTAGE AND/OR A DECREASE IN CONTACT SEPARATION.

DURING A HIGH POTENTIAL OR A VACUUM INTEGRITY TEST ANY X-RADIATION WHICH MAY BE PRODUCED WILL NOT BE HAZARDOUS AT A DISTANCE SAFE FOR HIGH POTENTIAL TESTING, IF THE TEST IS CONDUCTED AT THE RECOMMENDED VOLTAGE AND WITH THE NORMAL OPEN CIRCUIT BREAKER CONTACT SEPARATION.

DO NOT APPLY VOLTAGE THAT IS HIGHER THAN THE RECOMMENDED VALUE. DO NOT USE CONTACT SEPARATION THAT IS LESS THAN THE NORMAL OPEN POSITION SEPARATION OF THE BREAKER CONTACTS.

This test of the vacuum interrupter will determine its internal dielectric condition and vacuum integrity. With the breaker open individually check each interrupter by connecting the hipot machine "hot" lead to the upper stud and the ground lead to the lower stud. If the machine has a center point ground, the connections may be made either way. Apply 36kV (rms) 60 Hz or 50KV DC (except for P/V 42A interrupters apply 19kV (rms) 60 Hz or 27 KV DC) and hold a minimum of five (5) seconds. If no breakdown occurs the interrupter is in acceptable condition. If a breakdown occurs, the interrupter should be replaced.

No attempt should be made to try to compare the condition of one vacuum interrupter with another nor to correlate the condition of any interrupter to low values of DC leakage current. There is no significant correlation.

After the high potential voltage is removed, discharge any electrical charge that may be retained.

CAUTION: MANY DC HIGH POTENTIAL MACHINES ARE HALF WAVE RECTIFIERS. THIS TYPE OF HI-POT TESTER MUST NOT BE USED TO TEST VACUUM INTERRUPTERS. THE CAPACITANCE OF THE POWER/VAC\* BOTTLES IS VERY LOW AND THE LEAKAGE IN THE RECTIFIER AND ITS DC VOLTAGE MEASURING EQUIPMENT IS SUCH THAT THE PULSE FROM THE HALF WAVE RECTIFIER MAY BE IN THE NEIGHBORHOOD OF 120KV WHEN THE METER IS ACTUALLY READING 40KV. IN THIS CASE, SOME PERFECTLY GOOD BOTTLES CAN SHOW A RELATIVELY HIGH LEAKAGE CURRENT SINCE IT IS THE PEAK VOLTAGE OF 120KV THAT IS PRODUCING ERRONEOUS BOTTLE LEAKAGE CURRENT. IN ADDITION, ABNORMAL X-RADIATION MAY BE PRODUCED.

An acceptable high potential machine is available from the Medium Voltage Switchgear Business Section, Burlington, Iowa, Catalog Number 282A2610P001. The following machines are also acceptable.

Hipotronics	Model 860PL
Hipotronics	Model 880PL
Hipotronics	Model 7BT 60A
James G. Biddle	Catalog 222060

### PRIMARY CIRCUIT RESISTANCE

A resistance check of the primary circuit may be made with the breaker closed. Use a low resistance measuring instrument which measures microhms. The 100 ampere reading should not exceed 50 microhms when connected across the primary bars on the breaker side of the disconnect fingers.

### MECHANISM

Check all items on Table 2, Summary of Adjustments and Critical Dimensions, readjusting or tightening as required. Lubricate as recommended under LUBRICATION.

### PRIMARY INSULATION PARTS

Using dry non-linting cloth or industrial-type wipers, clean accessible insulation surfaces on the interrupter supports and operating rod insulators. In service locations where contamination is heavy or external flashovers have occurred during interrupter high-potential testing, remove the interrupter assembly per the procedure in REPAIR AND REPLACEMENT and clean the inside surface of the interrupter supports and the outer insulation surface of the Power/Vac\* interrupters. Be sure to discharge the interrupter midband ring before removing the interrupters. Removal and reassembly of interrupters will normally not require readjustment due to the design of the interrupter operating rod insulator connection. They should be returned to the same location from which they were removed.

## LUBRICATION

Proper lubrication is important for maintaining reliable circuit breaker performance. The ML-18 mechanism uses bearings which have a synthetic lining in some locations. These bearings do not require lubrication to maintain low friction, but lubrication does not harm them and oiling lightly is recommended. Sleeve bearings are used in some linkage locations and needle or roller bearings are used for low friction on trip shaft and close shaft.

Bearings are lubricated during factory assembly with grease and oil but, all lubricants have a tendency to deteriorate by oxidation or contamination with age. Providing a fresh lubricant supply at periodic intervals is essential to proper breaker operation, especially where frequent operation may have forced lubricant out of the bearing surfaces. Apply a few drops of light synthetic machine oil such as Mobile 1 at each bearing. Apply a coat of 0282A2048 P009 on the four corners of the closing spring guide where it enters inside the spring.

Electrical primary contact surfaces also require periodic lubrication to inhibit oxidation and minimize friction. At each inspection and maintenance interval, do the following:

- (1) Metal contact surfaces such as the movable contact rod of the interrupter should be lubricated with 0282A2048 P009. This grease is available packaged in a pint can to provide cleanliness and prevent oxidation.
- (2) Silvered primary contact surfaces. Wipe clean and apply a light coat of 0282A2048 P009 on primary disconnect fingers.
- (3) Pins of the secondary disconnect coupler should be lightly coated with 0282A2048 P009.

## REPAIR AND REPLACEMENT

### GENERAL

The following information covers in detail the proper method of removing various parts of the breaker in order to make any necessary repairs. This section includes only those repairs that can be made at the installation on parts of the breaker that are most subject to damage or wear.

**IMPORTANT: UPON COMPLETION OF ANY KIND OF REPAIR WORK, ALL INTERRUPTER AND MECHANISM ADJUSTMENTS MUST BE CHECKED.**

Refer to the sections on MECHANICAL AND ELECTRICAL ADJUSTMENTS.

### REPLACEMENT OF INTERRUPTER ASSEMBLIES

Interrupters are supplied as complete pole units which include the vacuum interrupter mounted in the interrupter support. The primary studs with disconnect fingers are part of the interrupter assemblies.

### CAUTION

**DO NOT ATTEMPT TO REMOVE OR REINSERT THE VACUUM INTERRUPTER IN THE INTERRUPTER SUPPORT ASSEMBLY. SPECIAL TOOLS AVAILABLE ONLY AT THE FACTORY ARE REQUIRED.**

## RECOMMENDED MAINTENANCE

The following operations should be performed at each maintenance.

1. Perform a visual inspection of the breaker. Check for loose or damaged parts.
2. Perform the slow closing operation described on page 12.
3. Check the erosion indicator and the wipe and gap as described on pages 14 and 25.
4. Perform the vacuum interrupter integrity test as described on page 27.
5. Lubricate the breaker operating mechanism as described on this page.
6. Check the electrical operation using the test cabinet (if available) or the test position in the metalclad switchgear.
7. Examine the movable contact rod of the vacuum interrupter. With the breaker open, wipe the lubricant off the rod and examine the silver surface. The rod should have a burnished appearance without copper appearing through the silver. If copper is visible at more than one location per pole, or if the silver plating is torn, the interrupter assembly should be replaced. Relubricate movable contact rod with 0282A2048 P009 grease.
8. If desired, perform the additional electrical tests (Megger, primary and secondary high potential, and primary circuit resistance). See page 26.

1. Close the breaker and remove the coupling clamp, (2) Fig. A2. Open the breaker and remove the four bolts holding the pole assembly to the mechanism and remove the old pole assembly.

2. Set the new pole assembly in place and install the four mounting bolts. Set the pole assembly so that the distance between the primary studs and the studs on the adjacent pole assembly are 10" apart.

3. Close the breaker using the Slow Closing Operation. Perform the closing operation slowly while guiding the tip of the operating rod into the base of the movable contact rod, (2) Fig. 8, on the vacuum interrupter. After the breaker is fully closed install the coupling clamp.

4. Check and adjust the erosion indicator (5) Fig. 7 (if new interrupter assembly is installed), and the Wipe and Gap as described in Table 3 Item 6.

5. Perform the Vacuum Interrupter Integrity test.

6. Check primary stud wipe. (Refer to GEK 39672, Instructions and Recommended Parts For Maintenance. See section on Breaker Installation and Removal)

## CAUTION

THE PRIMARY STUD WIPE CAN ONLY BE CHECKED WHEN THE SWITCHGEAR IS DEENERGIZED.

## PRIMARY DISCONNECT FINGERS

The primary disconnect finger assemblies can be removed by removing roll pins which hold them in place on the primary studs. Finger contact surfaces should be coated with 0282A-2048 P009 lubricant.

### MECHANISM

**Pin Retaining Rings** — These rings are widely used in the ML 18 mechanism to retain pins. They can be installed and removed with a pair of standard pliers. Reuse is not recommended after removal. To remove, slowly squeeze the removal ears while pulling. To install, position on the pin groove and squeeze the installation ears closed to no more than 1/16 inch gap between ears.

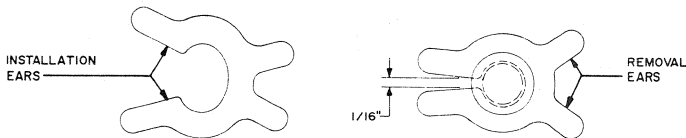

## CONTROL SWITCHES

Control switches may be removed from their mounting brackets by disconnecting the wires and removing the two mounting screws. Use a small screwdriver to remove and replace the switch on the bracket checking that the correct type, normally open or normally closed, is used. Reinstall wire and adjust per MECHANICAL ADJUSTMENTS — CONTROL SWITCHES.

## TRIP COIL REPLACEMENT

### TOOLS REQUIRED

- 5/16" Allen wrench
- Needle nose pliers
- 7/16" socket wrench
- 7/16" box/combination wrench
- 1/4" square drive ratchet
- 1/4" square 3" extension
- Loctite #271 or equivalent

Perform the operation in the following sequence:

1. Charge closing spring and install gag plate.
2. Depress the close and then the trip buttons.
3. Pump the manual close handle 3 - 4 times.
4. With the 5/16" Allen wrench remove the pivot bolt (10), Figure 15, on the closing spring (1).

5. Remove the closing spring.
6. Loosen the interlock bracket (11).
7. Remove the nuts from the coil bracket leaving the two bolts in place.
8. The trip coil can now be removed by cutting the coil leads.

To install the new coil connect leads with insulated butt connectors and reverse the above procedure. See Table 3 Item 1 for setting the stroke of the armature. Apply Loctite to the threads of the pivot bolt when it is replaced. Charge the breaker and electrically close and trip it to make certain it has been reassembled correctly.

## CLOSING COIL REPLACEMENT

Remove the closing coil housing (6), Figure 15. Disassemble the closing armature and closing coil adjustment screw (2), Figure 14. Cut the leads to the closing coil and remove the coil. Butt splice the new coil into the wiring harness and reassemble the coil and housing. Readjust the closing coil armature travel in accordance with instructions in Table 3 Item 2.

## RENEWAL PARTS

It is recommended that sufficient renewal parts be carried in stock to enable the prompt replacement of any worn, broken, or damaged parts. A stock of such parts minimizes service interruptions caused by breakdowns, and saves time and expense. When continuous operation is a primary consideration, more renewal parts should be carried, the amount depending upon the severity of the service and the time required to secure replacements.

Renewal parts which are furnished may not be identical to the original parts, since improvements are made from time to time. The parts which are furnished, however, will be interchangeable.

The renewal parts list covers all breakers on the cover.

## ORDERING INSTRUCTIONS

1. Always specify the complete nameplate data of both the breaker and the mechanism.
2. Specify the quantity, catalog number (if listed), reference number (if listed), and description of each part ordered, and this bulletin number.
3. Standard hardware, such as screws, bolts, nuts, washers, etc. is not listed in this bulletin. Such items should be purchased locally.
4. For prices or information on parts not listed in the Renewal Parts List, refer to the nearest office of the General Electric Company.

RECOMMENDED SPARE PARTS FOR POWER/VAC BREAKERS WITH ML-18 MECHANISM

NO. REQ'D PER BRKR.	MODEL	DESCRIPTION	CATALOG NO.
1	0	Charging Motor 48V-DC 125V-DC and 120V-AC 250V-DC and 240V-AC	0177C5050G003 0177C5050G001 0177C5050G002
1	0	Relay (Non-Nuclear)  48V-DC 125V-DC 250V-DC 120V-60 Hz 240V-60 Hz 120V-50 Hz 240V-50 Hz	0282A2008P001 0282A2008P002 0282A2008G001 0282A2008P003 0282A2008P004 0282A2008P005 0282A2008P006
1	0	Potential Trip Coil (5 Cycle)  48V-DC 125V-DC 250V-DC	0282A7015G004 0282A7015G006 0282A7015G007
1	0	Closing Coil (Standard)  48V-DC 125V-DC 250V-DC 120V-AC 240V-AC	0282A7015G001 0282A7015G002 0282A7015G003 0282A7015G004 0282A7015G005
2	0	Control Switch, Normally Open	0282A7094P001
2	0	Control Switch, Normally Closed	0282A7094P002
1	0	Auxiliary Switch	0209B8064P001

RECOMMENDED SPARE PARTS FOR POWER/VAC BREAKERS WITH ML-18 MECHANISM

**INTERRUPTER ASSEMBLY  
(POLE UNIT COMPLETE)**

BREAKER TYPE	MODEL	CONTINUOUS CURRENT AMPERES	C & L CURRENT RATING, KA	TYPE APPLICATION	QTY.	CATALOG NUMBER
VB 4.16-250	0	1200	58	STANDARD & SEISMIC	3	0282A2751G077 0282A2751G079 0282A2751G081
	0	2000	58		3	
	0	1200/2000	58		3	
VB 13.8-500	0	1200	37	STANDARD & SEISMIC	3	0282A2751G052 0282A2751G054 0282A2751G068
	0	2000	37		3	
	0	1200/2000	37		3	
VB1 13.8-500	0	1200	58	STANDARD & SEISMIC	3	0282A2751G089 0282A2751G090 0282A2751G091
	0	2000	58		3	
	0	1200/2000	58		3	

RECOMMENDED SPARE PARTS FOR POWER/VAC BREAKERS WITH ML-18 MECHANISM

DESCRIPTION	MODEL	QUANTITY PER BREAKER						CATALOG NO.
		1200		2000		1200/ 2000		
		37	58	37	58	37	58	
PRIMARY DISCONNECT CONTACT ASSEMBLY	0	6						0282A2725G002
	0		6					0282A2701G002
	0			6	6			0282A2700G004
	0					6	6	0282A2834G002
OPERATING ROD	0	3	3	3	3	3	3	0177C5014G001

GENERAL ELECTRIC COMPANY  
MEDIUM VOLTAGE SWITCHGEAR BUSINESS SECTION  
BURLINGTON, IOWA 52601

**GENERAL**  **ELECTRIC**