



**INSTRUCTIONS**

**GEK 7153G**  
SUPERSEDES GEK-7153F

---

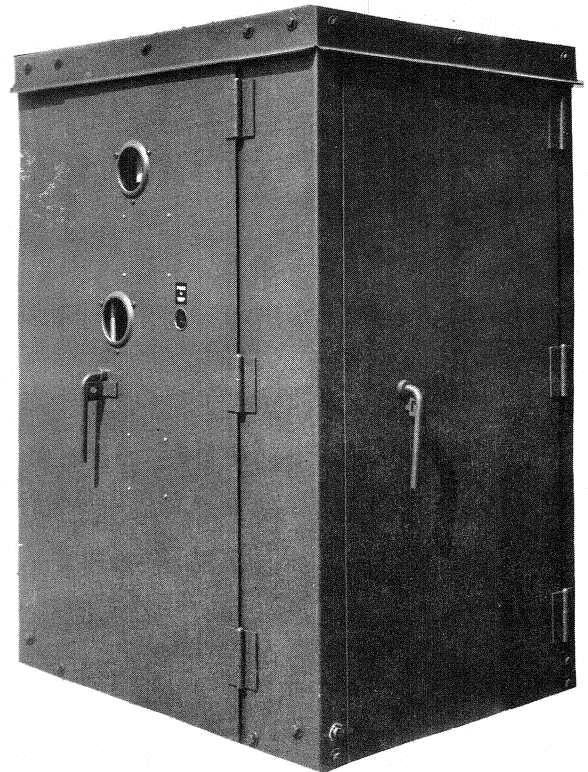
---

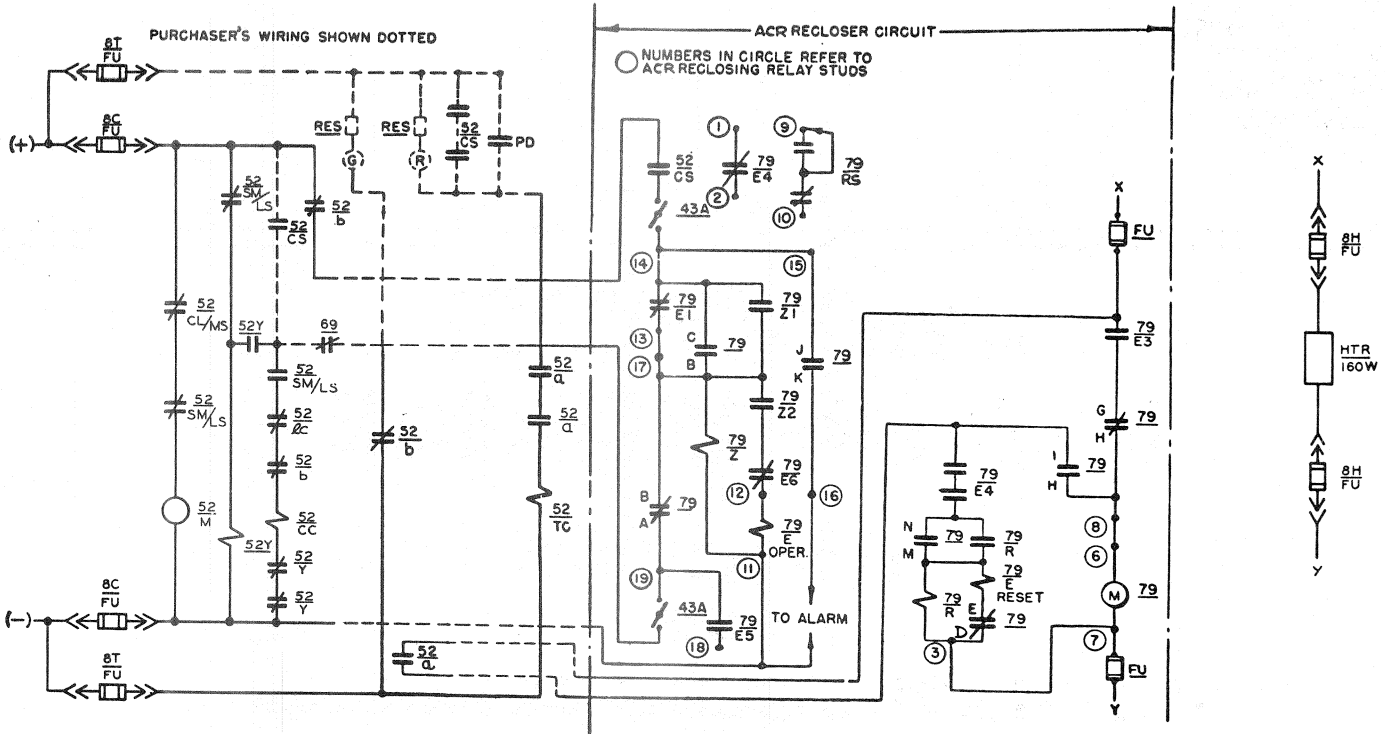
**SPRING-CHARGED  
OPERATING MECHANISM**

**TYPE ML-14-0  
FOR  
OIL-BLAST CIRCUIT BREAKERS**

**CONTENTS**

Introduction . . . . .	3
Receiving, Handling and Storage. . . . .	3
Description . . . . .	3
Installation . . . . .	5
Operation . . . . .	22
Maintenance . . . . .	25
Replacement Parts . . . . .	33





- |       |   |     |  |
|-------|---|-----|--|
| 8C    | Close Control Power-Fused Disconnect Switch                 | 69  | Permissive Control Switch<br>Opened by manual tripping device on the mechanism-<br>Hand Reset to Close |
| 8H    | Heater Power-Fused Disconnect Switch                        | 79  | ACB Recloser   |
| 8T    | Trip Control Power-Fused Disconnect Switch                  | E   | Interlocking Relay and Contacts for 79   |
| 43A   | Recloser Cut-out Switch                                     | M   | Recloser Timing Motor  |
| 52    | Oil Circuit Breaker   | R   | Clutch Release Unit and Contacts for 79  |
| a     | Normally Open Auxiliary Switch-<br>Open when 52 is open     | Z   | Anti-pump Unit and Contacts for 79   |
| b     | Normally Closed Auxiliary Switch-<br>Closed when 52 is open | FU  | Fuse   |
| CC    | Closing Coil  | G   | Green Indicating Lamp  |
| CS    | Control Switch  | HTR | Heater   |
| CL/MS | Closing Latch Monitoring Switch                             | RES | Resistor   |
| lc    | Trip Latch Checking Switch                                  | R   | Red Indicating Lamp  |
| M     | Spring-charging Motor                                       | PD  | Protective Device  |
| SM/LS | Limit Switch for Spring-charging Motor                      |     |  |
| TC    | Trip Coil   |     |  |
| Y     | Anti-pump Auxiliary Relay                                   |     |  |

Fig. 1 Typical Connection Diagram  
Breaker Position - Open  
Closing Springs - Discharged

(For actual wiring see connection diagram furnished with equipment)

Cover (8037808)

Fig. 1 (0124C3224 Rev. 1)

# SPRING-CHARGED OPERATING MECHANISM TYPE ML-14-0

## INTRODUCTION

The Type ML-14-0 operator is a spring operated mechanism for outdoor oil-blast circuit breakers. It is designed for high speed operation during the circuit breaker interruption of faults and high speed reclosing. It is mechanically trip-free and non-pumping when closed on short circuits. Its high speed characteristic is the result of a simple, ingenious, rugged linkage design having low-friction bearings.

The mechanism and associated

operating equipment are enclosed in a weatherproof housing designed for mounting on the front end of the breaker. D-c voltage is required for the control circuit. A-c voltage is recommended for the spring-charging motor and required for the heater circuits. Since the control circuit requires very low operating currents, the necessity for large storage batteries or rectifiers is eliminated. Batteries are recommended for the d-c source. The mechanism and its accessories will operate at the standard ANSI voltage ratings. The breaker nameplate is mounted on the inside of the front door of the mechanism housing.

PROPER INSTALLATION AND MAINTENANCE ARE NECESSARY FOR CONTINUED SATISFACTORY OPERATION. The following instructions will provide information for placing the mechanism and breaker in service and for the necessary maintenance. It should be kept in mind that the illustrations in the instruction book are for illustrative purposes and may not always be an actual picture of the equipment being furnished. For final information always refer to the drawings that are furnished separately with the equipment. For additional instructions on the circuit breaker, refer to the breaker instruction book.

## RECEIVING, HANDLING AND STORAGE

Each mechanism is carefully inspected and packed by workmen experienced in the proper handling and packing of electrical equipment. Immediately upon receipt of a mechanism, an examination should be made for any damage sustained during shipment. If injury or rough handling is evident, a damage claim should be filed with the transportation company, and the nearest General Electric Apparatus Sales Office should be promptly notified.

The crating or boxing must be

removed carefully using a nail puller. Check all parts against the packing list to make certain that no parts have been overlooked while unpacking. Always search the packing material for hardware that may have loosened in transit.

If the mechanism cannot be installed in the proper location immediately, and it is necessary to store the equipment, it should be kept in a clean, dry place protected from mechanical injury. Machined parts should be coated heavily with grease

to prevent rusting. If stored for any length of time, periodic inspections should be made to see that corrosion has not taken place and to insure good mechanical condition. If possible, the space heater should be energized to prevent moisture condensation inside the mechanism housing.

Should the mechanism be stored under unfavorable atmospheric conditions, steps should be taken to dry out the mechanism before it is placed in service

## DESCRIPTION

The ML-14 spring-charged operator consists of motor operated closing springs with the associated mechanism and control equipment. The unit is designed to operate large outdoor oil circuit breakers with provision for closing, opening,

trip-free and reclosing operations.

The control house for this mechanism is a steel weatherproof house which contains a felt strip as a sealant around the doors. Inside this housing are

located a motor for charging the closing springs, closing spring's operating mechanism, auxiliary switch and the control panel with its relaying, operating and control switches and BCT terminal boards.

*These instructions do not purport to cover all details or variations in equipment nor to provide for every possible contingency to be met in connection with installation, operation or maintenance. Should further information be desired or should particular problems arise which are not covered sufficiently for the purchaser's purposes, the matter should be referred to the General Electric Company.*

*To the extent required the products described herein meet applicable ANSI, IEEE and NEMA standards; but no such assurance is given with respect to local codes and ordinances because they vary greatly.*

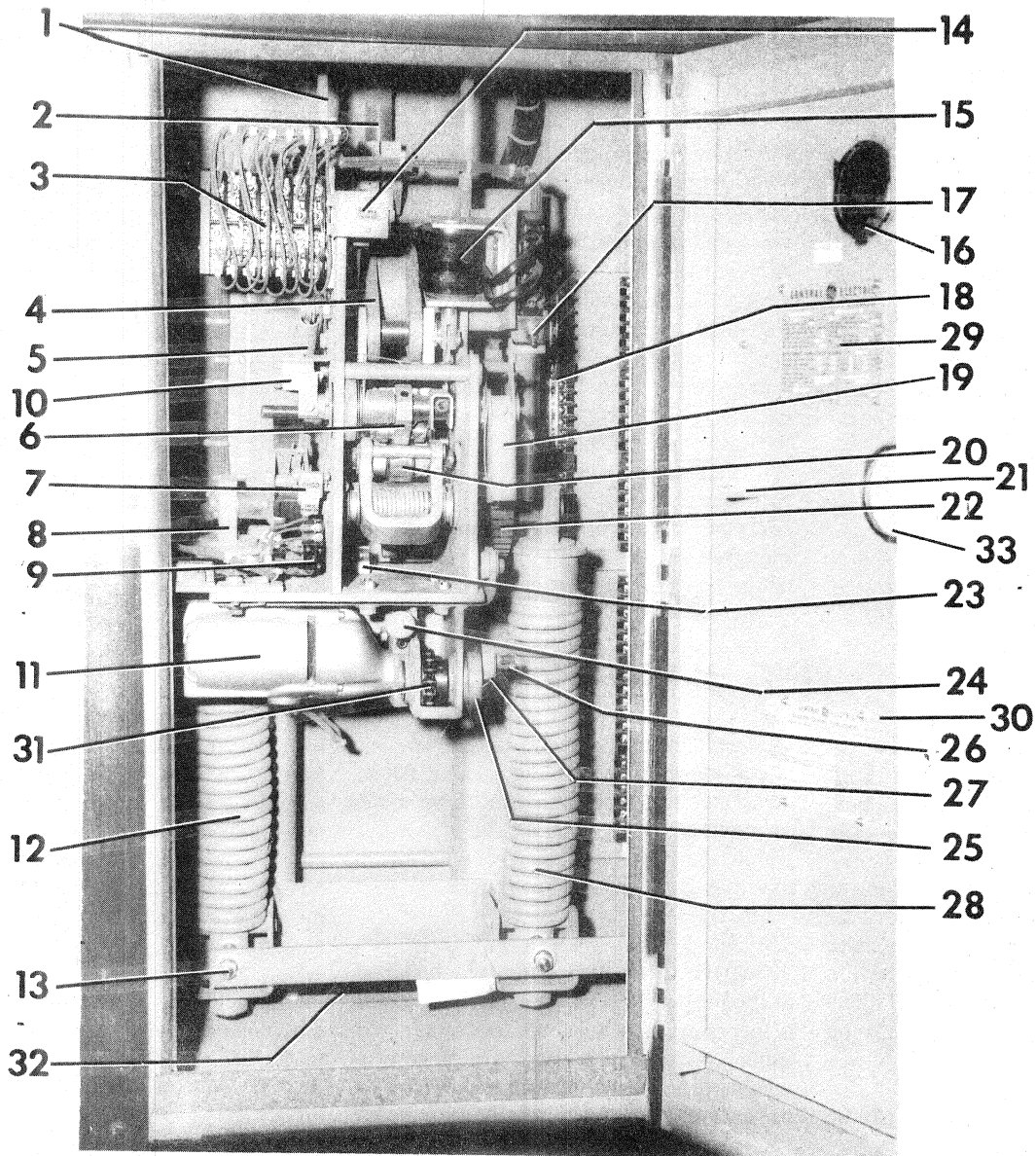


Fig. 2 (8042489)

- |                                   |   |   |
|-----------------------------------|---|---|
| 1. House Support Bracket          | 13. Closing Spring Blocking Device              | 23. Closing Latch Monitoring Switch Operating Lever |
| 2. Breaker Vertical Operating Rod | 14. Operation Counter                           | 24. Manual Close Push Rod Button                    |
| 3. Auxiliary Switch               | 15. Trip Coil (52TC)                            | 25. Eccentric                                       |
| 4. Output Crank                   | 16. Operation Counter Window                    | 26. Manual Charging Stud (5/8 inch hex)             |
| 5. Prop Reser Spring              | 17. Lock-out Switch (69 Device)                 | 27. Driving Link                                    |
| 6. Trip Latch                     | 18. Bushing Current Transformer Terminal Boards | 28. Right Closing Spring                            |
| 7. Charge-discharge Indicator     | 19. Manual Trip Lever                           | 29. Breaker Nameplate                               |
| 8. Guide Block                    | 20. Trip Latch Roller                           | 30. Current Transformer Nameplate                   |
| 9. Motor Limit Switches           | 21. Manual Trip Push Button                     | 31. Driving Chain                                   |
| 10. Latch Checking Switch         | 22. Ratchet Wheel                               | 32. Heater  |
| 11. Spring-charging Motor         |   | 33. Charge-discharge Indicator Window               |
| 12. Left Closing Spring           |   |   |

Fig. 2 Front View of Mechanism

**NOTE:** Remove the wax paper strips which are between the door jam and the doors of the control house before energizing the heater. These strips are for paint protection during shipment and will not make a good weather seal if left in place.

Control voltages are given on the nameplate. The motor operating voltage

is either a-c or d-c, but preferably a-c.

Also provided on the equipment is a manual trip device. This consists of a mechanism for manually tripping the breaker and a lock-out switch for opening the closing circuit, to prevent the breaker from closing from a remote source when it is tripped by this mechanism locally.

**NOTE:** This mechanism is designed for electrical closing

when in use. **NEVER ATTEMPT SLOW MANUAL CLOSING WITH THE BLOCKING DEVICE IN PLACE AND THE BREAKER IN SERVICE. OPERATE SLOWLY AND MANUALLY ONLY WHEN THE BREAKER HAS BEEN COMPLETELY DEENERGIZED AND ISOLATED.**

## INSTALLATION

During the installation of the mechanism, it is necessary to make reference to the instruction book for the oil circuit breaker that it operates.

The mechanism and housing are normally shipped fastened directly to the frame of the oil circuit breaker. The mechanism is installed and properly adjusted when received. The trip latches are fastened during shipment and this fastening should be removed after the breaker has been moved into position.

### MOUNTING

If the mechanism and housing are shipped separately, or the mechanism and housing have been removed from the breaker for shipment, then it is necessary to fasten the mechanism and housing in position.

The breaker frame to which the operating mechanism is to be mounted should first be plumb. This procedure is described in the breaker instruction book. By placing a plumbed straight edge extending from top to bottom against the mechanism mounting pads on the breaker framework, determine the amount of shim washers needed to make them all flush. To this amount add an equal number of shims to each of the pads so that there is a nominal one-quarter inch thickness of shims. A single brass washer is to be placed between the steel washers and the mechanism housing and against the gasket for more effective sealing against the entrance of water. It may be necessary to add or remove steel shims to

obtain the correct alignment of the vertical rod and its cover pipe.

Raise the mechanism with a crane and align the mounting stud holes in the mechanism housing to those on the breaker framework and insert the studs. Tighten all nuts securely and lock with set screws.

Install the vertical operating rod cover pipe between the front crank cover support and the top of the mechanism housing. Sometimes it is convenient to install this cover pipe prior to raising the housing into position on the breaker tank. Next install the vertical operating rod. The length of the operating rod can be adjusted by means of right- and left-hand threaded couplings on the ends to obtain the required breaker adjustment as described in the breaker instruction book.

### CONNECTIONS

After the mechanism has been mounted, electrical connections can be made. Before making these, precautions should be taken to see that all leads to be connected to the mechanism are de-energized.

Run control wires in conduit insofar as it is practicable. Control wires must be run separately and remote from high tension leads and not in the same duct or parallel to high tension leads unless the distance separating the two sets of wiring is sufficient to prevent possible communication between them as a result of short circuits.

Use control wiring of adequate size so that with full operating current flowing to the operating mechanism, the voltage across the terminals of the mechanism will be within the limits specified as standard for the range of control voltage.

Use the proper connection diagram for each individual job for testing and making connections. The mechanism is wired completely at the factory to terminal boards mounted on the bottom of the control panel. Incoming conduits can be terminated in a removable plate in the housing floor directly under the terminal boards. This plate can be drilled to suit any conduit requirements. It is recommended that all conduits entering the mechanism housing be sealed off at their entrances to the housing.

### ADJUSTMENTS

Although the mechanism has been adjusted and tested at the factory, it is advisable to check all the following points as well as those listed under **FINAL INSPECTION** to be sure that no change has occurred during shipment and installation. No adjustments should be altered unless this inspection indicates it is necessary.

Use manual operation for all preliminary inspection. After the mechanism is connected to the breaker, operate it slowly to see that the operation is smooth throughout the closing stroke, that no binding occurs, and that no excessive play

is noticeable between parts. Electrical operation should be attempted only after it is certain that all mechanism adjustments are made correctly and that the oil circuit breaker is correctly adjusted according to its instructions.

The breaker and mechanism adjustments must be checked when the mechanism is being manually closed since the mechanism can only be operated slowly in the closing direction.

**UNDER NO CIRCUMSTANCES SHOULD THE BREAKER BE TRIPPED MANUALLY OR ELECTRICALLY WITHOUT OIL IN THE TANKS UNTIL THE PROPER BREAKER INSTRUCTION BOOK HAS BEEN CHECKED TO DETERMINE WHETHER OR NOT THE BREAKER CAN BE OPERATED WITHOUT OIL IN THE TANKS.**

Manual operation of the mechanism should not be attempted until the bearing surfaces of the mechanism have been checked for lubrication. Refer to the section on lubrication for the proper oils and greases.

#### MANUAL OPENING

The breaker can be tripped manually by operating the manual trip level (4), Fig. 3. This will give an opening operation very similar to that obtained when the breaker is tripped electrically. The breaker cannot be opened slowly, except with an optional maintenance jacking device.

#### MANUAL CLOSING

**DISCONNECT THE POWER TO THE SPRING-CHARGING MOTOR TO PREVENT ITS OPERATION BEFORE OPERATING THE BREAKER MANUALLY AND ALSO BEFORE MANUALLY CHARGING THE CLOSING SPRINGS.**

To operate the mechanism manually charge the breaker closing springs (12) and (28), Fig. 2, manually using a 5/8 inch ratchet wrench on the manual charging stud (26), Fig. 2, to turn the driving eccentric (25), Fig. 2. Turning the driving eccentric counterclockwise (pushing downward on the ratchet wrench), will advance the ratchet wheel (22) and compress the closing springs.

When the springs have reached the fully charged position the indicator (7), Fig. 2, will read "CHARGED", and the driving pawl (4), Fig. 5, will be raised from the ratchet wheel teeth. Additional turning of the eccentric will not advance the ratchet wheel. The latching and safety pawls (16), Fig. 3, work in conjunction with the driving pawl (4), Fig. 5, to prevent the ratchet wheel (73), Fig. 10, from turning backwards due to the force of the closing springs as the ratchet wrench (7), Fig. 5, is operated.

Insert the spring blocking device bar (13), Fig. 2, into both springs and manually discharge the springs against the pins by pushing the manual close button (24), Fig. 2. The springs are now blocked and slow closing of the breaker contacts can be accomplished by again turning the driving eccentric with a 5/8 ratchet wrench.

The spring blocking device is made to extend out the right door and must be removed in order to close the door. This is to prevent leaving the mechanism blocked accidentally after maintenance. Each mechanism is furnished with a blocking device and should remain in the bottom of the house since the spring centers may differ from unit to unit.

During the slow closing operation check to insure that the mechanism does not stick or bind during the entire stroke, that it latches securely in the closed position, and that it trips freely when the manual trip lever (19), Fig. 2, is operated. The breaker should not be operated electrically until it has been operated several times manually to insure freedom of action. At this time, also check the breaker adjustments as given in the breaker instruction book.

**DO NOT WORK ON EITHER THE BREAKER OR MECHANISM UNLESS THE CLOSING SPRINGS AND TRIP-LATCH ARE BLOCKED. THIS PRECAUTION IS REQUIRED TO PREVENT ACCIDENTAL CLOSING OR TRIPPING. USE THE 69 LOCK-OUT SWITCH IF REMOTE CONTROL IS USED.**

After the adjustments have been checked, the springs can be unblocked. Rotate the driving eccentric (25), Fig. 2, until the indicator (7), Fig. 2, reads "CHARGED" and the ratchet wheel (22),

Fig. 2, no longer is advanced. The closing spring blocking device (13), Fig. 2, can now be removed. **DO NOT OPERATE OR PUSH THE MANUAL CLOSE BUTTON (24), FIG. 2, WHILE THE BREAKER IS IN THE CLOSED POSITION.** Damage to the linkage, ratchet wheel and pawls might occur. This damage would be caused by the energy of the springs not being absorbed by the mechanism linkage and breaker in the spring hitting a stationary linkage instead of pushing a movable linkage.

Operate the circuit breaker electrically several times. Check the control voltage as described under CONTROL POWER CHECK.

**NOTE:** If the breaker secondary wiring is to be given a hi-potential test at 1500 volts a-c, remove both the major leads from the terminal connection. Failure to disconnect the motor from the circuit may cause damage to the winding insulation.

#### TRIP LATCH WIPE

Refer to Fig. 10 and to "U", Fig. 13. The wipe of the trip latch (50), Fig. 10, on the trip latch roller (52) should be from 3/16 inch to 1/4 inch. This can be measured by putting a film of grease on the latch (50), closing the breaker part way, and tripping. The mechanism has the proper trip latch wipe when the latch rests against the stop pin (53). No adjustment is provided and a visual inspection is usually all that is required. If this setting is not correct, look for insufficient travel of the trip shaft (24).

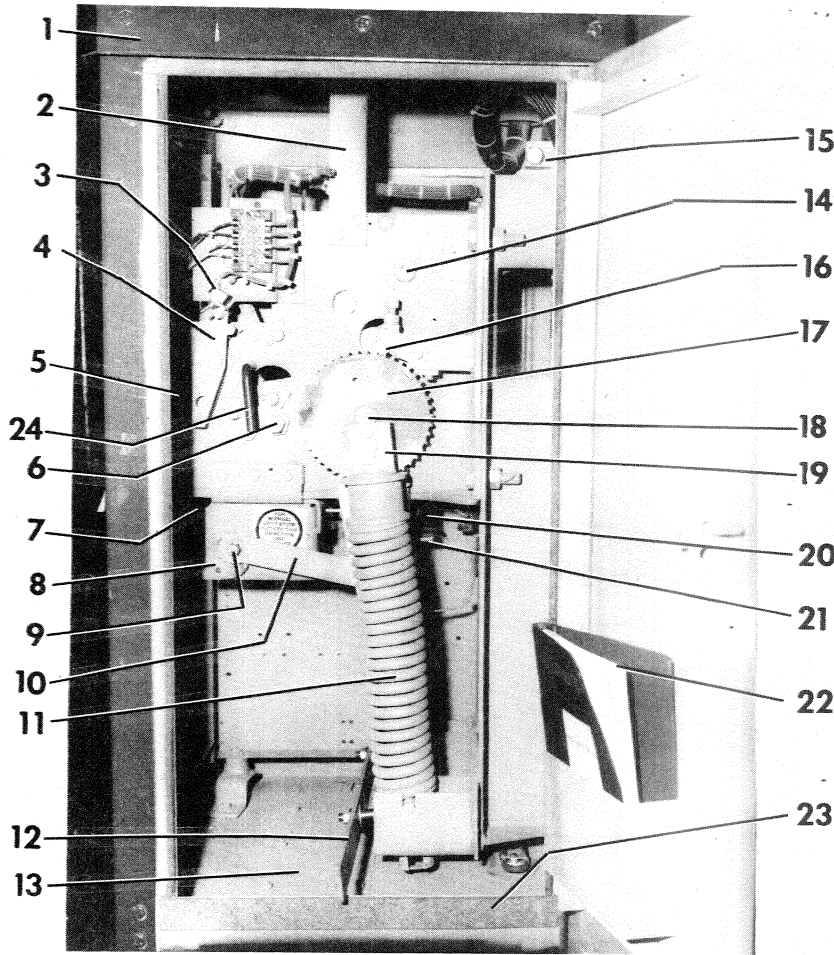
**WHEN WORKING ON THE MECHANISM IN THE CLOSED POSITION, KEEP FINGERS CLEAR OF THE LINKAGE, AS ACCIDENTAL TRIPPING CAN CAUSE SEVERE INJURY.**

Use the trip latch blocking pin tool which is inserted in the trip latch blocking pin hole (100), Fig. 9 and Fig. 12 and (24), Fig. 3, until it extends beyond the opposite frame.

#### TRIP LATCH CLEARANCE

Refer to Fig. 12, and to "R", Fig. 13, and "N", Fig. 14. With the breaker in

Fig. 3 (8042491)



will lock the eccentric. Tighten the lock-nuts on the eccentric after adjusting the eccentric.

#### PROP CLEARANCE

Refer to (38), Fig. 10, and to "V" Fig. 13. With the breaker closed as far as possible, that is, with the springs (79), and (62), Fig. 11, blocked and the cam (39), Fig. 10, rotated so that the cam follower roller shaft (68) is at its maximum height over the prop (38), the clearance between the prop and cam shaft should be 1/16 inch to 5/32 inch. No adjustment is provided and a visual inspection is usually all that is required.

#### PROP WIPE

Refer to Fig. 10 and "K", Fig. 13. With the breaker closed and the linkage resting on the closing prop (38), Fig. 10, the prop wipe should be 3/16 inch to 3/8 inch from the cam follower roller shaft (68), Fig. 10, to the edge of the prop. No adjustment is provided and a visual inspection is usually all that is required.

#### CLOSING LATCH WIPE

Refer to Fig. 9 and to "X" Fig. 15. The wipe between the closing latch (8) and the closing latch roller (29) should be 3/16 inch to 1/4 inch. If resetting is required, loosen, set, and retighten the adjustment screw (10), then tighten the locking nut (11).

#### CLOSING LATCH MONITORING SWITCH

Refer to Fig. 9 and to "T", Fig. 13. The closing latch (8) must be fully reset and the closing latch monitoring switch (16) operated before the motor (34) will start. The closing latch monitoring switch should be wiped by the operating lever (23), Fig. 2, so that the clearance between the operating lever and the switch mounting bracket (8), Fig. 6, is 0.005 to 0.032 inch. To obtain this adjustment bend the monitoring switch operating lever as necessary. Be sure the latch is fully reset before making any adjustments.

#### MOTOR LIMIT SWITCHES

Refer to Fig. 9 and to "Z", Fig. 15. With the closing springs blocked rotate

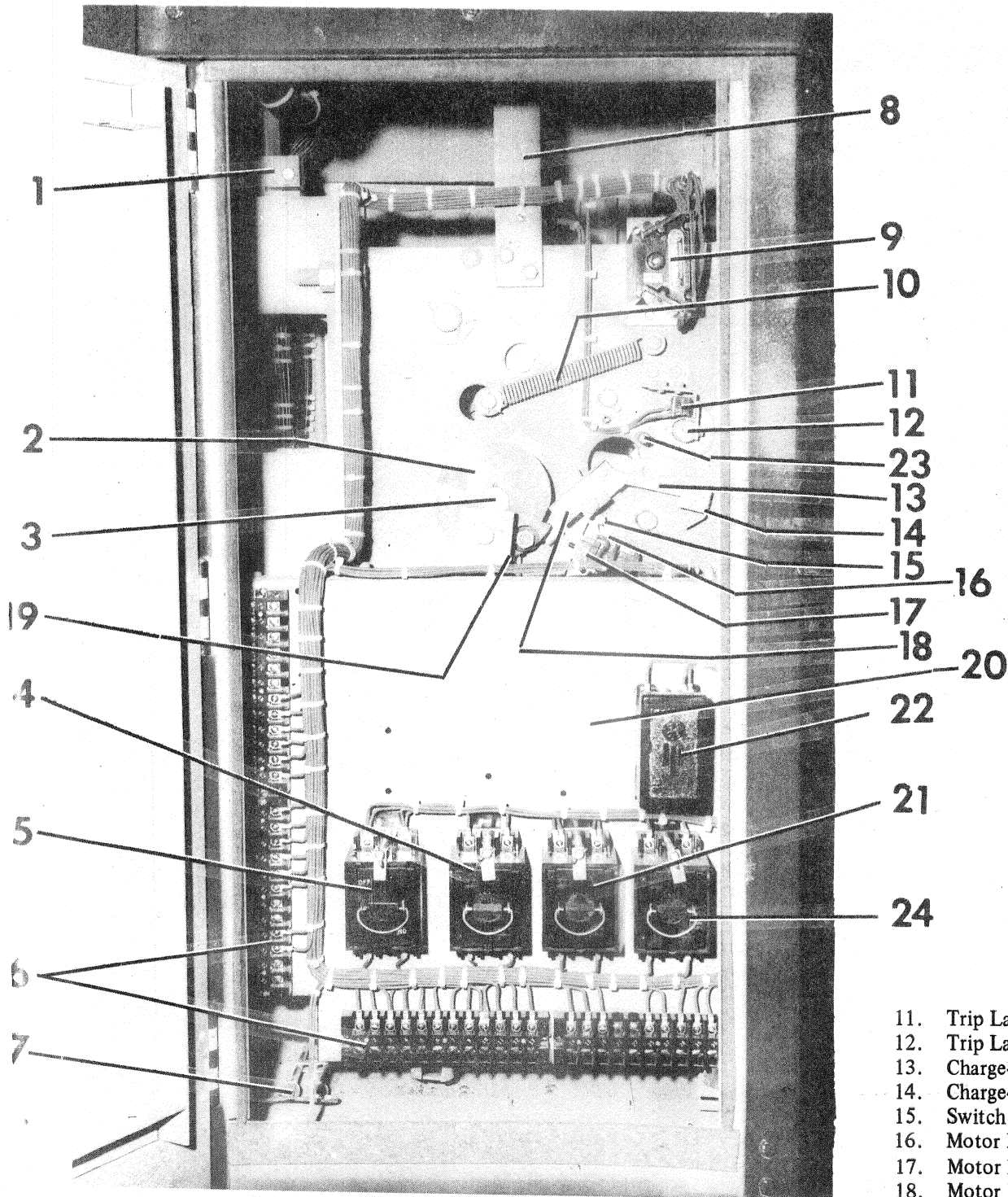
- |  |                                      |
|--|--------------------------------------|
| 1. Mechanism House                           | 12. Closing Spring Blocking Device   |
| 2. House Support Bracket                     | 13. Access Plate (Customer's Wiring) |
| 3. Lock-out Device (69 Switch)               | 14. Output Crank Main Shaft          |
| 4. Manual Trip Lever                         | 15. Output Coupling                  |
| 5. Manual Trip Push Rod                      | 16. Latching And Safety Pawls        |
| 6. Trip Latch Clearance Adjustment Eccentric | 17. Ratchet Wheel                    |
| 7. Manual Close Push Rod                     | 18. Cam Shaft                        |
| 8. Eccentric                                 | 19. Guide Block                      |
| 9. Manual Charging Stud (5/8 inch hex)       | 20. Closing Coil (52CC)              |
| 10. Driving Link                             | 21. Closing Coil Plunger             |
| 11. Right Closing Spring                     | 22. Instruction Book                 |
|  | 23. Weatherstrip                     |
|  | 24. Trip Latch Blocking Pin          |

Fig. 3 Right Side View of Mechanism

the tripped position and the closing springs (12) and (28), Fig. 2, charged, check the clearance between the trip latch (50), Fig. 11, and the trip latch roller (52). It should measure 1/32 inch to 3/32 inch.

To change the adjustment loosen the

locknut (84), Fig. 12, at the trip latch clearance adjustment eccentric (6), Fig. 3, with the breaker in the tripped position. Adjust the eccentric (25), Fig. 2, as necessary. Adjust the trip latch clearance by turning the eccentric in a clockwise direction while decreasing the clearance. This



- 1. Output Coupling
- 2. Limit Switch Cam
- 3. Cam Shaft
- 4. Closing Circuit Fused Pullout
- 5. Trip Circuit Fused Pullout

- 6. Terminal Boards
- 7. Control House Heater
- 8. House Support Bracket
- 9. Auxiliary Switch
- 10. Prop Reset Spring

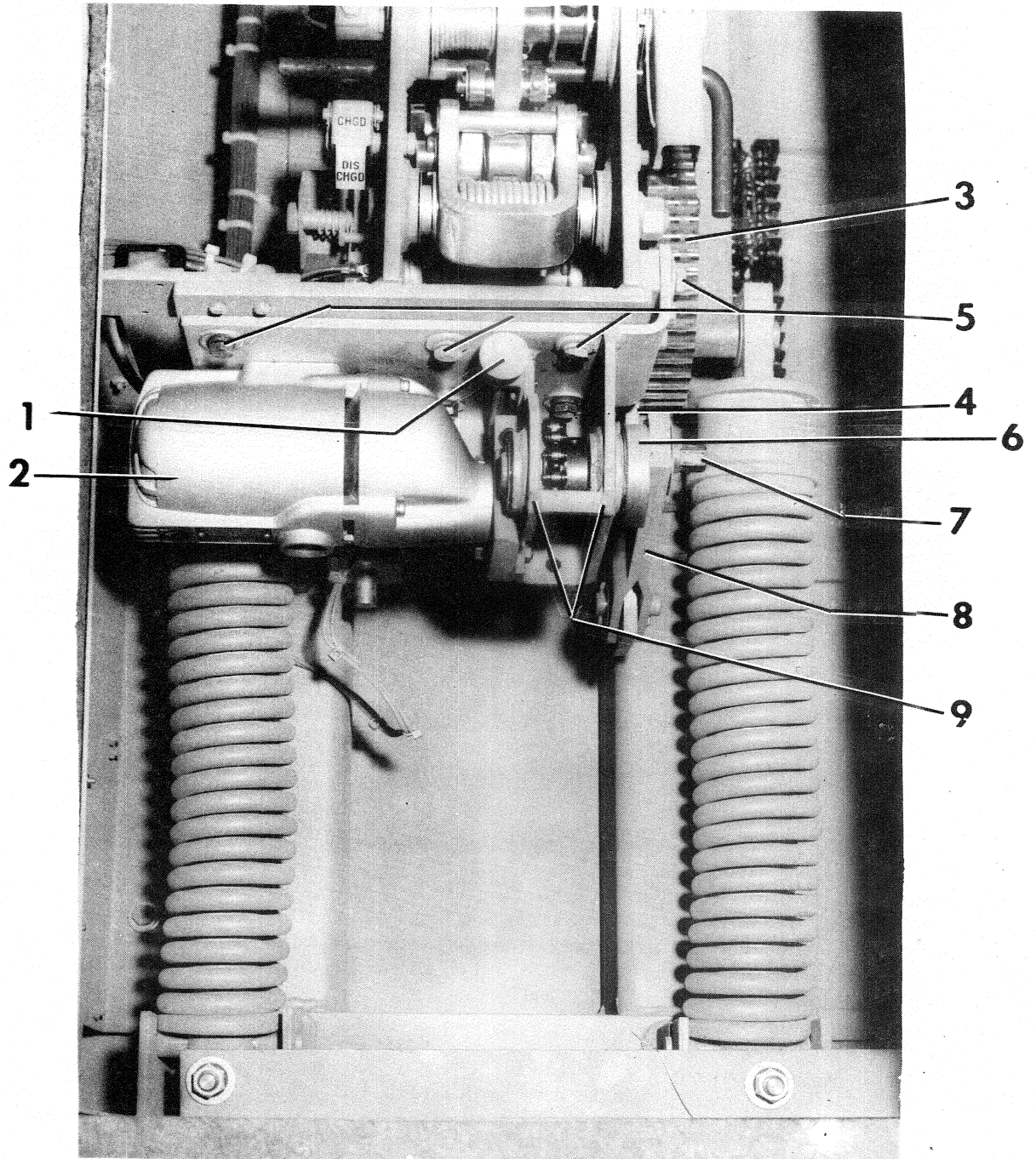
- 11. Trip Latch Checking Switch
- 12. Trip Latch Shaft
- 13. Charge-discharge Indicator Linkage
- 14. Charge-discharge Indicator
- 15. Switch Support Bolts
- 16. Motor Limit Switch Support
- 17. Motor Limit Switches
- 18. Motor Limit Switch Striker
- 19. Closing Latch
- 20. Control Panel
- 21. Control House Heater Circuit Fused Pullout
- 22. Cutoff and Anti-pump Relay (52Y)
- 23. Trip Latch Blocking Pin
- 24. Motor Circuit Fused Pullout (When Required)

Fig. 4 Left View of Mechanism

Fig. 4 (8042490)

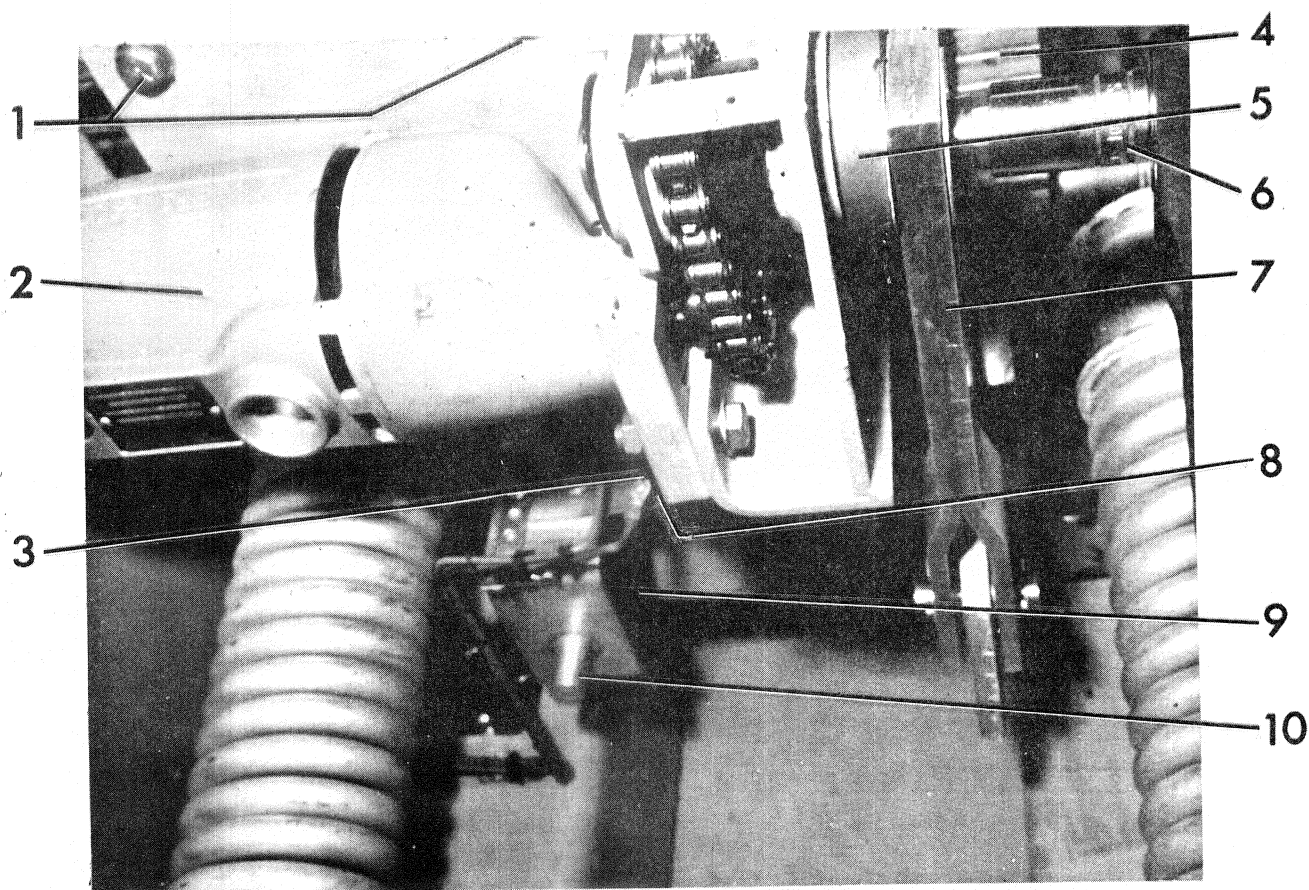


Fig. 5 (8042488)



- |                          |   |
|--------------------------|---|
| 1. Manual Close Push Rod | 6. Eccentric                              |
| 2. Spring-charging Motor | 7. Manual Charging Stud<br>(5/8 Inch Hex) |
| 3. Ratchet Wheel         | 8. Driving Link                           |
| 4. Driving Pawl          | 9. Motor Support and Bearing Housing      |
| 5. Motor Mounting Bolts  |   |

Fig. 5 Driving Elements



- |                                    |                                       |
|------------------------------------|---------------------------------------|
| 1. Motor Support Bolts             | 6. Manual Charging Stud and Wrench    |
| 2. Driving Motor                   | 7. Driving Link                       |
| 3. Closing Latch Monitoring Switch | 8. Monitoring Switch Mounting Bracket |
| 4. Ratchet Wheel                   | 9. Closing Coil (52CC)                |
| 5. Eccentric                       | 10. Closing Coil Plunger              |

Fig. 6 Closing Devices

the switch cam (6) until the motor limit switch striker (26) has traveled the maximum amount (about 180 degrees rotation of the cam). Loosen the mounting bolt (28) and rotate the switch support (16), Fig. 4, until the gap between the motor limit switch striker (26), Fig. 9, and the switch support (16), Fig. 4, is 0.032 to 0.005 inch.

#### CLOSING CAM CLEARANCE

Refer to Fig. 18. The sum of "C" plus "R" should not exceed 0.170 inch. This clearance is affected by the adjustment of the breaker opening dashpots, toggle setting (FKA), internal stops (FK), and vertical operating rod length. Normally no adjustment is required; however, this clearance should be checked if the breaker settings are changed. The closing cam clearance is reduced when the break-

er stroke is increased by lowering the dashpots and/or the toggle setting at its minimum (FKA) and/or internal stops at their minimums (FK) and/or shortening of the vertical operating rod.

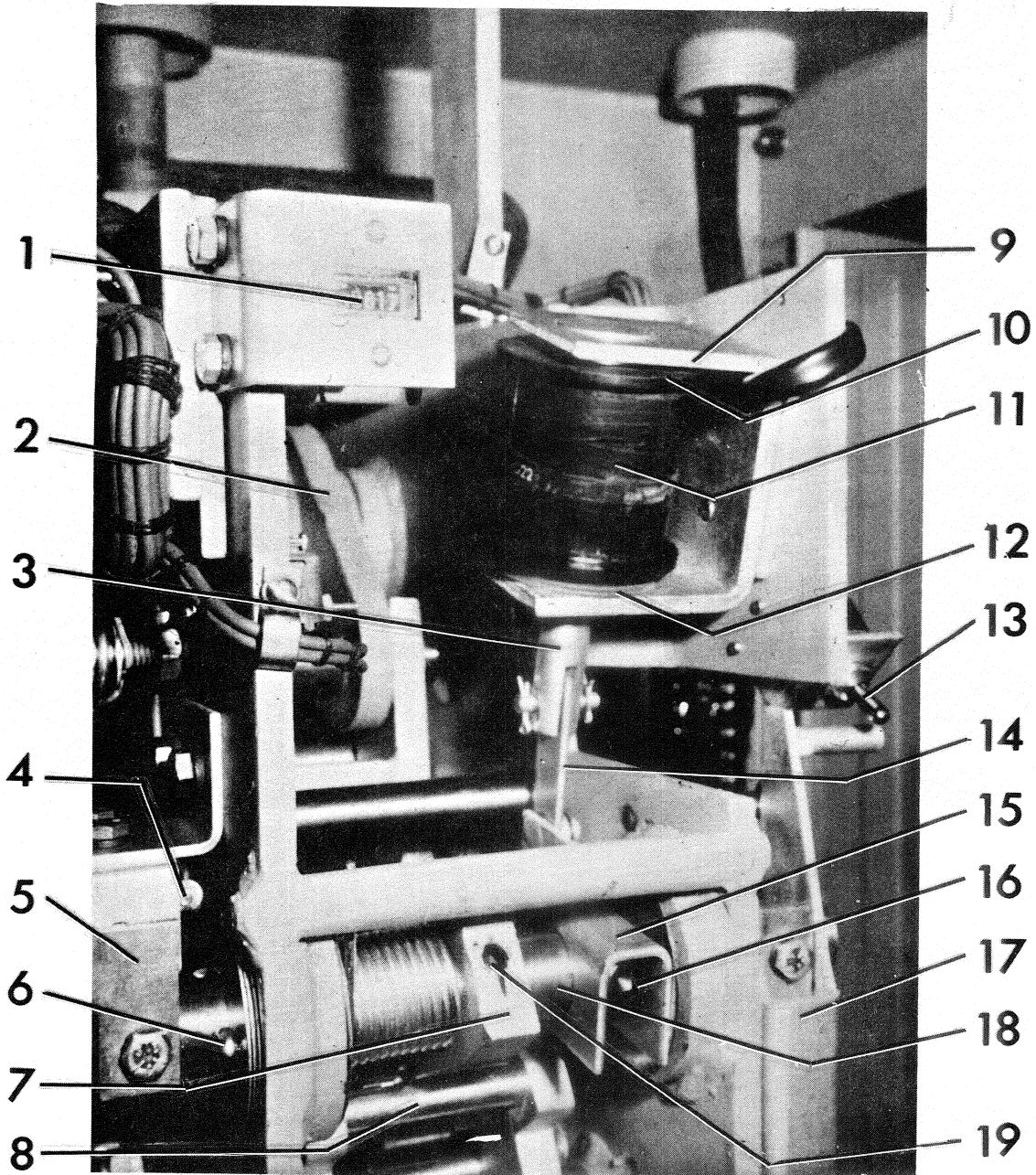
#### AUXILIARY SWITCH - TYPE SB-12

Refer to Fig. 11 and to "L", Fig. 15. The auxiliary switch (19), Fig. 11, is mounted on the left side of the operating mechanism frame (2). The linkage (59) attached to the pin (40), Fig. 10, of the output crank (4) operates the auxiliary switch shaft which opens and closes the "a" and "b" contacts. The "a" contacts are open when the breaker is open and the "b" contacts are open when the breaker is closed. The "a" contacts need only to be checked to make certain they are open when the breaker is open. The "b" contacts need only to be checked to see that they are open when the breaker

is closed. No adjustment is provided and a visual inspection is usually all that is required. If for some reason the auxiliary switch is removed it must be properly reinstalled. The "V" stamped on the SB-12 auxiliary switch shaft must point toward the switch terminals or 180 degrees away from the terminals to prevent overlap of the contacts. If "a" and "b" contacts overlap somewhat during the breaker stroke the auxiliary switch is assembled incorrectly and must be properly reset. Remove the switch operator from the square shaft. Rotate the square shaft until the arrow on the end of the shaft is pointing toward the upper front corner of the switch mounting plate with the breaker in the open position. Install the switch operator and make certain there is no overlap between the "a" and "b" contacts during the breaker stroke.

Fig. 6 (8915803E)

Fig. 7 (8915803C)



- |  |                                 |
|--|---------------------------------|
| 1. Operation Counter                             | 10. Trip Coil Positioning Shims |
| 2. Main Output Crank                             | 11. Trip Coil                   |
| 3. Trip Coil Plunger                             | 12. Trip Coil Positioning Shims |
| 4. Trip Latch Checking Switch                    | 13. Lock-out Device (69 Switch) |
| 5. Trip Latch Checking Switch<br>Operating Lever | 14. Trip Coil Link              |
| 6. Trip Shaft Retaining Cotter Pin               | 15. Trip Crank                  |
| 7. Trip Latch                                    | 16. Trip Crank Adjustment Bolt  |
| 8. Trip Latch Stop Pin                           | 17. Manual Trip Lever           |
| 9. Trip Coil Support Bracket                     | 18. Trip Latch Shaft            |
|  | 19. Trip Latch Set Screw        |

Fig. 7 Tripping Devices

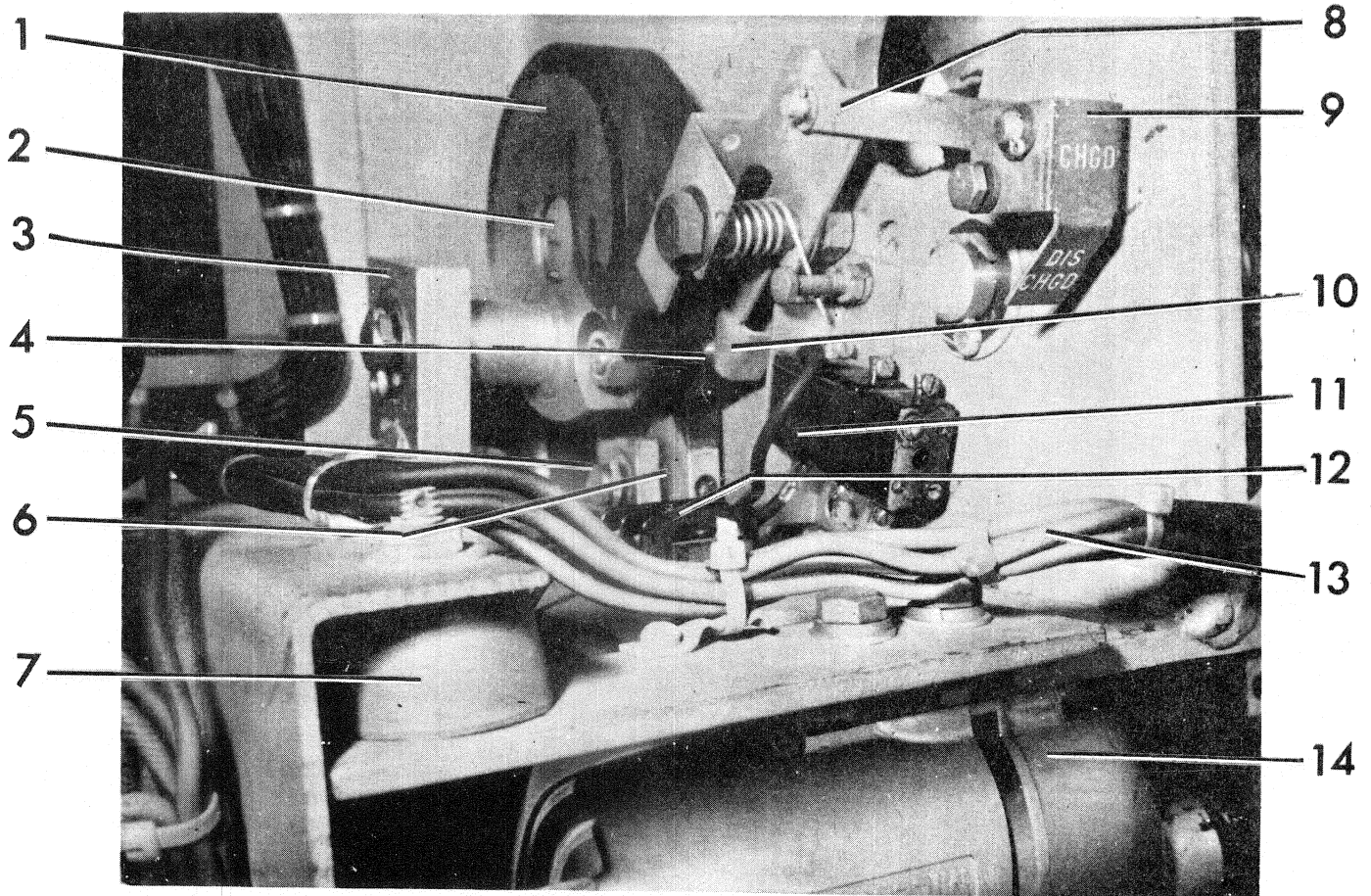


Fig. 8A (8915679B)

- |                         |                                       |                                   |
|-------------------------|---------------------------------------|-----------------------------------|
| 1. Limit Switch Cam     | 6. Closing Latch                      | 10. Motor Limit Switch Striker    |
| 2. Cam Shaft            | 7. Control Panel Shock Mount          | 11. Charging Motor Limit Switches |
| 3. Guide Block          | 8. Charge-discharge Indicator Linkage | 12. Motor Lead Terminal Board     |
| 4. Closing Latch Roller | 9. Charge-discharge Indicator         | 13. Control Wiring                |
| 5. Closing Latch Shaft  |                                       | 14. Spring-charging Motor         |

Fig. 8A Closing Latch and Motor Control

**DRIVING AND LATCHING PAWL  
ADJUSTMENT**

Refer to Fig. 12 and to "P" and "Q", Fig. 14. The driving pawl (74), Fig. 12, must advance the ratchet wheel (73) sufficiently on each stroke to allow the latching pawl (70) to fall into the ratchet teeth of the ratchet wheel. This should be checked with a major portion of the closing spring load against the driving members. With the mechanism unblocked, manually charge the closing springs with the manual charging wrench (7), Fig. 5, until they are slightly more than half charged. Slowly rotate the charging wrench until the driving pawl (74), Fig. 12, has tra-

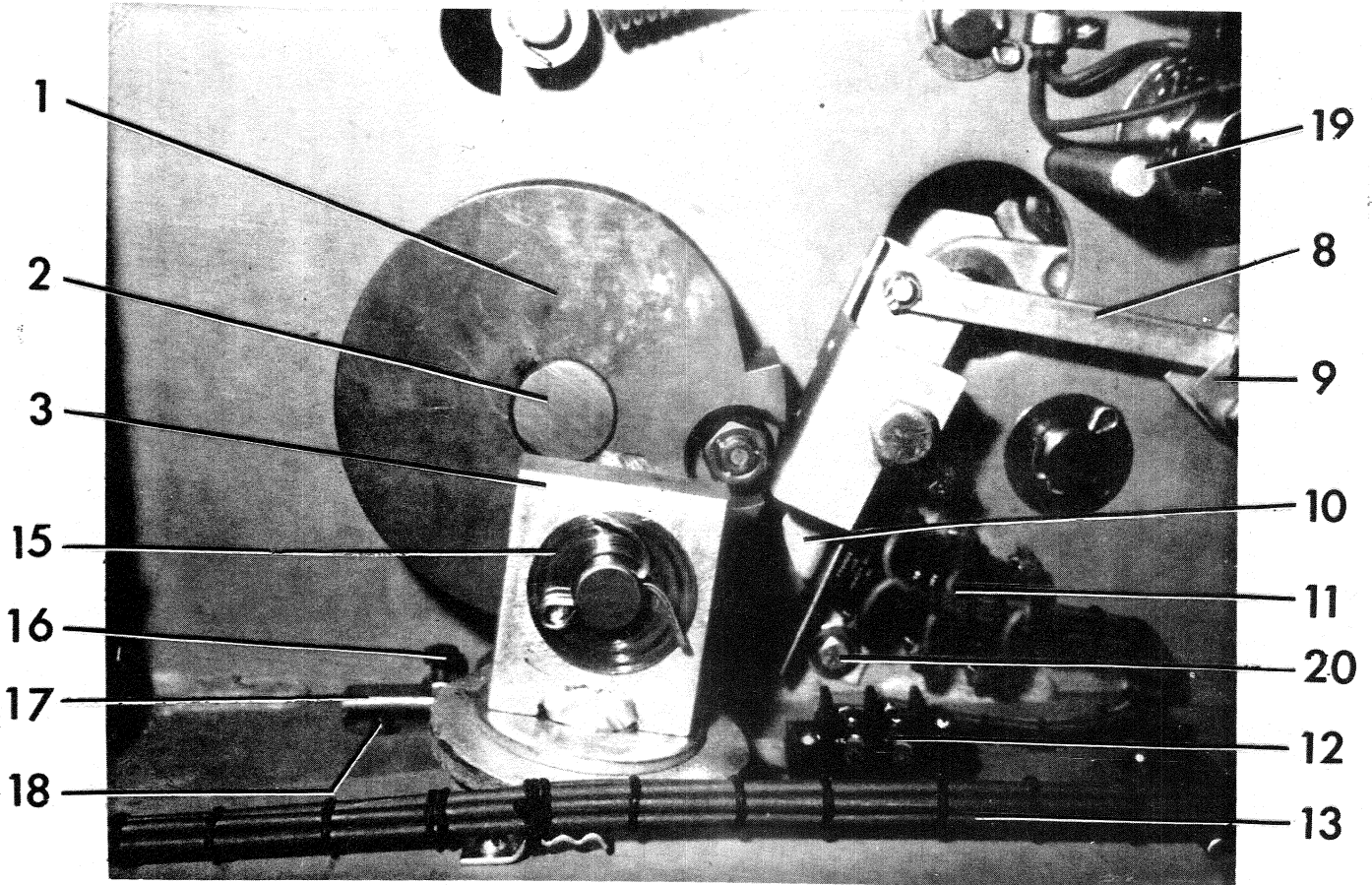
veled through its return stroke and check the maximum driving clearance between the driving pawl and the ratchet tooth "Q", Fig. 14. Rotate the charging wrench until the driving pawl has advanced the ratchet tooth to its maximum travel. Now check the latching clearance between the ratchet tooth and the latching pawl (70), "P", Fig. 14. The clearance should be approximately equal for both the driving and latching pawls and not less than 0.040 inch in either case when a feeler gage is inserted to approximately one-half the depth of the ratchet tooth and between the driven portion of the ratchet tooth and the flat above the tip of the pawl, 0.040 inch is a good place to start

to adjust the motor mount for proper ratcheting. This corresponds to a 0.015 inch clearance between the tip of the ratchet tooth and the tip of the pawl as the pawl falls past the ratchet tooth.

If for some reason the 0.040 inch clearance cannot be maintained a somewhat less amount is satisfactory provided the mechanism will slowly close the breaker when operated manually or close the breaker normally when operated electrically and that the springs can be charged manually or electrically.

If adjustment is required for either pawl the closing springs must first be fully charged and blocked. Remove roll

Fig. 8B (8915803B)



- |                              |   |  |
|------------------------------|---|--|
| 1. Limit Switch Cam          | 8. Charge-discharge Indicator Linkage   | 15. Guide Block Roller Bearing         |
| 2. Cam Shaft                 | 9. Charge-discharge Indicator           | 16. Closing Latch Wipe Adjusting Screw |
| 3. Guide Block               | 10. Charging Motor Limit Switch Striker | 17. Closing Latch                      |
| 4. Closing Latch Roller      | 11. Charging Motor Limit Switches       | 18. Closing Coil Plunger               |
| 5. Closing Latch Shaft       | 12. Motor Lead Terminal Board           | 19. Trip Latch Safety Rod              |
| 6. Closing Latch             | 13. Control Wiring                      | 20. Motor Limit Switch Adjusting Screw |
| 7. Control Panel Shock Mount | 14. Spring-charging Motor               |  |

Fig. 8B Mechanism Open - Trip Latch in Place (Springs Discharged)

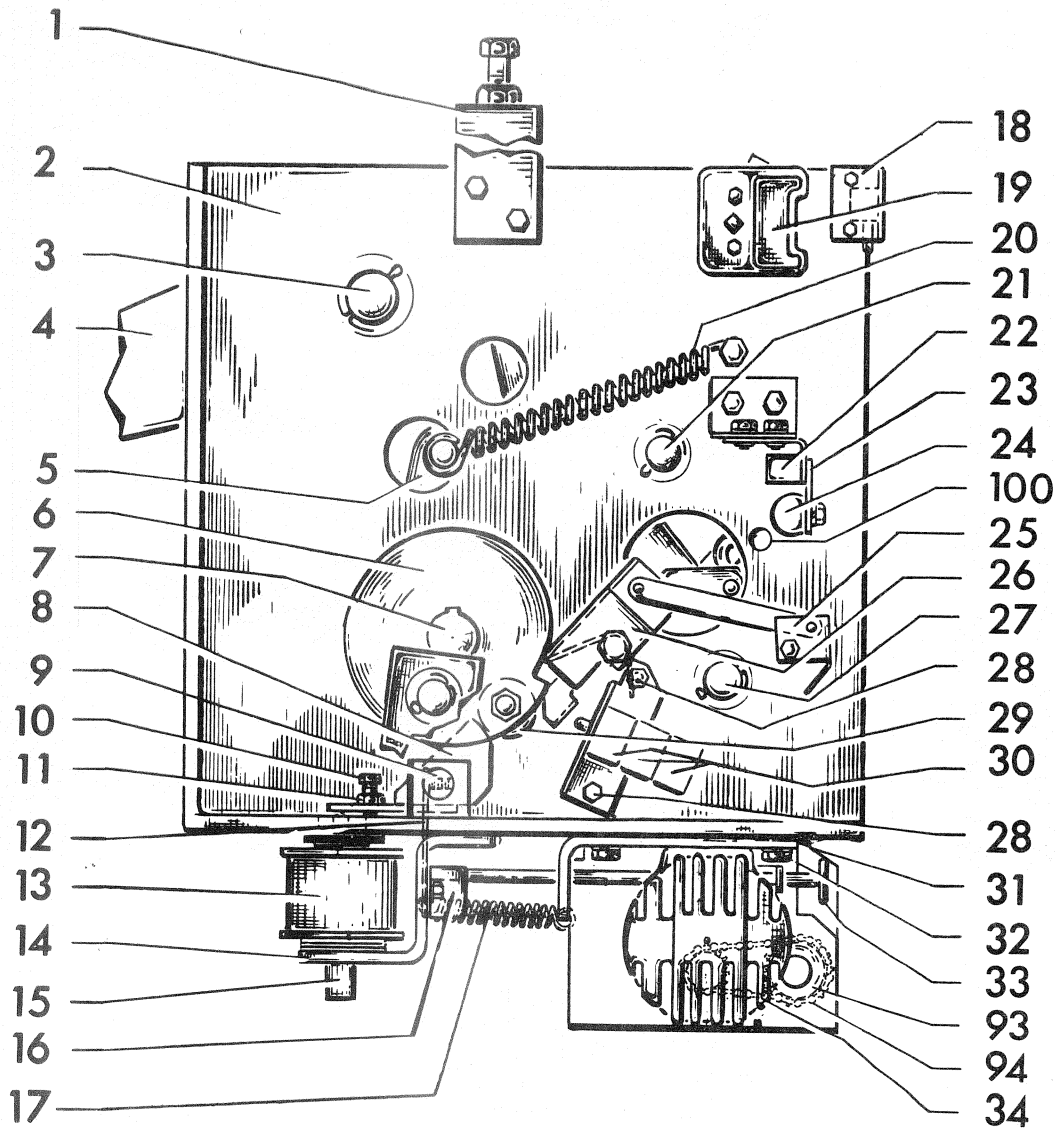
pin from right side of motor mounting plate by driving the pin through the side plate. Loosen the motor mounting bolts (5), Fig. 5, and move the entire motor assembly to the rear toward the breaker tanks if the clearance is under the minimum at the latching and safety pawls, and, to the front away from the breaker tanks if the clearance is under the minimum at the driving pawl. Move the motor assembly approximately twice the dimensional increase required at the pawl. Move the entire motor and motor-mount assembly in 1/64 inch increments as a small movement here results in a large movement at the pawls. Be certain the motor

assembly is moved straight forward or rearward and tighten the one bolt on the right side of the mounting frame first to assure proper alignment. After tightening the remaining bolts the springs should be released and the clearance again checked as described above. Redrill and pin in the same area to prevent movement.

#### LATCHING PAWL TO RATCHET WHEEL CLEARANCE

Refer to Fig. 12 and to "H", Fig. 14. The latching pawl (70), Fig. 12 (which is the outboard pawl at this location) must

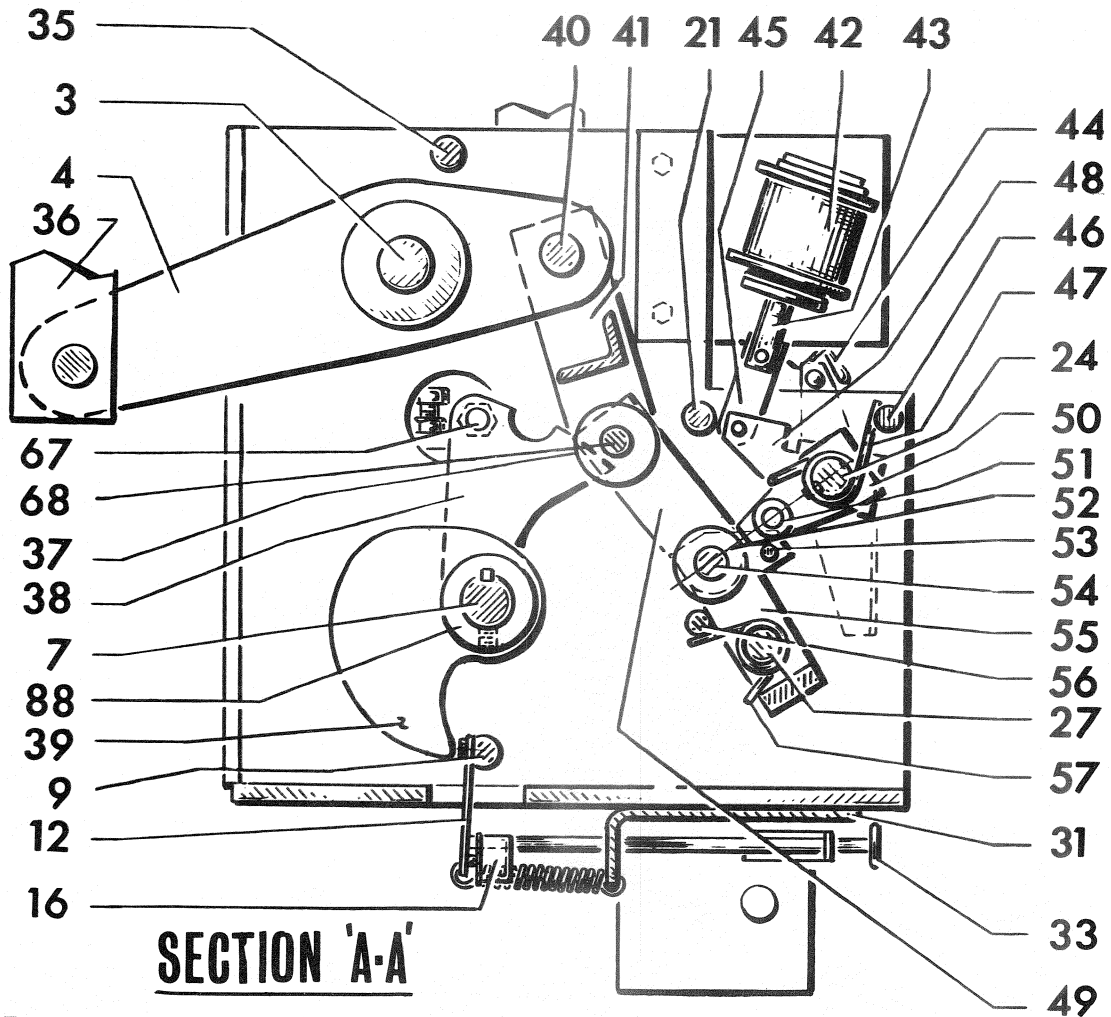
have a 0.015 to 0.030 inch clearance above the teeth of the ratchet wheel (73) when the closing spring (62) and (79), Fig. 11, are completely charged, "H", Fig. 14. This is checked with the closing springs completely closed and gaged by measuring the distance between the outboard latching pawl and the ratchet tooth with the pawl raised as high as possible. This is adjusted by loosening the locknut (86), Fig. 12, and adjusting the latching and safety pawls' adjustment screw (69), Fig. 12, as necessary. The safety pawl (inboard of the latching pawl) will then have up to a 0.060 inch clearance more than the latching pawl.



- |   |  |   |
|---|--|---|
| 1. Mechanism House Support Bracket                  | 15. Closing Coil Plunger                       | 30. Motor Limit Switches                  |
| 2. Mechanism Frame                                  | 16. Closing Latch Monitoring Switch            | 31. Motor Support Bracket                 |
| 3. Output Crank Main Shaft                          | 17. Closing Latch Spring                       | 32. Motor Support Bracket Bolts           |
| 4. Output Crank                                     | 18. Operation Counter                          | 33. Manual Close Push Rod Button          |
| 5. Prop   | 19. Auxiliary Switch                           | 34. Spring-charging Motor                 |
| 6. Limit Switch Cam                                 | 20. Prop Reset Spring                          | 35. Mechanism Frame Tie Rod               |
| 7. Cam Shaft  | 21. Stop Pin                                   | 36. Vertical Operating Rod Lower Coupling |
| 8. Closing Latch                                    | 22. Trip Latch Checking Switch                 | 37. Cam Follower Roller                   |
| 9. Closing Latch Shaft                              | 23. Trip Latch Checking Switch Operating Lever | 38. Closing Prop                          |
| 10. Closing Latch Wipe Adjusting Screw              | 24. Trip Latch Shaft                           | 39. Cam                                   |
| 11. Closing Latch Wipe Adjusting Screw Locknut      | 25. Charged-discharged Indicator               | 40. Linkage to Output Crankshaft          |
| 12. Closing Latch Monitoring Switch Operating Lever | 26. Motor Limit Switch Striker                 | 41. Upper Link                            |
| 13. Closing Coil                                    | 27. Link Shaft                                 | 42. Trip Coil                             |
| 14. Closing Coil Support Bracket                    | 28. Motor Limit Switch Support Bolts           | 43. Trip Coil Plunger                     |
|   | 29. Closing Latch Roller                       | 44. Lock-out Switch (69 device)           |
|   |  | 45. Trip Coil Linkage                     |

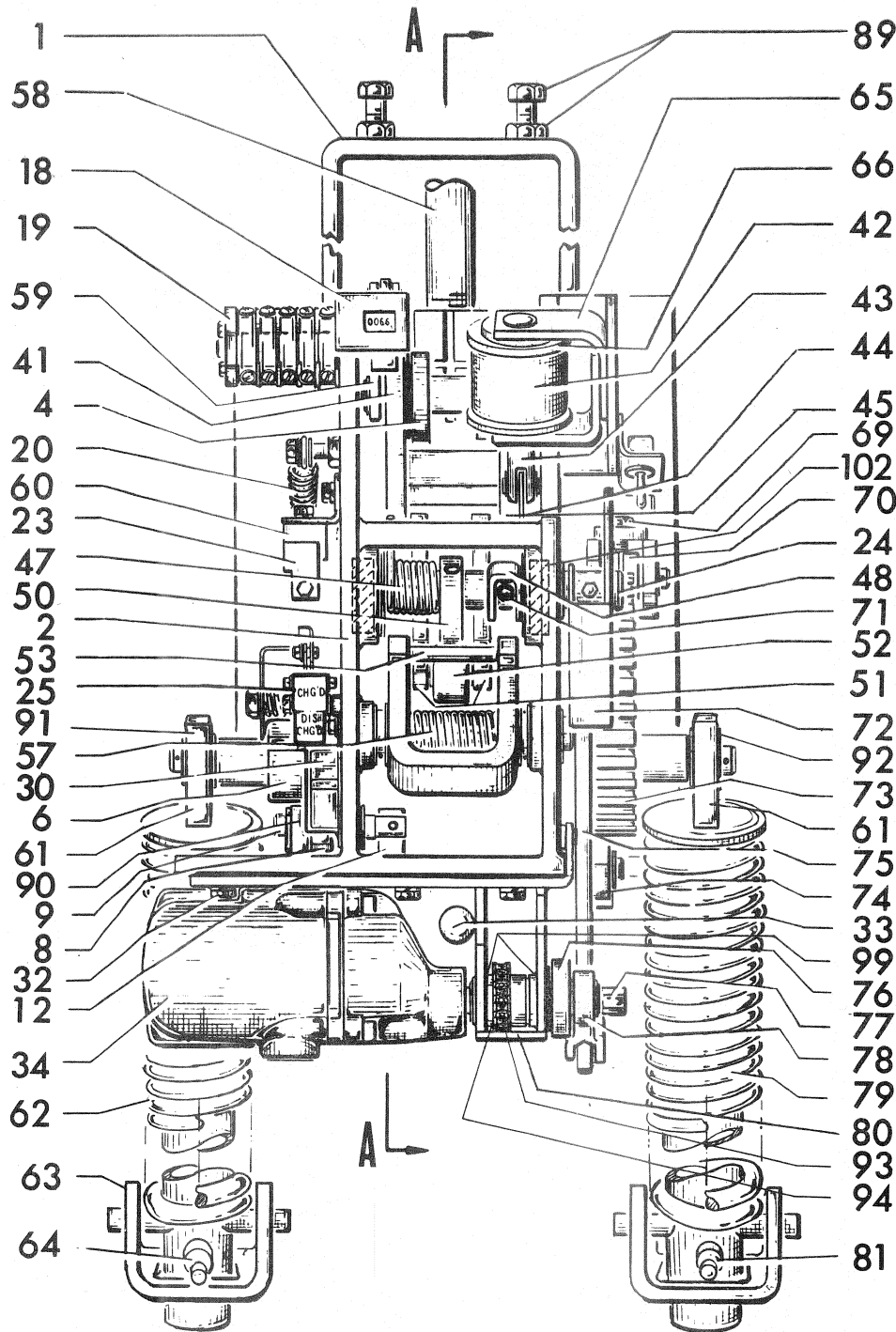
Fig. 9. Left Side View of the Mechanism Linkage in the Latch Closed Position (Spring-charged)

Fig. 10 (0832D0149 Sheet 2, View IV Rev. 1)



- |   |  |  |
|---|--|--|
| 46. Mechanism Frame Tie Rod                         | 65. Trip Coil Support                            | 84. Trip Latch Clearance Adjustment Locking Nut  |
| 47. Trip Latch Spring                               | 66. Trip Coil Shims                              | 85. Vertical Operating Rod Locking Bolt          |
| 48. Trip Crank                                      | 67. Prop Spacer and Reset Spring Pin             | 86. Latching and Safety Pawls Adjustment Locknut |
| 49. Lower Link                                      | 68. Cam Follower Roller Shaft                    | 87. Driving Pawl Return Spring                   |
| 50. Trip Latch                                      | 69. Latching and Safety Pawls Adjustment Screw   | 88. Cam Shaft Bearing                            |
| 51. Trip Latch Guide Roller                         | 70. Latching Pawl                                | 89. Mechanism House Adjusting Bolt and Locknut   |
| 52. Trip Latch Roller                               | 71. Trip Coil Linkage Adjustment Allen Head Bolt | 90. Closing Latch Bearing                        |
| 53. Trip Latch Stop Pin                             | 72. Manual Trip Lever                            | 91. Left Guide Block Bearing                     |
| 54. Trip Latch Roller Shaft                         | 73. Ratchet Wheel                                | 92. Right Guide Block Bearing                    |
| 55. Trip Latch Assembly Support Link                | 74. Driving Pawl                                 | 93. Sprocket                                     |
| 56. Trip Latch Clearance Adjustment Eccentric Shaft | 75. Driving Crank                                | 94. Driving Chain                                |
| 57. Trip Latch Assembly Support Link Spring         | 76. Driving Eccentric                            | 95. Driving Eccentric Bearing                    |
| 58. Breaker Vertical Operating Rod                  | 77. Manual Charging Stud                         | 96. Driving Link Bushing                         |
| 59. Auxiliary Switch Operating Linkage              | 78. Driving Link                                 | 97. Driving Pawl Bushing                         |
| 60. Trip Latch Checking Switch Support              | 79. Right Closing Spring                         | 98. Driving Crank Bushing                        |
| 61. Guide Block                                     | 80. Motor Support Bracket                        | 99. Sprocket Shaft Bushing                       |
| 62. Left Closing Spring                             | 81. Right Closing Spring Blocking Device         | 100. Trip Latch Blocking Pin Hole                |
| 63. Closing Spring Support                          | 82. Manual Trip Adjusting Bolt                   | 101. Locking Nut                                 |
| 64. Left Closing Spring Blocking Device             | 83. Manual Trip Locking Nut                      | 102. Trip Latch Roller Shaft Bearing             |

Fig. 10 Left Side Sectional View of the Mechanism Linkage in the Latch Closed Position



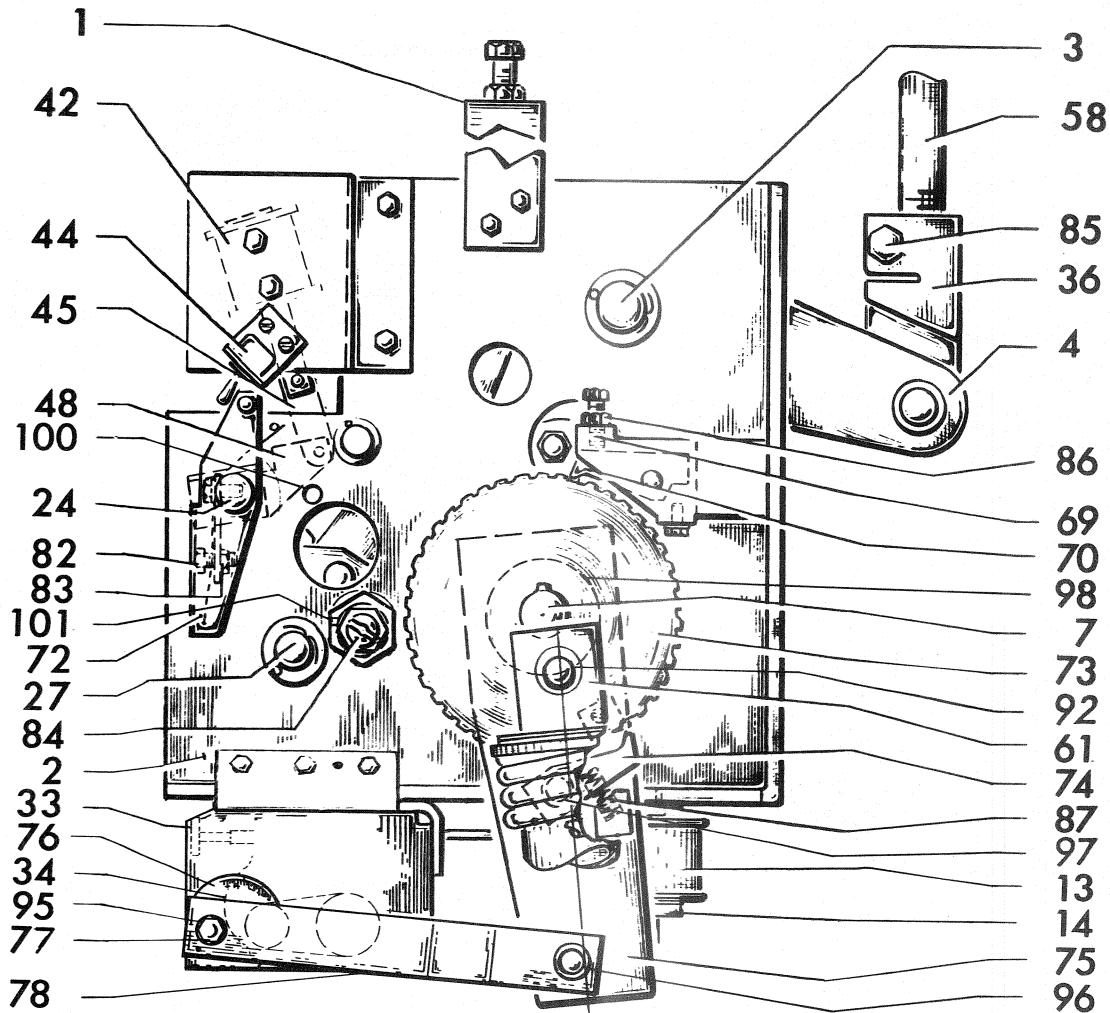
1. Mechanism House Support Bracket
2. Mechanism Frame
3. Output Crank Main Shaft
4. Output Crank
5. Prop
6. Limit Switch Cam
7. Cam Shaft
8. Closing Latch
9. Closing Latch Shaft
10. Closing Latch Wipe Adjusting Screw
11. Closing Latch Wipe Adjusting Screw Locknut
12. Closing Latch Monitoring Switch Operating Lever
13. Closing Coil
14. Closing Coil Support Bracket
15. Closing Coil Plunger
16. Closing Latch Monitoring Switch
17. Closing Latch Spring
18. Operation Counter
19. Auxiliary Switch
20. Prop Reset Spring
21. Stop Pin
22. Trip Latch Checking Switch
23. Trip Latch Checking Switch Operating Lever
24. Trip Latch Shaft
25. Charged-discharged Indicator
26. Motor Limit Switch Striker
27. Link Shaft
28. Motor Limit Switch Support Bolts
29. Closing Latch Roller
30. Motor Limit Switches
31. Motor Support Bracket
32. Motor Support Bracket Bolts
33. Manual Close Push Rod Button
34. Spring-charging Motor
35. Mechanism Frame Tie Rod
36. Vertical Operating Rod Lower Coupling
37. Cam Follower Roller
38. Closing Prop
39. Cam
40. Linkage to Output Crankshaft
41. Upper Link
42. Trip Coil
43. Trip Coil Plunger
44. Lock-out Switch (69 device)
45. Trip Coil Linkage
46. Mechanism Frame Tie Rod
47. Trip Latch Spring
48. Trip Crank
49. Lower Link
50. Trip Latch
51. Trip Latch Guide Roller
52. Trip Latch Roller
58. [Unlabeled]
59. [Unlabeled]
60. [Unlabeled]
61. [Unlabeled]
62. [Unlabeled]
63. [Unlabeled]
64. [Unlabeled]
65. [Unlabeled]
66. [Unlabeled]
69. [Unlabeled]
70. [Unlabeled]
71. [Unlabeled]
72. [Unlabeled]
73. [Unlabeled]
74. [Unlabeled]
75. [Unlabeled]
76. [Unlabeled]
77. [Unlabeled]
78. [Unlabeled]
79. [Unlabeled]
80. [Unlabeled]
81. [Unlabeled]
89. [Unlabeled]
90. [Unlabeled]
91. [Unlabeled]
92. [Unlabeled]
93. [Unlabeled]
94. [Unlabeled]

Fig. 11 (0832D0149 Sheet 1, View I Rev. 5)

Fig. 11. Front View of the Mechanism in the Latch Closed Position



Fig. 12 (0832D0149 Sheet 1, View II Rev. 5)



- |   |  |  |
|---|--|--|
| 53. Trip Latch Stop Pin                             | 69. Latching and Safety Pawls Adjustment Screw   | 85. Vertical Operating Rod Locking Bolt          |
| 54. Trip Latch Roller Shaft                         | 70. Latching Pawl                                | 86. Latching and Safety Pawls Adjustment Locknut |
| 55. Trip Latch Assembly Support Link                | 71. Trip Coil Linkage Adjustment Allen Head Bolt | 87. Driving Pawl Return Spring                   |
| 56. Trip Latch Clearance Adjustment Eccentric Shaft | 72. Manual Trip Lever                            | 88. Cam Shaft Bearing                            |
| 57. Trip Latch Assembly Support Link Spring         | 73. Ratchet Wheel                                | 89. Mechanism House Adjusting Bolt and Locknut   |
| 58. Breaker Vertical Operating Rod                  | 74. Driving Pawl                                 | 90. Closing Latch Bearing                        |
| 59. Auxiliary Switch Operating Linkage              | 75. Driving Crank                                | 91. Left Guide Block Bearing                     |
| 60. Trip Latch Checking Switch Support              | 76. Driving Eccentric                            | 92. Right Guide Block Bearing                    |
| 61. Guide Block                                     | 77. Manual Charging Stud                         | 93. Sprocket                                     |
| 62. Left Closing Spring                             | 78. Driving Link                                 | 94. Driving Chain                                |
| 63. Closing Spring Support                          | 79. Right Closing Spring                         | 95. Driving Eccentric Bearing                    |
| 64. Left Closing Spring Blocking Device             | 80. Motor Support Bracket                        | 96. Driving Link Bushing                         |
| 65. Trip Coil Support                               | 81. Right Closing Spring Blocking Device         | 97. Driving Pawl Bushing                         |
| 66. Trip Coil Shims                                 | 82. Manual Trip Adjusting Bolt                   | 98. Driving Crank Bushing                        |
| 67. Prop Spacer and Reset Spring Pin                | 83. Manual Trip Locking Nut                      | 99. Sprocket Shaft Bushing                       |
| 68. Cam Follower Roller Shaft                       | 84. Trip Latch Clearance Adjustment Locking Nut  | 100. Trip Latch Blocking Pin Hole                |
|   |  | 101. Locking Nut                                 |
|   |  | 102. Trip Latch Roller Shaft Bearing             |

Fig. 12 Right Side View of the Mechanism in the Latch Closed Position

This can also be checked by measuring the distance between the bottom of the latching and safety adjustment screw and the top surface of the latching pawl when the closing springs are completely charged.

**TRIP LATCH CHECKING SWITCH**

Refer to Fig. 10 and to "Y" and "W", Fig. 15. Rotate the trip latch (50), Fig. 10, clockwise (looking at the left side of the mechanism) by pressing the manual trip lever (17), Fig. 7, to open the latch checking switch operating lever (23), Fig. 9. Allow the trip latch to reset slowly and determine the point at which the contacts of the trip latch checking switch (22) make by using a circuit continuity tester, such as a light indicator or bell set. The contacts of the trip latch checking switch should just make when there is a 1/16 inch gap between the trip latch (50), Fig. 10, and the stop pin (53) located on the trip latch assembly support link (55). There should be a minimum of 1/64 inch between the operating lever (5), Fig. 7, and the trip latch checking switch (22), Fig. 9. Bend the trip latch checking switch operating lever (23), Fig. 9, as necessary to adjust.

**TRIP COIL PLUNGER**

Refer to Fig. 10 and "S", Fig. 13. The plunger (43) of the trip coil (42) must have a minimum of 1/8 inch free travel before the trip latch (50) starts to move to provide proper tripping at reduced voltages. This is adjusted by loosening the Allen set screw which is located in the trip latch shaft (24). This set screw bears against the Allen head bolt (71), Fig. 11, securing the bolt in place. Rotate the trip crank (48), Fig. 10, about the trip latch shaft until the correct free travel of the trip coil plunger is obtained. Adjust the Allen head bolt to contact the trip crank at this point. Install the Allen screw from the front side of the trip latch shaft from the front side of the trip latch shaft then tighten the Allen head adjusting bolt (71), Fig. 11. This free travel must be sufficient so that the breaker is able to trip at its minimum trip voltage. The values are in a chart under FINAL INSPECTION.

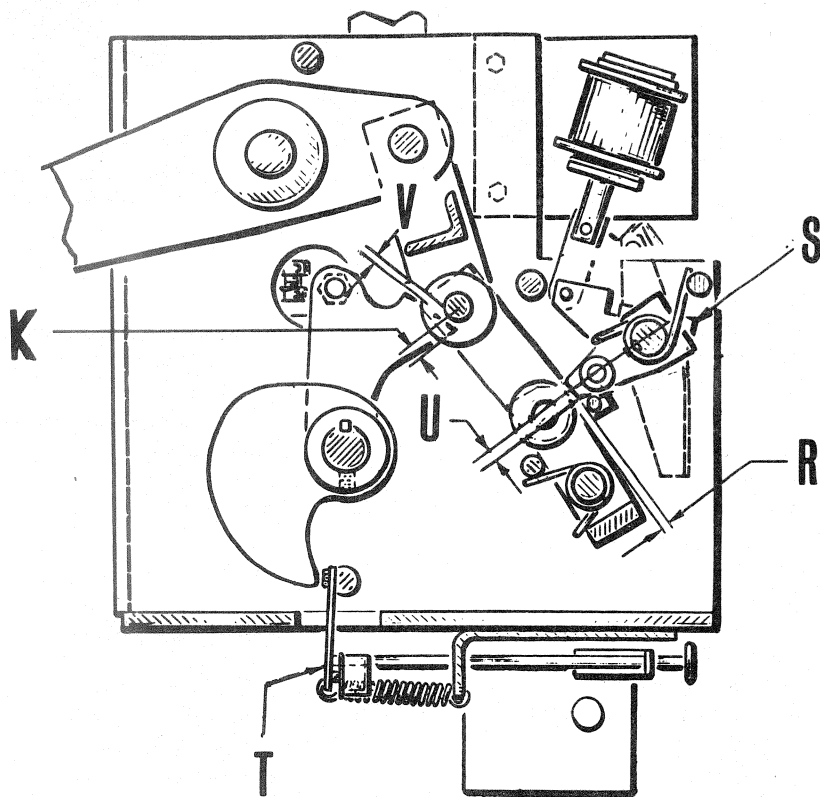
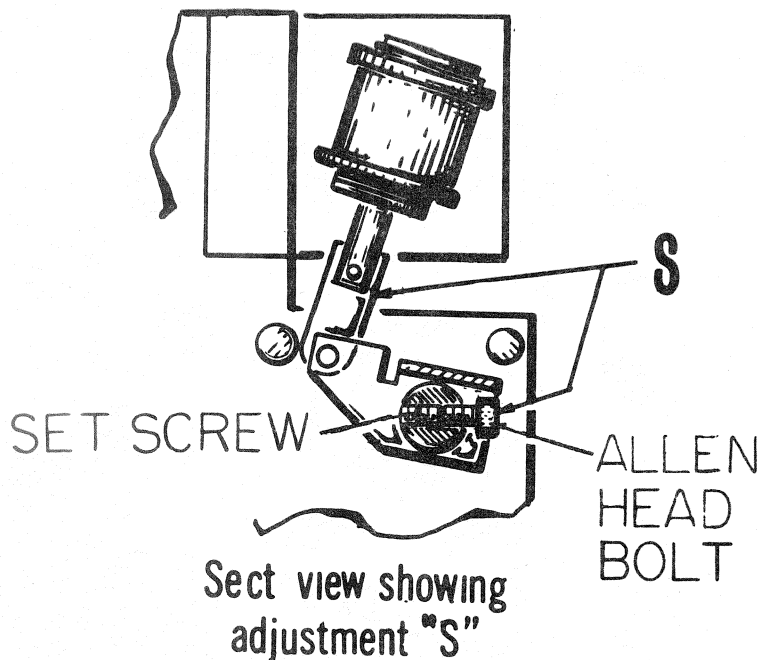


Fig. 13 Adjustment and Final Clearance Checks

Fig. 13 (0832D0149 Sheet 3, View VII and IX Rev. 4)

Fig. 14 (0832D0149 Sheet 3, View VIII Rev. 4)

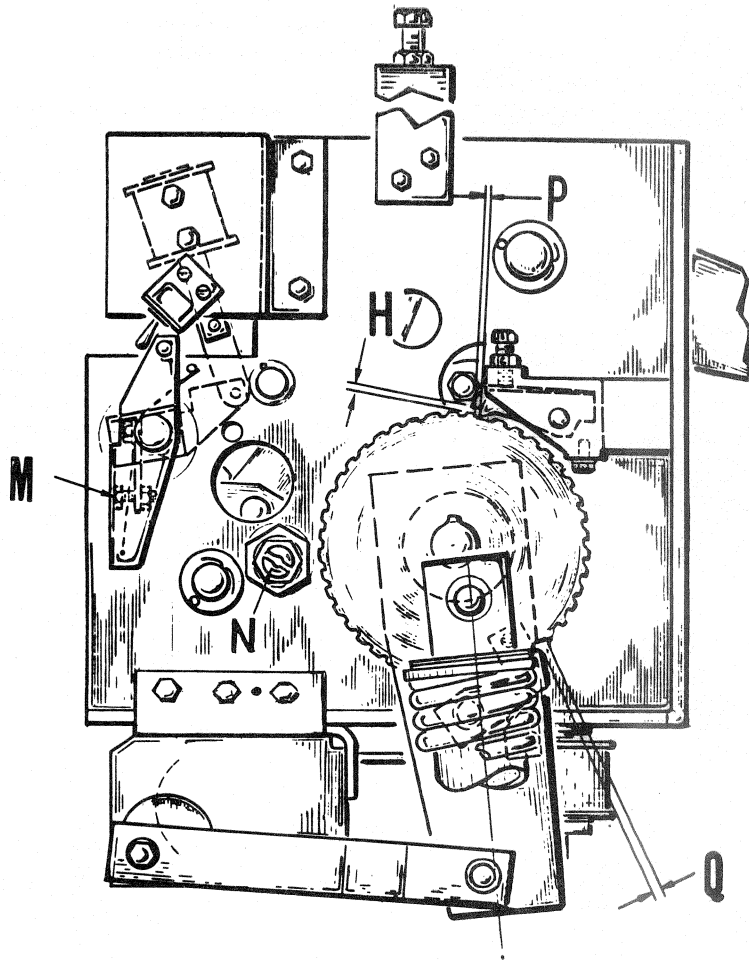


Fig. 14 Right Side View Adjustment and Final Clearance Checks

Fig. 14A (0832D0149 Sheet 3, View VIa Rev. 4)

direction. Tighten the locknut after adjusting.

**RECLOSING TIME-DELAY RELAY (79X)**

This relay is an optional feature for those who desire an adjustable reclosing operation.

The reclosing cycle must be set up so that the breaker contacts open at least the minimum distance which is given in the breaker instruction book before the contacts start to reclose. The point at which they start to reclose is determined by the breaker opening speed and the setting of the time-delay relay which initiates the reclosing circuit. The operating voltage is given on the breaker nameplate and the proper opening and closing speeds are given in the breaker instruction book.

**FINAL INSPECTION**

After the mechanism has been installed with all mechanical and electrical

**CLOSING COIL PLUNGER**

Refer to Fig. 9 and "F", Fig. 15. The closing coil plunger (15) of the closing coil (13) must have a minimum of 1/8 inch free travel before the tang of the closing latch is contacted. If this free travel is less than 1/8 inch, remove the coil and file the plunger (18), Fig. 8B, until it has 1/8 inch free travel.

**MANUAL TRIP LEVER**

Refer to Fig. 2 and "M", Fig. 14. The manual trip lever (19), Fig. 2, must be adjusted so that when the push button (21), Fig. 2, is activated the mechanism trips and the 69 device (17), Fig. 2, is operated. This is adjusted by loosening the locknut (83), Fig. 12, and turning the adjusting bolt (82), Fig. 12, in the proper

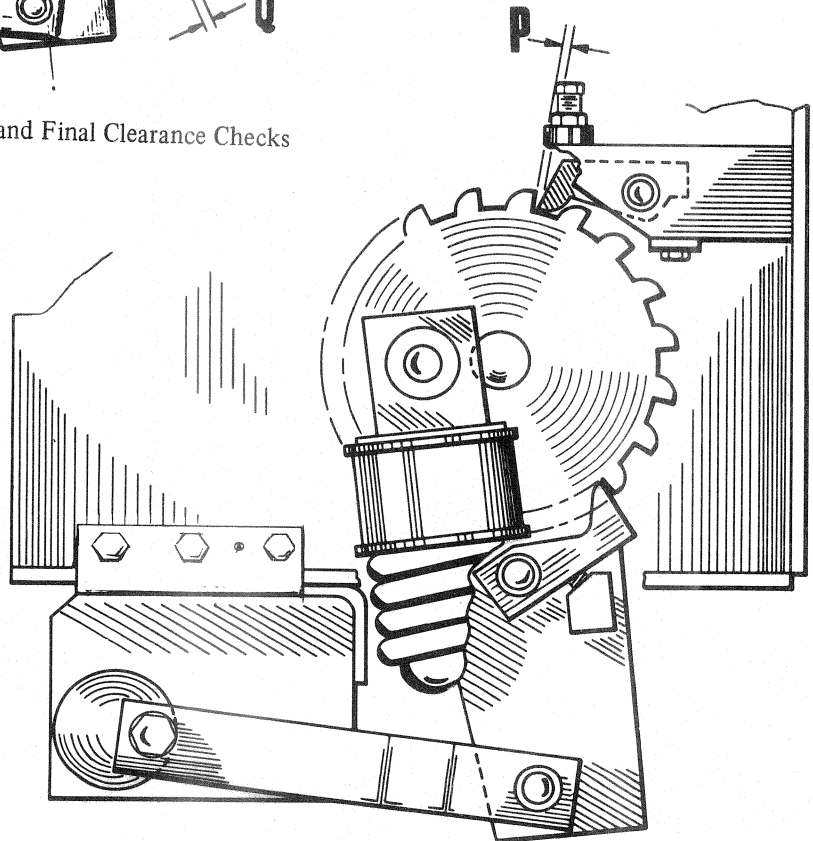


Fig. 14A Sectional View Showing Adjustment P

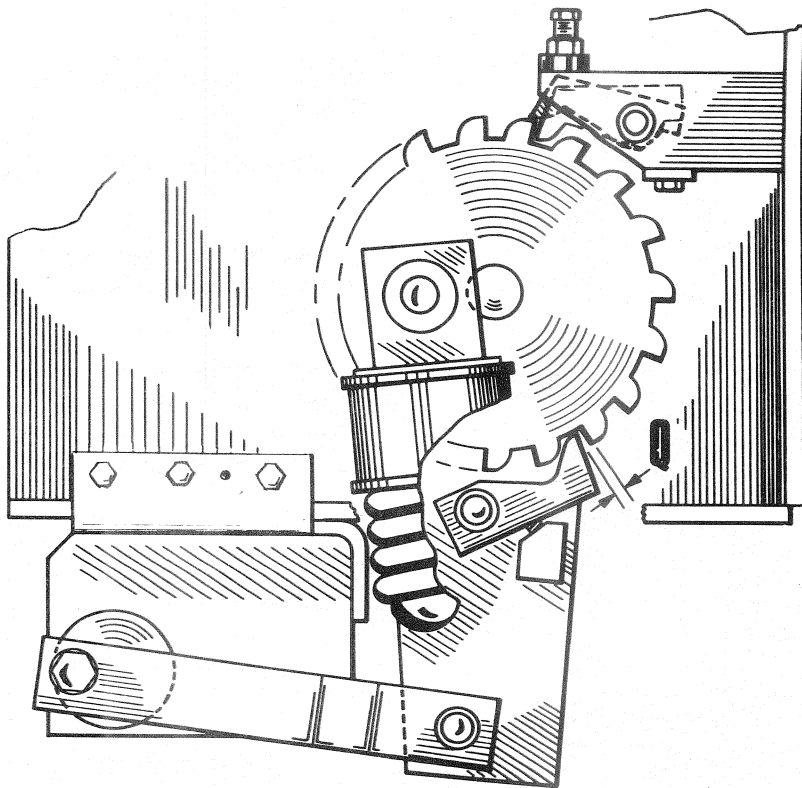


Fig. 14B Sectional View Showing Adjustment Q

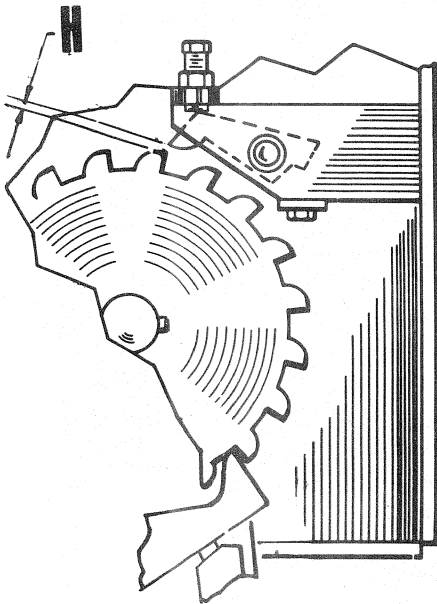


Fig. 14C Sectional View Showing Adjustment H

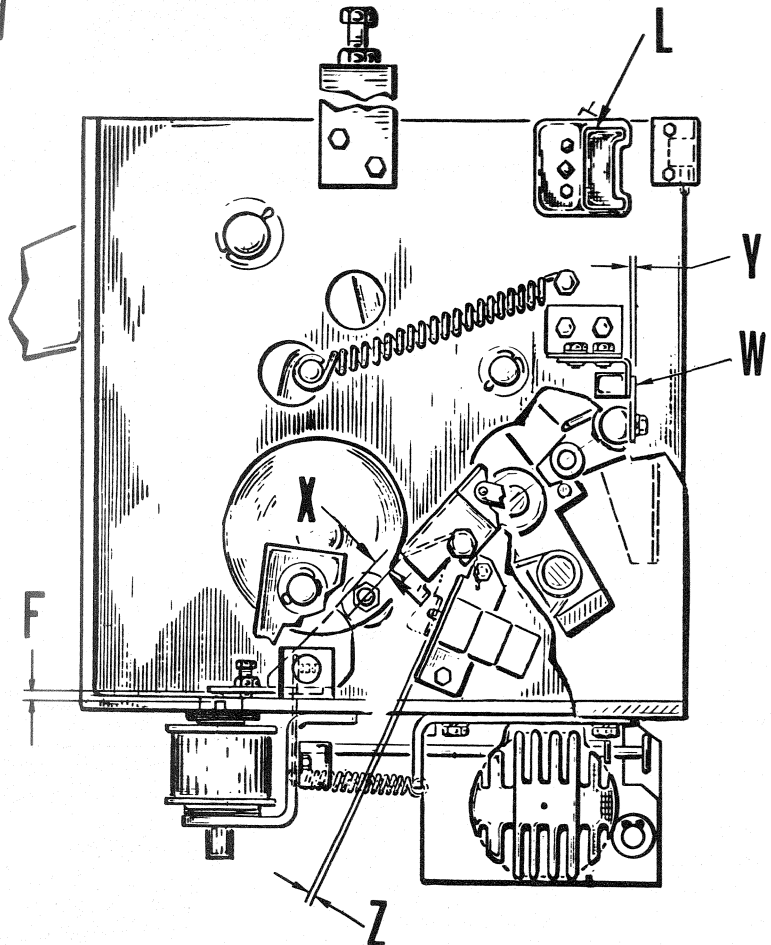


Fig. 15 Left Side View Adjustment and Final Clearance Checks

connections completed, make the following inspection and test:

- A. See that the mechanism is properly set up and securely fastened to the breaker framework.
- B. Review the following adjustments:
- C. Check that all bolts, nuts and screws are properly tightened and that all washers and cotter pins are in place with cotter pin ends effectively bent over.
- D. Inspect all wiring for damage during installation work, check terminal connections for loose screws, and test for possible grounds or short circuits.
- E. See that all bearing surfaces and

Fig. 14B (0832D0149 Sheet 3, View VIIb Rev. 4)

Fig. 14C (0832D0149 Sheet 3, View VIc Rev. 4)

Fig. 15 (0832D0149 Sheet 3 View V Rev. 4)

1. Trip latch wipe (with trip latch resting against stop pin) . . . . .	(U Fig. 13)	3/16 inch to 1/4 inch
2. Trip latch clearance . . . . .	(R Fig. 13)	1/32 inch to 3/32 inch
3. Trip latch nominal clearance . . . . .	(R Fig. 13)	0.045 inch
4. Closing prop clearance . . . . .	(V Fig. 13)	1/16 inch to 5/32 inch
5. Closing prop wipe . . . . .	(K Fig. 13)	3/16 inch to 3/8 inch
6. Closing latch wipe . . . . .	(X Fig. 15)	3/16 inch to 1/4 inch
7. Closing latch monitoring switch ("CL/MS") clearance . . . . .	(T Fig. 13)	0.005 to 0.032 inch
8. Motor limit switches ("SM/LS") maximum clearance. . . . .	(Z Fig. 15)	1/32 inch
9. Driving pawl minimum driving clearance . . . . .	(Q Fig. 14)	0.040 inch
10. Latching pawl minimum latching clearance . . . . .	(P Fig. 14)	0.040 inch
11. Latching pawl-ratchet wheel clearance . . . . .	(H Fig. 14)	0.015 to 0.030 inch
The driving pawl and latching pawl clearance should be approximately equal.		
12. Trip latch checking switch ("lc") minimum clearance . . . . .	(Y Fig. 15)	1/64 inch
13. Trip latch checking switch ("lc") contacts just make when the gap between the trip latch and the stop pin is . . . . .	(W Fig. 15)	1/16 inch
14. Trip coil plunger free travel minimum. . . . .	(S Fig. 13)	1/8 inch
15. Closing coil plunger free travel minimum. . . . .	(F Fig. 15)	1/8 inch
16. Anti-condensation heater . . . . .		functioning continuously

the cylinder are properly lubricated. (Refer to OPERATION AND MAINTENANCE.)

- F. Operate the breaker slowly with the manual charging wrench and note that there is no excessive binding or friction and that the breaker can be moved to the fully opened and fully closed positions.
- G. Operate the mechanism electrically and check the following points:
  - a. Closing, opening, reclosing and trip-free times.
  - b. Minimum trip and closing voltage.
- H. See that all points where the surface of the paint has been damaged during installation are repainted immediately.
- I. Make a final check that the breaker is securely fastened to its foundation and properly leveled.

- J. Check that the ground connections are properly made and tightened.
- K. Make certain that all pipe plugs and bolted connections are properly tightened and that all covers and gaskets are properly installed to prevent entrance of moisture.
- L. Reset the 69 switch if remote tripping is used.

Nominal Voltage	Closing Range		Tripping Range	
	Mini-imum	Maxi-mum	Mini-imum	Maxi-mum
48v d-c	36 -	52v d-c	28 -	60v d-c
125v d-c	90 -	130v d-c	70 -	140v d-c
250v d-c	180 -	260v d-c	140 -	280v d-c
115v a-c	95 -	125v a-c	95 -	125v a-c
230v a-c	190 -	250v a-c	190 -	250v a-c

**CONTROL POWER CHECK**

After the mechanism has been closed and opened slowly several times with the maintenance closing wrench and the mechanism adjustments are checked as described, the closed circuit operating voltages should be checked at the release coil, trip coil, and motor terminals. For electrical operation of the mechanism, the control power may be either an alternating or direct current source. The operating ranges for the closing and tripping voltages are given on the breaker nameplate. The following ranges are standard:

If the closed circuit voltage at the terminals of the coil or motor does not fall in the specified range, check the voltage at the source of power and line drop between the power source and breaker.

When two or more breakers operating from the same control power source are required to close simultaneously, the closed circuit voltage at the closing coil or motor of each breaker must fall within the specified limits.

Electrical closing or opening is accomplished by energizing the closing or trip coil circuit. It is also possible to trip or close the breaker manually by pressing the manual trip lever (19), Fig. 2, or the manual close button (24).

The ML-14 operating mechanism is of the stored-energy type designed to give high speed closing and opening. The mechanism will operate on a-c or d-c voltage. The operating voltage is indicated on the breaker nameplate. Closing and opening operations are controlled electrically by the remote relaying, and mechanically by the manual close and trip levers located behind the front door of the mechanism house.

**SPRING CHARGING**

The mechanism consists of a high speed gear motor (11), Fig. 2, that compresses a set of closing springs (12), and (28), through the action of a simple eccentric (25), a ratchet wheel (22), and pawl (4), Fig. 5, assembly. The rotary action of the motor is converted to a short straight stroke pumping action through the eccentric and a driving link (8), Fig. 5, that carries a spring-loaded driving pawl (4), Fig. 5.

The driving pawl (4), Fig. 5, advances the ratchet wheel (17), Fig. 3, only a few degrees each stroke where it is held in position by the latching and safety pawls (16), Fig. 3. When the ratchet wheel has been rotated approximately 180 degrees the closing springs (11) and (22), Fig. 3, will be fully compressed. As the ratchet wheel continues to rotate, the spring load will shift overcenter and attempt to discharge, but will be prevented from discharging by the closing latch (8), Fig. 9. After only a few degrees of rotation, the closing latch roller (29), Fig. 9, will engage the closing latch (8), Fig. 9, and the compressed springs will be held in repose until a closing operation is required. During the last few degrees of the ratchet wheel rotation the motor limit switches (17), Fig. 4, are released and the driving pawl (4), Fig. 5, is raised from the ratchet wheel surface. This allows the motor and driving mechanism to coast to a natural stop expending all residual energy.

During the time the springs are being compressed the cutoff and anti-pump relay 52Y (22), Fig. 4, locks the closing power circuits open. The 52Y relay will

**OPERATION**

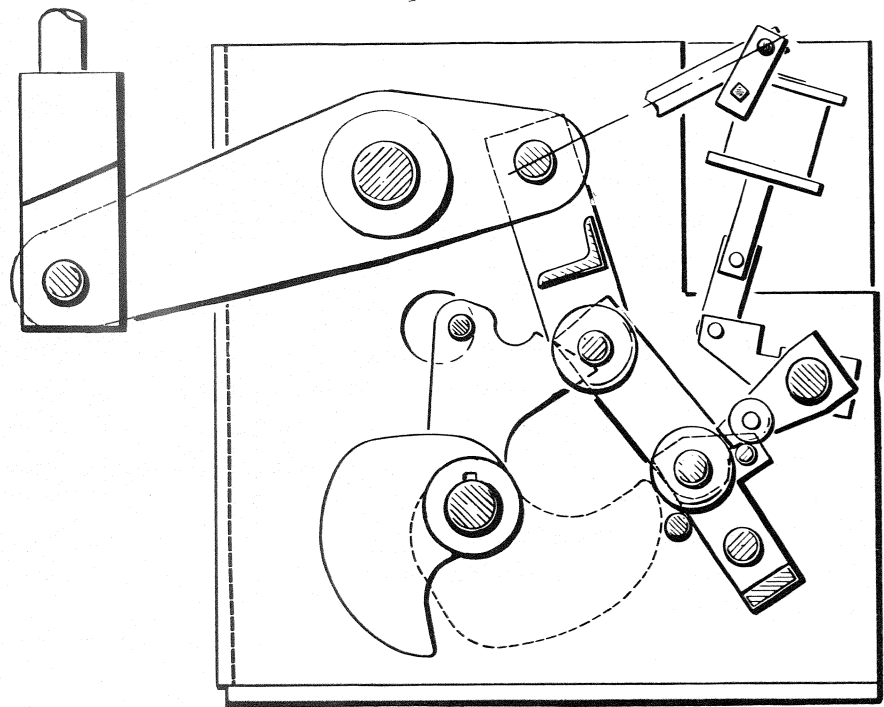


Fig. 16 Position of Linkage - Mechanism Closed  
Undotted cam indicates closing spring charged.  
Dotted cam indicates closing spring discharged.

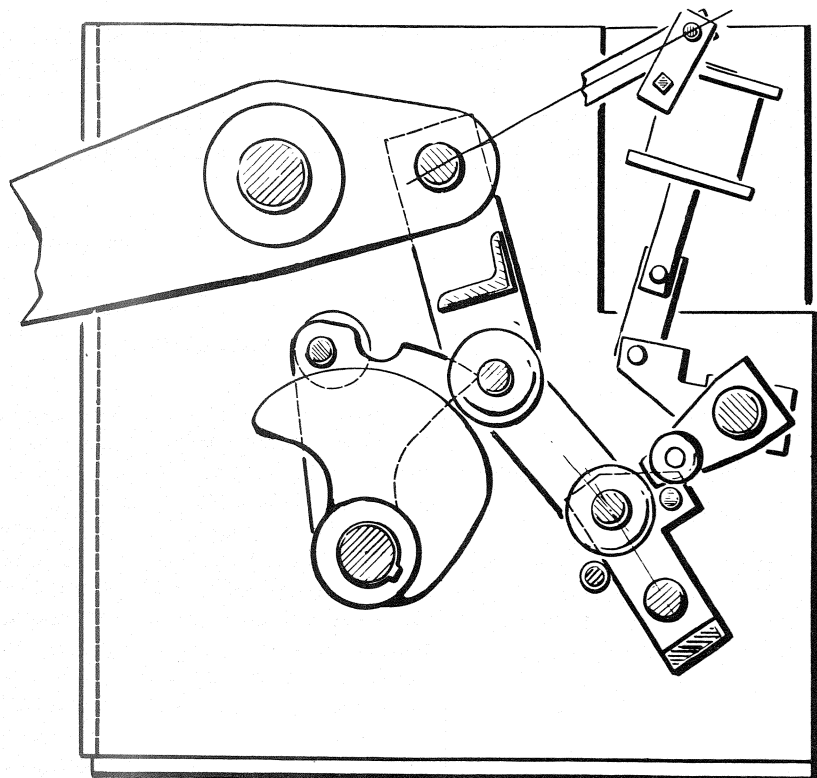


Fig. 17 Position of Linkage - Mechanism Going Closed

Fig. 16 (0832D0149 Sheet 4, View X Rev. 1)

Fig. 17 (0832D0149 Sheet 5, View XIII Rev. 2)

Fig. 18 (0832D0149 Sheet 5, View XII Rev. 2)

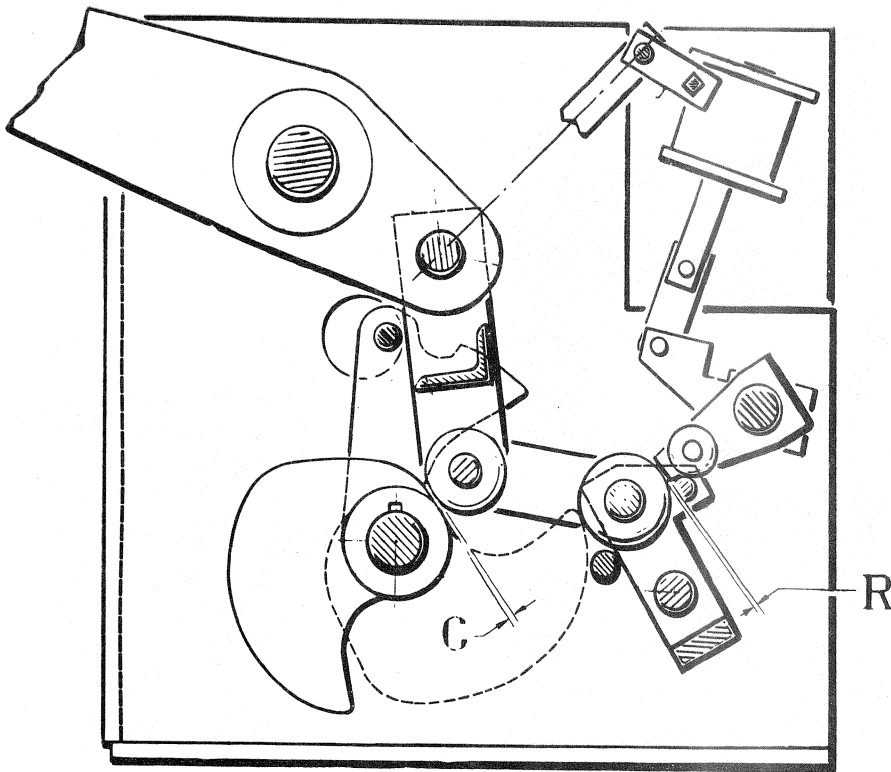


Fig. 18 Position of Linkage - Mechanism Open  
Undotted cam indicates closing spring charged.  
Dotted cam indicates closing spring discharged.

Fig. 19 (0832D0149 Sheet 4, View XI Rev. 1)

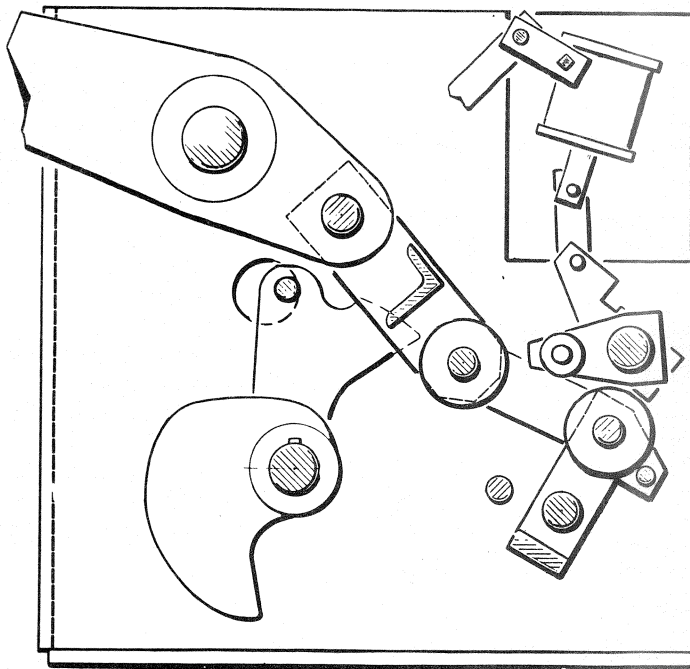


Fig. 19 Position of Linkage - Mechanism Going Open

remain energized until the springs are fully charged and the control and motor limit switch (17), Fig. 4, contacts are reset.

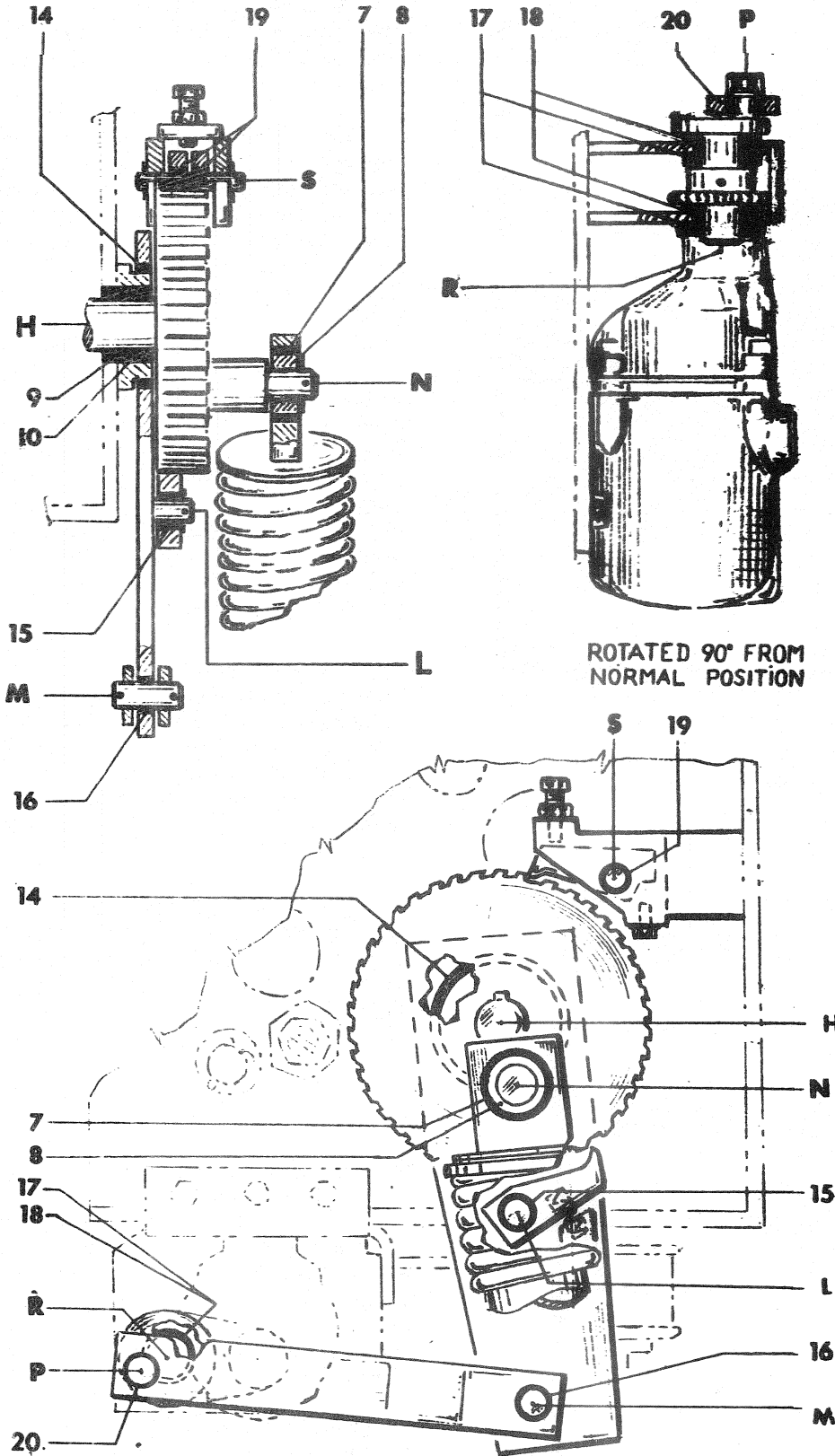
The closing springs may be charged manually if control voltage is lost. A standard 5/8 inch ratchet wrench should be used to rotate the eccentric in a counterclockwise direction until the indicator reads "CHARGED" and the driving pawl no longer engages the ratchet wheel. The use of the ratchet wrench provides for maximum safety in the event that control power is suddenly restored without warning. In this event, the motor drive will take over again and continue to charge the springs while the ratchet wrench harmlessly turns in the unloaded direction. Removing the fused pullouts (4), Fig. 4, will prevent the power from being applied when it is not required.

#### CLOSING OPERATION

Closing the breaker is accomplished by energizing the closing coil (20), Fig. 3, or by manually pressing the close button (24), Fig. 2. In either case, the closing latch (8), Fig. 9, is rotated away from the closing latch roller (29), Fig. 9, permitting the springs to discharge. The energy of the springs is applied to the rotation of a cam (39), Fig. 10, which closes the breaker through a simple linkage that remains trip free at all times. A monitoring switch (3), Fig. 6, operated by the closing latch (8), Fig. 9, will start the spring-charging motor (34), Fig. 9, after it is fully reset.

When the breaker is closed without power to the spring or charging motor, the cam (39), Fig. 10, is in the position of the dotted cam shown in Fig. 16. This is due to the motor not forcing the cam into the undotted cam position shown in Fig. 16 since the motor did not start charging the springs immediately upon closing the breaker as it does during a normal closing operation when the motor is energized.

**DO NOT OPERATE THE MANUAL CLOSE BUTTON WHEN THE BREAKER IS CLOSED.** If the button is pushed, the energy stored in the springs will be dissipated against the stop pin



1. Output Crank Bushing
2. Output Crank Main Shaft Bushing
3. Upper Link Bushing
4. Lower Link Bushing
5. Trip Latch Roller Bushing
6. Trip Latch Shaft Bearing
7. Guide Block Bearing (Outer Race)
8. Guide Block Bearing (Inner Race)
9. Cam Shaft Bearing (Outer Race)
10. Cam Shaft Bearing (Inner Race)
11. Closing Prop Bushing
12. Link Shaft Bushing
13. Closing Latch Shaft Bearing
14. Driving Crank Bushing
15. Driving Pawl Bushing
16. Driving Link Bushing
17. Driving Eccentric Shaft Bearing (Outer Race)
18. Driving Eccentric Shaft Bearing (Inner Race)
19. Latching and Safety Pawl Bushing
20. Driving Eccentric Bushing
21. Trip Latch Roller Bearing (Inner Race)
22. Trip Latch Roller Bearing (Outer Race)
23. Cam Follower Roller Bearing (Inner Race)
24. Cam Follower Roller Bearing (Outer Race)

Fig. 20A (0958D0958 View III Rev. 1)

NOTE: When replacing bronze bushings in the linkage frequently the bushings will require reaming to permit free rotation on their pins or shafts. Measure the diameter of the shaft and ream the bushing 0.001 to 0.003 inch larger than the shaft after it is inserted into place, e.g., the driving link bushing (16), Fig. 20, should be reamed to 0.748 to 0.750 inch since the shaft measures 0.746 to 0.747 inch.

Fig. 20A Bushing and Bearing Location in Mechanism



(21), Fig. 9, and the links (41), Fig. 10, causing bending of the pin and indentations on the links. When closing the breaker the energy in the springs is used and the stop pin or links are not damaged.

### OPENING OPERATION

An electrical opening operation is initiated by energizing the trip coil (15), Fig. 2. This is accomplished either by actuating a remote trip circuit or by a combination of relays and current devices used to detect a fault on the load side of the breaker. When energizing the trip coil, the trip plunger rotates the trip latch (6), Fig. 2, causing the operating mechanism linkage to collapse. The energy stored in the breaker opening springs is thus released, opening the breaker. During this operation, the trip coil circuit is de-energized, and upon completion of

the opening operation, the operating mechanism is returned to its normal position, ready for closing.

Manual tripping follows the same procedure except that instead of energizing the trip circuit, the manual tripl lever (19), Fig. 2, is used. If the control house is closed pushing the manual trip push button (21), Fig. 2, on the surface of the front door will trip the breaker. The mechanism cannot be operated slowly while opening.

When the breaker is opened after being closed without charging the closing springs, the cam (39), Fig. 10, is in the position of the dotted cam shown in Fig. 18. This is due to the motor not forcing the cam into the undotted position shown in Fig. 18 since the motor did not start charging the closing springs immediately upon closing the breaker as

it does during a normal closing operation when the motor is energized.

### TRIP-FREE OPERATION

When testing the breaker the trip-free operation should be made by using the breaker contacts to energize the trip-free circuitry. This more closely simulates a breaker closing against a fault.

If the trip coil is energized while the breaker is closing, the trip coil plunger (3), Fig. 7, will force the trip latch (6), Fig. 2, away from the trip roller (20), Fig. 2, causing the mechanism linkage to collapse and the breaker to reopen. The closing cam (39), Fig. 10, will complete its closing stroke and the springs will recharge as in a normal closing operation. The position of the mechanism linkage during its operation is shown in Figures 16, 17 and 18.

## MAINTENANCE

### PERIODIC INSPECTION

The operating mechanism of an oil circuit breaker is a very important part and must have regular systematic inspection during which every part is looked over carefully. The frequency of inspections should be determined by each operating company on the basis of the service to which the operating mechanism is subjected. Operating experience will soon establish a maintenance schedule that will give assurance of proper mechanism condition. An annual inspection and maintenance program is desirable in addition to a visual inspection at more frequent intervals. These inspections should be co-ordinated with an inspection of the breaker parts for maximum convenience.

### PRECAUTIONS

1. Be sure that all primary and secondary circuits have been opened and grounded before any inspection or maintenance is attempted.
2. After any adjustment is made in the mechanism, operate manually to check the adjustment before operating electrically.

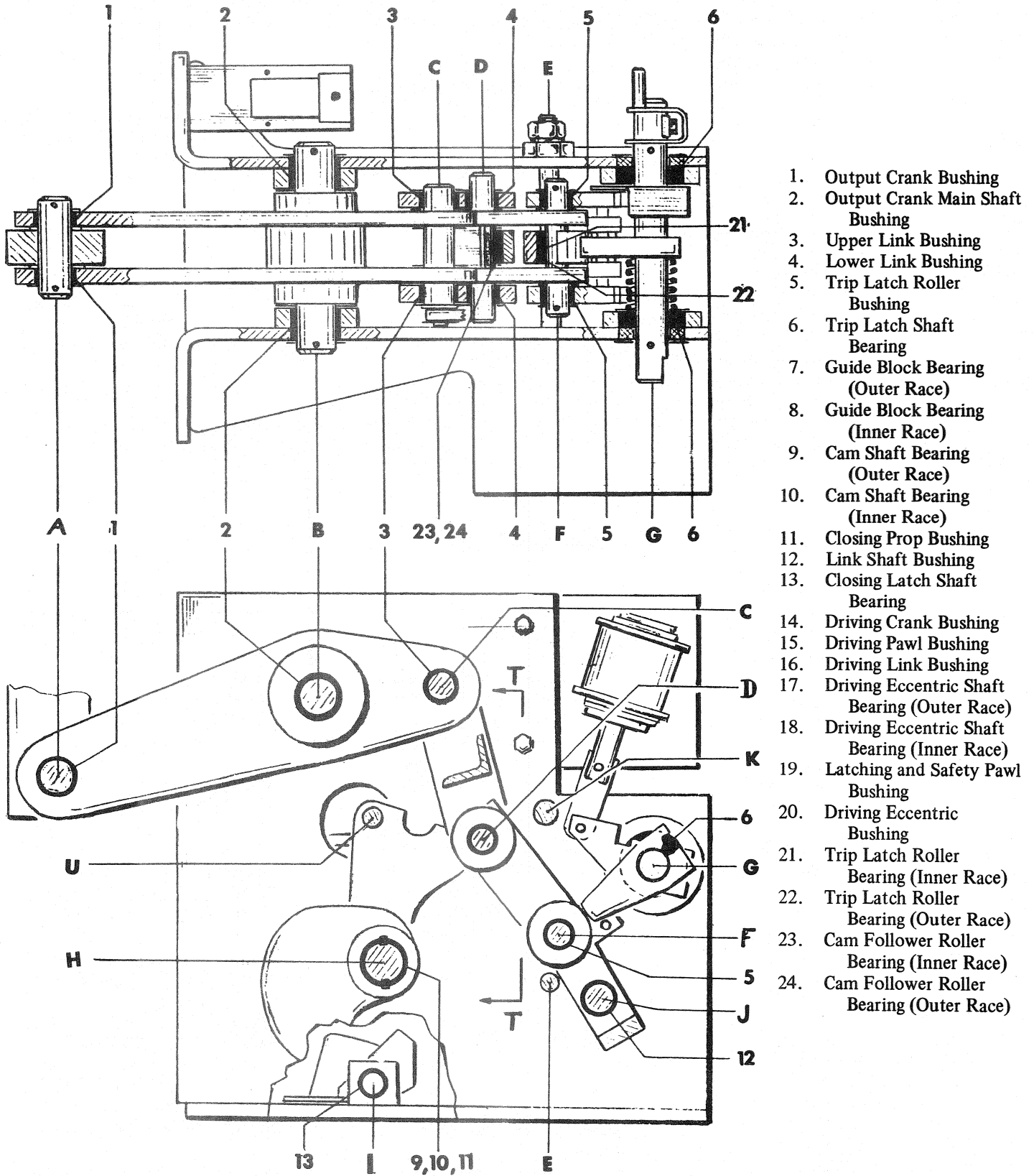
3. Use the connection diagram accompanying the operating mechanism in all cases when testing and connecting the mechanism.
4. When making adjustments in the mechanism or breaker make certain that the closing springs are blocked as described under **MANUAL CLOSING**.

**DO NOT WORK ON THE BREAKER OR MECHANISM WHILE IN THE CLOSED POSITION UNLESS THE PROP AND TRIP LATCH HAVE BEEN SECURELY WIRED OR BLOCKED TO PREVENT ACCIDENTAL TRIPPING. DO NOT WORK ON THE BREAKER OR MECHANISM WHILE THE SPRINGS ARE CHARGED UNLESS THEY ARE SECURED IN THAT POSITION BY THE MAINTENANCE SPRING BLOCKING DEVICE.**

5. **DO NOT OPERATE THE MANUAL CLOSE BUTTON WHEN THE BREAKER IS IN THE CLOSED POSITION.**

- A. Output crank to breaker vertical operating rod shaft
- B. Output crank main shaft
- C. Linkage to output crank shaft
- D. Cam follower roller shaft
- E. Trip latch clearance adjustment eccentric shaft
- F. Trip latch roller shaft
- G. Trip latch shaft
- H. Cam shaft
- I. Closing latch shaft
- J. Link shaft
- K. Stop pin
- L. Driving pawl pin
- M. Driving link pin
- N. Guide block pin (right side)
- O. Guide block pin (left side)
- P. Driving eccentric shaft
- R. Driving eccentric to sprocket shaft
- S. Latching and safety shaft
- U. Prop spacer and reset spring pin

Shaft and Pin Identification for Fig. 20A



1. Output Crank Bushing
2. Output Crank Main Shaft Bushing
3. Upper Link Bushing
4. Lower Link Bushing
5. Trip Latch Roller Bushing
6. Trip Latch Shaft Bearing
7. Guide Block Bearing (Outer Race)
8. Guide Block Bearing (Inner Race)
9. Cam Shaft Bearing (Outer Race)
10. Cam Shaft Bearing (Inner Race)
11. Closing Prop Bushing
12. Link Shaft Bushing
13. Closing Latch Shaft Bearing
14. Driving Crank Bushing
15. Driving Pawl Bushing
16. Driving Link Bushing
17. Driving Eccentric Shaft Bearing (Outer Race)
18. Driving Eccentric Shaft Bearing (Inner Race)
19. Latching and Safety Pawl Bushing
20. Driving Eccentric Bushing
21. Trip Latch Roller Bearing (Inner Race)
22. Trip Latch Roller Bearing (Outer Race)
23. Cam Follower Roller Bearing (Inner Race)
24. Cam Follower Roller Bearing (Outer Race)

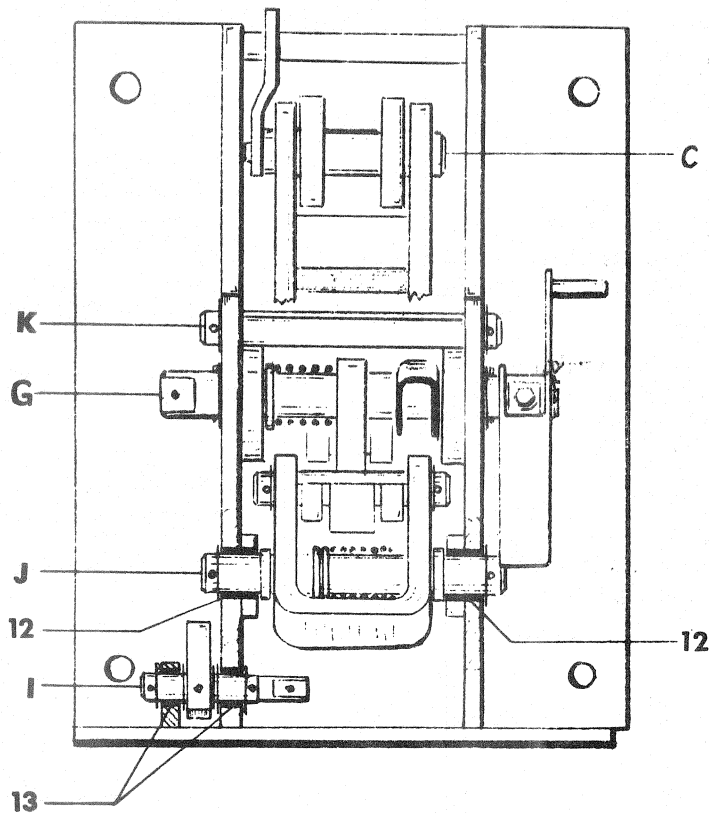
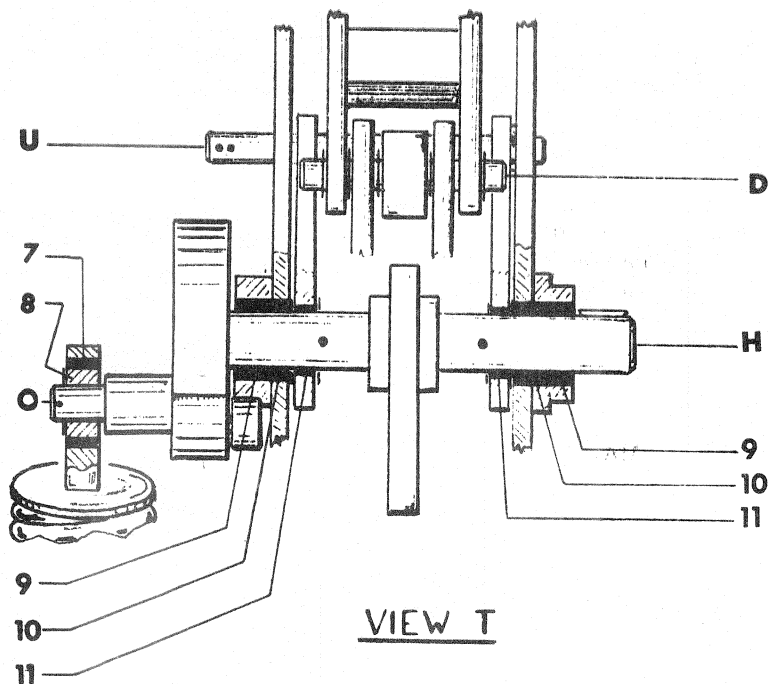
Fig. 20B (0958D0958 View I Rev. 1)

Fig. 20B Bushing and Bearing Location in Mechanism

Fig. 20C (0958D0958 View II and View T Rev. 1)

- A. Output crank to breaker vertical operating rod shaft
- B. Output crank main shaft
- C. Linkage to output crank shaft
- D. Cam follower roller shaft
- E. Trip latch clearance adjustment eccentric shaft
- F. Trip latch roller shaft
- G. Trip latch shaft
- H. Cam shaft
- I. Closing latch shaft
- J. Link shaft
- K. Stop pin
- L. Driving pawl pin
- M. Driving link pin
- N. Guide block pin (right side)
- O. Guide block pin (left side)
- P. Driving eccentric shaft
- R. Driving eccentric to sprocket shaft
- S. Latching and safety shaft
- U. Prop spacer and reset spring pin

Shaft and Pin Identification



NOTE: When replacing bronze bushings in the linkage frequently the bushings will require reaming to permit free rotation on their pins or shafts. Measure the diameter of the shaft and ream the bushing 0.001 to 0.003 inch larger than the shaft after it is inserted into place, e.g., the driving link bushing (16), Fig. 20, should be reamed to 0.748 to 0.750 inch since the shaft measures 0.746 to 0.747 inch.

Fig. 20C. Bushing and Bearing Location in Mechanism

A careful inspection should be made to check for loose nuts or bolts and broken retaining rings. All cam, roller, and latch surfaces should be inspected for any evidence of damage or excessive wear. Lubricate the mechanism as outlined below, then, using the manual charging wrench, open and close the breaker several times to make certain that the mechanism operates freely throughout its entire stroke. Check the mechanism adjustments as specified under ADJUSTMENTS. Check all terminal connections.

#### OPTIONAL MAINTENANCE JACKING DEVICE

The jacking device consists of two rods that attach to the pin securing the vertical operating rod coupling (36), Fig. 10, and support a platform for a hydraulic jack.

Before installing rods and platform remove the breaker from service, disconnect the motor and control power, and discharge the closing springs by closing the breaker or install the spring blocking device. To install the jacking device, open the breaker and attach the rods and platform to the operating rod pin and contain with a washer and cotter pin. Put the jack on the platform with shims underneath to remove clearance between the top of the jack and the frame.

The breaker may now be jacked closed. The closed position is reached when the props (19), Fig. 10, fall under pin (68).

To slowly open the breaker, hold the manual trip lever in initially and allow the jack to slowly collapse by using the release valve on the jack.

**CAUTION: DO NOT ATTEMPT TO OPERATE THE BREAKER WITH THIS DEVICE WHILE THE BREAKER IS ENERGIZED.**

Remove the jack, rods and platform before returning the breaker to normal operation.

#### INSULATION TEST

If the breaker secondary wiring is to be given a hi-potential test at 1500 volts a-c, remove both the motor leads from

the terminal boards. Failure to disconnect the motor from the circuit may cause damage to the winding insulation.

#### LUBRICATION

In order to maintain reliable operation, it is important that all mechanisms be properly lubricated at all times. Most of the bearings and rolling surfaces utilize a new type of dry lubrication that will require no maintenance and will last the life of the equipment. Only a few bearings and surfaces listed in the chart, Fig. 20, require lubrication. These have been properly lubricated during assembly at the factory using the finest grades of lubricants available. However, even the finest oils and greases have a tendency to oxidize with age, as evidenced by hardening and darkening in color. Elimination of the hardened lubricant is essential for the proper operation of circuit breakers. Also, frequent operation of the mechanism causes the lubricant to be forced out from between the bearing surfaces. A simple lubrication will often clear up minor disturbances which might be mistaken for more serious trouble.

A definite lubrication schedule should be set up taking into consideration the frequency of operation of the mechanism and local conditions. Until such a schedule is worked out, the mechanism should be lubricated at each periodic inspection and also whenever it is overhauled, in accordance with the lubrication chart. It is also recommended that all circuit breakers and their associated operating mechanisms be operated at regular intervals to insure the user that the equipment is operating freely.

The lubrication chart is divided into two methods of lubrication. The first method outlines the maintenance lubrication which should be performed at the time of periodic maintenance, and requires no disassembly. The second method outlines a lubrication procedure similar to that performed on the breaker at the factory, but should be used only in case of a general overhaul or disassembly for other reasons, or if the operation of the breaker becomes slower.

General Electric Lubricant D50H15 is available in four-ounce collapsible tubes, order as 6591901P1. It is so

packaged to insure cleanliness and to prevent oxidation.

#### METHOD OF CLEANING BEARINGS

Whenever cleaning is required, as indicated in the lubrication chart, the following procedures are recommended.

#### SLEEVE BEARINGS

Some of the sleeve bearings used throughout the linkage are Textolite; others are bronze. If contaminants are present they should be removed by immersing the link and bearing in clean petroleum solvent or similar cleaner and using a stiff brush. Do not remove the bearings from the links. **DO NOT USE CARBON TETRACHLORIDE** since it may be injurious to the user.

All of the sleeve bearings, for example, the bearings of the main shaft (2), Fig. 20, and the bearing of the driving link (16), should be cleaned and lubricated with G-E D50H15 lubricant at general overhaul periods.

#### ROLLER AND NEEDLE BEARINGS

All the roller and needle bearings, for example, the cam follower bearings (23 and 24), Fig. 20, trip latch roller bearing (21 and 22) and the cam shaft bearings (9 and 10) should be first removed from the mechanism and the inner race disassembled. They should then be placed in a container of clean petroleum solvent or similar cleaner. **DO NOT USE CARBON TETRACHLORIDE**. If the grease in the bearings has become badly oxidized, it may be necessary to use alcohol (the type used for thinning shellac) to remove it. Ordinarily, by agitating the bearings in the cleaning solution, and using a stiff brush to remove the solid particles, the bearings can be satisfactorily cleaned. Do not handle the bearings with bare hands as deposits from the skin onto the bearings are inductive to corrosion. If the bearings are touched, the contamination can be removed by washing in alcohol. After the bearings have been thoroughly cleaned, spin them in clean new light machine oil until the cleaner or solvent is entirely removed. Allow this oil to drain off and then repack the bearings immediately with G-E lubricant D50H15 being sure all metal parts are greased. Any removable seals should then be replaced.

PART	LUBRICATION AT MAINTENANCE PERIOD	ALTERNATE LUBRICATION (REQUIRES DISASSEMBLY)
Sleeve Bearings - Textolite Bearings -	No lubrication required.	Film of D 50H15 grease.
Sleeve Bearings - Bronze Bearings -	Light application of machine oil SAE 20 or SAE 30.	Remove bearings or links, clean per instructions and apply D 50H15 grease liberally.
Roller and Needle Bearings -	Light application of machine oil SAE 20 or SAE 30.	Clean per instructions and repack with D 50H15 grease.
Ground surfaces such as cams, ratchet teeth, etc. (Surfaces coated with $MoS_2$ )	No lubrication required except a light film of D 50H15 grease.	No lubrication required except a light film of D 50H15 grease.
Ground surfaces such as latches, rollers, prop, etc.	Wipe clean and apply D 50H15 grease.	Wipe clean and apply D 50H15 grease.
Sealed Bearings - trip latch roller shaft	Cannot be relubricated.	Replace when they become sluggish.
Motor Gear Box	No lubrication normally required. Lubricate when motor becomes sluggish.	Wipe clean and apply Texaco "All-Temp" or a similar lubricant.

## LUBRICATION CHART

NOTE: If it becomes necessary to clean the bearings in alcohol (shellac thinner), be sure the alcohol is perfectly clean, and do not allow the bearings to remain in the alcohol more than a few hours. If it is desirable to leave the bearings in the alcohol for a longer time, an inhibited alcohol such as is used for anti-freeze should be used. Even then the bearings should be removed from the alcohol within twenty-four hours. Esso Anti-Freeze and Du Pont Zerone are satisfactory for this purpose. Precautions against the toxic effects of the alcohol must be exercised by wearing rubber gloves and by using the alcohol in a well ventilated room; excessive exposure to the fumes can be unpleasant

to personnel. Washing the bearings in the light oil and draining should follow immediately, then apply the lubricant.

Bearings that are pressed into the frame or other members such as the eccentric drive bearings contained in the motor support (9), Fig. 5, should not be removed. After removing the shaft and inner race the bearing can usually be cleaned satisfactorily with petroleum solvent or a similar cleaner and a stiff brush. Follow the procedure outlined above using a light machine oil and G-E lubricant D50H15 before reassembling the inner race and shaft.

## ROLLING SURFACES

A number of rolling and rubbing surfaces in the mechanism have been lubricated with a baked-on, dry, molybdenum disulfide coating. This requires

no maintenance and should last the life of the breaker.

## TROUBLE SHOOTING

Failure of a mechanism to operate properly will generally fall within three general classes; failure to trip, failure to close or latch closed, and failure of closing springs to recharge. The following is a brief outline showing particular types of problems that might be encountered, together with suggestions for remedying the trouble:

## FAILURE TO TRIP

1. Mechanism binding or sticking caused by lack of lubrication.  
REMEDY: Lubricate complete mechanism.
2. Mechanism binding or sticking caused by being out of adjustment.

**REMEDY:** Check all mechanism adjustments, latches, stops, auxiliary devices, etc., in accordance with section on ADJUSTMENTS. Examine latch and roller surfaces for corrosion. Clean as necessary.

3. Damaged trip coil.  
**REMEDY:** Replace damaged coil after determining reason for the failure.
4. Blown fuse in trip circuit.  
**REMEDY:** Replace blown fuse after determining cause of failure.
5. Faulty connections in trip circuit.  
**REMEDY:** Repair broken or loose wires and see that all binding screws are tight.
6. Damaged or dirty contacts in trip circuit.  
**REMEDY:** Recondition or replace contacts.

#### FAILURE TO CLOSE OR LATCH CLOSED

1. Mechanism binding or sticking caused by lack of lubrication.  
**REMEDY:** Lubricate complete mechanism.
2. Damaged or dirty contacts in control circuit.  
**REMEDY:** Recondition or replace contacts.
3. Blown fuse in closing circuit.  
**REMEDY:** Replace blown fuse after determining cause of failure.
4. Faulty connection in charging circuit.  
**REMEDY:** Repair broken or loose wires and see that all binding screws are tight.
5. Failure to latch closed.
  - A. Bend spring (57), Fig. 10, to increase its tension and make certain it is not bind-

ing against the sides of the trip latch assembly support link (55), Fig. 10.

- B. Check to see if the manual close button has clearance between its shaft and the closing latch monitoring switch operating lever (12), Fig. 10.
- C. If this does not cure the problem, remove the trip latch (50), Fig. 10, and turn it over 180 degrees; then replace. This is an on-center latch and is occasionally ground slightly off center. Make certain the breaker will trip at minimum voltage.

#### FAILURE OF CLOSING SPRINGS TO RECHARGE

1. Driving motor inoperative due to lack of power.  
**REMEDY:** Check and replace fuses after determining cause of blown fuses.
2. Driving motor inoperative due to an opened or shorted winding.  
**REMEDY:** Replace motor after checking motor limit switches for proper setting and ratchet wheel and linkage for possible foreign objects causing jamming.
3. Driving motor continues to run but does not completely charge springs.  
**REMEDY:** Recheck the pawl clearance "P" and "Q" and readjust as necessary. Move the motor-mount assembly in increments of 1/64 inch.

#### REPAIR AND REPLACEMENT

The following information covers in detail the proper method of removing various parts of the mechanism in order to make any necessary repairs. This section includes only those repairs that

can be made at the installation on parts of the mechanism that are most subject to damage or wear. **IMPORTANT: UPON COMPLETION OF ANY REPAIR WORK, ALL MECHANISM ADJUSTMENTS MUST BE CHECKED.** Refer to the section on **INSTALLATION**, paying particular attention to **ADJUSTMENTS** and **FINAL INSPECTION**.

#### TRIP LATCH CHECKING SWITCH

To remove the trip latch checking switch (4), Fig. 7, remove the two mounting screws and disconnect the lead wires. Reassemble in the reverse order and check the switch adjustments as explained under **ADJUSTMENTS**.

#### MOTOR LIMIT SWITCHES

The three switches (11), Fig. 8A and 8B are mounted in tandem.

1. Remove the opening spring per the instructions below.
2. Remove the two mounting bolts (28), Fig. 9, from the switch support (16), Fig. 4.
3. Remove the two mounting screws of the lower switch.
4. Remove the two mounting screws of the center switch.
5. Remove the two mounting screws of the upper switch.
6. Disconnect the lead wires of the switch which is to be replaced.
7. Reassemble in the reverse order and check the switch adjustment as explained under **ADJUSTMENTS**.

#### TRIP SHAFT AND LATCH

1. Remove the trip latch checking switch operating lever (5), Fig. 7.
2. Remove the cotter pins (6), Fig. 7, on both ends of the shaft.
3. Remove the set screw (19), Fig. 7, which is in the latch shaft (18), Fig. 7.

4. Remove the trip crank adjustment bolt (16), Fig. 7.
5. Place a block between the latch and the frame (either side) and drive the shaft until the latch is free of the key.
6. Remove the key and all burrs that may be raised around the keyway on the shaft. Burrs will scar the bearing surfaces if they are not removed.
7. Reassemble the parts in the reverse order. Be sure the trip latch spring (47), Fig. 11, is properly installed and the trip latch (50), Fig. 11, is aligned in the center of the trip latch roller (52), Fig. 11. Check the trip latch adjustment as described under ADJUSTMENTS.

#### TRIP LATCH ROLLER BEARING

1. Remove the two cotter pins at the ends of the shaft (54), Fig. 10.
2. Partially remove the shaft out the right side of the frame (2), Fig. 9, until the trip latch roller (52), Fig. 10, is free.
3. Reassemble in the reverse order with the proper spacing of washers. Be sure the trip latch roller (52), Fig. 10, rotates freely.

#### TRIP COIL (TC)

Refer to Fig. 7. To replace the potential trip coil (11), proceed as follows:

1. With the breaker in the open position, remove the two mounting bolts which support the coil support bracket (9).
2. Remove the upper portion of the support bracket (9), and remove the shims (10) and (12).
3. Cut the trip coil wires at the butt connectors and remove the trip coil (11).

4. When replacing the trip coil be sure to assemble the correct fiber spacers at the ends before securing the support bracket (9).
5. Adjust the trip coil location to allow 7/32 to 9/32 inch of trip coil plunger (3), before the trip latch (7), starts to move.
6. Butt connect the wires and check the operation of the trip coil electrically and mechanically.

#### CLOSING COIL (CC)

To remove the closing coil (20), Fig. 3, proceed as follows:

1. Block the closing springs (11) and (22), Fig. 3, as described under INSTALLATION.
2. Remove the left-hand closing spring (12), Fig. 2, as described in CLOSING SPRINGS.
3. Remove the two mounting bolts which fasten the closing coil (20), Fig. 3, support bracket to the mechanism frame (2), Fig. 9, and remove the shims above and below the closing coil.
4. Cut the closing coil wires at the butt connectors and remove the closing coil.
5. Replace the closing coil and the correct number of fiber spacers before fastening the support bracket to the mechanism frame.
6. Butt connect the wires and check that the closing coil plunger (15), Fig. 9, is not binding. Check the closing coil for electrical operation.

#### CLOSING LATCH

1. Remove the cotter pins at both ends of the closing latch shaft (5), Fig. 8A.
2. Remove the closing latch spring (17), Fig. 9, and the closing latch monitoring switch opera-

ting level (12), Fig. 11.

3. Remove the set screws from the closing latch (6), Fig. 8A.
4. Move the closing latch shaft (5), Fig. 8A, to the left (away from the frame) by tapping lightly on the inside end of the shaft. Rotate the shaft and continue tapping until the shaft is free. The shaft will push the outside needle bearing from its housing.
5. Reassemble in the reverse order putting the bearing into the frame last. Use a small piece of tubing or pipe when inserting the bearing to assure proper alignment of the bearing with its hole.
6. Check the latch adjustments as described under ADJUSTMENTS.

#### MOTOR SUPPORT

1. To remove the motor support (9), Fig. 5, first remove the closing latch spring (17), Fig. 9.
2. Remove the retaining ring which prevents the driving link (7) Fig. 6, from falling off the manual charging stud (6), Fig. 6.
3. Remove the driving link (7), Fig. 6.
4. Remove the motor leads from the terminal board (12), Fig. 8A.
5. Remove the six 3/8 inch bolts (32), Fig. 11, from the bottom of the frame (2), Fig. 9.
6. Remove the four mounting bolts from the motor (not shown).
7. Remove the retaining ring from between the motor (2), Fig. 5, and the motor support (9), Fig. 5.
8. Remove the motor (2), Fig. 5.
9. Reassemble all parts of the motor support in the reverse

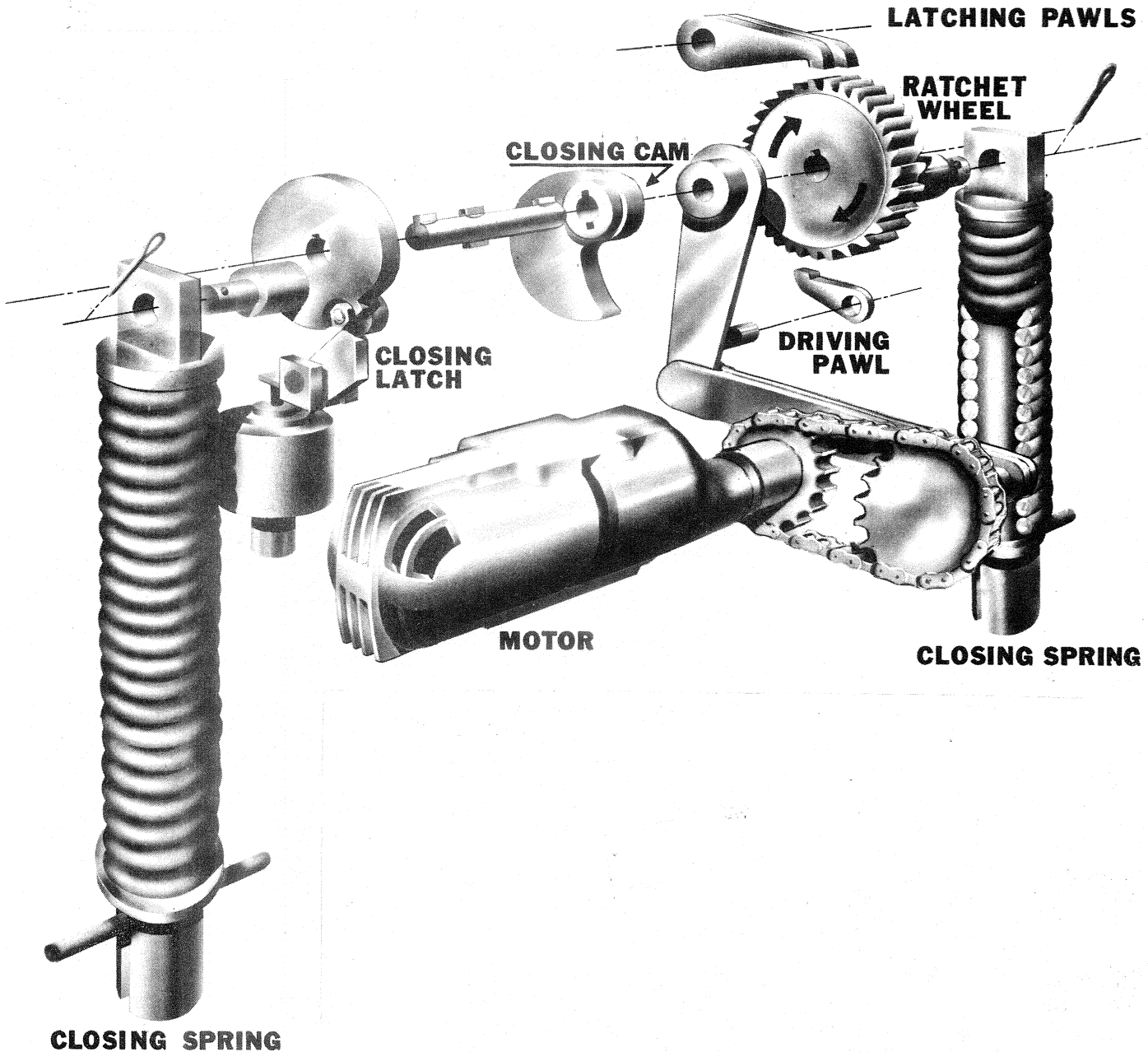


Fig. 21 (8915797)

Fig. 21. Schematic of ML-14 Mechanism

order and re-align it properly as described under DRIVING PAWL ADJUSTMENTS.

**CAM**

1. Remove the two set screws from the ratchet wheel (17), Fig. 3, and remove the wheel from the main shaft (18), Fig. 3.
2. Remove the two set screws from the cam (2), Fig. 4.
3. Remove the prop reset test spring (10), Fig. 4.
4. Remove the two set screws from the cam (39), Fig. 10, and move the cam to the right on the shaft (3), Fig. 4, as far as it will go. Slide the cam shaft to the left until the key is fully exposed. Remove the key and check the shaft for burrs. Remove any burrs before removing the shaft from the frame.
5. Remove the shaft out the left side of the mechanism frame (2), Fig. 9.
6. Reassemble in the reverse order using the correct number of washers and spacers to properly locate the parts.
7. Rotate the mechanism through a closing operation using the manual charging wrench (7), Fig. 5. Check the location of the cam



Fig. 22 (8915798)

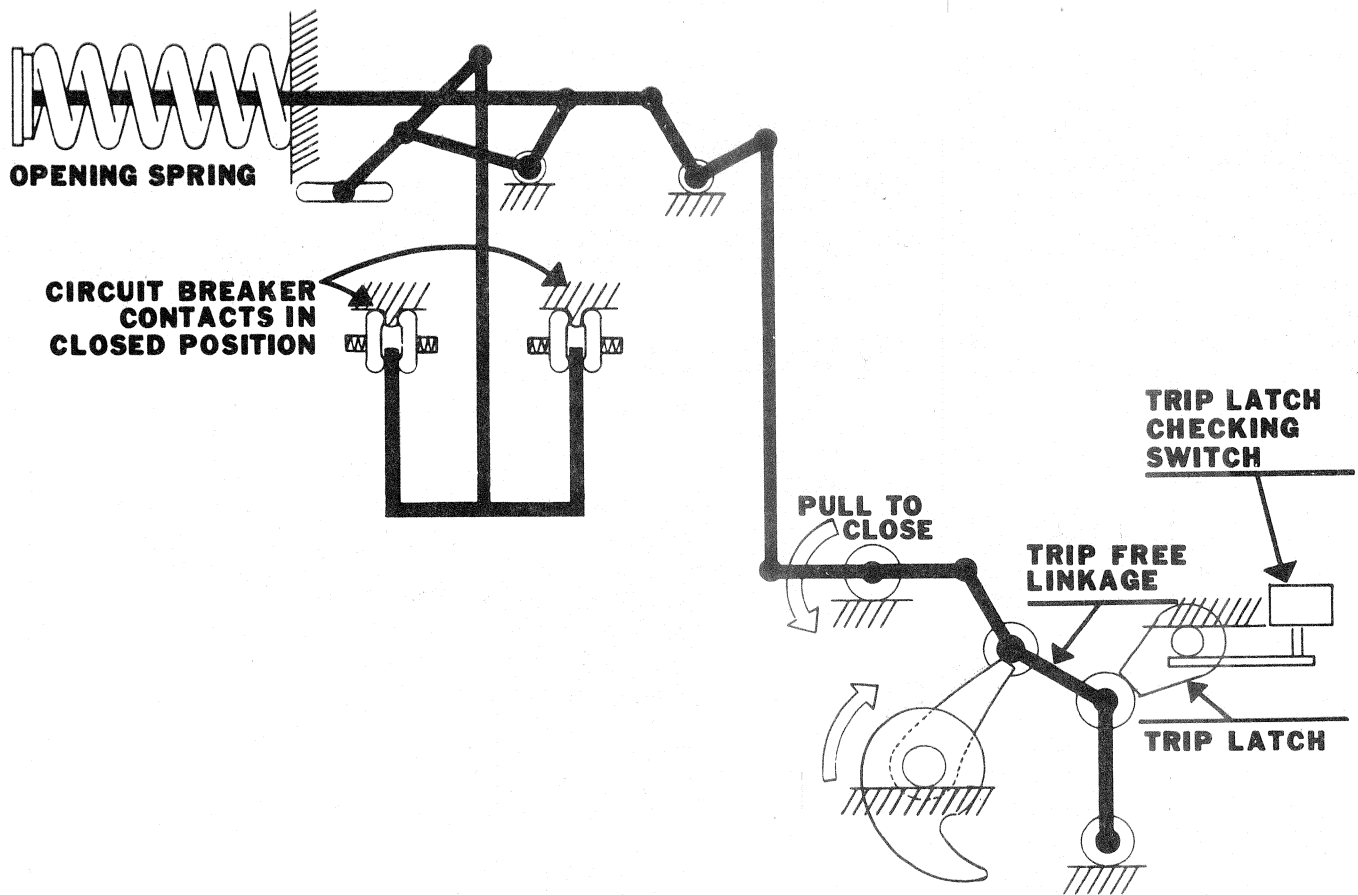


Fig. 22. Schematic of ML-14 Mechanism and Circuit Breaker in Closed Position

follower roller (37), Fig. 10, on the cam (39), Fig. 10. If necessary, adjust the cam on the cam shaft to correct the alignment. Complete the closing operation and check the location of the cam follower roller shaft (68), Fig. 10, on the prop (38). It should be approximately centered.

#### CLOSING SPRINGS

The closing springs (12) and (28), Fig. 2, can be removed as follows:

1. Charge the springs with the manual charging wrench and apply the spring blocking device (13) and (30), Fig. 2, as described in INSTALLATION.

2. Discharge the springs by pushing the manual close button (24), Fig. 2.
3. Rotate the cam shaft (7), Fig. 12, by using the manual charging wrench (7), Fig. 5, until the gap between the springs (12) and (28), Fig. 2, and the guide block (19), Fig. 3 and (8), Fig. 2, is two inches or more.
4. Lift both springs until they clear the lower supports, then pull forward and down until the top supports are free. Removing the left spring (12), Fig. 2, is difficult with the control panel (20), Fig. 4, assembled in the control house (1), Fig. 3. Remove the

retaining cotter pin and washer from the limit switch cam (1), Fig. 8A, shaft. Remove the inner race of the bearing in the guide blocks (3). This permits the guide block (3) to slide off the shaft of the limit switch cam (1) for easy removal of the left spring (12), Fig. 2.

5. Either open the operating mechanism by pushing the manual trip lever or block the breaker in the closed position with a suitable blocking device.
6. After reassembling the springs check the breaker stroke as described in the breaker instruction book.

#### REPLACEMENT PARTS

It is recommended that sufficient renewal parts be carried in stock to enable prompt replacement of worn, broken, or damaged parts. A stock of

such parts minimizes service interruptions caused by breakdowns and saves time and expense. When continuous operation is a primary consideration, more renewal

parts should be carried, the amount depending upon the severity of the service and the time required to secure replacements.

On the following pages a list of replacement parts will be found. This list includes both recommended renewal parts as designated by the asterisk (\*) as well as a listing of parts ordered most frequently. The actual drawing number as well as the figure and part numbers in this book are given. Where parts are required that do not appear on this list, and hence no drawing number is available the instruction book number as well as the figure and part number should be given

on the purchase order.

Replacement parts may not always be identical to the original parts since improvements are made from time to time. The parts which are furnished, however, will be interchangeable. All "O" rings have a limited shelf life of three years.

When ordering replacement parts, address the nearest Sales Office of the

General Electric Company, giving the complete data shown on the breaker nameplate, such as serial number, type, and rating of the breaker. The breaker nameplate is mounted on the inside of the front door of the operating mechanism compartment. Also, furnish a complete description of each part as outlined above, the quantity required and, if possible, the number of the requisition on which the breaker was originally furnished.

FIG. NO.	REF. NO.	CATALOG NO.	QTY. PER MECH.	DESCRIPTION OF PART
2	3	0128B1722G001	1	Auxiliary Switch - SB-1 (11 Stage, 11 Circuit) (Special)
2	3	0226A9901G001	1	Auxiliary Switch - SB12 (5 Stage, 10 Circuit) (Standard)
2	*11	0193A4998P001	1	Spring Charging Motor (48v d-c)
2	*11	0193A4998P002	1	Spring Charging Motor (125v d-c and 115v a-c)
2	*11	0193A4998P003	1	Spring Charging Motor (250v d-c)
2	*11	0193A4998P004	1	Spring Charging Motor (230v a-c)
2	14	0103A3075P001	1	Operation Counter
2	16 & 33	0178V0727P001	2	Window
2	Ø	0183V0711P001	2	Window Gasket
2	Ø	0455A0300P001	1	Operation Counter Return Spring
2	17	0307V0199P001	1	Lock-out Switch (69 Device)
3	17	0104C8078G001	1	Ratchet Wheel
3	Ø	0414A0112P056	2	Guide Block Bearing-Outer Race
3	Ø	0414A0112P057	2	Guide Block Bearing-Inner Race
4	*7	0103A2049P002	1	Control House Heater (115v a-c)
4	*7	0103A2049P001	1	Control House Heater (230v a-c)
4	10	0193A4943P001	1	Prop Reset Spring
4	*17	0456A0866P005	2	Motor Limit Switches (normally open)
4	*17	0456A0866P006	1	Rear Motor Limit Switch (normally closed)
4	22	0103A1438P060	1	Cutoff and Anti-pump Relay-52Y-(48v d-c) (12HGA35A3)
4	22	0103A1438P059	1	Cutoff and Anti-pump Relay-52Y-(125v d-c) (12HGA35A2)
4	22	0103A1438P058	1	Cutoff and Anti-pump Relay-52Y-(250v d-c) (12HGA35A1)
4	22	0103A1438P106	1	Cutoff and Anti-pump Relay-52Y-(230v a-c) (12HGA35A5)
4	*Ø	006306774G008	1	Cutoff and Anti-pump Relay Coil-(48v d-c)
4	*Ø	006306774G004	1	Cutoff and Anti-pump Relay Coil-(125v d-c)
4	*Ø	006306774G002	1	Cutoff and Anti-pump Relay Coil (250v d-c)
4	*Ø	006306774G002	1	Cutoff and Anti-pump Relay Coil-(230v a-c)
4	Ø	0193A4945P001	1	Charge-discharge Indicator Spring
5	9	0414A0112P059	2	Motor Support Housing - Outer Race
5	Ø	0414A0112P060	2	Motor Support Housing - Inner Race
9	*13	006174582G039	1	Closing Coil - 52CC - (48v d-c)
9	*13	006174582G022	1	Closing Coil - 52CC - (125v d-c)
9	*13	006174582G002	1	Closing Coil - 52CC - (250v d-c)
9	*13	006174582G010	1	Closing Coil - 52CC - (230v a-c)
9	*16	0456A0866P005	1	Closing Latch Monitoring Switch (Normally Open)
9	17	0193A4946P001	1	Closing Latch Spring
9	*22	0456A0866P005	1	Trip Latch Checking Switch (Normally Open)
9	29	0414A0112P058	1	Close Latch Roller

\*Recommended Renewal Parts

Ø Not Shown

FIG. NO.	REF. NO.	CATALOG NO.	QTY. PER MECH.	DESCRIPTION OF PART
10	*42	006174582G027	1Δ	Trip Coil - 52TC - (24v d-c)
10	*42	006174582G032	1Δ	Trip Coil - 52TC - (48v d-c)
10	*42	006174582G022	1Δ	Trip Coil - 52TC - (125v d-c)
10	*42	006174582G002	1Δ	Trip Coil - 52TC - (250v d-c)
10	*42	006174582G001	1Δ	Trip Coil - 52TC - (230v a-c)
10	94	0132A1416P001	1	Driving Chain and Connecting Link Complete
12	*70	0202A6386G002	1	Inner Latching Pawl with Bushing - Complete
12	*70	0202A6386G001	1	Outer Latching Pawl with Bushing - Complete
12	*74	0202A6386G003	1	Driving Pawl and Bushing - Complete
12	87	0161A4241P001	1	Driving Pawl Spring
12	∅	0193A4941P001	1	Inner Latching Pawl Spring
12	∅	0193A4941P001	1	Outer Latching Pawl Spring
20	* 1	006370567P059	2	Output Crank Bushing (Textolite)
20	* 2	006370568P051	2	Output Crank Main Shaft Bushing (Textolite)
20	* 3	006370567P059	2	Upper Link Bushing (Textolite)
20	* 4	0202A4508P001	2	Lower Link Bushing (Bronze)
20	* 5	0202A4508P001	2	Trip Latch Roller Bushing (Bronze)
20	* 6	0414A0112P037	2	Trip Latch Shaft Bearing (Ball Bearing)
20	* 7	0414A0112P056	2	Guide Block Bearing (Outer Race) (Roller Bearing)
20	* 8	0414A0112P057	2	Guide Block Bearing (Inner Race) (Roller Bearing)
20	* 9	0414A0112P050	2	Cam Shaft Bearing (Outer Race) (Roller Bearing)
20	*10	0414A0112P051	2	Cam Shaft Bearing (Inner Race) (Roller Bearing)
20	*11	0202A4508P002	2	Closing Prop Bushing (Textolite)
20	*12	006370567P042	2	Link Shaft Bushing (Textolite)
20	*13	0414A0112P061	2	Closing Latch Shaft Bearing (Needle Bearing)
20	*14	0193A4948P001	1	Driving Crank Bushing (Bronze)
20	15	0202A5595P002	1	Driving Pawl Bushing (Bronze)
20	*16	0202A5595P003	1	Driving Link Bushing (Bronze)
20	*17	0414A0112P097	2	Driving Eccentric Shaft Bearing (Outer Race) (Roller Bearing)
20	*18	0414A0112P100	2	Driving Eccentric Shaft Bearing (Inner Race) (Roller Bearing)
20	19	0202A5595P001	2	Latching and Safety Pawl Bushing (Bronze)
20	*20	0202A4508P001	1	Driving Eccentric Bushing (Bronze)
20	*21	0414A0112P053	1	Trip Latch Roller Bearing - (Inner Race)
20	*22	0414A0112P052	1	Trip Latch Roller Bearing-(Outer Race)
20	*23	0414A0112P053	1	Cam Follower Roller Bearing-(Inner Race)
20	*24	0414A0112P052	1	Cam Follower Roller Bearing-(Outer Race)

\*Recommended Renewal Parts      ∅ Not Shown

Δ Independent Dual Trip Coil Option – Any Voltage Combination of Two Coils

**GENERAL ELECTRIC COMPANY  
SWITCHGEAR BUSINESS DEPARTMENT  
PHILADELPHIA, PA 19142**

**GENERAL  ELECTRIC**