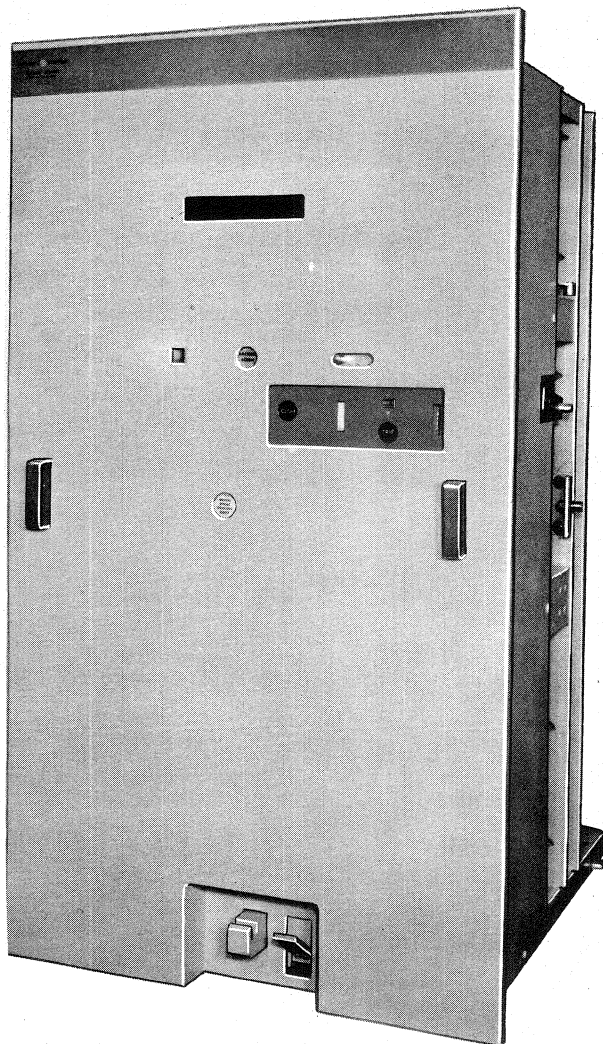




# INSTRUCTIONS

GEI-88772D

## VACUUM CIRCUIT BREAKER VH-13.8-500-0K



SWITCHGEAR PRODUCTS DEPARTMENT

GENERAL  ELECTRIC

PHILADELPHIA, PA.

# CONTENTS

	<u>Page</u>
INTRODUCTION . . . . .	3
RECEIVING, HANDLING AND STORAGE . . . . .	3
Storage . . . . .	3
INSTALLATION . . . . .	3
OPERATING PRINCIPLES . . . . .	4
Spring Charging . . . . .	7
Closing Operation . . . . .	7
Opening Operation . . . . .	7
Trip Free Operation . . . . .	7
ADJUSTMENTS . . . . .	7
Cam Follower Roller Clearance, The Trip Latch Clearance, Closing Latch Wipe, . . . . .	10
Primary Contact Gap, Primary Contact Wipe, Switches, Dashpot . . . . .	10
Driving Pawl and Motor Mount . . . . .	12
Latch Checking Switch (When Present) . . . . .	12
Spring Release Interlock . . . . .	12
Inspection and Test . . . . .	12
Control Power Check . . . . .	12
Opening and Closing Speeds . . . . .	13
MAINTENANCE . . . . .	13
Periodic Inspection . . . . .	13
The Breaker Element . . . . .	14
Hipot Testing of the Vacuum Interrupter . . . . .	14
Mechanism . . . . .	15
Insulator . . . . .	16
Lubrication . . . . .	16
Method of Cleaning Bearings . . . . .	16
Sleeve Bearings . . . . .	17
Roller & Needle Bearings . . . . .	17
Rolling Surfaces . . . . .	17
RECOMMENDED MAINTENANCE OF BREAKERS APPLIED TO NORMAL SWITCHING DUTY . . . . .	18
RECOMMENDED MAINTENANCE OF BREAKERS APPLIED TO REPETITIVE SWITCHING DUTY . . . . .	18
REPAIR AND REPLACEMENT . . . . .	18
Primary Disconnect Fingers . . . . .	18
Interrupters . . . . .	19
Primary Contact Studs . . . . .	19
Interlocking Switch . . . . .	19
Closing Latch Monitoring Switch . . . . .	19
Tripping Latch Checking Switch . . . . .	19
Motor Interlock and Light Switches . . . . .	19
Spring Release and Trip Coils . . . . .	19
RENEWAL PARTS . . . . .	21
ORDERING INSTRUCTIONS . . . . .	21

# VACUUM CIRCUIT BREAKER

## VH-13.8-500-OK

### INTRODUCTION

The vacuum breaker is a removable and interchangeable interrupting element for use in horizontal drawout metal-clad switchgear to provide reliable control and protection of electrical apparatus and power systems.

The VH-13.8-500-OK vacuum breaker is available with continuous current ratings of 1200 amperes and 2000 amperes in accordance with applicable industry standards. Refer to the breaker nameplate for complete rating information of any particular breaker. The nameplate also describes the control power requirements for that breaker. The application of a breaker must be such that its voltage, current and interrupting ratings are never exceeded. Since this book is written to include several ratings of the breaker as well as a number of design variations, the instructions will be of a general character and all illustrations will be typical unless otherwise specified.

Proper installation and maintenance are necessary to insure continued satisfactory operation of the breaker. The following instructions provide information normally required for placing the breaker in service and for maintaining satisfactory operation.

These instructions do not purport to cover all details or variations in equipment nor to provide for every possible contingency to be met in installation, operation or maintenance. Should further information be desired or should particular problems arise which are not covered sufficiently for the purchaser's purposes, the matter should be referred to the General Electric Company.

### RECEIVING, HANDLING AND STORAGE

Each breaker is carefully inspected and packed for shipment. Immediately upon receipt of the circuit breaker, an examination should be made for any damage sustained in transit. If injury or rough handling is evident, a damage claim should be filed immediately with the transportation company and the nearest General Electric Sales Office should be notified.

It is expected that due care will be exercised during the unpacking and installation of the breaker so that no damage will occur from careless or rough handling, or from exposure to moisture or dirt. Loose parts associated with the breaker are sometimes included in the same crate. Check all parts against the packing list to be sure that no parts have been overlooked.

### Storage

It is recommended that the breaker be put into service immediately in its permanent location. If this is not possible, the following precautions must be taken to insure the proper storage of the breaker:

1. The breaker should be carefully protected against condensation, preferably by storing it in a warm dry room. Circuit breakers for outdoor metal-clad switchgear should be stored in the equipment only when power is available and the heaters are in operation to prevent condensation.
2. The breaker should be stored in a clean location, free from corrosive gases, or fumes; particular care should be taken to protect the equipment from moisture and cement dust, as this combination has a very corrosive effect on many parts.
3. Unplated surfaces of rollers, latches, etc., should be coated with grease to prevent rusting.

If the breaker is stored for any length of time, it should be inspected periodically to see that rusting has not started and to insure good mechanical condition. Should the breaker be stored under unfavorable atmospheric conditions, it should be cleaned and dried out before being placed in service.

### INSTALLATION

1. The breaker has been shipped with the vacuum interrupter contacts secured in a closed position. Before inserting breaker into the metal-clad unit the securing wire must be removed from the operating mechanism trip latch, and the breaker tripped open.

Remove the right and left side covers and locate the trip latch securing wire as indicated by the yellow shipping tag. Cut the wire using wire cutting pliers or a similar tool and trip open the breaker by pushing the manual trip button (6) Figure 1. Keep your hands clear of the moving parts of the operating mechanism while cutting the wire and opening the breaker.

The shipping information plate located at the top of the front cover can now be removed. At this time a complete visual inspection of the breaker and mechanism should be made to ascertain their condition.

*These instructions do not purport to cover all details or variations in equipment nor to provide for every possible contingency to be met in connection with installation, operation or maintenance. Should further information be desired or should particular problems arise which are not covered sufficiently for the purchaser's purposes, the matter should be referred to the General Electric Company.*

*To the extent required the products described herein meet applicable ANSI, IEEE and NEMA standards; but no such assurance is given with respect to local codes and ordinances because they vary greatly.*

2. Charge the breaker closing spring using a 5/8" ratchet wrench to turn the manual charging shaft (1) Figure 3. Turning the shaft clockwise will advance the ratchet wheel and compress the spring. When the spring has reached the fully charged position, the yellow indicator (8), Figure 1 will read "charged" and the ratchet handle will rotate freely.

Loosen the bolts in the spring blocking interlock (1) Fig. 4 and move the slide toward the outside of the breaker until the spring blocking pin (2) can be inserted. Manually discharge the spring against the pin by pushing the manual close button (5) Fig. 1. The spring is now blocked and slow closing of the breaker can be accomplished by again turning the manual charging shaft with the ratchet wrench.

During the slow closing operation check to insure that the mechanism does not stick or bind during the entire stroke, that it latches securely in the closed position, and that it trips freely when the manually trip button is operated. The breaker should not be operated electrically until it has been operated several times manually to insure freedom of action. At this time, also check the following adjustments:

- a. Primary contact gap (Refer to page 10).
- b. Primary contact wipe (Refer to page 10).

**DO NOT WORK ON EITHER THE BREAKER OR MECHANISM UNLESS THE CLOSING SPRING IS BLOCKED AND THE OPENING SPRING HAS BEEN TRIPPED OPEN OR MECHANICALLY BLOCKED. THIS PRECAUTION IS REQUIRED TO PREVENT ACCIDENTAL CLOSING OR TRIPPING.**

After the adjustments have been checked, the closing spring can be unblocked. Rotate the manual charging shaft until the springs are fully charged and the ratchet wheel can no longer be advanced. The spring blocking device can now be removed and the slide (1) Fig. 4 should immediately be moved back in place. The closing and opening springs can now be discharged by pushing first the CLOSE button and then the TRIP button.

3. Attach the test coupler to the right hand coupler of the circuit breaker, that is, the coupler closest to the middle of the breaker, or insert the breaker in the housing to the test position and operate electrically several times. Check the control voltage as described under "Control Power Check", page 12.

**NOTE:** If the breaker secondary wiring is to be given a hi-potential test at 1500 volts, remove both the motor leads from the terminal connection. Failure to disconnect the motor from the circuit may cause damage to the winding insulation.

4. Remove the test coupler.
5. To assure interrupter reliability a 60 Hz. high potential test should be applied to each \*PowerVac interrupter as described in Hipot Testing of Vacuum Interrupter page 14, before energizing breaker.
6. During normal high voltage operation a charge is acquired by the main shield of the interrupter, and may be retained after the breaker is removed from the housing. Therefore, the midband ring of the interrupter should be discharged to ground by a grounding stick or other similar device before touching the interrupter.
7. Refer to metal-clad instruction book GEK-7330 for final instructions, before inserting the breaker into the metal-clad unit.

### OPERATING PRINCIPLES

The vacuum breaker has two principle components, the breaker element and the operating mechanism. The breaker elements are three similar units, the main element being a vacuum power interrupter (1) Fig. 5 whose main contacts are hermetically sealed in a high vacuum chamber. The primary connections to the associated metal-clad switchgear are made through the finger contacts in the back of the breaker (2) Fig. 5. The operating mechanism moves a vertical square shaft (2) Fig. 3 that closes the contacts of the interrupter through the contact springs (2) Fig. 6.

The ML-15 operating mechanism is of the stored energy type designed to give high speed closing and opening. The mechanism will operate on ac or dc voltage as indicated on the breaker nameplate. Closing and opening operations are controlled electrically by the metal-clad or remote relaying and mechanically by the manual close and trip buttons on the breaker. All secondary connections from the breaker to the metal-clad unit are made through the couplers (2) Fig. 7.

A positive interlock (1) Fig. 8 works with the racking screw shutter (2) Fig. 9 to prevent insertion or removal of the breaker when the contacts are closed. It also prevents closing the breaker except in the fully connected or test position. Electrical operation of the breaker is also prevented by the interlock linkage.

The spring release interlock (3) Fig. 10 trips open the breaker and discharges the closing spring whenever the breaker is inserted or removed from the housing. Closing and opening springs are discharged automatically, as a safety precaution.

The position stop (4) Fig. 3 positions the breaker in the disconnected and test position. The breaker will stop in the disconnected position when it is pushed into the metal-clad. Releasing the stop with the foot pedal (1) Fig. 2 and turning the racking screw (10) Fig. 3 will move the breaker to the test position. Again releasing the stop with the foot pedal the breaker can be moved to the fully connected position.

\* Registered trademark of General Electric Co.

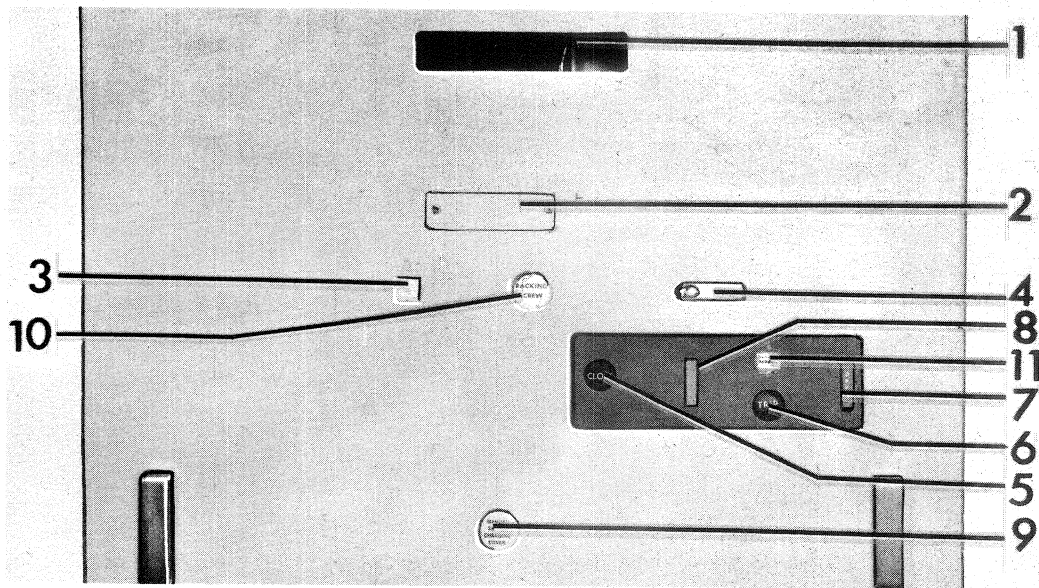


Figure 1 (8039302) Breaker Front

- |                                     |  |
|-------------------------------------|--|
| 1. Window                           | 7. Open-Close Indicator                    |
| 2. Removable Plate (for padlocking) | 8. Spring Charge Indicator                 |
| 3. Position Indicator               | 9. Removable Cover for Spring Charge Shaft |
| 4. Slide for Racking Screw Shutter  | 10. Racking Screw                          |
| 5. Manual Close Button              | 11. Operation Counter                      |
| 6. Manual Trip Button               |  |

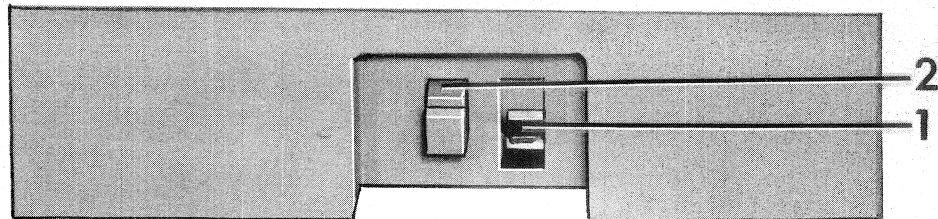


Figure 2 (8039302) Lower Front Panel

1. Foot Pedal (Position Stop Release)
2. Lifting Pad for Swivel Wheel

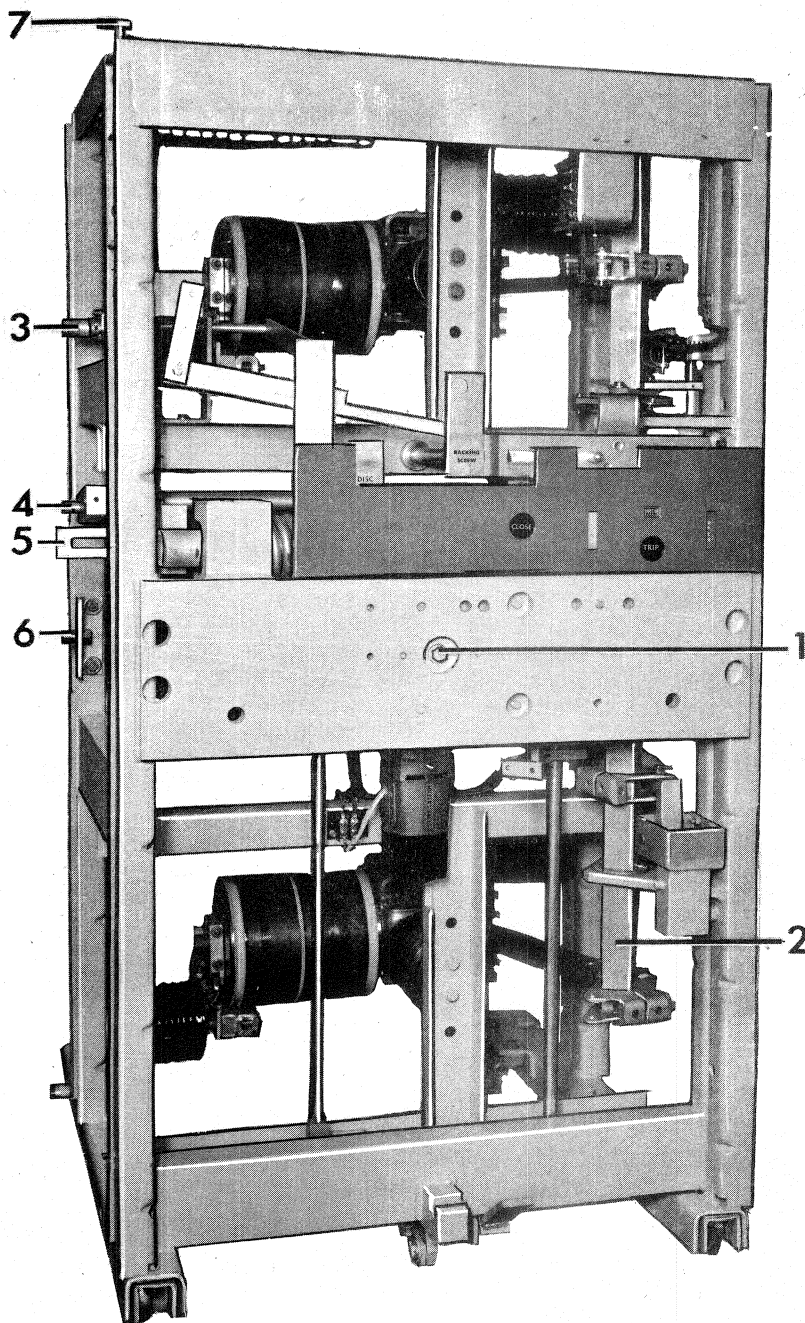


Figure 3 (8039287) Breaker, Covers Removed

1. Manual Charging Shaft
2. Square Shaft
3. Position Indicator Roller
4. Position Stop Roller
5. Spring Blocking Slide
6. Shutter Operator
7. Key Interlock

position of the breaker in the disconnect and test positions. Remote electrical position indication is accomplished by switches in the metal-clad actuated by a roller on the breaker (4) Fig. 7.

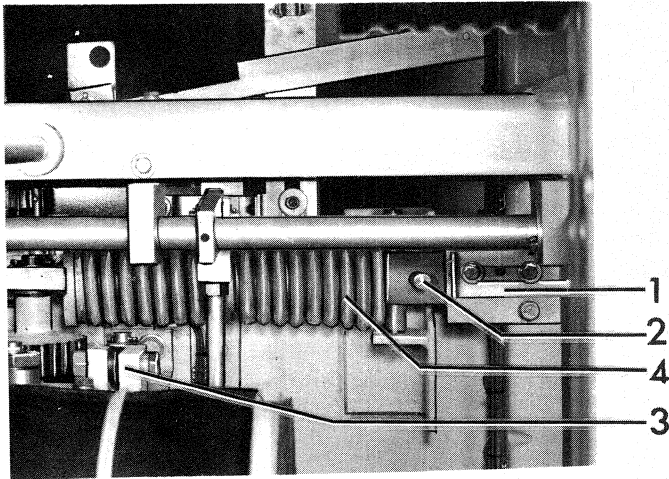


Figure 4. (8039296) Closing Spring

1. Spring Blocking Interlock
2. Spring Blocking Pin
3. Top of Motor Mounting
4. Closing Spring

A crank (5) Fig. 7 can be provided to operate additional auxiliary switch contacts provided in the metal-clad unit.

The breaker can be padlocked in either the fully connected or test positions so that it cannot be moved from that position. The lock secures the racking screw shutter preventing access to the racking mechanism.

#### Spring Charging

The mechanism has a high speed gear motor that compresses a closing spring through the action of an eccentric, pawl and ratchet assembly. The rotary action of the motor (5) Fig. 13 is converted to a straight stroke pumping action through the eccentric (1) Fig. 14 that carries a spring loaded driving pawl (2). The pawl advances the ratchet wheel (4) Fig. 14 only a few degrees each stroke where it is held in position by the latching pawl (3). When the ratchet wheel has been rotated approximately 180 degrees, the closing spring will be fully compressed. As the ratchet wheel continues to rotate, the spring load will shift over center and attempt to discharge. After only a few degrees of rotation, the closing roller (4) Fig. 15 will engage the closing latch (3) and the compressed spring will be held in repose until a closing operation is required. During the last few degrees of the ratchet wheel rotation, the motor and relay switches (1) Fig. 16 are released and the driving pawl is on a smooth portion of the ratchet wheel. This allows the motor and driving mechanism to coast to a natural stop expending all residual energy.

The closing spring may be charged manually if control voltage is lost. A 5/8" ratchet wrench can be used to rotate the manual charging shaft continuously in a clockwise direction until the yellow indicator reads charged, and the ratchet handle is free. The use of the ratchet wrench provides for maximum safety in the event that control power is suddenly restored without warning. In this event, the motor will take over again and continues to charge the spring.

#### Closing Operation

Closing the breaker is accomplished by energizing the closing solenoid or by manually pressing the close button. In either case, the closing latch is removed from the spring blocking location allowing the spring to discharge. The energy of the spring moves the cam (1) Fig. 15 that closes the breaker through a simple linkage that remains trip-free at all times. A monitoring switch (1) Fig. 13 on the closing latch will start the spring charging motor when it is fully reset after a closing operation.

#### Opening Operation

The breaker can be opened either electrically by energizing the trip coil (2) Fig. 17 or manually by pushing the trip lever (6) Fig. 1. In each method the trip shaft and latch (3) Fig. (18) is rotated permitting the operating mechanism to collapse. The energy stored in the opening spring is released opening the breaker. At the end of the opening operation the dashpot (1) Fig. (19) will stop the contacts and linkage and absorb any excess energy from the system thereby limiting contact rebound. During this operation, the trip coil circuit is deenergized and upon completion of the opening operation, the operating mechanism is returned to its reset position, ready for closing.

#### Trip Free Operation

If the trip coil circuit is energized while the breaker is closing, the trip plunger will move the trip latch (5) Fig. 15 away from the trip roller (6) causing the mechanism linkage to collapse and the breaker to perform a close open operation. The closing cam (2) will complete its closing stroke and the springs will recharge as in a normal closing operation.

## **ADJUSTMENTS**

All adjustments should be checked during periodic inspections and whenever it becomes necessary to repair or replace parts that have become worn or defective while in service. First, remove the breaker from the metal-clad unit and remove the left and right side covers. The following adjustments are listed in the order in which they are to be checked.

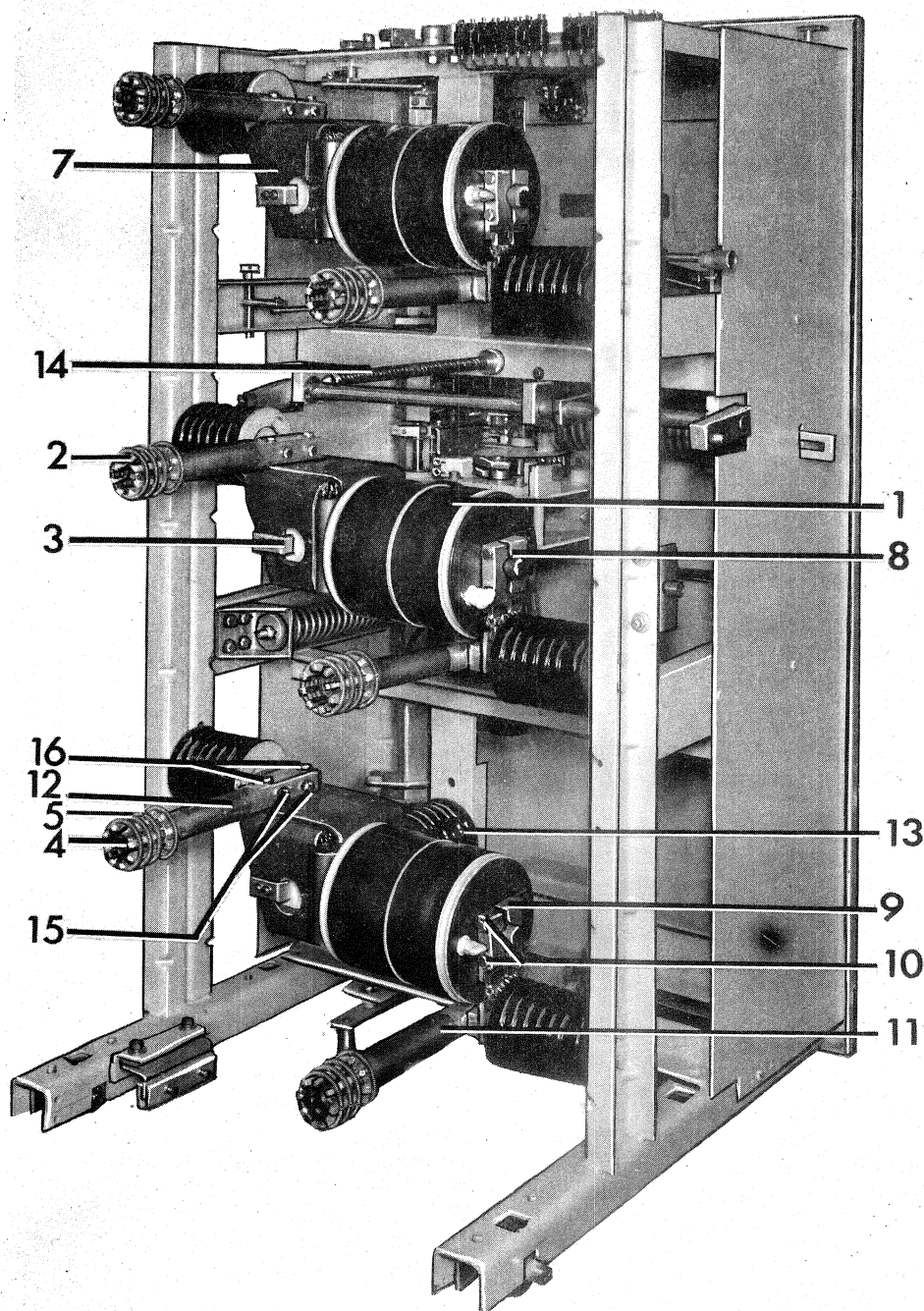


Figure 5 (8039293) Rear of Breaker

- |                              |                                       |
|------------------------------|---------------------------------------|
| 1. Vacuum Power Interrupter  | 9. Braid Conn.                        |
| 2. Finger Contacts           | 10. 2 Holding Bolts                   |
| 3. Indicator Pointer         | 11. Left Hand Stud                    |
| 4. Bolt and Retainer         | 12. Right Hand Stud                   |
| 5. Primary Disconnect Spring | 13. Insulator                         |
| 7. Wipe Cage                 | 14. Racking Screw                     |
| 8. Braid Conn.               | 15. Right Hand Stud Bolts             |
|                              | 16. Interrupter Support Holding Bolts |



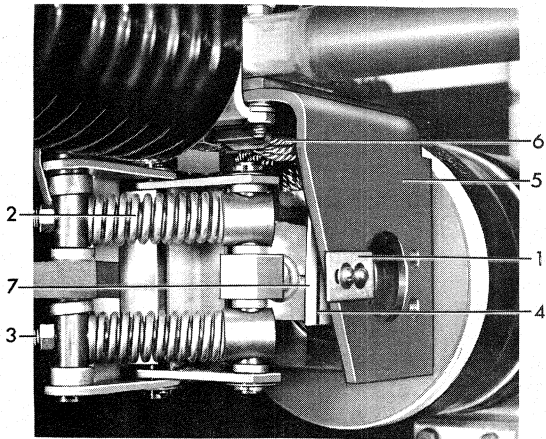


Figure 6. (8039286) Wipe cage

- |                      |              |
|----------------------|--------------|
| 1. Indicator Pointer | 4. Red Line  |
| 2. Contact Springs   | 5. Wipe Cage |
| 3. Spring Guide      | 6. Braid     |
|                      | 7. Indicator |

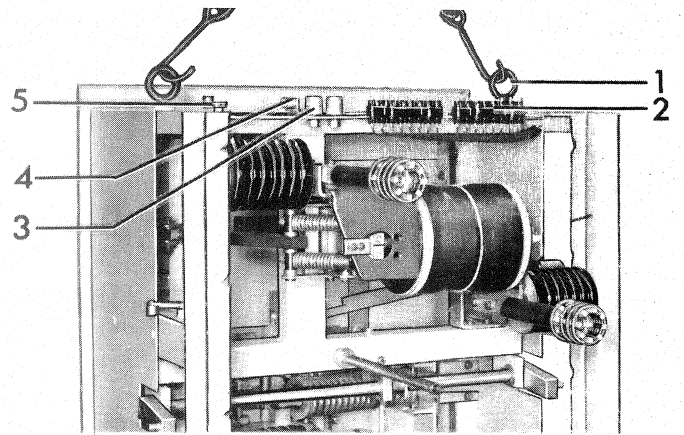


Figure 7. (8039300) Top of the Breaker

- |                                   |
|-----------------------------------|
| 1. 5/8" Lifting Eye Bolts         |
| 2. Secondary Couplers             |
| 3. Breaker Guide                  |
| 4. Roller for Position Switch Cam |
| 5. Crank for Auxiliary Switch     |

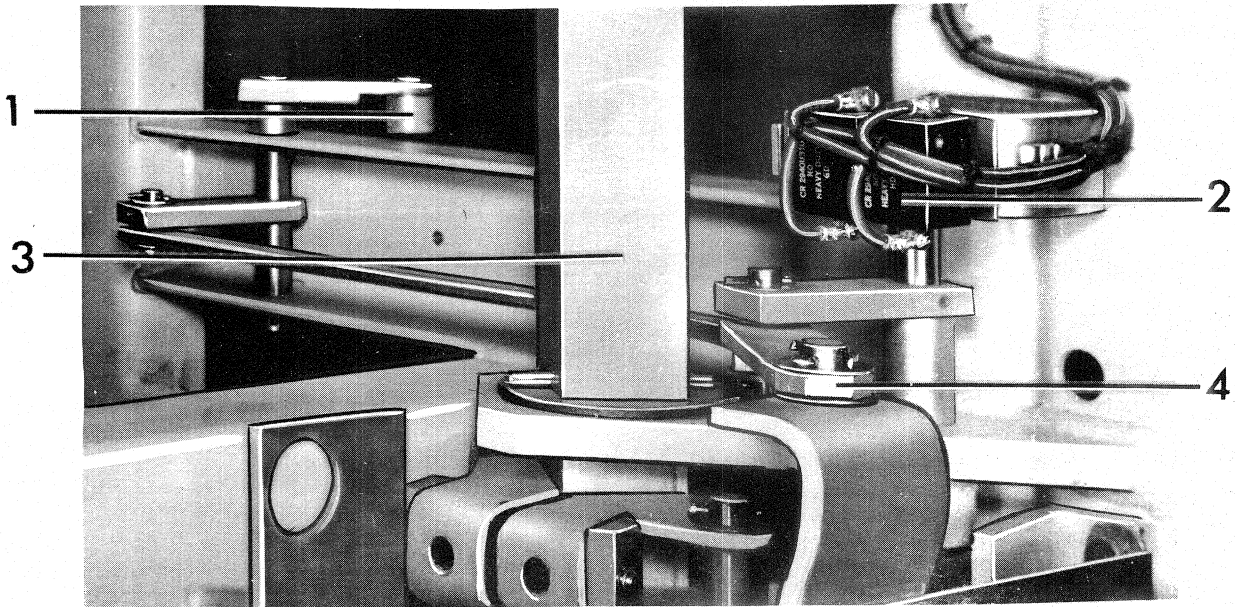


Figure 8. (8039292) Positive Interlock

- |                               |
|-------------------------------|
| 1. Positive Interlock Roller  |
| 2. Positive Interlock Switch  |
| 3. Square Shaft               |
| 4. Positive Interlock Linkage |

DO NOT WORK ON EITHER BREAKER OR MECHANISM UNLESS THE CLOSING SPRING IS BLOCKED AND THE OPENING SPRING HAS BEEN TRIPPED OPEN OR MECHANICALLY BLOCKED. THIS MEASURE IS REQUIRED TO PREVENT ACCIDENTAL CLOSING OR TRIPPING.

Cam Follower Roller Clearance

Refer to Fig. 15. With the Breaker in the tripped position and the closing spring charged, check the clearance between the cam follower roller (1) and the cam (2). It should measure .030 to .060. If adjustment is necessary, loosen check nut (3) Fig. 20 and adjust the stop (4) until the correct clearance is obtained. Tighten the check nut and remeasure the clearance (close and trip the breaker before checking the adjustment.)

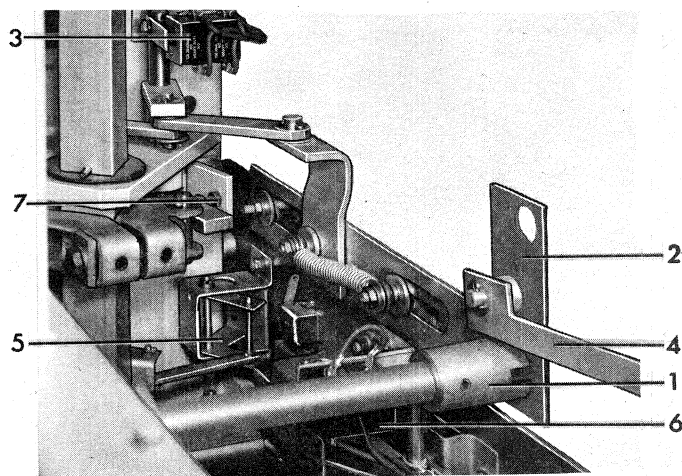


Figure 9. (8039295) Racking Screw Shutter

- 1. Racking Screw
- 2. Racking Screw Shutter
- 3. Interlock Switch
- 4. Link (from Key Interlock)
- 5. Close-Open Indicator
- 6. Motor Switch
- 7. Adjustment Screw for Blocking Prop

The Trip Latch Clearance

Refer to Fig. 15. With the breaker in the tripped position and the closing spring charged, check the clearance between the trip latch (5) and the trip roller (6). It should be .030" to .060". If adjustment is necessary, loosen check nut (8) and adjust stop pin (7).

Closing Latch Wipe

Refer to Fig. 15. The closing latch (3) should strike the closing roller (4) approximately in the center. Apply a thin film of grease to the end of the closing latch and charge and block the closing springs. Release the closing latch by pushing the "close" button. Inspect the end of the latch for proper wipe.

If adjustment is necessary, loosen switch (1) Fig. 13 and move for clearance. Loosen nut and adjust stop (4) until the proper wipe is obtained. Secure the stop nut and reset switch (1) as listed under Switch Adjustment page 19.

Primary Contact Gap

Refer to Fig. 21. With the breaker closed, press the manual trip button allowing the breaker to open normally. The gap between the primary contacts should be  $3/4" + 0-1/32"$ . Indicator (4) moves with the contact rod of the interrupter and can be used to measure the contact gap. Mark the indicator with a pencil where the pointer (1) indicates. Close the breaker by the manual closing wrench and measure the distance from the pointer to the pencil mark. To change the contact gap the operating rod adjustment screw (2) Fig. 12 is used. Loosen nuts (1) and (3) and turn the hex center of the double ended adjustment screw to increase or decrease the gap. One full turn will close or open the contact gap approximately  $1/8"$ . Tighten the locking nuts and remeasure the gap after closing and tripping the breaker.

Primary Contact Wipe

When the breaker is closed, the primary contact springs (2) Fig. 21 should be compressed  $5/16" + 0 - 1/32"$ . This dimension will vary with breaker use and can be used without readjustment down to  $3/16"$ . The measurement can be made on the spring guide.

To adjust the contact wipe loosen the operating rod bolt (4) Fig. 12 and move the rod toward the square shaft to decrease wipe and away from the shaft to increase wipe. Be certain the serrated washers (5) are seated properly before tightening the bolt. Close the breaker and remeasure the gap at the spring guide.

WHEN WORKING ON THE MECHANISM IN THE CLOSED POSITION, KEEP FINGERS CLEAR OF THE LINKAGE, AS ACCIDENTAL TRIPPING CAN CAUSE SEVERE INJURY.

Switches

The strikers for operating the motor switch (3) Fig. 22, positive interlock switches (2) Fig. 8, closing latch monitoring switch (1) Fig. 13 and trip latch checking switch (1) Fig. 23 should be adjusted to a clearance of  $1/64"$  to  $1/32"$  from the switch support. The switch supports should be loosened and the switch moved to obtain this dimension.

Dashpot

SEE APPENDIX A

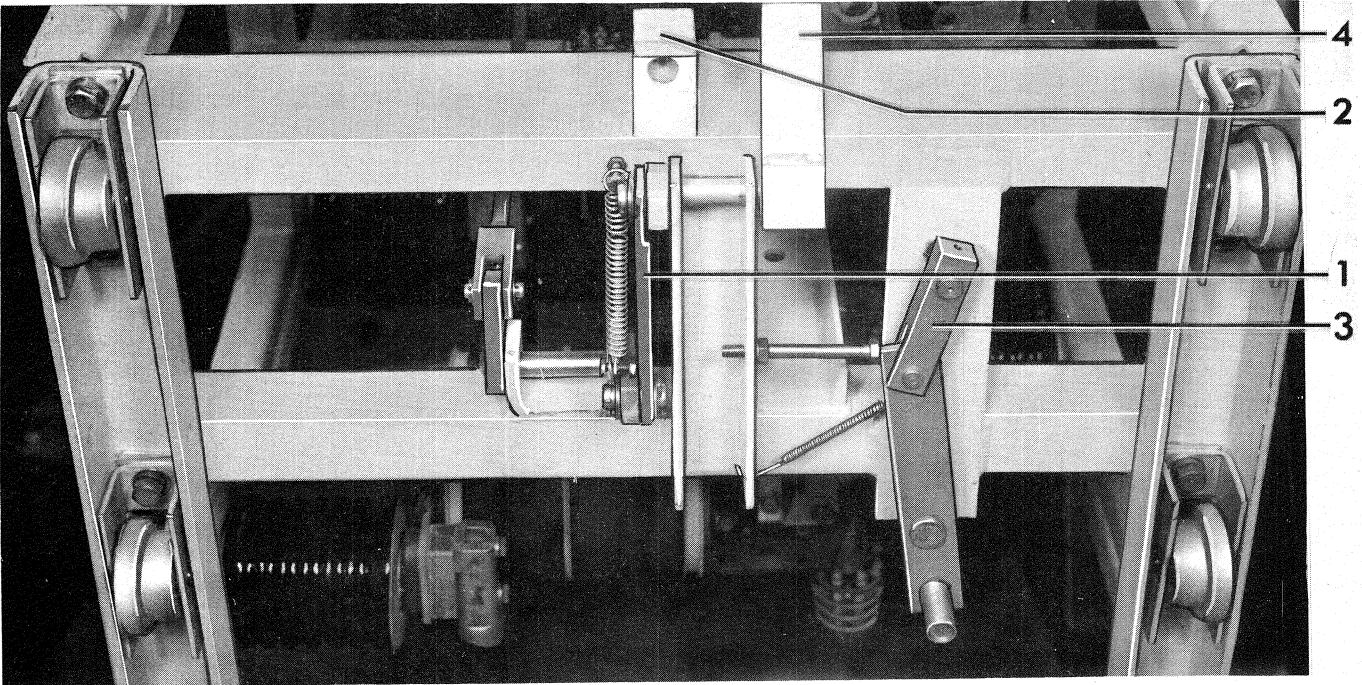


Figure 10. (8039380) View From Underneath

- |                               |                             |
|-------------------------------|-----------------------------|
| 1. Position Stop Release Mech | 3. Spring Release Interlock |
| 2. Support for Fifth Wheel    | 4. Footpedal                |

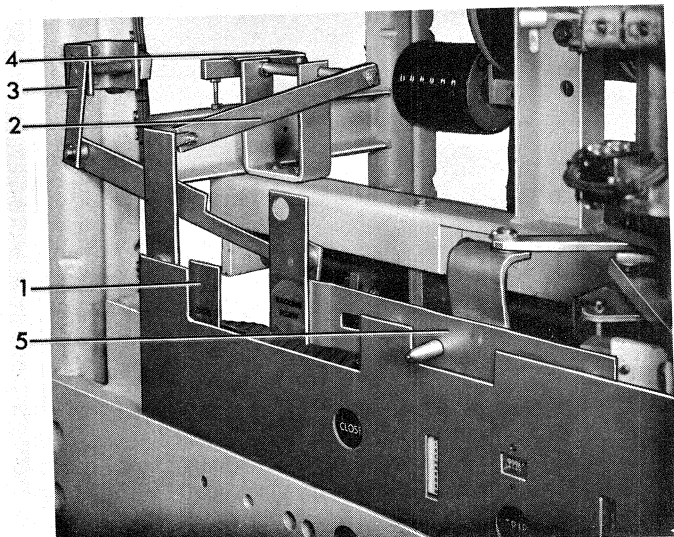


Figure 11. (8039376) Racking Screw Shutter

1. Position Indicator
2. Position Indicator Linkage
3. Key Lock Linkage
4. Position Indicator Roller
5. Racking Screw Shutter

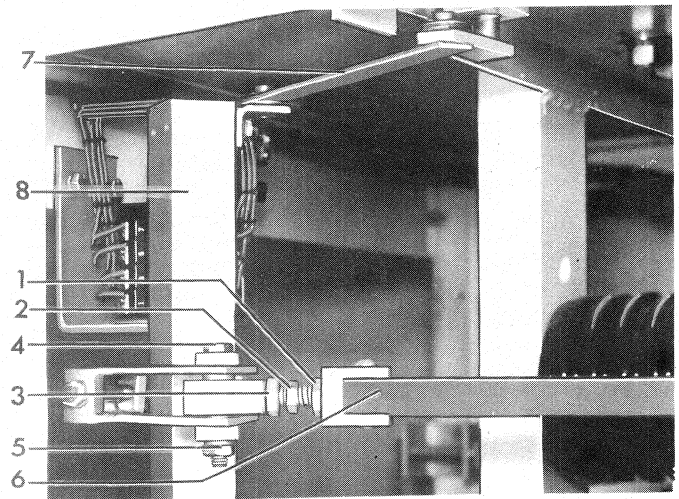


Figure 12. (8039294) Operating Rod

1. Nut
2. Adjustment Screw
3. Nut
4. Operating Rod Bolt
5. Serrated Washer
6. Operating Rod
7. Crank to Operate Auxiliary Switch
8. Square shaft

Inspection and Test

1. For ease in reviewing the adjustments, the following are recapitulated:
  - a. Cam follower roller clearance .030" to .060".
  - b. Primary contact gap  $3/4" + 0 - 1/32"$ .
  - c. Primary contact wipe  $5/16 + 0 - 1/32"$ .
  - d. Switches - clearance from support  $1/64"$  to  $1/32"$ .
  - e. The trip latch clearance .030" to .060".
  - f. The closing latch is centered.
  - g. Latching pawl clearance .020" to .040".
  - h. Latch checking switch contacts make when the gap between the trip latch and the stop is  $1/16"$  max.
2. Check all nuts, washers, bolts, cotter pins, and terminal connections for tightness.
3. Inspect all wiring to make sure that no damage has resulted during installation, and test for possible grounds or short circuits.
4. See that all bearing surfaces of the mechanism have been lubricated. Refer to the section on LUBRICATION.
5. Operate the breaker slowly with the manual charging wrench and note that there is no excessive binding or friction and that the breaker can be moved to the fully opened and fully closed positions.
6. See that any place where the surface of the paint has been damaged is repainted immediately.
7. Check the trip coil plunger and the release coil plunger to see that they move freely.

Control Power Check

After the mechanism has been closed and opened slowly several times with the maintenance closing wrench and the mechanism adjustments are checked as described, the operating voltages should be checked at the release coil, trip coil, and motor terminals. For electrical operation of the mechanism, the control power may be either alternating or direct current. The operating ranges for the closing and tripping voltages are given on the breaker nameplate. The following ranges are standard:

Rated Normal Voltage	Close		Trip	
	Min.	Max	Min	Max
24V dc	-	-	14V	30V
48V dc	34V	50V	28V	60V

Driving Pawl and Motor Mount

The manual driving pawl (1) Fig. 24 must advance the ratchet wheel (2) sufficiently to allow the latching pawl (3) Fig. 14 to fall into the ratchet teeth. Since the latching pawl is an integral part of the motor mount, the entire mounting must be moved to allow a clearance between the latching pawl and the ratchet tooth of .020" to .040" when the driving pawl is full advanced and the maximum load of the closing spring is on the ratchet.

After checking the pawl clearance and determining the amount of movement required in the motor mount, the check nut (5) Fig. 14 and bolt (6) can be removed and the necessary shim washers (7) added to or removed from the assembly. Replace the bolt and hand tighten, then turn approximately 1/2 turn with a wrench. Hand wind the closing spring and again check the clearance with the closing spring load applied. Secure the bolt (6) by replacing nut (5) on the assembly.

Latch Checking Switch (when present)

Refer to Fig. 23. The latch checking switch (1) must make contact when the latch is within  $1/16"$  of the latch stop. Rotate the trip latch away from the stop by pushing the trip button (6) Fig. I. Allow the latch to reset slowly until the switch contacts close. This can be checked by the use of an indicator light or a bell set. The dimension should be a maximum of  $1/16"$  from the latch to the support. If adjustment is necessary, move the switch support (7).

Spring Release Interlock

A spring release interlock shown in Fig. 10, will assure that the breaker contacts are open and the closing springs are discharged when the breaker is being inserted or withdrawn from the metal-clad unit, the release interlock will trip the breaker open and hold the mechanism in a trip-free position while discharging the closing springs.

Rated Normal Voltage	Close		Trip	
	Min.	Max	Min	Max
125V dc	90V	130V	70V	140V
250V dc	180V	260V	140V	280V
115V ac	95V	125V	95V	125V
230V ac	190V	250V	190V	250V

If the closed circuit voltage at the terminals of the coil or motor does not fall in the specified range, check the voltage at the source of power and line drop between the power source and breaker.

When two or more breakers operating from the same control power source are required to close simultaneously, the closed circuit voltage at the closing coil or motor of each breaker must fall within the specified limits.

Electrical closing or opening is accomplished by merely energizing the closing or trip coil circuit. Control switches can be provided for this purpose on the metal-clad unit or control board. It is also possible to trip or close the breaker manually by pressing the manual trip button (6) Fig. 1, or the manual close button (5). When the breaker is closed, the close button is interlocked to prevent release of the closing spring.

Opening and Closing Speeds

The opening speed of the interrupter contacts should be from 6 to 7-1/2 ft. /sec. and the closing speed from 4.0 to 5 ft./sec.

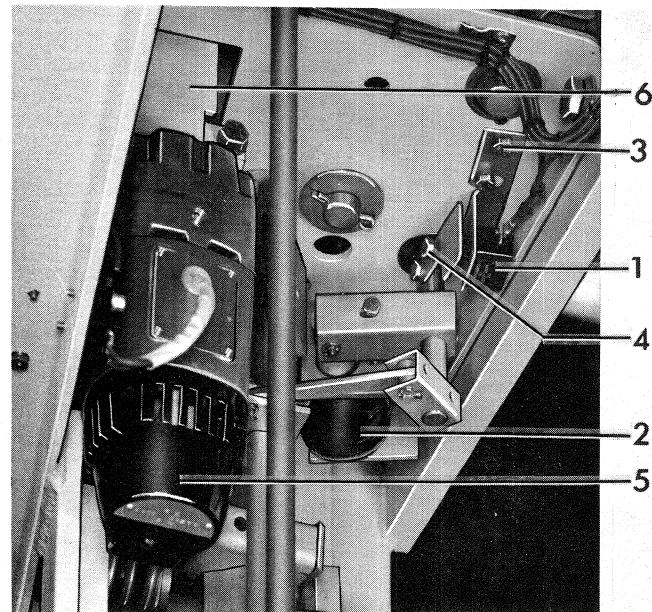


Figure 13. (8039314) Motor Mounting

1. Closing Latch Monitoring Switch
2. Closing Coil
3. Switch Adjustment
4. Closing Pawl Adjustment Nut
5. Motor
6. Motor Mounting Block

The opening speed is the average speed measured from contact parting to a 5/8" gap. The closing speed is the average speed measured over the last 1/4" before contact closing.

**MAINTENANCE**

Before any maintenance work is performed, make certain that all control circuits are opened and that the breaker is removed from the Metal-Clad unit. **DO NOT WORK ON THE BREAKER OR MECHANISM WHILE IN THE CLOSED POSITION UNLESS THE TRIP LATCH HAS BEEN SECURELY WIRED OR BLOCKED TO PREVENT ACCIDENTAL TRIPPING, OR THE MECHANISM IS BLOCKED TO PREVENT OPENING. DO NOT WORK ON THE BREAKER OR MECHANISM WHILE THE SPRINGS ARE CHARGED UNLESS THEY ARE SECURED IN THAT POSITION BY THE MAINTENANCE SPRING BLOCKING DEVICE.**

Periodic Inspection

The frequency of periodic inspection should be determined by each operating company on the basis of the number of operations (including switching), the magnitude of currents interrupted, and any unusual operations which occur from time to time. Operating experience will soon establish a maintenance schedule which will give assurance of proper breaker condition. On installations where a combination of fault duty and repetitive operation is encountered, an inspection is recommended after

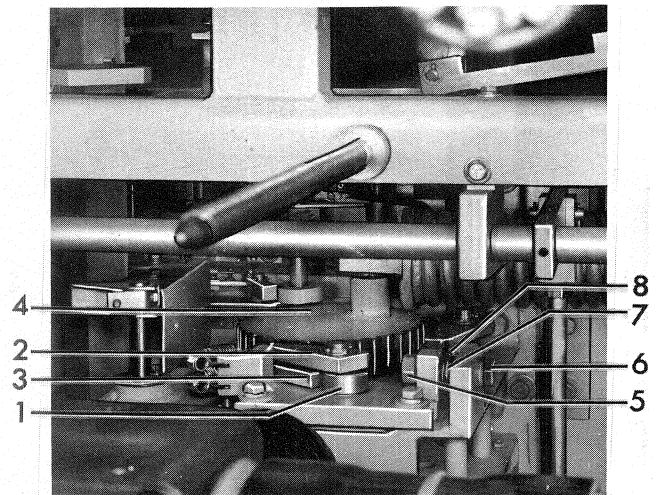


Figure 14. (8039310) Top of Mechanism

1. Eccentric Wheel
2. Driving Pawl
3. Latching Pawl
4. Ratchet Wheel
5. Check Nut
6. Bolt
7. Shimwashers
8. Buffer Springs

several severe fault operations or at 2000 operation intervals. The following instructions list the main points to be included in an inspection and a number of general recommendations.

The Breaker Element

The PowerVac interrupter used in this breaker is a reliable, safe, and clean interrupting element. Since the contacts are contained in a vacuum chamber, they remain clean and require no maintenance at any time. The metallic vapors eroded from the contact surfaces during high current interruption remain in the chamber and are deposited on metal shields thus insuring a high dielectric value of the vacuum and the walls of the glass container.

Only two simple checks are required to assure reliable interruption:

1. A maximum contact erosion of 1/8" is allowed. This is easily determined by checking the indicator (1) Fig. 21 when the breaker is in the closed position. A red line 1/8" wide and an indicating finger have been set at the factory so that the finger is at the front edge of the line. As

the contacts erode, the line will become visible. When the full 1/8" line is exposed the Power Vac interrupter should be replaced.

2. A hipot test of the interrupter will determine the internal dielectric condition.

Hipot Testing of Vacuum Interrupter

High potential testing, in addition to careful visual inspection, provides the best means of verification of the condition of the interrupter. Each interrupter should be given 60 Hz ac high potential test of 36 kV rms for one minute across its open contacts before the breaker is put into service and the same test should be applied to the interrupters whenever the breaker is serviced.

Prior to applying voltage to the interrupter, the surface of its insulating envelop should be wiped clean of any surface contaminants. Normally, wiping with methanol poured on a clean cloth or with an industrial wiper will be sufficient.

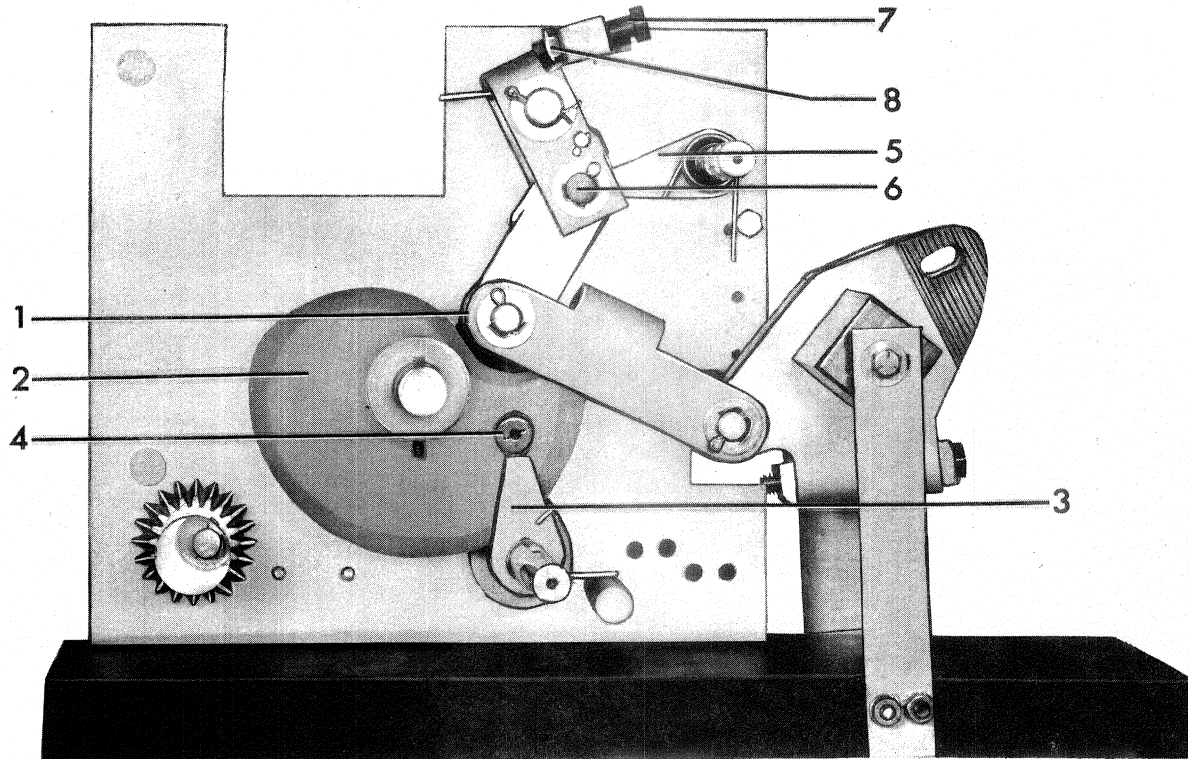


Figure 15. (8039445) Mechanism Linkage (Motor Mounting and Upper Plate of Mechanism Frame are Removed)

- |                         |                      |
|-------------------------|----------------------|
| 1. Cam Follower Roller  | 5. Trip Latch        |
| 2. Cam                  | 6. Trip Latch Roller |
| 3. Closing Latch        | 7. Adjustment Bolt   |
| 4. Closing Latch Roller | 8. Check Nut         |

A high potential voltage source is then connected across the open interrupter contacts and the voltage slowly increased to the test voltage. A withstand of 36 kV rms ac for one minute is adequate to establish that the interrupter is in servicable condition.

**CAUTION:** Although the procedure for hipotting a vacuum interrupter is similar to that used for any other electrical device, there are two areas that require the exercise of extra caution.

1. During any hipotting operation the main shield inside the interrupter can acquire an electrical charge that usually will be retained even after the hipot voltage is removed. This shield is attached to the midband ring of the insulating envelop and a grounding stick should always be used to discharge the ring as well as the other metal parts of the assembly before touching the interrupter, connections, or breaker studs.
2. High voltage applied across open gaps in a vacuum can produce X-radiation that may constitute a health hazard on prolonged exposure at close range unless the source is adequately shielded. The patented internal shield of the G.E. Vacuum interrupter contributes to X-radiation control by providing a measure of radiation shielding.

During equipment operation in the normal current carrying mode there is no X-radiation because there are no open contacts. When the contacts are open in normal service on a maximum rated 15 kV system,

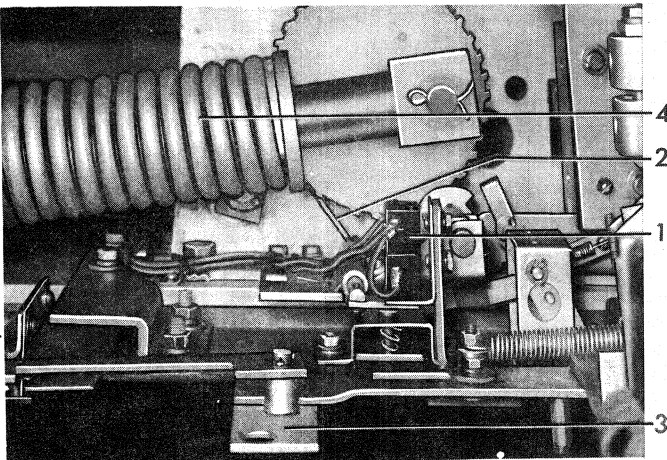


Fig. 16 (8039375) Top of Mechanism

1. Motor, Relay and Light Switch
2. Motor Switch Striker
3. Shutter
4. Closing Spring

the X-radiation at one meter (3 feet 3 inches) is well below the level of concern, and the metal equipment enclosure provides additional shielding.

As with any open contacts in a vacuum, hazardous X-radiation can be produced if the voltage across the contacts exceeds a certain level with a certain contact gap; therefore do not conduct hipot tests on the breaker at voltages higher than the recommended levels of 36 kV (rms) ac. During the hipot test, personnel should stand in front of the breaker to take advantage of the shielding afforded by the steel front panel and the partial sidepanels. If it is not practical to have operators located in front of the breaker during hipot testing, equivalent protection for such personnel can be obtained by limiting the number of tests to 12 per hour (4-3 phase breakers) with personnel no closer than 2 meters (6 feet 6 inches).

### Mechanism

A careful inspection should be made to check for loose nuts or bolts and damaged parts. All cam, roller, and latch surfaces should be inspected for any evidence of damage or excessive wear. Lubricate the mechanism as outlined below, then using the manual charging wrench, open and close the breaker several times to make certain that the mechanism operates freely throughout its stroke. Check the mechanism adjustments as specified under ADJUSTMENTS. Check all terminal connections.

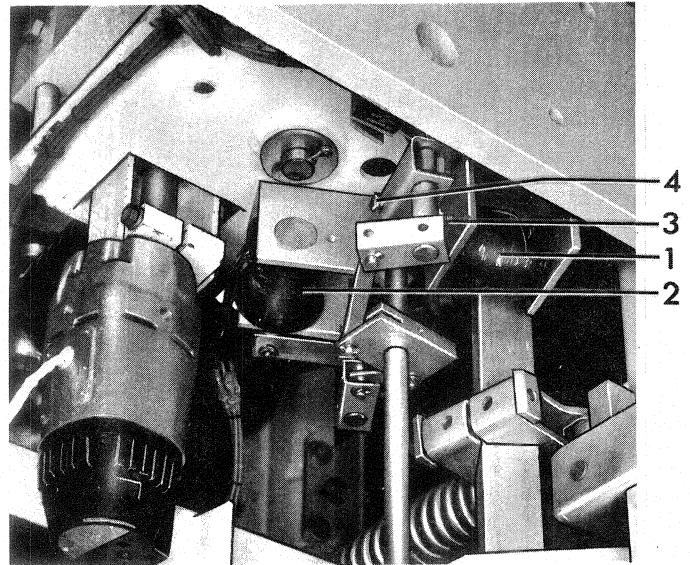


Fig. 17 (8039317) Coil Arrangement

1. Closing Coil
2. Tripping Coil
3. Adjustment Bolt For Trip Shaft Paddle
4. Stop Bolt

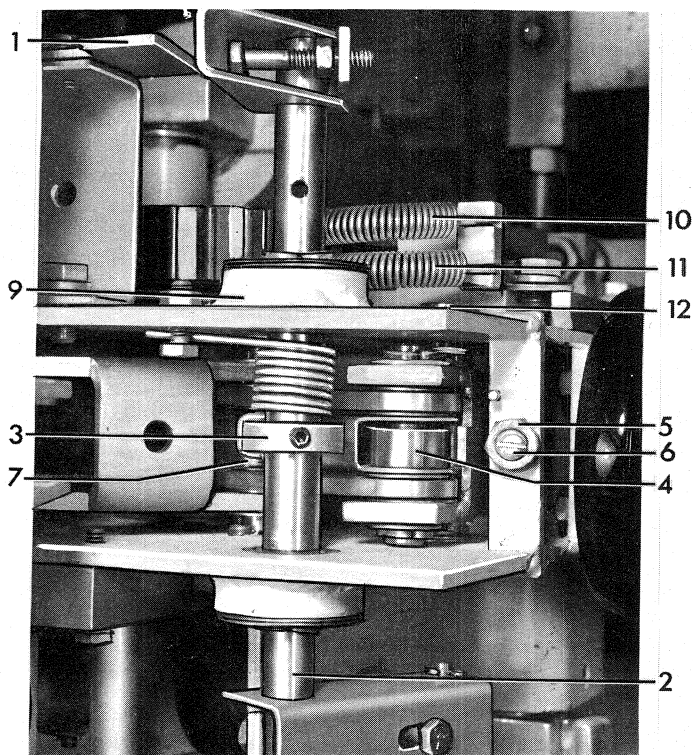


Figure 18. (8039318) Mechanism Linkage

1. Trip Lever
2. Trip Shaft
3. Trip Latch
4. Trip Roller
5. Check Nut
6. Stop Pin
7. Cam Follower Roller
8. Latch Roller
9. Trip Shaft Bearing
10. Driving Pawl Spring
11. Holding Pawl Spring
12. Location of Trip Latch Check Switch

### Insulator

The porcelain insulators should be wiped clean with a dry cloth or industrial wipers. A thorough inspection should be made and damaged insulators replaced.

### Lubrication

In order to maintain reliable operation, it is important that all circuit breakers be properly lubricated at all times. Most of the bearings and rolling surfaces utilize a new type of dry lubrication that will require no maintenance and will last the life of the equipment. A few bearings and surfaces listed in Table I require lubrication. These have been properly lubricated, during assembly at the factory, using the finest grades of lubricants available. However, even the finest oils and greases have a tendency to oxidize with age, as evidenced by hardening and darkening in color. Elimination of the hardened lubricant is essential for the proper operation of circuit breakers. Also frequent operation of the breaker

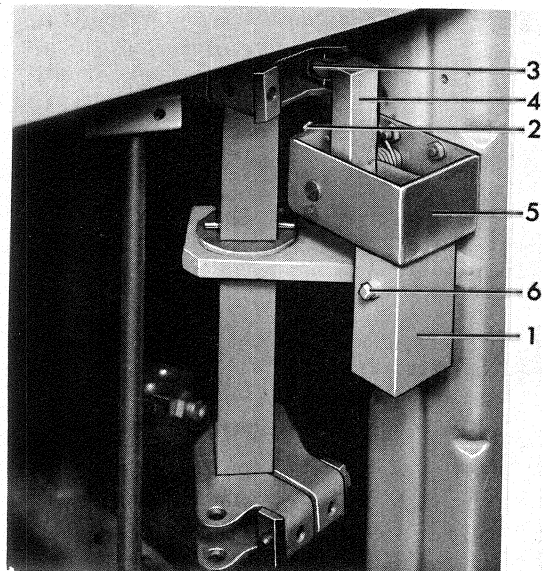


Figure 19. (8039309) Dashpot

1. Dashpot
2. Adjustment Screw
3. Buffer Rod Roller
4. Dashpot Buffer Link
5. Dashpot Support
6. Pipe Plug

causes the lubricant to be forced out from between the bearing surfaces. A simple lubrication will often clear up minor disturbances which might be mistaken for more serious trouble.

A definite lubrication schedule should be set up taking into consideration the frequency of operation of the breaker and local conditions. Until such a schedule is worked out, the breaker should be lubricated at each periodic inspection and also whenever it is overhauled, in accordance with the lubrication Table. It is also recommended that all circuit breakers be operated at regular intervals to insure the user that the equipment is operating freely.

The lubrication Table is divided into two methods of lubrication. The first method outlines the maintenance lubrication which should be performed at the time of periodic maintenance, and requires no disassembly. The second method outlines a lubrication procedure similar to that performed on the breaker at the factory, but should be used only in case of general overhaul or disassembly for other reasons.

General Electric Lubricant D50H15 is available in 1/4 pound collapsible tubes. It is so packaged to insure cleanliness and to prevent oxidation.

### Method of Cleaning Bearings

Whenever cleaning is required, as indicated in the lubrication table, the following procedures are



recommended.

Sleeve Bearings

The sleeve bearings used throughout the linkage utilize Teflon surfaces and do not require lubrication. After a number of operations, the surface will acquire a thin black film. Do not remove this film unless there is evidence of outside contaminants, such as dry or hardened grease. If contaminants are present, they should be removed by immersing the link and bearing in clean petroleum solvent or similar cleaner and using a stiff brush. Do not remove the bearings from the links. DO NOT USE CARBON TETRACHLORIDE.

The main shaft bearings should be removed, cleaned, and lubricated with G-E D50H15 lubricant at general overhaul periods.

Roller & Needle Bearings

The cam follower (1) Fig. 15 and latch roller bearings (4) (6) should be first removed from the mechanism and the inner race disassembled. They should then be placed in a container of clean petroleum solvent or similar cleaner. DO NOT USE CARBON TETRACHLORIDE. If the grease in the bearings has become badly oxidized, it may be necessary to use alcohol (type used for thinning shellac) to remove it. Ordinarily, by agitating the bearings in the cleaning solution, and using a stiff brush to remove the solid particles, the bearings can be satisfactorily cleaned. Do not handle the bearings with bare hands as deposits from the skin onto the bearings are inducive to corrosion. If the bearings are touched, the contamination can be removed by washing in alcohol. After the bearings have been thoroughly cleaned, spin them in a clean new light machine oil until the cleaner or solvent is entirely removed. Allow this oil to drain off and then repack them immedi-

ately with G-E lubricant D50H15 being sure all metal parts are greased. The removable seals should then be replaced.

**NOTE:** If it becomes necessary to clean the bearings in alcohol (shellac thinner), be sure the alcohol is perfectly clean, and do not allow the bearings to remain in the alcohol more than a few hours. If it is desirable to leave the bearings in the alcohol for a longer time, an inhibited alcohol such as is used for antifreeze should be used. Even then the bearings should be removed from the alcohol within twenty-four hours. Precautions against the toxic effects of the alcohol must be exercised by wearing rubber gloves and by using the alcohol in a well ventilated room; excessive exposure to the fumes is sometimes unpleasant to personnel. Washing the bearings in the light oil and draining should follow immediately, then apply the lubricant. Bearings that are pressed into the frame or other members such as the bearings for eccentric (1) Fig. 14, cam shaft bearings and trip and close shaft bearings should not be removed. After removing the shaft and inner race the bearing can usually be cleaned satisfactorily with petroleum solvent or a similar cleaner and a stiff brush. Follow the procedure outlined above using a light machine oil and G-E lubricant D50H15 before reassembling the inner race and shaft.

Rolling Surfaces

The surfaces of the ratchet wheel, cam, and pawls are lubricated with a baked-on, dry molybdenum disulfide coating. This requires no main-

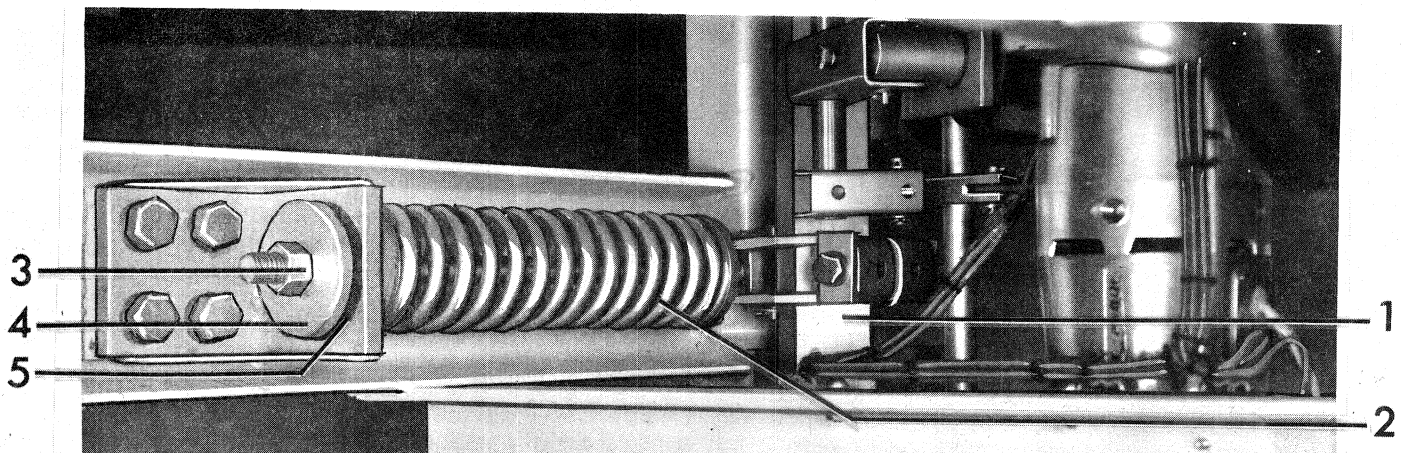


Figure 20 (8039315) Opening Spring

- 1. Square Shaft
- 2. Opening Spring
- 3. Nut
- 4. Plate
- 5. Rubber Buffer

\* Registered trademark of DuPont Co.

tenance and should last the life of the breaker.

## RECOMMENDED MAINTENANCE OF BREAKERS APPLIED TO NORMAL SWITCHING DUTY

Vacuum breakers applied to normal operations should be serviced and maintained according to the following schedule:

- A. Every 2000 operations, or every year, whichever comes first, the following should be accomplished:
  1. Make a visual inspection of the breaker and remove dust and contaminants from the vacuum interrupters, porcelain, and operating rods.
  2. A high potential test should be applied to the vacuum interrupters as outlined in Hipot Testing of Vacuum Interrupter, page 14.
  3. Check the Power Vac contact erosion indicator as described in the breaker element, page 14.
  4. Check the breaker and mechanism adjustments as summarized under INSPECTION AND TEST. The necessary readjustments should be made as described under ADJUSTMENTS.
  5. The breaker and operating mechanism should be carefully inspected for loose nuts, bolts, damaged parts, etc.; all cam latch and roller surfaces should be inspected for damage or excessive wear.
  6. Lubricate the breaker operating mechanism in accordance with the table under LUBRICATION.
  7. Inspect all wiring for tightness of connections and possible damage to insulation.
  8. After the breaker has been serviced, it should be slowly closed and opened, as described in INSTALLATION, to be sure there is no binding or friction and that the movable contact on the interrupter can move to the fully opened and fully closed positions. Its electrical operation should then be checked using either the test cabinet or the test couplers.
- B. Every 10,000 operations or Approximately Every Five Years, whichever comes first the following should be accomplished:
  1. At this time the breaker should be given a general overhaul and all excessively

worn parts in both the mechanism and breaker replaced. Such wear will usually be indicated when the breaker cannot be adjusted to instruction book tolerances. This overhaul and inspection is more detailed and will require disassembly of mechanism and breaker operating parts.

2. All roller and needle bearings in the operating mechanism should be disassembled, cleaned, and repacked with G-E lubricant D50H15 as described under LUBRICATION.
3. The breaker and operating mechanism should be serviced as described for every 2,000 operations and properly adjusted before being put back into service.

## RECOMMENDED MAINTENANCE OF BREAKERS APPLIED TO REPETITIVE SWITCHING DUTY

Vacuum breakers applied to repetitive operation such as switching arc furnaces and motors should be serviced and maintained according to the following schedule:

- A. Every 2000 operations, or every six months, whichever comes first:
  1. Maintain breakers per item "A" of Normal Switching Duty Above.
- B. Every 20,000 operations, or every five years, whichever comes first:
  1. Maintain breakers per Item "B" of Normal Switching Duty Above.

## REPAIR AND REPLACEMENT

The following information covers in detail the proper method of removing various parts of the breaker in order to make any necessary repairs. This section includes only those repairs that can be made at the installation on parts of the breaker that are most subject to damage or wear.

**IMPORTANT: UPON COMPLETION OF ANY REPAIR WORK, ALL BREAKER AND MECHANISM ADJUSTMENTS MUST BE CHECKED.**

Refer to the section on INSTALLATION, paying particular attention to ADJUSTMENTS.

The listed terms "Right" and "Left" apply when facing the panel end of the breaker.

### Primary Disconnect Fingers

Refer to Fig. 25. To remove the primary disconnect fingers remove bolt and retainer (3). Slide the front spring (2) to the rear into the contact groove of the finger. The finger cage can now be pulled to the rear.

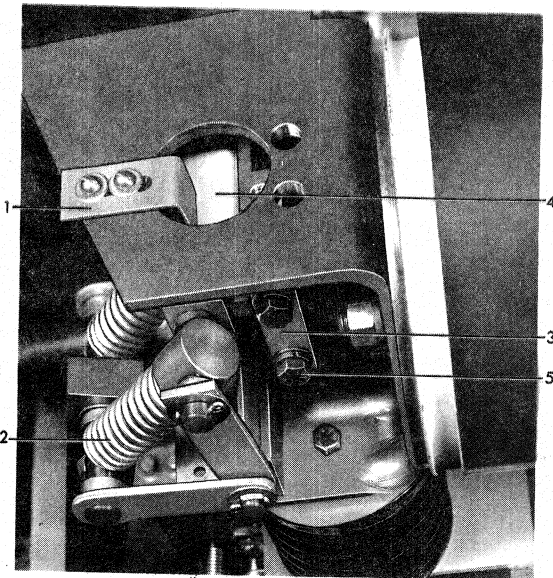


Figure 21 (8039381) Wipe Cage

1. Indicator Pointer
2. Primary Contact Springs
3. Braid Connection Block
4. Indicator
5. Bolts

When the cage has been replaced the spring must be returned to its proper place on the finger. This can be accomplished by carefully working the spring into its normal position with a screwdriver and holding in place with your hand. Be careful not to scratch or mar the silver contact surface of the stud.

#### Interrupters

SEE APPENDIX B

Page 27

#### Primary Contact Studs

If it becomes necessary to remove the stationary contact studs, they should be removed one at a time. This will allow measurements to be made to adjacent studs for proper realignment.

To remove left hand stud (5) Fig. 27 remove two bolts (6). The right hand stud (12) Fig. 5 is held to the insulator with two bolts (15), and to the interrupter support (7) with two bolts (16).

#### Interlock Switch

To remove the two interlock switches (2) Fig. 8, remove the two mounting screws and disconnect the wires. Reassemble in the reverse order and check the switch adjustment as explained under ADJUSTMENTS.

#### Closing Latch Monitoring Switch

To remove the closing latch switch (1) Fig. 13 remove the bolts and disconnect the wires. Reassemble in the reverse order and check the switch adjustments as explained above.

#### Tripping Latch Checking Switch

To remove the tripping latch switch (1) Fig. 23 remove the mounting screws and disconnect the wires. Reassemble in the reverse order and check the switch adjustment as explained under ADJUSTMENTS.

#### Motor, Relay and Light Switches

To remove these switches (1) Fig. 16, move the mounting screws and disconnect the wires. Reassemble in the reverse order and check the switch adjustments as explained under ADJUSTMENTS.

#### Spring Release and Trip Coils

The spring release coil (1) Fig. 17 and the trip coil (2) can be replaced as follows:

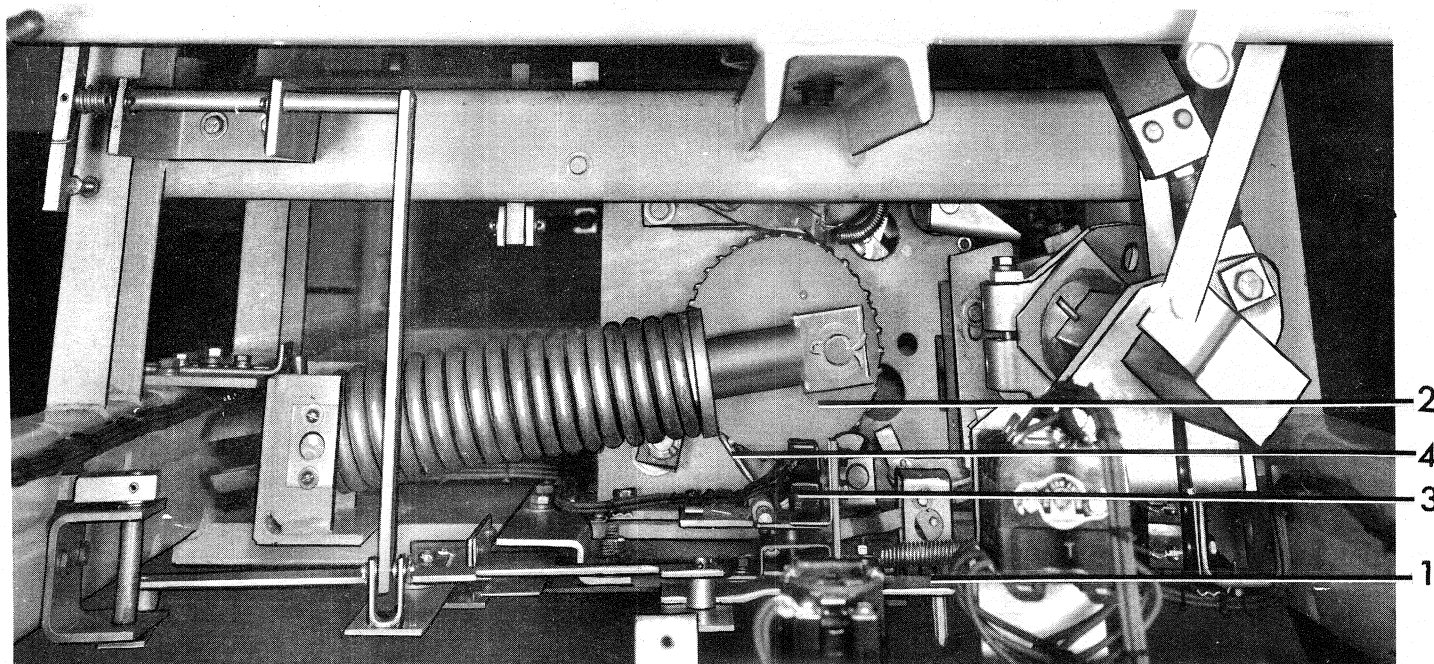


Figure 22. (8039373) Top Plate and Racking Screw Removed

- |                          |                         |
|--------------------------|-------------------------|
| 1. Racking Screw Shutter | 3. Motor Switch         |
| 2. Ratchet Wheel         | 4. Motor Switch Striker |

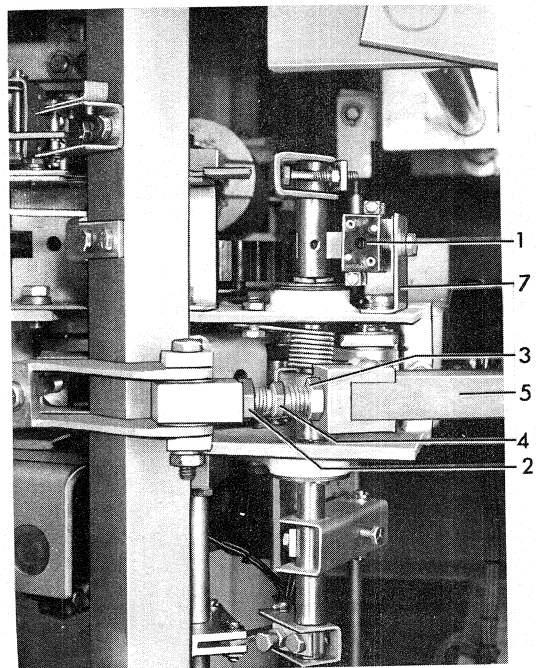


Figure 23 (8039377) Operating Rod

1. Trip Latch Checking Switch
2. Nut
3. Nut
4. Adjustment Screw
5. Operating Rod
7. Switch Support

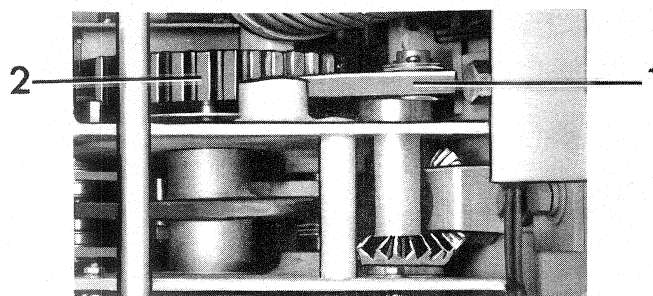


Figure 24 (8039319) Manual Close Mechanism

1. Manual Driving Pawl
2. Ratchet Wheel

1. Cut the wires close to the coil.
2. Remove stop bolt (4) and nut.
3. Remove two Coil Support Mounting Bolts.
4. When replacing the coil be sure to assemble the correct fiber spacers at the end before bolting supports in place.
5. Adjust stop bolt (4) and nut to allow approximately 1/8" of freedom for link.
6. Be certain armature is centered in the coil and is not binding.
7. Butt connect wires and check operation of solenoid electrically and mechanically.

### RENEWAL PARTS

It is recommended that sufficient renewal parts be carried in stock to enable the prompt replacement of any worn, broken, or damaged parts. A stock of such parts minimizes service interruptions caused by breakdowns, and saves time and expense. When continuous operation is a primary consideration, more renewal parts should be carried, the amount depending upon the severity of the service and the time required to secure replacements.

Renewal parts which are furnished may not be identical to the original parts, since improvements are made from time to time. The parts which are furnished, however, will be interchangeable.

The Renewal Parts List Table II covers the following types of breakers:

VH-13.8-500-OK	1200A and 2000A
VH-13.8-500-OKB	1200A and 2000A
VH-13.8-500-OKR	1200A and 2000A
VH-13.8-500-OKBR	1200A and 2000A

NOTE: The listed terms "Right" and "Left" apply when facing the panel end of the breaker.

### ORDERING INSTRUCTIONS

1. Always specify the complete nameplate data of both the breaker and the mechanism.
2. Specify the quantity, catalog number (if listed), reference number (if listed), and description of each part ordered, and this bulletin number.
3. Standard hardware, such as screws, bolts, nuts, washers, etc. is not listed in this bulletin. Such items should be purchased locally.
4. For prices, refer to the nearest office of the General Electric Company.

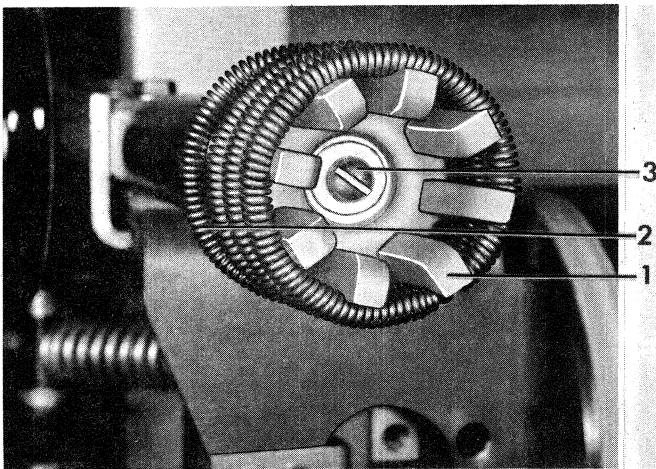


Fig. 25 (8039374) Primary Disconnect Fingers

1. Fingers
2. Front Spring
3. Bolt and Retainer

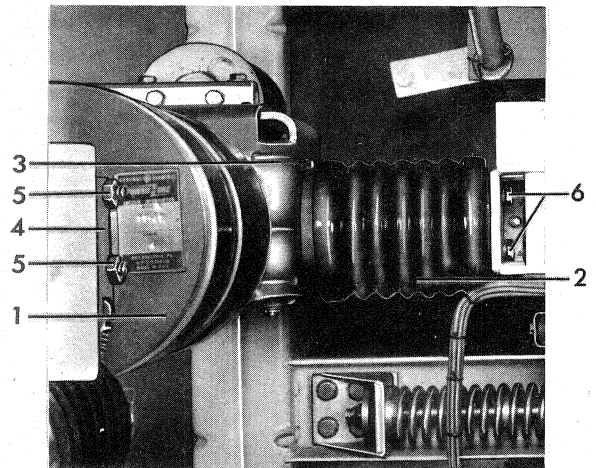


Fig. 26 (8039379) Interrupter Support

1. Interrupter
2. Insulator
3. Support
4. Braid Connection Block
5. Bolts
6. Bolts to the Frame

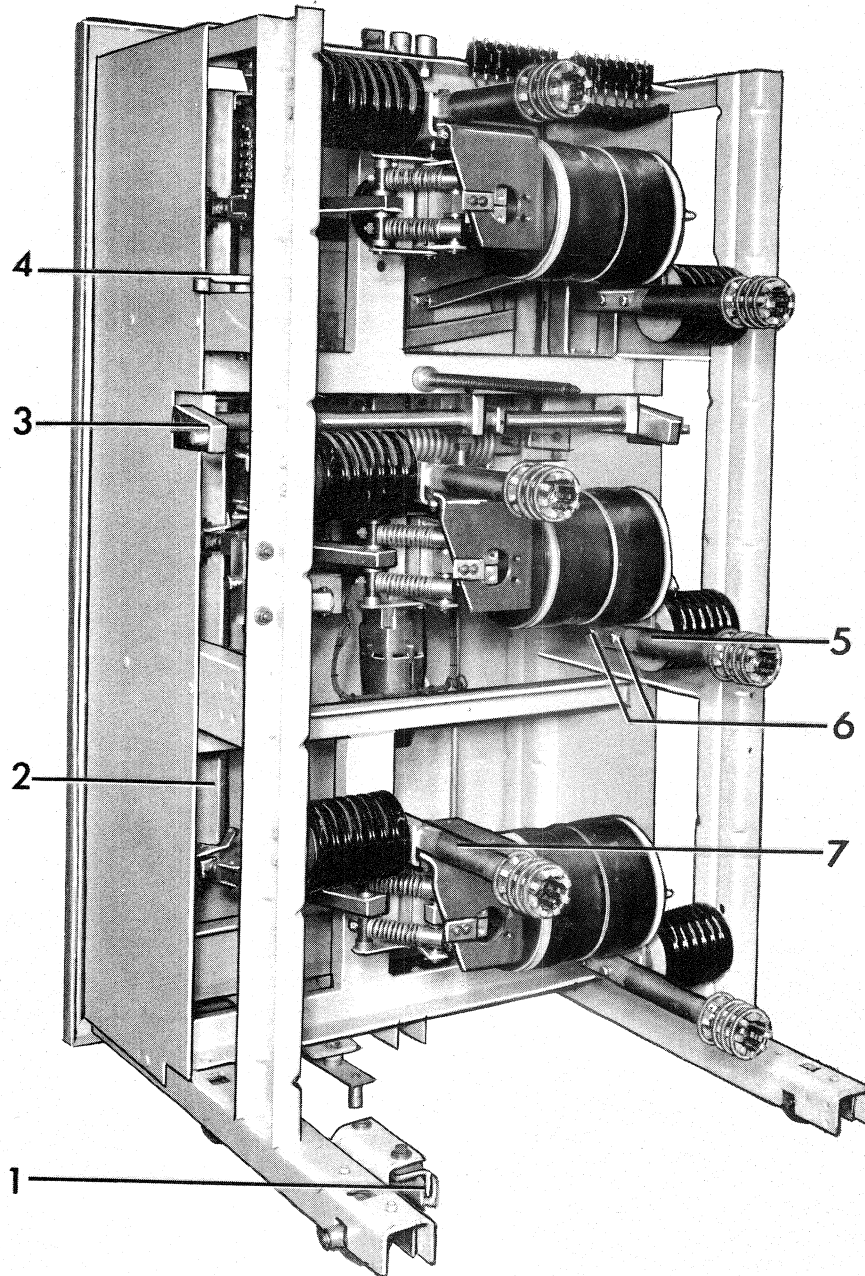


Figure 27. (8039299) Rear View of Breaker

1. Ground Shoe
2. Square Shaft
3. Position Stop
4. Positive Interlock Roller
5. Left Hand Stud
6. Two Stud Holding Bolts
7. Right Hand Stud

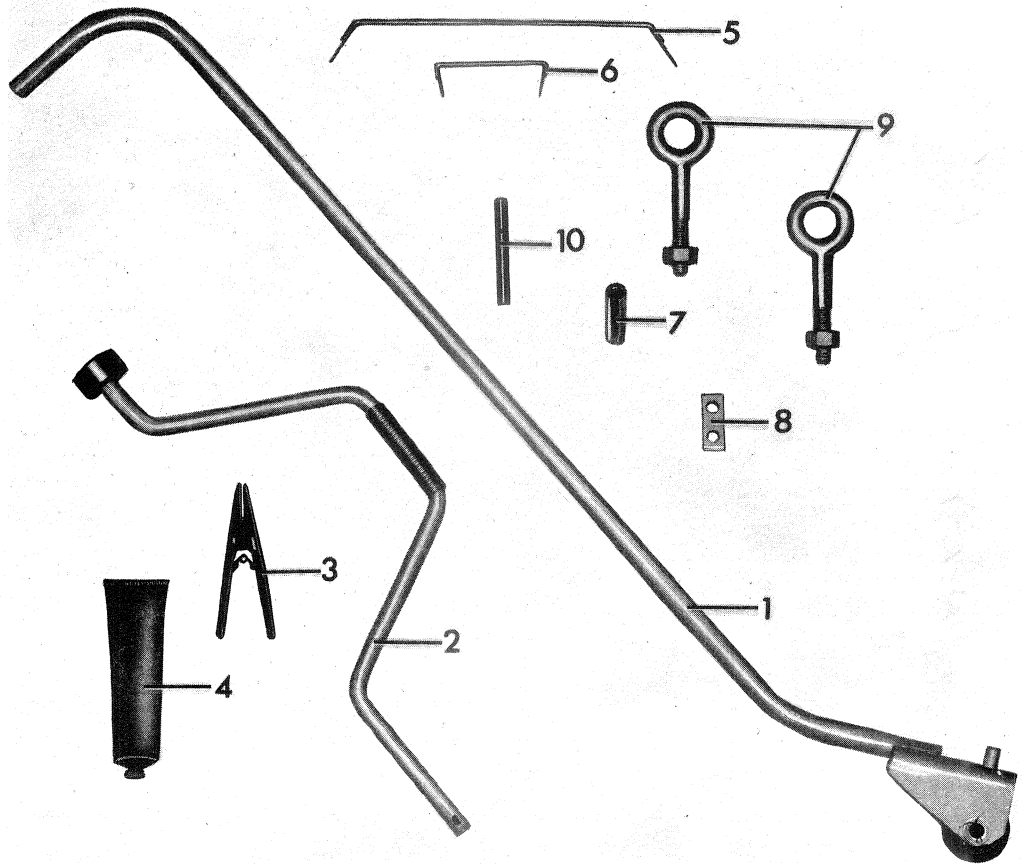


Figure 28. (8039446) Maintenance Kit

1. Transport Handle
2. Hand Crank
3. Retaining Ring Pliers
4. D50H15 Grease
5. Latch Gage
6. Latch Gage
7. Tube Blocking Spacer
8. Tube Blocking Spacer
9. Lifting Eyes
10. Spring Blocking Pin

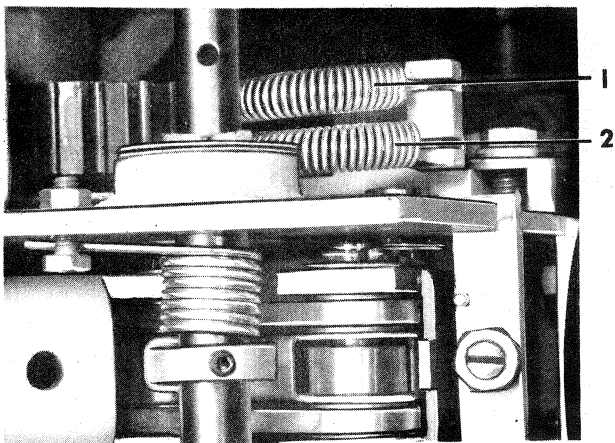
TABLE I

PART	LUBRICATION AT MAINTENANCE PERIOD	ALTERNATE LUBRICATION (REQUIRES DIS-ASSEMBLY)
Sleeve Bearings - links, etc. (Teflon coated bearings)	No Lubrication required	No lubrication required
Sleeve Bearings - main crank shaft, Operating rod, opening spring connections, pawls, etc. (Bronze)	Light application of machine oil SAE 20 or SAE 30.	Remove bearings or links clean per instructions and apply D50H15 lubricant liberally
Roller and Needle Bearings	Light application of machine oil SAE 20 or SAE 30.	Clean per instructions and repack with D50H15 lubricant
Ground surfaces such as cams, ratchet teeth, etc. (Surfaces coated with MoS <sub>2</sub> )	No lubrication required	No lubrication required
Ground surfaces such as latches, rollers, etc.	Wipe clean and apply D50H15 lubricant	Wipe clean and apply D50H15 lubricant
Silver Plated primary disconnect studs	Wipe clean and apply D50H47	Wipe clean and apply D50H47
Dashpot	Check oil level-add dashpot grade oil D50H27 if necessary	Check oil level-add dashpot grade oil D50H27 if necessary

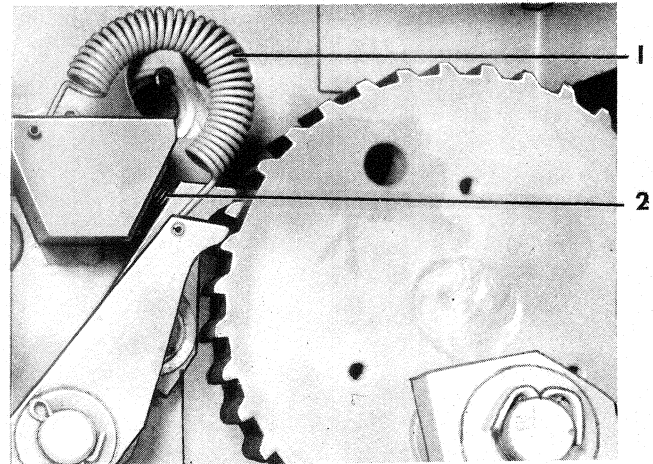


TABLE II

AMPERE RATING	CATALOG NO.	NO. REQ'D.	DESCRIPTION.
1200	195A4099 G-1	3	Power Vac Interrupter Asm. 40 kA
2000	195A4099 G-2	3	Power Vac Interrupter Asm. 40 kA
1200	195A4099 G-3	3	Power Vac Interrupter Asm. 60 kA
2000	195A4099 G-4	3	Power Vac Interrupter Asm. 60 kA
All	121C3444 G-1	3	Operating Rod
All	121C3439 G-2	3	Insulator - Center
All	121C3439 G-1	6	Insulator - L.H. & R. H.
1200	195A4091 G-1	6	Primary Disconnect Finger Asm.
2000	195A4091 G-3	6	Primary Disconnect Finger Asm.
All	*	*	Driving Pawl Spring
All	208A9458 P-1	1	Latching Pawl Spring
All	121C8188 G-1	1	Motor 48 Vdc
All	121C8188 G-2	1	Motor 115 Vac - 125 Vdc
All	121C8188 G-3	1	Motor 230 Vac - 250 Vdc
All	137A7575 P-4	1	Relay 48 Vdc
All	137A7575 P-1	1	Relay 125 Vdc
All	208A9400 G-1	1	Relay 250 Vdc
All	137A7575 P-5	1	Relay 115 Vac
All	137A7575 P-2	1	Relay 230 Vac
All	6174582 G-12	1	Potential Trip Coils 24 Vdc
All	6174582 G-34	1	Potential Trip Coil 48 Vdc
All	6174582 G-40	1	Potential Trip Coil 110-125 Vdc
All	6174582 G-41	1	Potential Trip Coil 220-250 Vdc
All	6174582 G-10	1	Potential Trip Coil 115 Vac
All	6174582 G-14	1	Potential Trip Coil 230 Vac
All	6174582 G-34	1	Spring Release Coil 48 Vdc
All	6174582 G-40	1	Spring Release Coil 110-125 Vdc
All	6174582 G-10	1	Spring Release Coil 115 Vac
All	6174582 G-41	1	Spring Release Coil 220-250 Vdc
All	6174582 G-14	1	Spring Release Coil 230 Vac
All	456A866 P-5	5	Switches Normally open
All	456A866 P-6	1	Switch Normally Closed
All	137A9192 G-11	1	Auxiliary Switch



A (8039318)



B (8041559)

Figure 29. Pawl Arrangement

1. Driving Pawl Spring

2. Holding Pawl Spring

\* Two different Pawl Spring Arrangements exist. If arrangement is as shown in Figure 29A, the Driving Pawl Spring (Ref. 1) and Holding Pawl Spring (Ref. 2) are the same. Order Cat. 0195A4000P4 2 required per mechanism. If arrangement is as shown in Figure 29B, order: Driving Pawl Spring (Ref. 1) Cat. 0195A4000P4 - 1 required. Holding Pawl Spring (Ref. 2) Cat. 0208A9458P1 - 1 required.

APPENDIX A

DASHPOT

The oil filled dashpot (1) Fig. 19 (GEI-88772) protects the bellows of the interrupter movable contact by limiting the overtravel and rebound of the contacts during an opening operation.

The stroke of the piston rod is adjusted at the factory to be  $7/16 + 1/32$ " and it should be checked during maintenance inspection of the breaker. The following procedure is suggested for checking and adjusting the piston stroke. See sketch A19 of this supplement.

1. Remove the right side sheet of the breaker and with the breaker open measure from the lower edge of the mechanism front support plate to the top of the piston rod.
2. Then close the breaker and remeasure from the same reference point to the top of the piston rod. The difference in dimensions between steps 1 and 2 is the piston stroke and should be  $7/16" + 1/32$ ,
3. To readjust the piston stroke: with the breaker still in the closed position loosen the adjusting screw lock nut. Turn the adjusting screw out away from piston rod to increase the stroke and in toward the piston rod to decrease the stroke. After readjustment the adjusting screw should be securely locked and the breaker reoperated to check the adjustment.

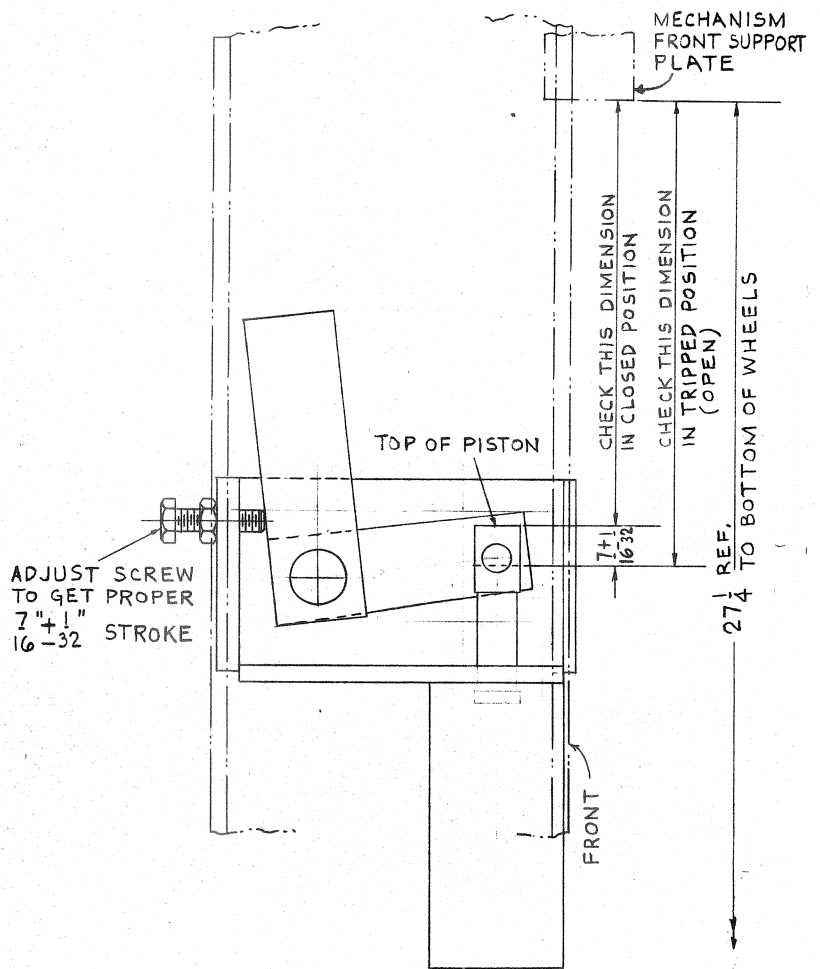


Figure A19 (227A5392)

The oil level of the dashpot should also be checked during maintenance inspection of the breaker, or if there is any indication of oil leakage. Remove pipe plug (6) Figure 19 and add dashpot oil, GE Spec. D50H27 ("UNIVIS" J43 or equivalent) if needed, up to lower level of plug hole. Do not overfill. A suitable thread sealer, such as plumber's pipe thread tape, should be applied to the plug before it is replaced.

APPENDIX BINTERRUPTERS

To mate a new interrupter assembly to the operating mechanism without overtravel of the interrupter movable contacts and possible damage to its bellows the following procedure should be followed. All figure references refer to GEI 88772.

Refer to Figure 26. The interrupter assembly being replaced should be removed as a unit (See Step 1). This includes the interrupter (1), support (3), and the operating rod (6), Figure 12. It is not necessary to remove or loosen any of the primary studs (11) and (12), Figure 5. These have been accurately aligned at the factory to assure proper contacting with the metal clad primary contacts.

- 1- Before removing the interrupter assembly being replaced block the closing springs as described under Installation on Page 3, Item 2, and slow close the breaker until the contact wear indicator pointer (1), Figure 21 lines up with the front edge of the 1/8" wide wear line (indicator completely covers width of line). The interrupter contacts are now in the normal "just touching" position, but are not wiped fully closed. With the mechanism in this position measure and record the dimension from the nearest face of the square shaft (8) to the center line of the operating rod bolt (4), Figure 12.
- 2- With the closing springs still blocked and without moving the operating mechanism disassemble the interrupter assembly as follows.
  - a) Remove operating rod bolt (4), Figure 12.
  - b) Disassemble bolts (10), Figure 5 and disengage braid connection block (9), Figure 5 from stationary contact of interrupter.
  - c) Remove vertical bolts (16), Figure 5 holding the wipe cage (7) to the right hand primary stud (12), Figure 5.
  - d) Remove two bolts holding wipe cage (7) to insulator (13), Figure 5.

NOTE - THE ASSEMBLY SHOULD BE PROPERLY SUPPORTED BEFORE REMOVING THESE LAST TWO BOLTS.
- 3- The interrupter assembly can now be removed by raising its left end about 2" and moving the assembly to the left until it can be removed from the breaker frame.
- 4- With the closing springs still blocked and without moving the operating mechanism reassemble the new interrupter assembly in reverse order. Care must be taken not to twist or stretch the movable contact bellows during this reassembly. Before replacing operating rod bolt (4), Figure 12 adjust length of new operating rod by means of

adjustment screw (2), Figure 12 so dimension from face of square shaft to center line of bolt is same as was measured in Step 1. The interrupter contacts, which were in the closed position when shipped are to remain closed when the operating rod length is adjusted and the bolt is reassembled. The new interrupter assembly will now have approximately the same adjustment as the original assembly.

- 5- The primary contact gap should now be checked as follows:
  - a) Measure and record the dimension from the inside surface of the wipe cage to the edge of the braid connection block.
  - b) With the closing springs still blocked manually trip the breaker open, being sure it opens fully. Remeasure the dimension between the wipe cage and the braid connection block. The difference between this dimension and the measurement in 5a is the contact gap. It should be  $3/4" +0, - 1/32"$  and can, if necessary, be adjusted as described on Page 10, "Primary Contact Gap".
- 6- Charge and unblock the closing springs. Close the breaker by pushing the Manual Close button and check the primary contact wipe. It should be  $5/16" +0, - 1/32"$  and can, if necessary be adjusted as described on Page 10, "Primary Contact Wipe".
- 7- The contact wear indicator (1), Figure 21 can now be set as described on Page 14, "The Breaker Element", Item 1. After locking the indicator in place mark its position, for future reference, by scribing a line across the indicator onto the wipe cage.
- 8- The new interrupter is now assembled and properly adjusted. Before returning the breaker to service it should be given a high potential test as described on Page 14, "Hipot Testing of Vacuum Interrupter".